



Chipsmall Limited consists of a professional team with an average of over 10 year of expertise in the distribution of electronic components. Based in Hongkong, we have already established firm and mutual-benefit business relationships with customers from,Europe,America and south Asia,supplying obsolete and hard-to-find components to meet their specific needs.

With the principle of “Quality Parts,Customers Priority,Honest Operation,and Considerate Service”,our business mainly focus on the distribution of electronic components. Line cards we deal with include Microchip,ALPS,ROHM,Xilinx,Pulse,ON,Everlight and Freescale. Main products comprise IC,Modules,Potentiometer,IC Socket,Relay,Connector.Our parts cover such applications as commercial,industrial, and automotives areas.

We are looking forward to setting up business relationship with you and hope to provide you with the best service and solution. Let us make a better world for our industry!



Contact us

Tel: +86-755-8981 8866 Fax: +86-755-8427 6832

Email & Skype: info@chipsmall.com Web: www.chipsmall.com

Address: A1208, Overseas Decoration Building, #122 Zhenhua RD., Futian, Shenzhen, China



IPC-7132

Cost-effective Wallmount Chassis for ATX/mATX Motherboard and 10-slot Backplane



Features

- Support ATX/mATX M/B and 10-slot PICMG 1.3 backplane
- Shockproof drive bay for one 5.25" ODD and three 3.5" HDDs
- Thumb-screw for top cover easy opening
- Bidirectional option to mount chassis on wall or workbench
- Two front access USB ports

CE FCC

Specifications

		External	Internal
Disk Drive Bay	3.5"	1	2
	5.25"	1	-
Cooling	Fan	1 (12 cm/85 CFM)	
	Air Filters	Yes	
Front I/O interface	USB 2.0	2	
Miscellaneous	LED Indicators	Power, HDD	
	Control	Power Switch, System Reset Button	
	Rear panel	4x USB, 2x DB-9, 1x LPT port	
Environment	Temperature	Operating 0 ~ 40° C (32 ~ 104° F)	Non-operating -20 ~ 60° C (-4 ~ 140° F)
	Humidity	10 ~ 85 % @ 40° C, non-condensing	
	Vibration (5-500 Hz)	1 Grms	
	Shock	10 G (with 11 ms duration, half sine wave)	
	Dimensions (W x H x D)	200 x 330 x 430 mm (7.9" x 13" x 16.9")	
Physical Characteristics	Weight	9.96 kg (21.93 lb)	

Front View

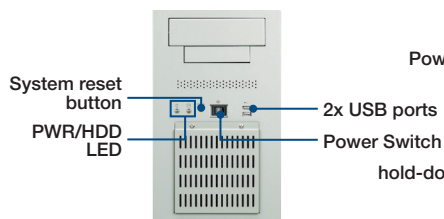

Inside View

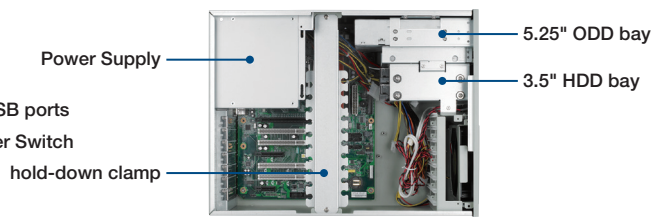

IPC-7132MB

Rear View

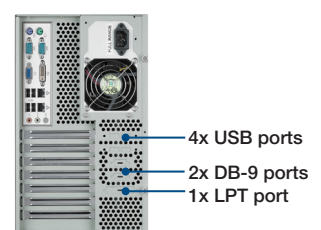

IPC-7132MB



Easy-to-maintain cooling fan



IPC-7132BP

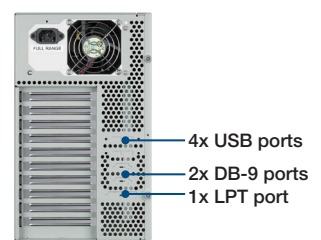

IPC-7132BP

Dimensions

Unit: mm [inch]

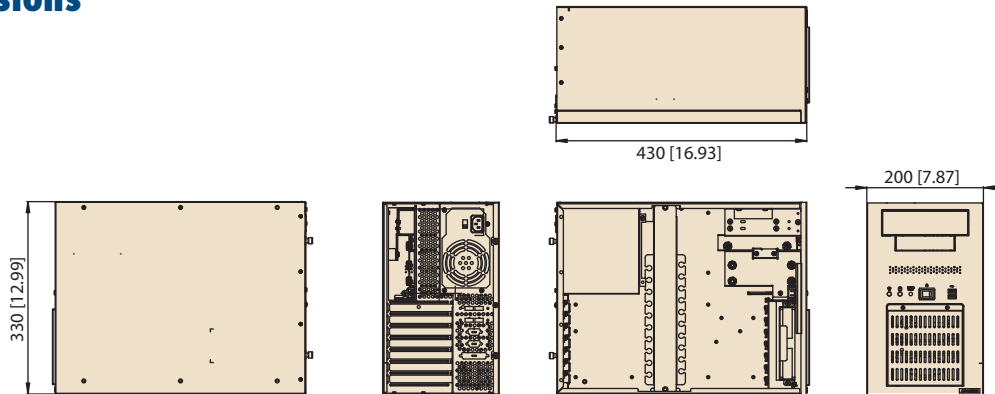

Installation

Unit: mm [inch]

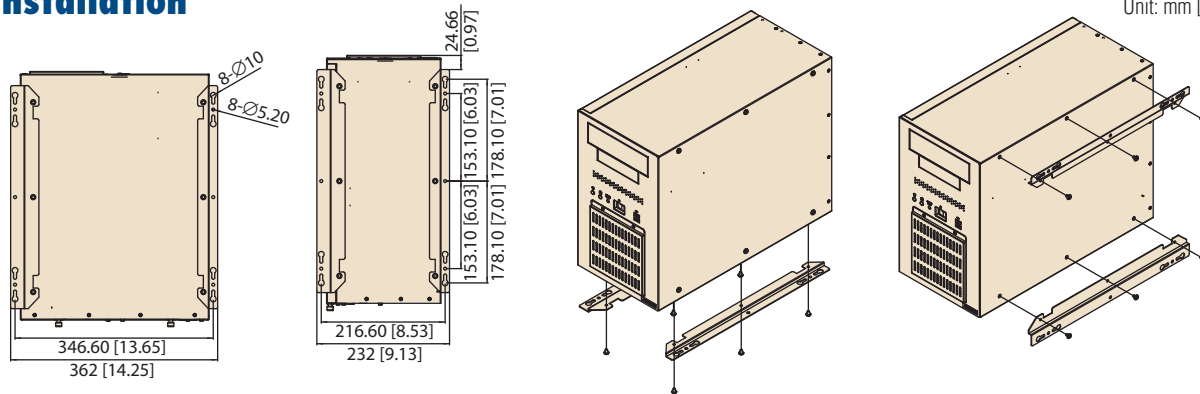

Ordering Information

Model Name	Power supply	Wattage	Switch Type
Motherboard Version			
IPC-7132MB-00XE	-	-	ATX
IPC-7132MB-25ZE	96PS-A250WPS2	250W	ATX
IPC-7132MB-30ZE	96PS-A300WPS2	300W	ATX
IPC-7132MB-40ZE	96PS-A400WPS2	400W	ATX
Backplane Version			
IPC-7132BP-00XE	-	-	ATX

Optional Accessories

Part Number	Description
IPC-DT-3120E	Mobile HDD tray for dual 2.5" SATA HDDs
1750006427	87.87 CFM, system fan 120 x 120 x 25.0 mm

Backplane Options

Model	PICMG 1.3	PCIe	PCI-X	PCI
PCE-5B09-06A1E	PICMG 1.3	1 (PCIe x4)	-	6
PCE-5B09-04A1E	PICMG 1.3	3 (PCIe x4)	-	4