



Chipsmall Limited consists of a professional team with an average of over 10 year of expertise in the distribution of electronic components. Based in Hongkong, we have already established firm and mutual-benefit business relationships with customers from,Europe,America and south Asia,supplying obsolete and hard-to-find components to meet their specific needs.

With the principle of “Quality Parts,Customers Priority,Honest Operation,and Considerate Service”,our business mainly focus on the distribution of electronic components. Line cards we deal with include Microchip,ALPS,ROHM,Xilinx,Pulse,ON,Everlight and Freescale. Main products comprise IC,Modules,Potentiometer,IC Socket,Relay,Connector.Our parts cover such applications as commercial,industrial, and automotives areas.

We are looking forward to setting up business relationship with you and hope to provide you with the best service and solution. Let us make a better world for our industry!



Contact us

Tel: +86-755-8981 8866 Fax: +86-755-8427 6832

Email & Skype: info@chipsmall.com Web: www.chipsmall.com

Address: A1208, Overseas Decoration Building, #122 Zhenhua RD., Futian, Shenzhen, China



DO NOT SCALE FROM THIS PRINT

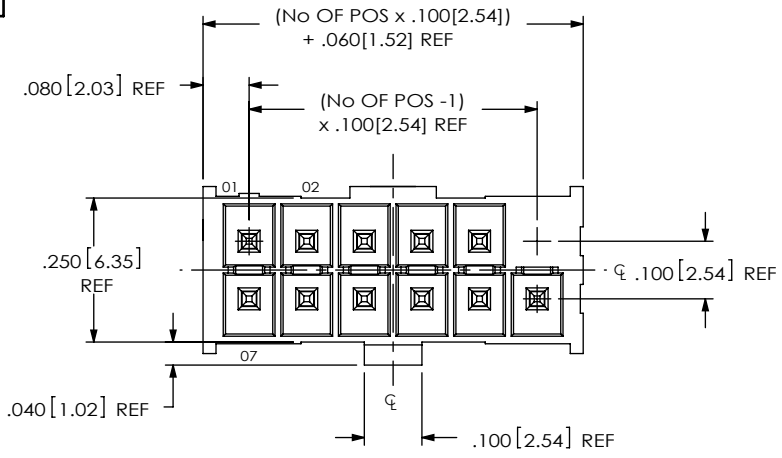
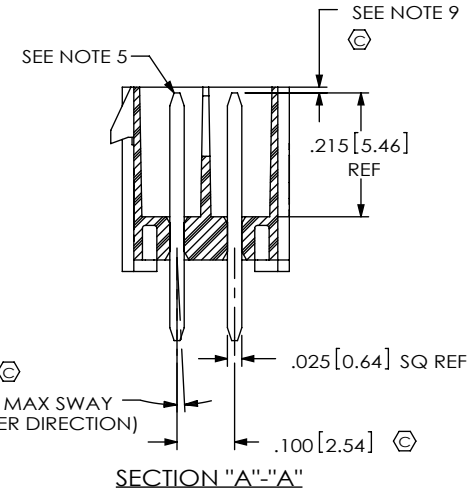
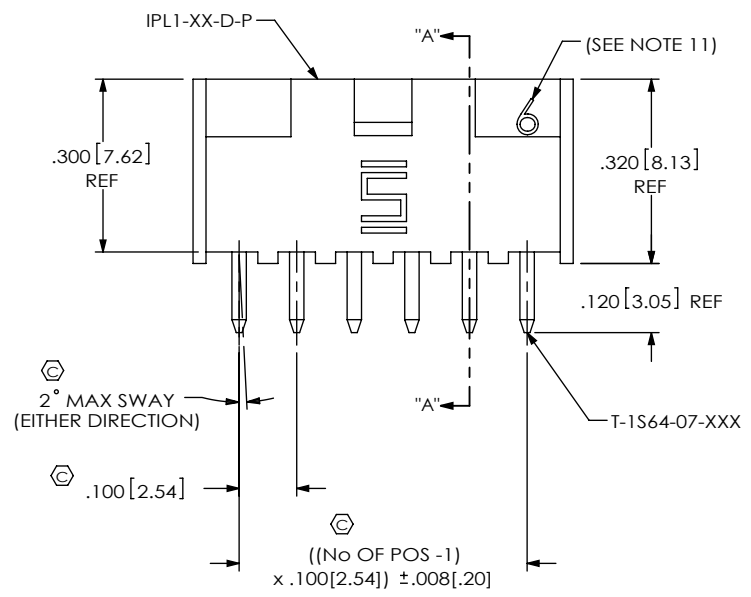

FIG 1
IPL1-106-01-XXX-D-P SHOWN

IPL1-1XX-XX-XXX-D-XX-X-XX

- No OF POSITIONS**
-02 THRU -25 (PER ROW)
- LEAD STYLE**
-01: THROUGH HOLE (USE T-1S64-XX-XX)
-02: SURFACE MOUNT (SEE FIG 2, SHT 2) (USE T-1S64-XX-XX)
- PACKAGING OPTION**
-TR: TAPE & REEL (AVAILABLE WITH -02 LEAD STYLE ONLY) (MUST USE K-DOT-.256-.375-.005) (SEE FIG 8, SHT 3)
- OPTION**
-P: POLARIZATION (SEE FIG 1) (USE IPL1-XX-D-P) (NOT AVAILABLE W/ -K OR -G, OPTIONS)
-K: KEYED POLARIZATION (USE IPL1-XX-D-K) (SEE FIG 5, SHEET 3) (NOT AVAILABLE W/ -P OR -G, OPTIONS)
-G: GUIDE POSTS (SEE FIG 6 & 7, SHEET 3) (USE IPL1-XX-D-GP) (NOT AVAILABLE W/ -P, -K OPTIONS) (LEAVE BLANK FOR NO POLARIZATION (SEE FIG 4, SHEET 3). SAMTEC WILL ONLY SUPPORT EXISTING BUSINESS AS OF REV U)
- OPTION**
-RA: RIGHT ANGLE (SEE FIG 3, SHT 2) (AVAILABLE WITH -01 LEAD STYLE ONLY)
- ROW SPECIFICATION**
-D: DOUBLE (USE IPL1-XX-D)
- PLATING SPECIFICATION**
-F: FLASH SELECTIVE (USE T-1S64-XX-F)
-L: LIGHT SELECTIVE (USE T-1S64-XX-L)
-S: SELECTIVE (USE T-1S64-XX-S)
-H: HEAVY GOLD (T-1S64-XX-H)
-FM: FLASH SELECTIVE/MATTE TIN TAILS (USE T-1S64-XX-F)
-LM: LIGHT SELECTIVE/MATTE TIN TAILS (USE T-1S64-XX-L)
-SM: SELECTIVE/MATTE TIN TAILS (USE T-1S64-XX-S)
-STL: SELECTIVE/TIN/LEAD TAILS (USE T-1S64-XX-STL)



- NOTES:
1. Ⓢ REPRESENTS A CRITICAL DIMENSION.
 2. NOTE DELETED.
 3. MINIMUM TERMINAL RETENTION: 1 LB.
 4. PARTS TO BE MOLDED TO POSITION.
 5. POST MUST BE WITHIN .005[.13] OF EACH OTHER.
 6. ALL PIN TO PIN DIMENSIONS TO BE MEASURED FROM TIP TO TIP.
 7. NOTE DELETED.
 8. DIMENSION TO BE MEASURED AT BEND.
 9. TIP TO BE FLUSH TO .015 BELOW TOP OF SHROUD.
 10. BOTH ROWS TO BE SYMMETRIC WITHIN .010[0.25].
 11. THIS NUMBER REPRESENTS THE NUMBER OF POSITIONS PER ROW ONLY AND IS NOT INTENDED TO BE USED IN POSITION NUMBERING.
 12. 1 OR 2 GATE PADS TO BE PRESENT AT VENDOR DISCRETION.

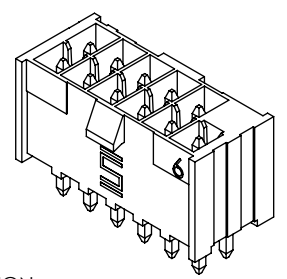

TABLE 1

LEAD STYLE	OPTION	TERMINAL 1	OAL REF	TERMINAL 2	OAL REF	-TR
-01	NONE	T-1S64-07-X	.430[10.92]	N/A	N/A	N/A
-01	-RA	T-1S64-09-X	.530[13.46]	T-1S64-10-X	.730[18.54]	N/A
-02	NONE	T-1S64-08-X	.445[11.30]	N/A	N/A	K-DOT-.256-.375-.005

UNLESS OTHERWISE SPECIFIED, DIMENSIONS ARE IN INCHES. TOLERANCES ARE:
 DECIMALS .XX: ±.01[.3]
 .XXX: ±.005[.13]
 .XXXX: ±.0020[0.051]
 ANGLES ± 2°

PROPRIETARY NOTE
 THIS DOCUMENT CONTAINS INFORMATION CONFIDENTIAL AND PROPRIETARY TO SAMTEC, INC. AND SHALL NOT BE REPRODUCED OR TRANSFERRED TO OTHER DOCUMENTS OR DISCLOSED TO OTHERS OR USED FOR ANY PURPOSE OTHER THAN THAT WHICH IT WAS OBTAINED WITHOUT THE EXPRESSED WRITTEN CONSENT OF SAMTEC, INC.



520 PARK EAST BLVD, NEW ALBANY, IN 47150
 PHONE: 812-944-6733 FAX: 812-948-5047
 e-Mail: info@SAMTEC.com code 55322

MATERIAL: DO NOT SCALE DRAWING SHEET SCALE: 3:1
 INSULATOR: LCP UL94-V0, COLOR: BLACK
 -K INSULATOR: LCP UL94-V0, COLOR: NATURAL
 TERMINAL: PHOS BRONZE

DESCRIPTION:
 .100[2.54] DOUBLE ROW TERMINAL ASSEMBLY

DWG. NO.
IPL1-1XX-XX-XXX-D-XX-X-XX

BY: KEVIN B 03/11/02 SHEET 1 OF 3

FIG 2
IPL1-106-02-XXX-D-P SHOWN
[DIFFERENT AS SHOWN, OTHERWISE SAME AS FIG 1]

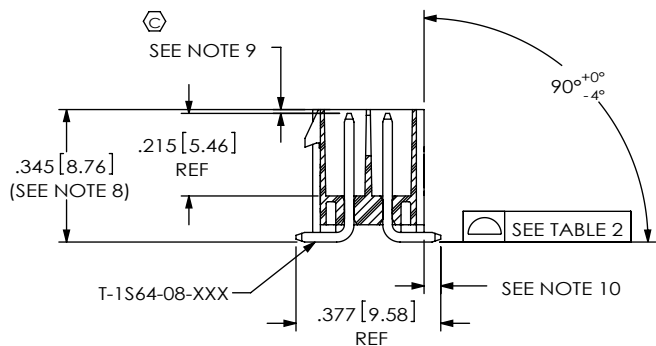
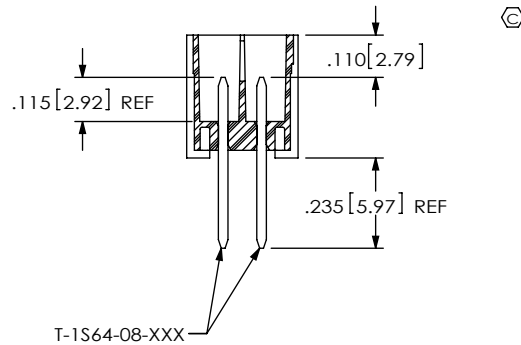
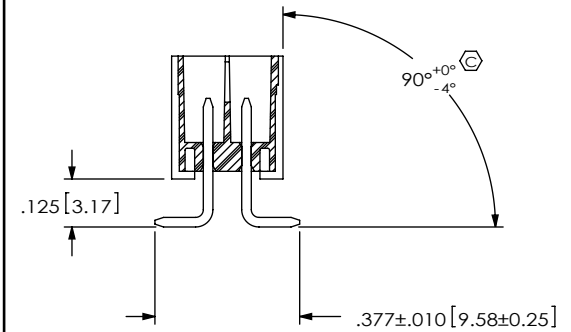

TABLE 2	
No OF POS.	COPLANARITY
-02 THRU -05	.004[.10]
-06 THRU -10	.005[.13]
-11 THRU -25	.006[.15]

-02: SURFACE MOUNT IN PROCESS 1



-02: SURFACE MOUNT IN PROCESS 2



PACKAGING VIEWS
(ASSEMBLIES TO HAVE POSITION #1 LOADED IN THE SAME DIRECTION AS ARROW ON TUBE, EXCEPT WITH -RA OPTION)

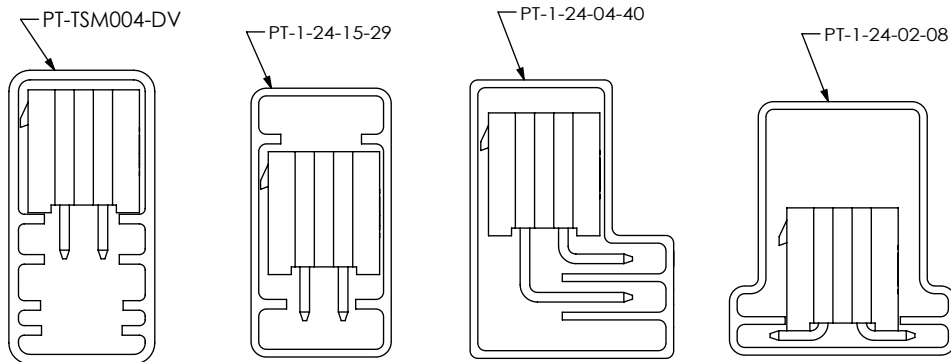

PACKAGING TABLE			
LEAD STYLE	OPTION	PACKAGING TUBE	PLUG
-01	NONE	PT-1-24-15-29	TP-07
-01 (2 POSITION)	NONE	PT-TSM004-DV	TP-07
-01	-RA	PT-1-24-04-40	TP-07
-02	NONE	PT-1-24-02-08	TP-13

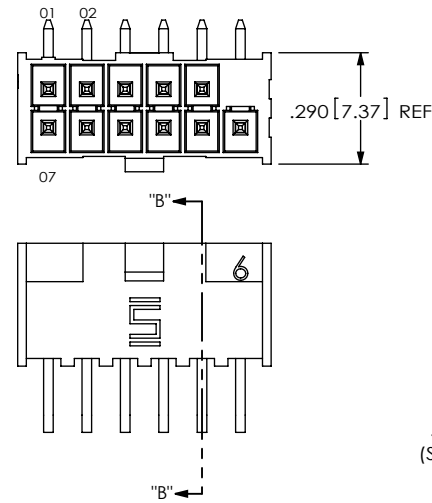
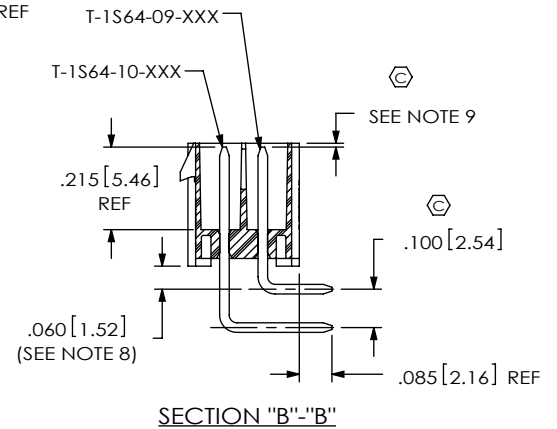

FIG 3
IPL1-106-01-XXX-D-RA-P SHOWN
(DIFFERENT AS SHOWN, OTHERWISE SAME AS FIG 1)



SECTION "B"- "B"

C:\EnterpriseVault\DWG\MISC\MKTG\IPL1-1XX-XX-XXX-D-XX-X-XX-MKT.slddrw

PROPRIETARY NOTE

THIS DOCUMENT CONTAINS INFORMATION CONFIDENTIAL AND PROPRIETARY TO SAMTEC, INC. AND SHALL NOT BE REPRODUCED OR TRANSFERRED TO OTHER DOCUMENTS OR DISCLOSED TO OTHERS OR USED FOR ANY PURPOSE OTHER THAN THAT WHICH IT WAS OBTAINED WITHOUT THE EXPRESSED WRITTEN CONSENT OF SAMTEC, INC.

DO NOT SCALE DRAWING

SHEET SCALE: 2:1



520 PARK EAST BLVD, NEW ALBANY, IN 47150
PHONE: 812-944-6733 FAX: 812-948-5047
e-Mail info@SAMTEC.com code 55322

DESCRIPTION:
.100[2.54] DOUBLE ROW TERMINAL ASSEMBLY

DWG. NO.
IPL1-1XX-XX-XXX-D-XX-X-XX

BY: KEVIN B 03/11/02 SHEET 2 OF 3

REVISION AH

-RA: IN PROCESS 1

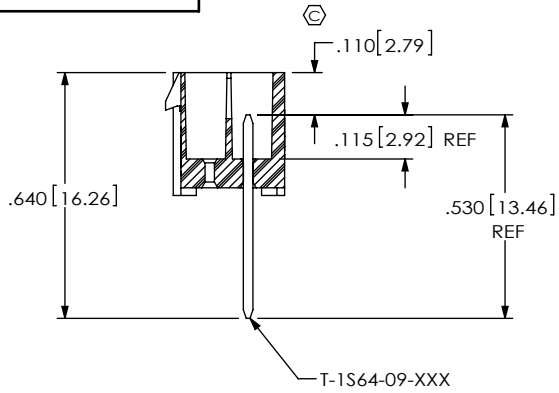

-RA: IN PROCESS 2

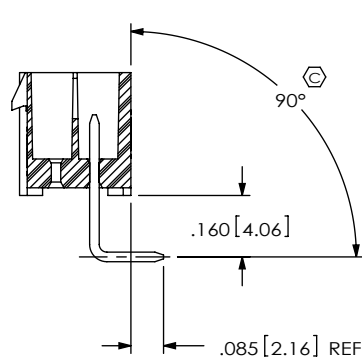

-RA: IN PROCESS 3

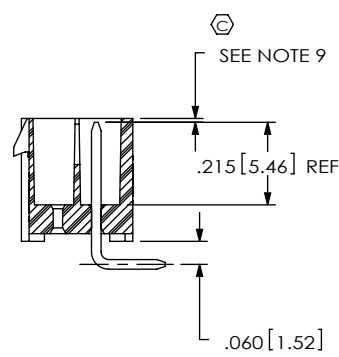

-RA: IN PROCESS 4

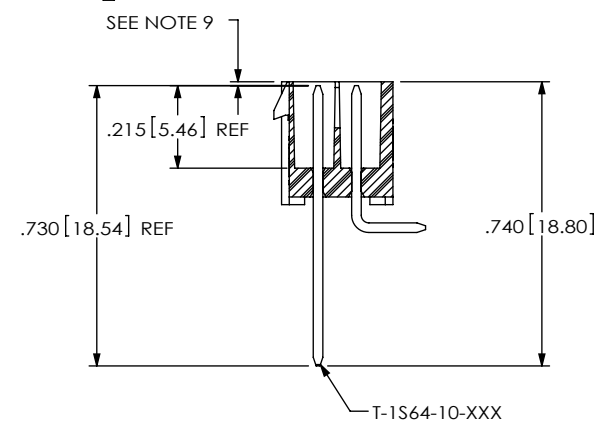

FIG 4
(IPL1-106-01-XXX-D SHOWN)
(DIFFERENT AS SHOWN,
OTHERWISE SAME AS FIG 1)

**SAMTEC WILL ONLY SUPPORT
EXISTING BUSINESS AS OF REV. U)**

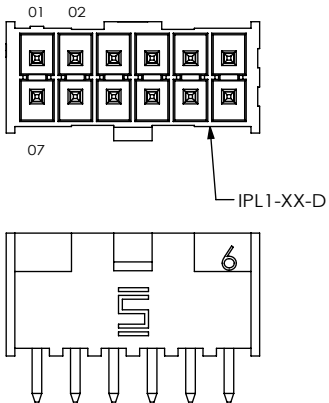

FIG 5
(IPL1-106-01-XXX-D-K SHOWN)
(DIFFERENT AS SHOWN, OTHERWISE SAME AS FIG 4)

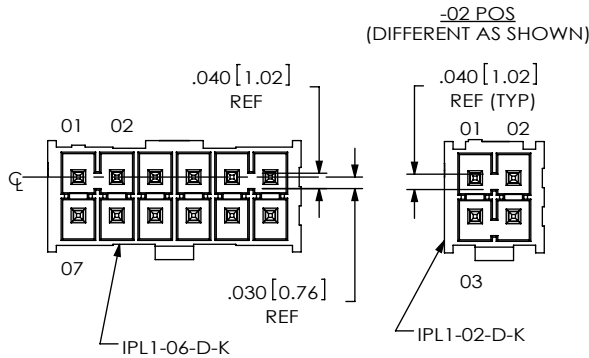

FIG 6
(IPL1-106-01-XXX-D-RA-G SHOWN)
(DIFFERENT AS SHOWN, OTHERWISE SAME AS FIG 3)

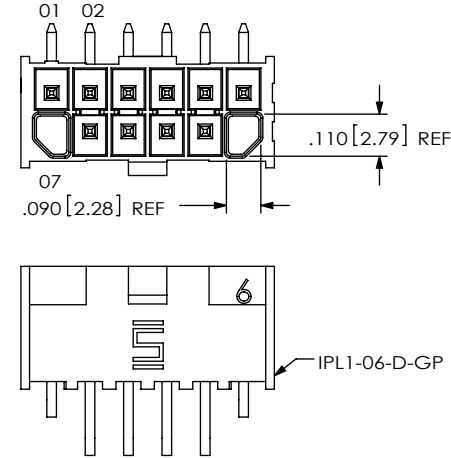

FIG 7
(IPL1-102-01-XXX-D-G SHOWN)
(DIFFERENT AS SHOWN,
OTHERWISE SAME AS FIG 1)

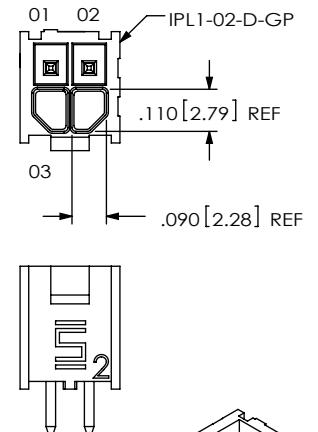
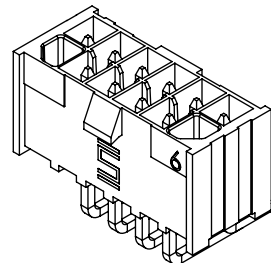
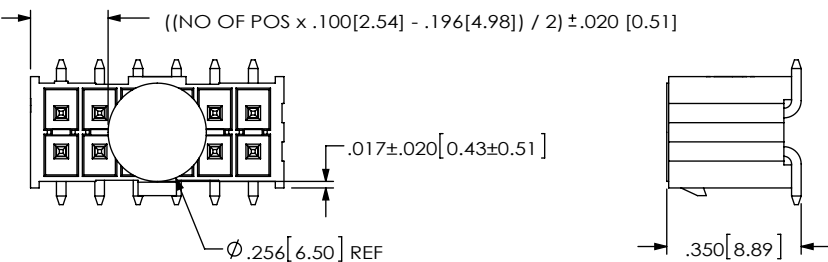

FIG 8
(IPL1-106-02-XXX-D-TR SHOWN)
(MUST USE K-DOT-.256-.375-.005)
(DIFFERENT AS SHOWN, OTHERWISE SAME AS FIG 2)



PROPRIETARY NOTE

THIS DOCUMENT CONTAINS INFORMATION
CONFIDENTIAL AND PROPRIETARY TO
SAMTEC, INC. AND SHALL NOT BE REPRODUCED
OR TRANSFERRED TO OTHER DOCUMENTS OR
DISCLOSED TO OTHERS OR USED FOR ANY
PURPOSE OTHER THAN THAT WHICH IT WAS
OBTAINED WITHOUT THE EXPRESSED WRITTEN
CONSENT OF SAMTEC, INC.

DO NOT SCALE DRAWING

SHEET SCALE: 2:1

samtec

520 PARK EAST BLVD, NEW ALBANY, IN 47150
PHONE: 812-944-6733 FAX: 812-948-5047
e-Mail: info@SAMTEC.com code 55322

DESCRIPTION:
.100 [2.54] DOUBLE ROW TERMINAL ASSEMBLY

DWG. NO.
IPL1-1XX-XX-XXX-D-XX-X-XX

BY: KEVIN B 03/11/02 SHEET 3 OF 3