



Chipsmall Limited consists of a professional team with an average of over 10 year of expertise in the distribution of electronic components. Based in Hongkong, we have already established firm and mutual-benefit business relationships with customers from,Europe,America and south Asia,supplying obsolete and hard-to-find components to meet their specific needs.

With the principle of “Quality Parts,Customers Priority,Honest Operation,and Considerate Service”,our business mainly focus on the distribution of electronic components. Line cards we deal with include Microchip,ALPS,ROHM,Xilinx,Pulse,ON,Everlight and Freescale. Main products comprise IC,Modules,Potentiometer,IC Socket,Relay,Connector.Our parts cover such applications as commercial,industrial, and automotives areas.

We are looking forward to setting up business relationship with you and hope to provide you with the best service and solution. Let us make a better world for our industry!



Contact us

Tel: +86-755-8981 8866 Fax: +86-755-8427 6832

Email & Skype: info@chipsmall.com Web: www.chipsmall.com

Address: A1208, Overseas Decoration Building, #122 Zhenhua RD., Futian, Shenzhen, China



PROTECTED HIGH SIDE SWITCH

Features

- Over temperature shutdown (with auto-restart)
- Short circuit protection (current limit)
- Active clamp
- Open load detection
- Logic ground isolated from power ground
- ESD protection
- Ground loss protection
- Status feedback

Product Summary

Rds(on)	110mΩ max.
Vclamp	70V
I Limit	5A
Open load	3V

Description

The IPS7071GPbF is a fully protected five terminal high side switch with built in short circuit, over-temperature, ESD protection, inductive load capability and diagnostic feedback. The output current is limited at Ilim value. Current limitation is activated until the thermal protection acts. The over-temperature protection turns off the device if the junction temperature exceeds Tshutdown. It will automatically restart after the junction has cooled 7°C below Tshutdown. A diagnostic pin is provided for status feedback of short circuit, over-temperature and open load detection. The double level shifter circuitry allows large offsets between the logic ground and the load.

Package

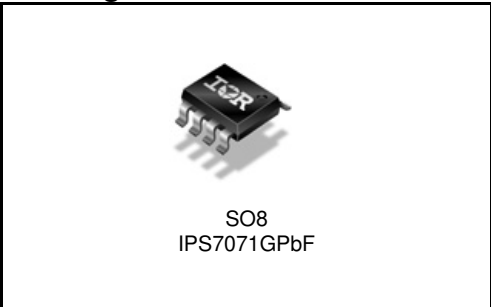

Typical Connection

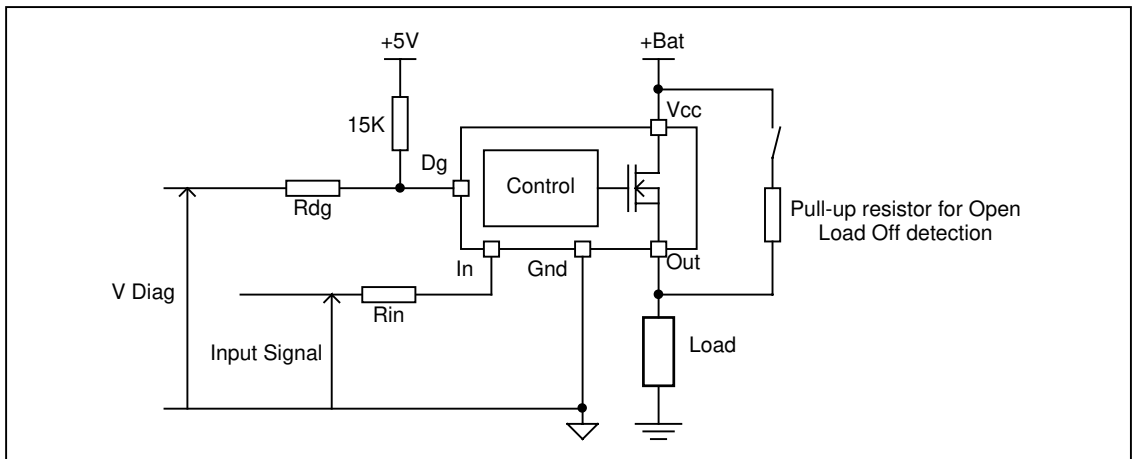

Absolute Maximum Ratings

Absolute maximum ratings indicate sustained limits beyond which damage to the device may occur. All voltage parameters are referenced to Ground lead. (Tambient=25°C unless otherwise specified).

Symbol	Parameter	Min.	Max.	Units
Vout	Maximum output voltage	Vcc-65	Vcc+0.3	V
Voffset	Maximum logic ground to load ground offset	Vcc-65	Vcc+0.3	
Vin	Maximum input voltage	-0.3	5.5	
Vcc max.	Maximum Vcc voltage	—	65	
Vcc cont.	Maximum continuous Vcc voltage	—	35	
Iin max.	Maximum IN current	-1	10	mA
I _{dg} max.	Maximum diagnostic output current	-1	10	
V _{dg}	Maximum diagnostic output voltage	-0.3	5.5	V
P _d	Maximum power dissipation (internally limited by thermal protection) R _{th} =100°C/W	—	1.25	W
I _{sd} cont.	Maximum continuous diode current (R _{th} =100°C/W)	—	1.8	A
ESD1	Electrostatic discharge voltage (Human body) 100pF, 1500Ω	—	4	kV
ESD2	Electrostatic discharge voltage (Machine Model) C=200pF, R=0Ω, L=10μH	—	0.5	
T _j max.	Max. storage & operating temperature junction temperature	-40	+150	°C

Thermal Characteristics

Symbol	Parameter	Typ.	Max.	Units
R _{th1}	Thermal resistance junction to ambient IPS7071G	100	—	°C/W

Recommended Operating Conditions

These values are given for a quick design. For operation outside these conditions, please consult the application notes.

Symbol	Parameter	Min.	Max.	Units
V _{IH}	High level input voltage	4	5.5	
V _{IL}	Low level input voltage	-0.3	0.9	
I _{out}	Continuous drain current, T _{amb} =85°C, T _j =125°C, V _{in} =5V, R _{th} =100°C/W	—	1.5	A
R _{in}	Recommended resistor in series with IN pin	4	10	kΩ
R _{dg_s}	Recommended resistor in series with DG pin	10	20	
R _{ol}	Recommended pull-up resistor for open load detection	5	100	

Static Electrical Characteristics

T_J=25°C, V_{CC}=14V (unless otherwise specified)

Symbol	Parameter	Min.	Typ.	Max.	Units	Test Conditions
Rds(on)	ON state resistance T _J =25°C	—	80	110	mΩ	V _{in} =5V, I _{out} =2.5A
	ON state resistance T _J =150°C (1)	—	130	175		V _{in} =5V, I _{out} =2.5A
	ON state resistance T _J =25°C, V _{CC} =6.5V	—	90	120		V _{in} =5V, I _{out} =2.5A
V _{CC op.}	Operating voltage range	6	—	35	V	
V clamp 1	V _{CC} to Out clamp voltage 1	65	70	—		I _{out} =10mA (see Fig. 1)
V clamp 2	V _{CC} to Out clamp voltage 2 (1)	—	70	75		I _{out} =1A (see Fig. 1)
V _f	Body diode forward voltage	—	1	1.35		I _{out} = 2.5A
I _{CC Off}	Supply current when Off	—	2.5	10	μA	V _{in} =0V, V _{out} =0V
I _{CC On}	Supply current when On	—	2.5	3.5	mA	V _{in} =5V
I _{out@0V}	Output leakage current	—	1.1	10	μA	V _{out} =0V
I _{out@6V}	Output leakage current	—	20	—		V _{out} =6V
I _{dg leakage}	Diagnostic output leakage current	—	—	10		V _{dg} =5.5V
V _{dgl}	Low level diagnostic output voltage	—	0.2	0.3		I _{dg} =1.6mA
V _{ih}	Input high threshold voltage	—	2.5	3.5	V	
V _{il}	Input low threshold voltage	1	2	—		
I _{n hys}	Input hysteresis	0.15	0.4	1		
UV high	Under voltage high threshold voltage	—	5	5.9		
UV low	Under voltage low threshold voltage	3.4	4.5	—		
UV hys	Undervoltage hysteresis	0.1	0.8	1.5		
I _{in On}	Input current when device is On	—	40	80		μA

(1) Guaranteed by design

Switching Electrical Characteristics

V_{CC}=14V, Resistive load=14Ω, V_{in}=5V, T_J=25°C

Symbol	Parameter	Min.	Typ.	Max.	Units	Test Conditions
T _{don}	Turn-on delay time	—	11	35	μs	See Fig. 3
Tr1	Rise time to V _{out} =V _{CC} -5V	—	7	40		
Tr2	Rise time to V _{out} =0.9 x V _{CC}	—	15	50		
dV/dt (On)	Turn On dV/dt	—	1.3	4	V/μs	
E _{On}	Turn On energy	—	75	—	μJ	
T _{doff}	Turn-off delay time	—	23	45	μs	
T _f	Fall time to V _{out} =0.1 x V _{CC}	—	6	25	μs	
dV/dt (Off)	Turn Off dV/dt	—	2	6	V/μs	
E _{Off}	Turn Off energy	—	25	—	μJ	
T _{diag}	V _{out} to V _{diag} propagation delay	—	15	—	μs	See Fig. 4 and Fig. 12

Protection Characteristics

Symbol	Parameter	Min.	Typ.	Max.	Units	Test Conditions
Ilim	Internal current limit (2)	2	5	9	A	Vout=0V
Tsd+	Over temperature high threshold	150(2)	165	—	°C	See Fig. 2
Tsd-	Over temperature low threshold	—	158	—		
Vsc	Short-circuit detection voltage(3)	2	3	4	V	
Vopen load	Open load detection threshold	2	3	4		

(2) Guaranteed by design

(3) Reference to Vcc

Truth Table

Operating Conditions	IN	OUT	DG pin
Normal	H	H	H
Normal	L	L	L
Open Load	H	H	H
Open Load ⁽³⁾	L	H	H
Short circuit to Gnd	H	L (limiting)	L
Short circuit to Gnd	L	L	L
Over-temperature	H	L (cycling)	L
Over-temperature	L	L	L

⁽³⁾ With a pull-up resistor connected between the output and Vcc.

Lead Assignments

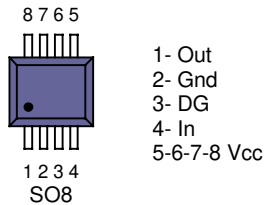

Functional Block Diagram

All values are typical

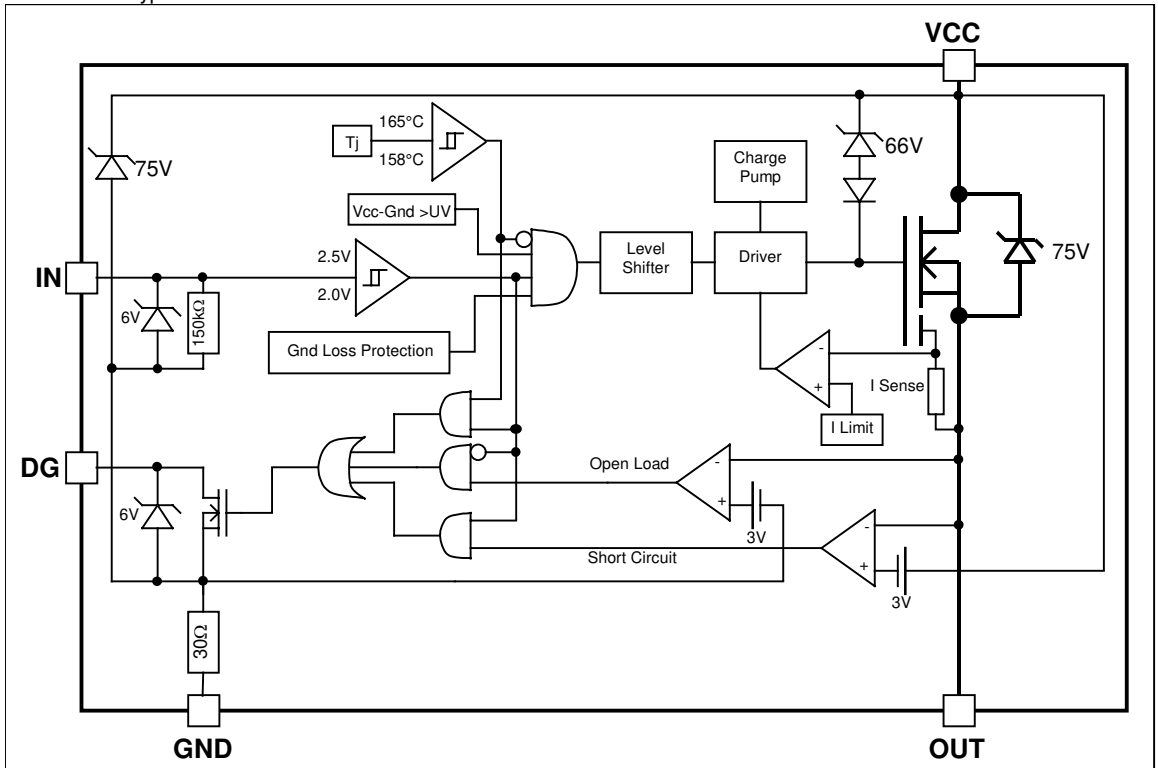

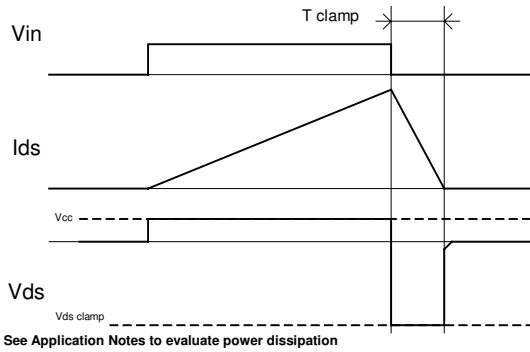

Figure 1 – Active clamp waveforms

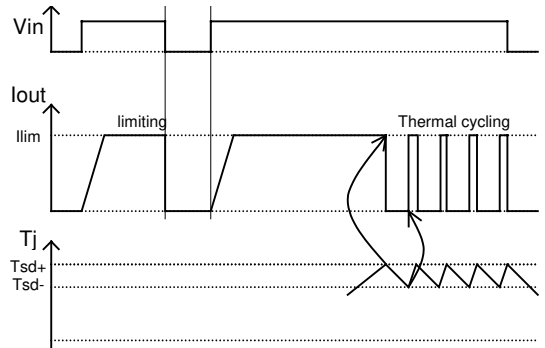

Figure 2 – Protection timing diagram

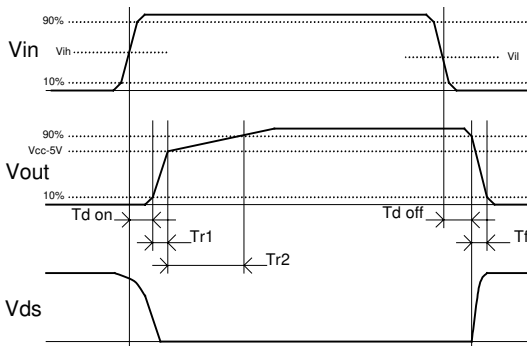

Figure 3 – Switching times definition

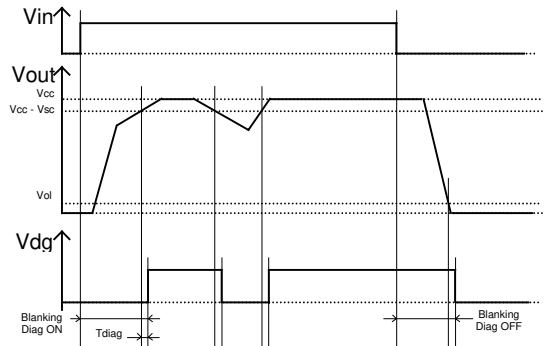

Figure 4 – Diagnostic delay definition

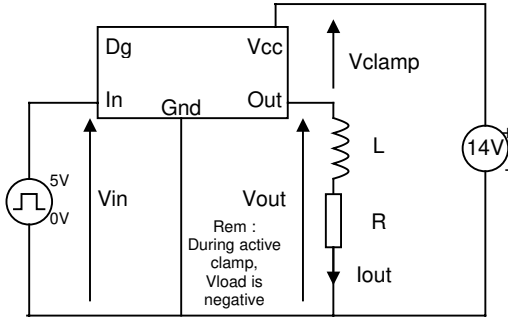

Figure 5 – Active clamp test circuit

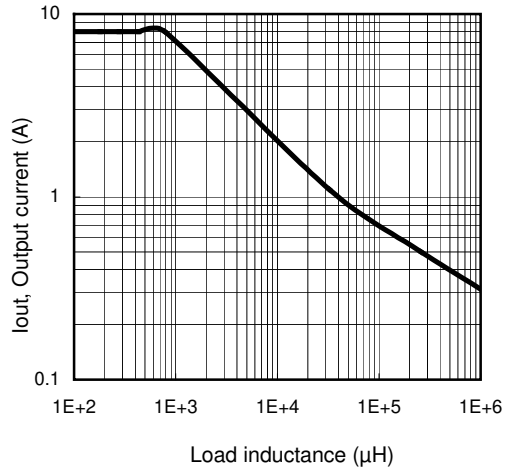

Figure 6 – Max. Output current (A) Vs Load inductance (µH)

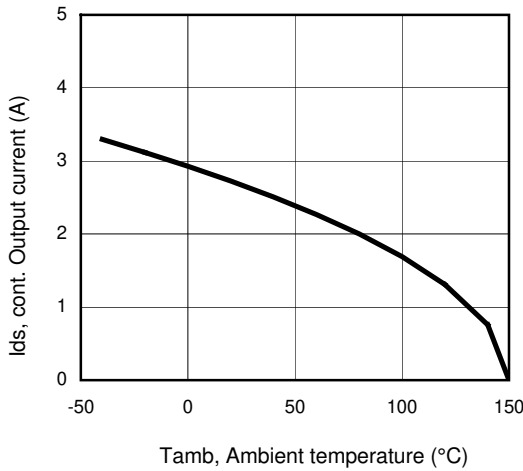

Figure 7 – Max. output current (A) Vs Ambient temperature (°C)

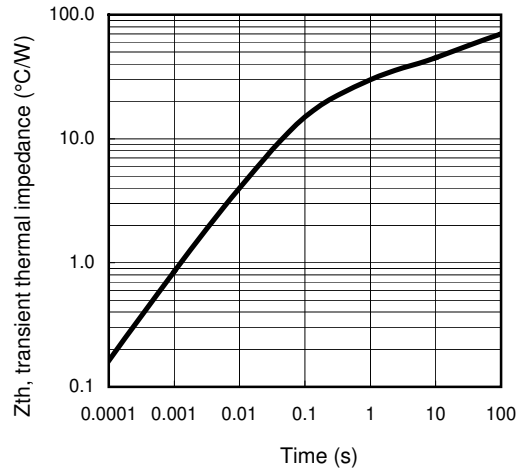
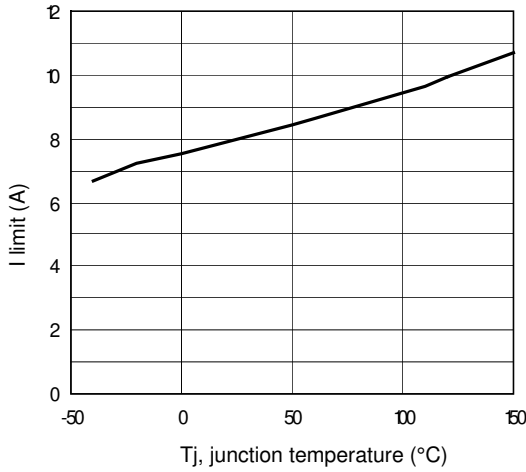
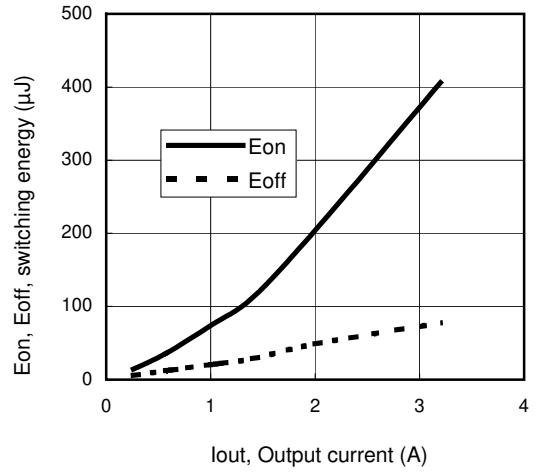

Figure 8 – Transient thermal impedance (°C/W) Vs time (s)



**Figure 9 – I limit (A)
Vs junction temperature (°C)**



**Figure 10 – Switching energy (µJ)
Vs Output current (A)**

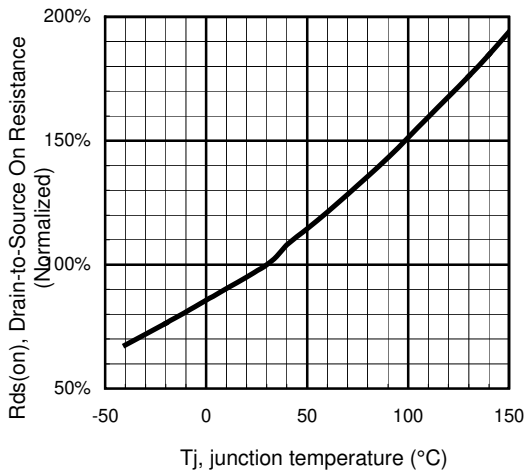
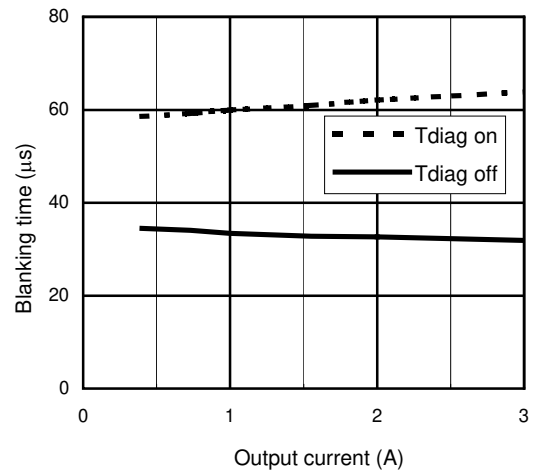

Figure 11 - Normalized R_{ds(on)} (%) Vs T_j (°C)



**Figure 12 – Diagnosis Blanking time (µs)
Vs Output current (A)**

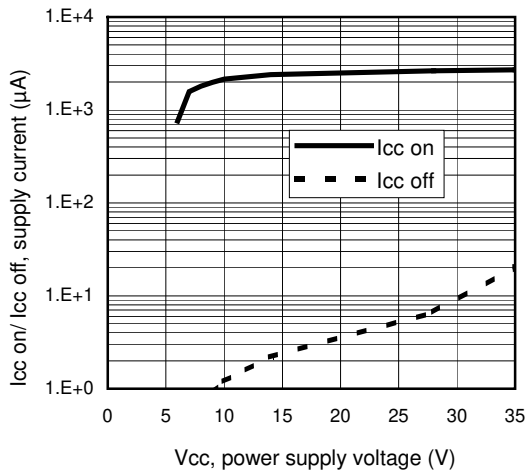

Figure 13 – I_{cc on}/ I_{cc off} (µA) Vs V_{cc} (V)

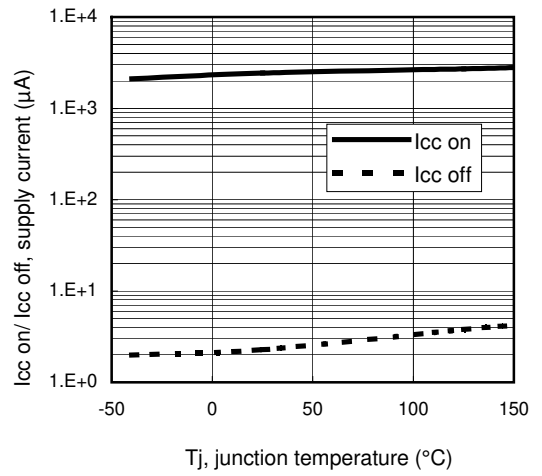
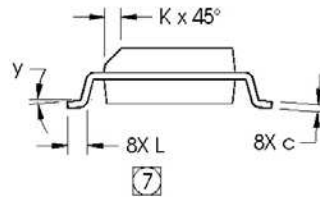
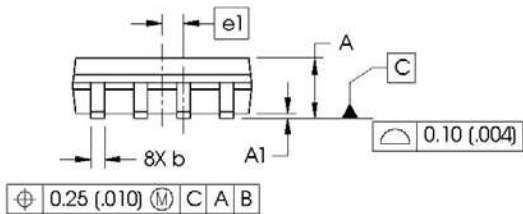
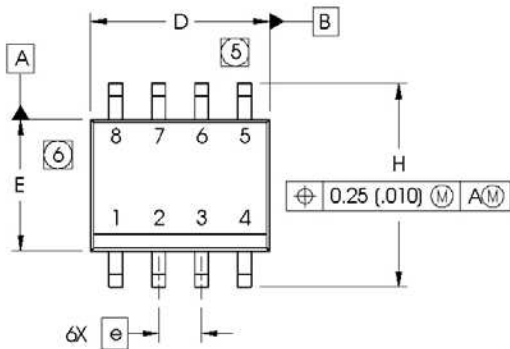

Figure 14 – I_{cc on}/ I_{cc off} (µA) Vs T_j (°C)

Case Outline – SO8

Dimensions are shown in millimeters (inches)



DIM	INCHES		MILLIMETERS	
	MIN	MAX	MIN	MAX
A	.0532	.0688	1.35	1.75
A1	.0040	.0098	0.10	0.25
b	.013	.020	0.33	0.51
c	.0075	.0098	0.19	0.25
D	.189	.1968	4.80	5.00
E	.1497	.1574	3.80	4.00
e	.050 BASIC		1.27 BASIC	
e1	.025 BASIC		0.635 BASIC	
H	.2284	.2440	5.80	6.20
K	.0099	.0196	0.25	0.50
L	.016	.050	0.40	1.27
y	0°	8°	0°	8°

NOTES:

1. DIMENSIONING & TOLERANCING PER ASME Y14.5M-1994.
2. CONTROLLING DIMENSION: MILLIMETER
3. DIMENSIONS ARE SHOWN IN MILLIMETERS (INCHES).
4. OUTLINE CONFORMS TO JEDEC OUTLINE MS-012AA.
5. DIMENSION DOES NOT INCLUDE MOLD PROTRUSIONS. MOLD PROTRUSIONS NOT TO EXCEED 0.15 (.006).
6. DIMENSION DOES NOT INCLUDE MOLD PROTRUSIONS. MOLD PROTRUSIONS NOT TO EXCEED 0.25 (.010).
7. DIMENSION IS THE LENGTH OF LEAD FOR SOLDERING TO A SUBSTRATE.

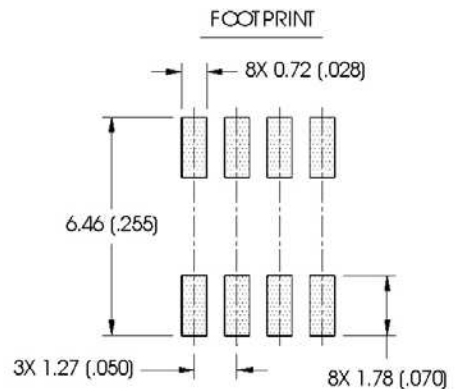

Tape & Reel - SO8

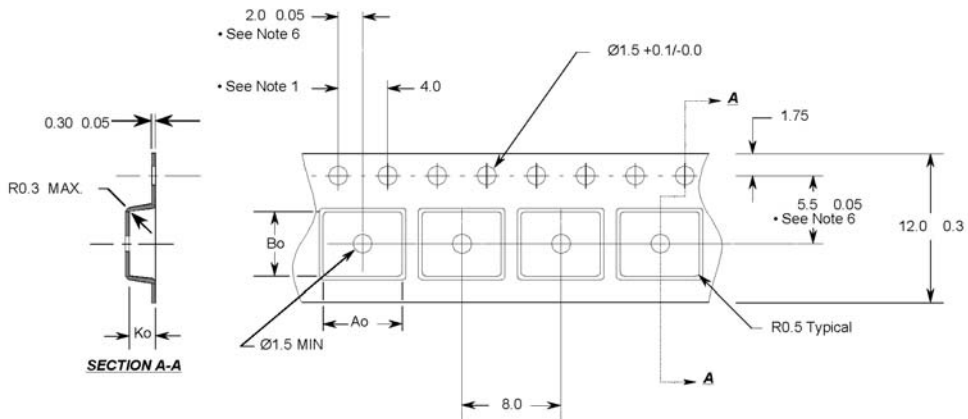

Notes:

1. 10 sprocket hole pitch cumulative tolerance 0.2
2. Camber not to exceed 1mm in 100mm
3. Material: Black Conductive Advantek Polystyrene
4. Ao and Bo measured on a plane 0.3mm above the bottom of the pocket
5. Ko measured from a plane on the inside bottom of the pocket to the top surface of the carrier.
6. Pocket position relative to sprocket hole measured as true position of pocket, not pocket hole.

Ao = 6.4 mm
 Bo = 5.2 mm
 Ko = 2.1 mm

- All Dimensions in Millimeters -