



Chipsmall Limited consists of a professional team with an average of over 10 year of expertise in the distribution of electronic components. Based in Hongkong, we have already established firm and mutual-benefit business relationships with customers from,Europe,America and south Asia,supplying obsolete and hard-to-find components to meet their specific needs.

With the principle of “Quality Parts,Customers Priority,Honest Operation,and Considerate Service”,our business mainly focus on the distribution of electronic components. Line cards we deal with include Microchip,ALPS,ROHM,Xilinx,Pulse,ON,Everlight and Freescale. Main products comprise IC,Modules,Potentiometer,IC Socket,Relay,Connector.Our parts cover such applications as commercial,industrial, and automotives areas.

We are looking forward to setting up business relationship with you and hope to provide you with the best service and solution. Let us make a better world for our industry!



Contact us

Tel: +86-755-8981 8866 Fax: +86-755-8427 6832

Email & Skype: info@chipsmall.com Web: www.chipsmall.com

Address: A1208, Overseas Decoration Building, #122 Zhenhua RD., Futian, Shenzhen, China



Features

- PFC, Ballast Control and Half Bridge Driver in One IC
- Critical Conduction Mode Boost Type PFC
- No PFC Current Sense Resistor Required
- Programmable Preheat Time & Frequency
- Programmable Ignition Ramp
- Programmable Over-Current
- Internal Fault Counter
- End-of-Life Protection
- Lamp Filament Sensing & Protection
- Capacitive Mode Protection
- Brown-Out Protection
- Dynamic Restart
- Automatic Restart for Lamp Exchange
- Thermal Overload Protection
- Programmable Deadtime
- Internal 15.6V Zener Clamp Diode on VCC
- Micropower Startup (150 μ A)
- Latch Immunity and ESD Protection

PFC BALLAST CONTROL IC

Description

The IR2167 is a fully integrated, fully protected 600V ballast control IC designed to drive all types of fluorescent lamps. PFC circuitry provides for high PF, low THD and DC Bus regulation. Externally programmable features such as preheat time & frequency, ignition ramp characteristics, and running mode operating frequency provide a high degree of flexibility for the ballast design engineer. Comprehensive protection features such as protection from failure of a lamp to strike, filament failures, low AC line conditions, thermal overload, or lamp failure during normal operation, as well as an automatic restart function, have been included in the design. The heart of the ballast control section is a variable frequency oscillator with externally programmable deadtime. Precise control of a 50% duty cycle is accomplished using a T-flip-flop.

Packages

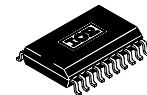

20-Lead SOIC
(wide body)

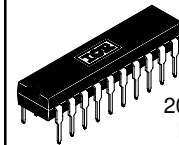

20-Lead
PDIP

Typical Application Diagram

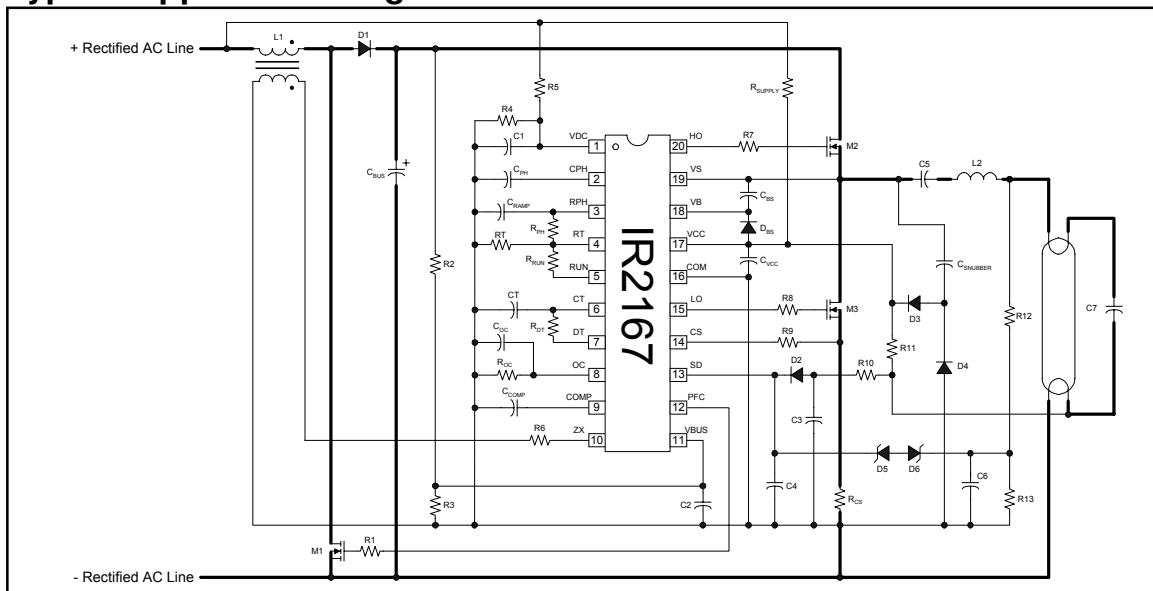

Please note that this datasheet contains advance information that could change before the product is released to production.

IR2167(S) & PbF

Absolute Maximum Ratings

Absolute maximum ratings indicate sustained limits beyond which damage to the device may occur. All voltage parameters are absolute voltages referenced to COM, all currents are defined positive into any lead. The thermal resistance and power dissipation ratings are measured under board mounted and still air conditions.

Symbol	Definition	Min.	Max.	Units	
V _B	High side floating supply voltage	-0.3	625	V	
V _S	High side floating supply offset voltage	V _B - 25	V _B + 0.3		
V _{HO}	High side floating output voltage	V _S - 0.3	V _B + 0.3		
V _{LO}	Low side output voltage	-0.3	V _{CC} + 0.3		
V _{PFC}	PFC gate driver output voltage	-0.3	V _{CC} + 0.3		
I _{OMAX}	Max. allowable output current (HO,LO,PFC) due to external power transistor miller effect	-500	500	mA	
I _{RT}	R _T pin current	-5	5	V	
V _{CT}	C _T pin voltage	-0.3	6.5		
V _{DC}	VDC pin voltage	-0.3	V _{CC} + 0.3		
I _{CPH}	CPH pin current	-5	5		
I _{RPH}	RPH pin current	-5	5		
I _{RUN}	RUN pin current	-5	5	mA	
I _{DT}	Deadtime pin current	-5	5		
V _{CS}	Current sense pin voltage	-0.3	6.5		
I _{CS}	Current sense pin current	-5	5		
I _{OC}	Over-current threshold pin current	-5	5		
I _{SD}	Shutdown pin current	-5	5	V	
V _{BUS}	DC bus sensing input voltage	-0.3	V _{CC}		
I _{ZX}	PFC inductor current, zero crossing detection input	-5	5		
I _{COMP}	PFC error amplifier compensation current	-5	5		
I _{CC}	Supply current (note 1)	-20	20		
dV/dt	Allowable offset supply voltage slew rate	-50	50	V/ns	
P _D	Package power dissipation @ T _A ≤ +25°C	(20 lead PDIP)	—	1.50	W
		(20 lead SOIC)	—	1.25	
R _{thJA}	Thermal resistance, junction to ambient	(20 lead PDIP)	—	85	°C/W
		(20 lead SOIC)	—	90	
T _J	Junction temperature	-55	150	°C	
T _S	Storage temperature	-55	150		
T _L	Lead temperature (soldering, 10 seconds)	—	300		

Recommended Operating Conditions

For proper operation the device should be used within the recommended conditions. All voltage parameters are absolute voltages referenced to COM, all currents are defined positive into any lead

Symbol	Definition	Min.	Max.	Units
V _{BS}	High side floating supply voltage	V _{CC} - 0.7	V _{CLAMP}	V
V _S	Steady state high side floating supply offset voltage	-3.0	600	
V _{CC}	Supply voltage	V _{CCUV+}	V _{CLAMP}	
I _{CC}	Supply current	Note 2	10	mA
V _{DC}	V _{DC} lead voltage	0	V _{CC}	V
I _{SD}	Shutdown lead current	-1	1	mA
I _{CS}	Current sense lead current	-1	1	
C _T	C _T lead capacitance	220	—	pF
R _{DT}	Deadtime resistance	1.0	—	kΩ
I _{RT}	R _T lead current (Note 3)	-500	-50	uA
I _{RPH}	RPH lead current (Note 3)	0	450	
I _{RUN}	RUN lead current (Note 3)	0	450	
I _{ZX}	Zero crossing detection lead current	-1	1	mA
T _J	Junction temperature	-40	125	°C

Electrical Characteristics

V_{CC} = V_{BS} = V_{BIAS} = 14V +/- 0.25V, R_T = 16.9kΩ, C_T = 470 pF, RPH and RUN leads no connection, V_{CPH} = 0.0V, R_{DT} = 6.1kΩ, R_{OC} = 20.0kΩ, V_{CS} = 0.5V, V_{SD} = 2.0V, C_L = 1000pF, T_A = 25°C unless otherwise specified.

Supply Characteristics						
Symbol	Definition	Min.	Typ.	Max.	Units	Test Conditions
V _{CCUV+}	V _{CC} supply undervoltage positive going threshold	10.4	11.4	12.5	V	V _{CC} rising from 0V
V _{UVHYS}	V _{CC} supply undervoltage lockout hysteresis	2.0	2.1	2.1		
I _{QCCUV}	UVLO mode quiescent current	—	250	400	μA	V _{CC} < V _{CCUV-}
I _{QCCFLT}	Fault-mode quiescent current	—	100	350		SD = 5V, CS = 2V or T _J > T _{SD}
I _{QCC}	Quiescent V _{CC} supply current	1.9	3.3	4.5	mA	R _T no connection, C _T connected to COM
I _{CC50K}	V _{CC} supply current, f = 48kHz	4.0	5.0	6.0		
V _{CLAMP}	V _{CC} zener clamp voltage	14.0	15.6	16.5	V	I _{CC} = 10mA

Note 2: Sufficient current should be supplied to the V_{CC} pin to keep the internal 15.6V zener clamp diode on this pin regulating its voltage.

Note 3: Due to the fact that the RT pin is a voltage-controlled current source, the total RT pin current is the sum of all of the parallel current sources connected to that pin. During the preheat mode, the total current flowing out of the RT pin consists of the RPH pin current plus the current due to the RT resistor. During the run mode, the total RT pin current consists of the RUN pin current plus the current due to the RT resistor.

IR2167(S) & PbF

International
IR Rectifier

Electrical Characteristics (cont.)

$V_{CC} = V_{BS} = V_{BIAS} = 14V \pm 0.25V$, $R_T = 16.9k\Omega$, $C_T = 470 pF$, RPH and RUN leads no connection, $V_{CPH} = 0.0V$, $R_{DT} = 6.1k\Omega$, $R_{OC} = 20.0k\Omega$, $V_{CS} = 0.5V$, $V_{SD} = 2.0V$, $C_L = 1000pF$, $T_A = 25^\circ C$ unless otherwise specified.

Floating Supply Characteristics						
Symbol	Definition	Min.	Typ.	Max.	Units	Test Conditions
I_{QBS0}	Quiescent V_{BS} supply current	—	0	10.0	μA	$V_{HO} = V_S$
I_{LK}	Offset supply leakage current	—	0	50		$V_B = V_S = 600V$
PFC Error Amplifier Characteristics						
Symbol	Definition	Min.	Typ.	Max.	Units	Test Conditions
V_{BUS}	V_{BUS} sense input threshold	3.7	4.0	4.3		V
I_{VBUS}	V_{BUS} sense input bias current	—	—	0.1		μA
g_m	Error amplifier transconductance	40	90	130	μmho	RUN mode operation
I_{SOURCE}	Error amplifier output current sourcing	15	30	50	μA	$V_{BUS} = 3V$
I_{SINK}	Error amplifier output current sinking	5	30	50		$V_{BUS} = 5V$
$V_{OH(EA)}$	Error amplifier output voltage swing (Hi state)	12.5	13.5	14.5	V	$V_{BUS} = 3V$
$V_{OL(EA)}$	Error amplifier output voltage swing (Lo state)	—	0.25	0.4		$V_{BUS} = 5V$
PFC Over Voltage Comparator						
Symbol	Definition	Min.	Typ.	Max.	Units	Test Conditions
V_{OV}	Over voltage comparator threshold	4.0	4.3	4.5	V	
PFC Zero Current Detector						
V_{ZX}	ZX lead comparator threshold voltage	1.7	2.0	2.3	V	
V_{ZXhys}	ZX lead comparator hysteresis	400	300	300	mV	
$V_{ZXclamp+}$	ZX lead clamp voltage (high state)	6.0	7.5	9.0	V	$I_{ZX} = 1mA$
Oscillator, Ballast Control, I/O Characteristics						
Symbol	Definition	Min.	Typ.	Max.	Units	Test Conditions
f_{osc}	Oscillator frequency	41	44	47	kHz	$R_T = 16.9k\Omega$, $R_{DT} = 6.1k\Omega$, $C_T = 470pF$
V_{CT+}	Upper C_T ramp voltage threshold	3.6	4.0	4.4	V	
V_{CT-}	Lower C_T ramp voltage threshold	1.8	2.0	2.2		
V_{RT}	R_T lead voltage	1.8	2.0	2.2		
t_{DLO}	LO output deadtime	2.0	2.4	2.6	μsec	
t_{DHO}	HO output deadtime	2.0	2.4	2.6		
Preheat Characteristics						
Symbol	Definition	Min.	Typ.	Max.	Units	Test Conditions
I_{CPH+}	CPH lead charging current	2.5	2.8	3.2	μA	$V_{CPH} = 0V$
I_{CPH-}	CPH lead discharge current	50	175	350	nA	$V_{CPH} = 0V$
V_{CPHIGN}	CPH lead Ignition mode threshold voltage	3.6	4.1	4.4	V	
V_{CPHRUN}	CPH lead run mode threshold voltage	4.7	5.1	5.5		
$V_{CPHCLMF}$	CPH lead clamp voltage	6	10	11.5		$I_{CPH} = 1\mu A$

Electrical Characteristics (cont.)

$V_{CC} = V_{BS} = V_{BIAS} = 14V \pm 0.25V$, $R_T = 16.9k\Omega$, $C_T = 470 \text{ pF}$, RPH and RUN leads no connection, $V_{CPH} = 0.0V$, $R_{DT} = 6.1k\Omega$, $R_{OC} = 20.0k\Omega$, $V_{CS} = 0.5V$, $V_{SD} = 2.0V$, $C_L = 1000\text{pF}$, $T_A = 25^\circ\text{C}$ unless otherwise specified.

RPH Characteristics						
Symbol	Definition	Min.	Typ.	Max.	Units	Test Conditions
I_{RPHLK}	Open circuit RPH lead leakage current	—	0.1	—	μA	$V_{RPH} = 5V, V_{RPH} = 6V$
RUN Characteristics						
Symbol	Definition	Min.	Typ.	Max.	Units	Test Conditions
I_{RUNLK}	Open circuit RUN lead leakage current	—	0.1	—	μA	$V_{RUN} = 5V$
Protection Circuitry Characteristics						
Symbol	Definition	Min.	Typ.	Max.	Units	Test Conditions
V_{SDTH+}	Rising shutdown lead threshold voltage	4.8	5.25	5.4	V	
V_{SDHYS}	Shutdown lead threshold hysteresis	300	150	100	mV	
V_{SDEOL+}	Rising shutdown lead end-of-life threshold voltage	2.6	3.0	3.4	V	
V_{SDEOL-}	Falling shutdown lead end-of-life threshold voltage	0.7	1.0	1.3		
V_{CSTH+}	Over-current sense threshold voltage	1.05	1.2	1.35		
V_{CSTH-}	Under-current sense threshold voltage	0.14	0.23	0.28		
T_{CS}	Over-current sense propagation delay	50	350	550	nsec	Delay from CS to LO
#FAULT cycles	Number of sequential over-current Fault cycles before IC shuts down (IGN Mode)	25	50	75	cycles	$4V < V_{CPH} < 5.1V$, cycles @ $CS > 1.3V$
V_{VDC+}	Low V_{BUS} /rectified line input upper threshold	4.8	5.2	5.7	V	
V_{VDC-}	Low V_{BUS} /rectified line input lower threshold	2.7	3.1	3.5		
T_{SD}	Thermal shutdown junction temperature	—	160	—	$^\circ\text{C}$	Note 4
Gate Driver Output Characteristics						
Symbol	Definition	Min.	Typ.	Max.	Units	Test Conditions
V_{OL}	Low level output voltage (PFC, LO or HO)	—	0	100	mV	$I_o = 0$
V_{OH}	High level output voltage (PFC, LO or HO)	—	0	100		$V_{BIAS} - V_O, I_o = 0$
t_r	Turn-on rise time (PFC, LO or HO)	50	85	200	nsec	
t_f	Turn-off fall time (PFC, LO or HO)	25	45	100		

Note 4: When the IC senses an overtemperature condition ($T_J > 160^\circ\text{C}$), the IC is latched off. In order to reset this Fault Latch, the SD lead must be cycled high and then low, or the V_{CC} supply to the IC must be cycled below the falling undervoltage lockout threshold (V_{CCUV}).

IR2167(S) & PbF

Lead Assignments

Pin Assignments		Pin #	Symbol	Description
VDC	1	20	HO	DC Bus Sensing Input
CPH	2	19	VS	Preheat Timing Capacitor
RPH	3	18	VB	Preheat Frequency Resistor & Ignition Capacitor
RT	4	17	VCC	Oscillator Timing Resistor
RUN	5	16	COM	Run Frequency Resistor
CT	6	15	LO	Oscillator Timing Capacitor
DT	7	14	CS	Deadtime Programming
OC	8	13	SD	Over-current (CS+) Threshold Programming
COMP	9	12	PFC	Error Amplifier Compensation
ZX	10	11	VBUS	Zero-Crossing, PFC Inductor
				Bus Voltage Sense Input
				PFC Gate Driver Output
				Shutdown Input
				Current Sensing Input
				Low-Side Gate Driver Output
				IC Power & Signal Ground
				Logic & Low-Side Gate Driver Supply
				High-Side Gate Driver Floating Supply
				High Voltage Floating Return
				High-Side Gate Driver Output

State Diagram

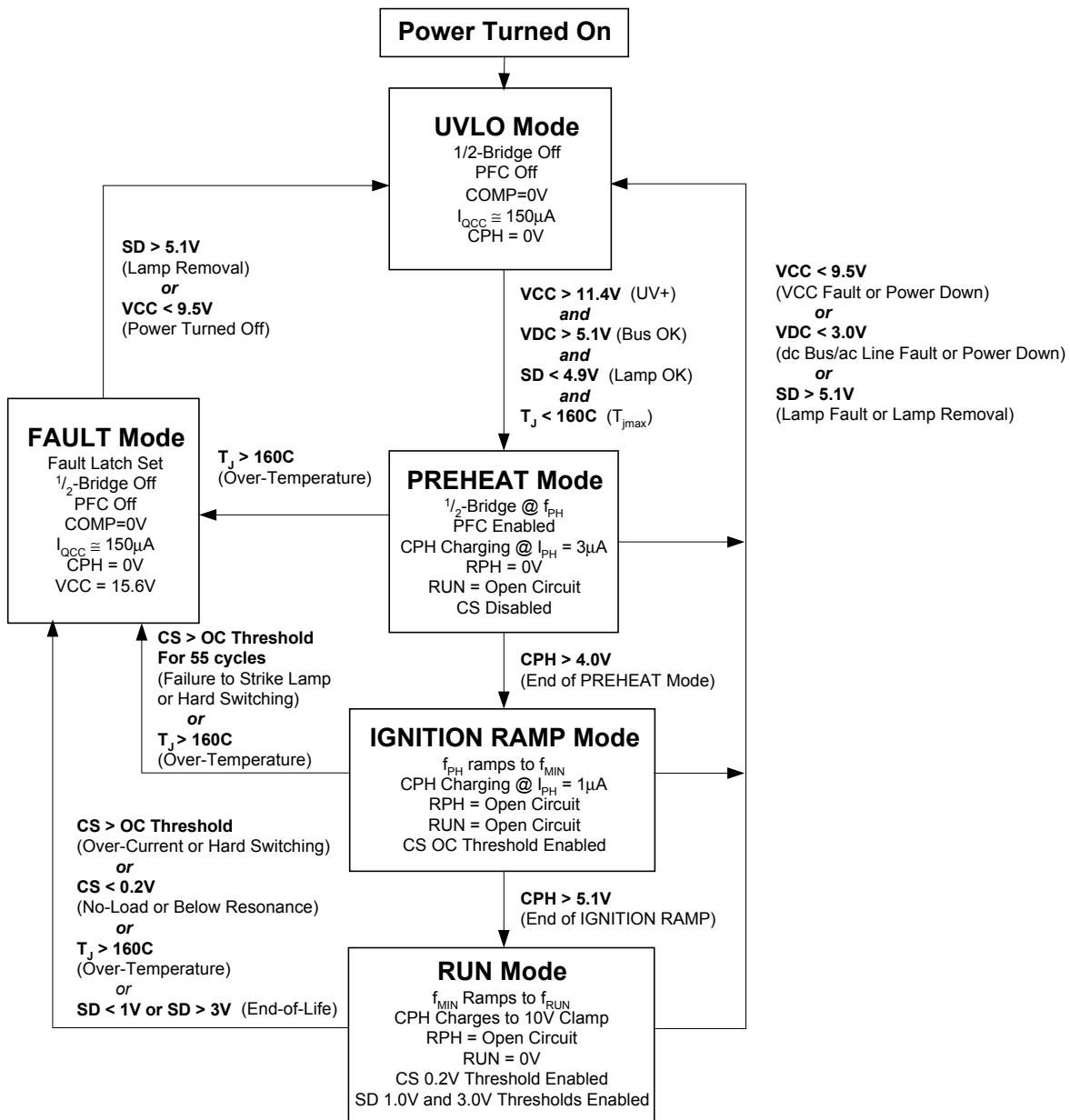

All values are typical

IR2167(S) & PbF

Functional Block Diagram

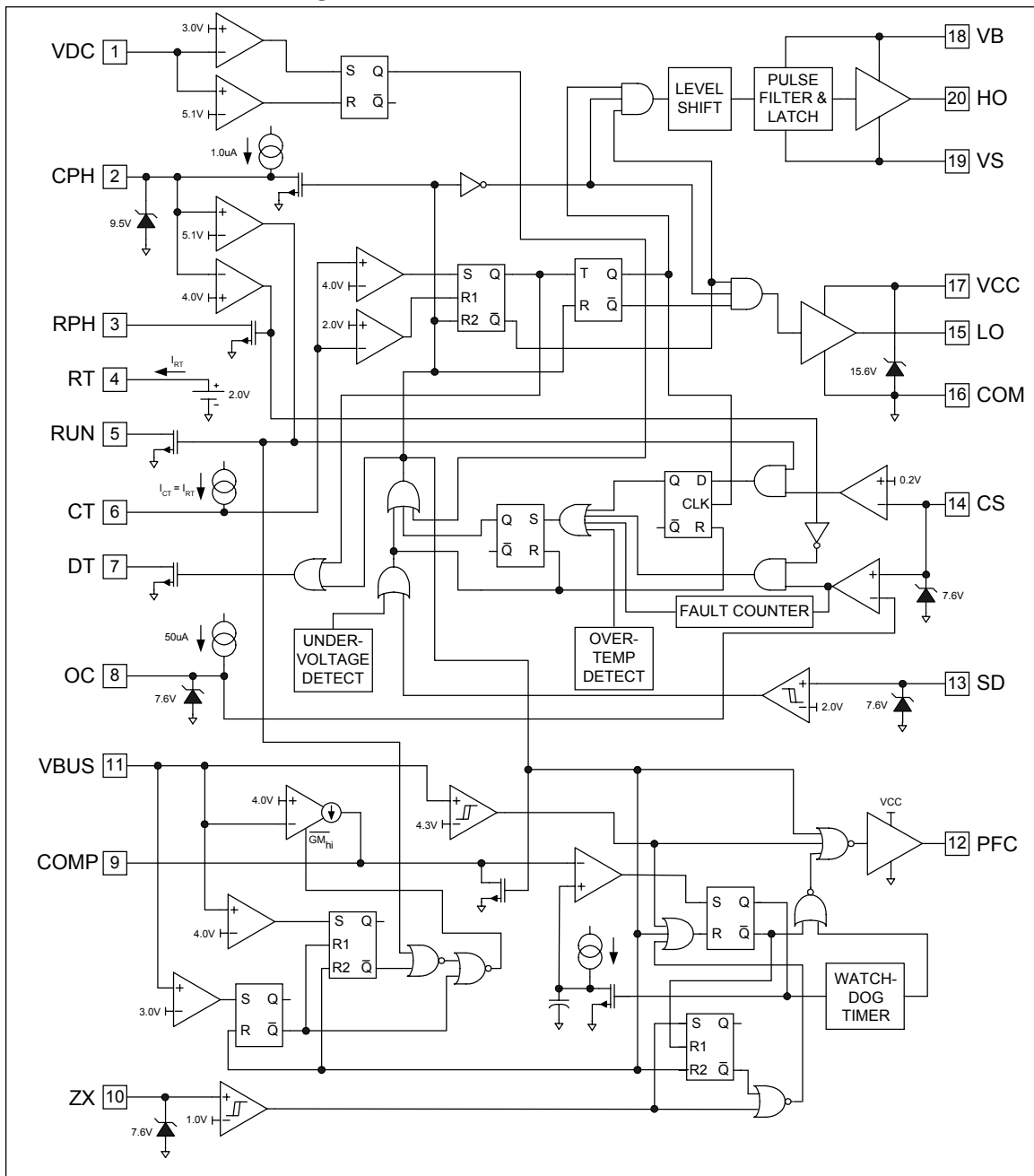

**BALLAST CONTROL SECTION
TIMING DIAGRAMS
NORMAL OPERATION**

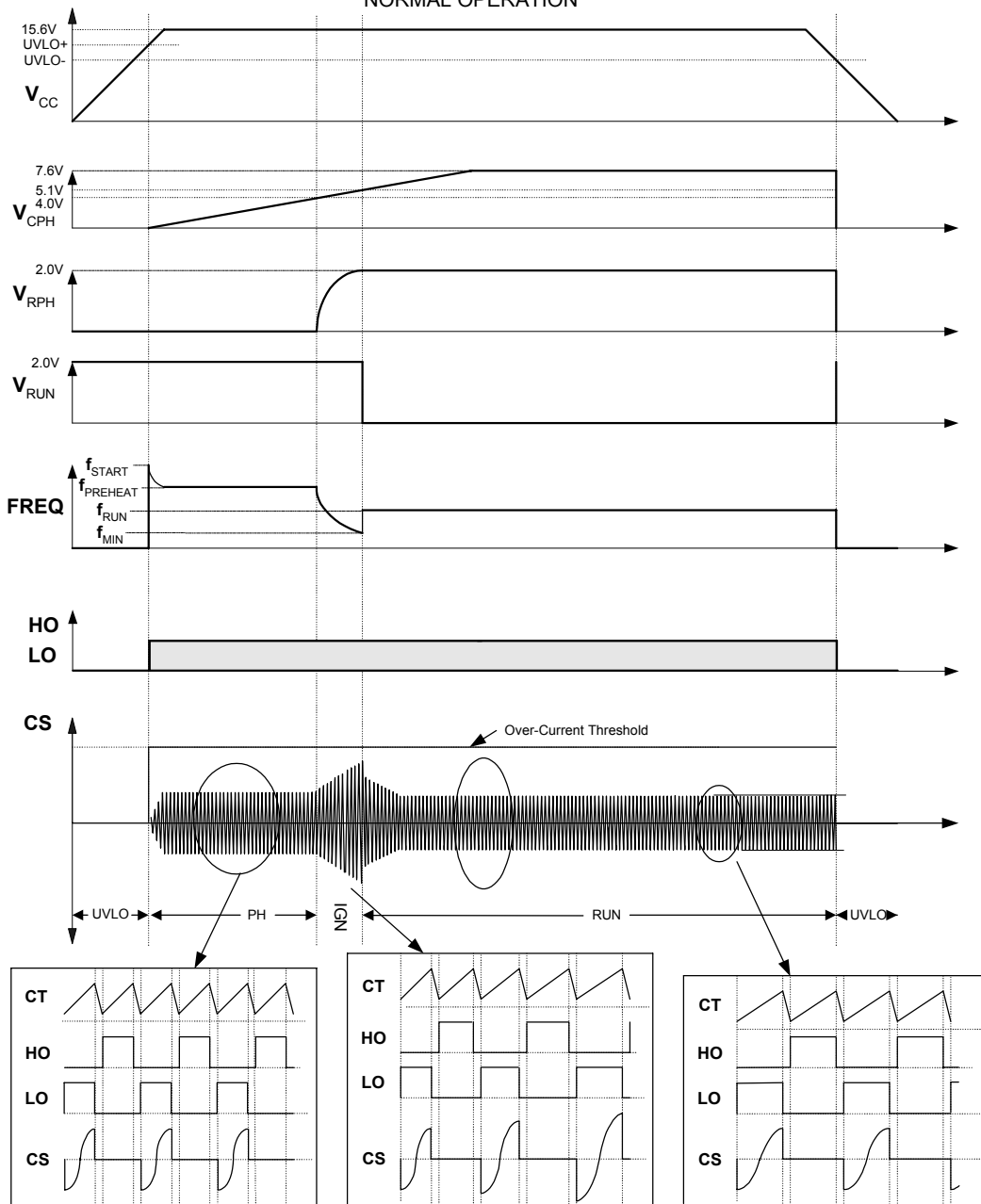

BALLAST CONTROL SECTION TIMING DIAGRAMS FAULT CONDITION

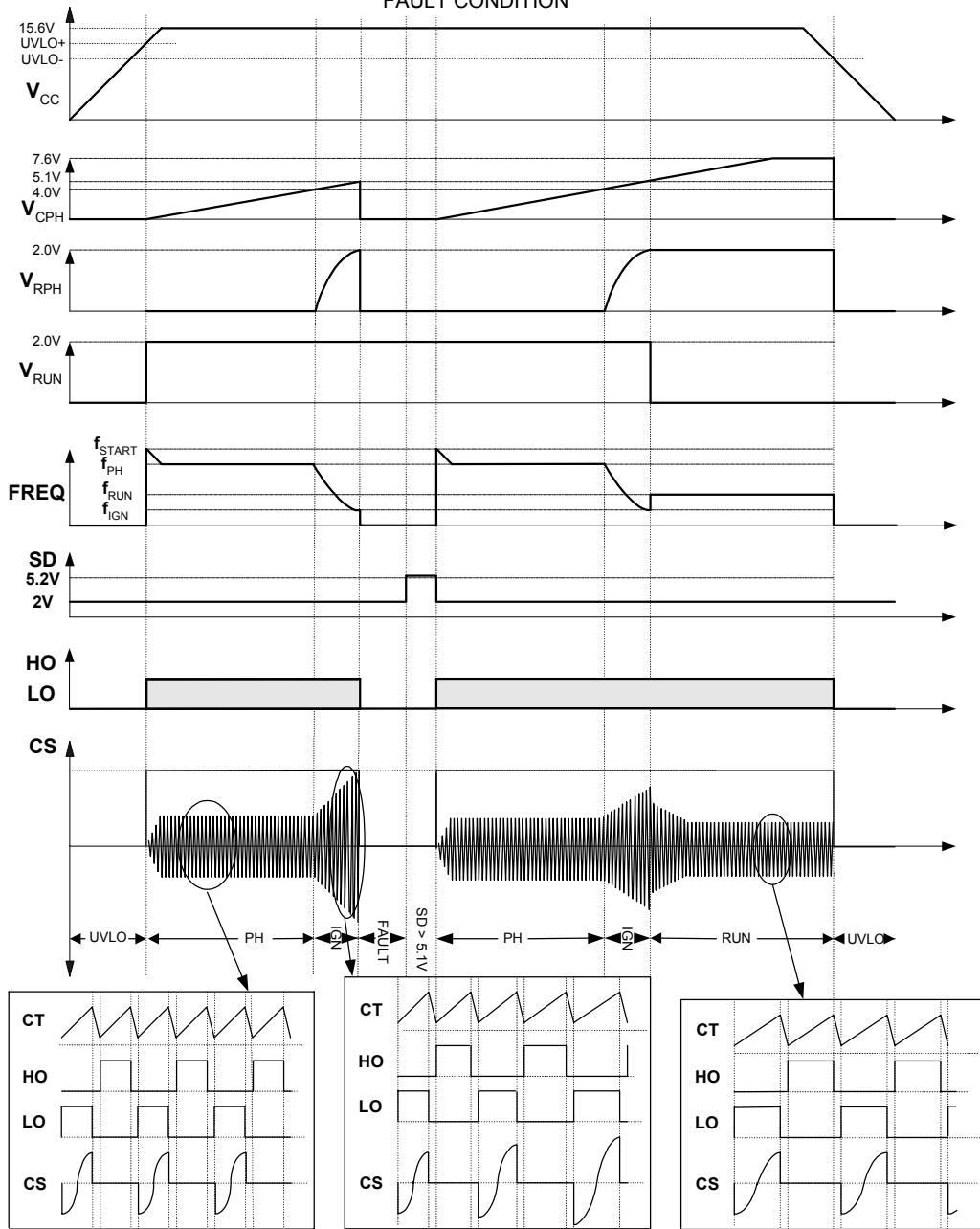

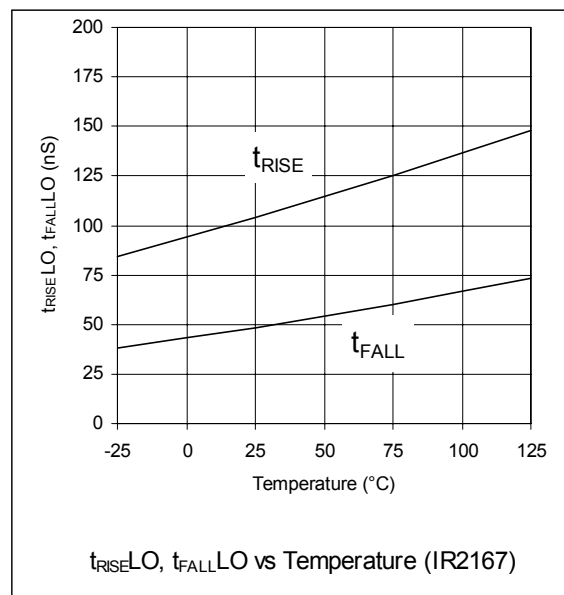
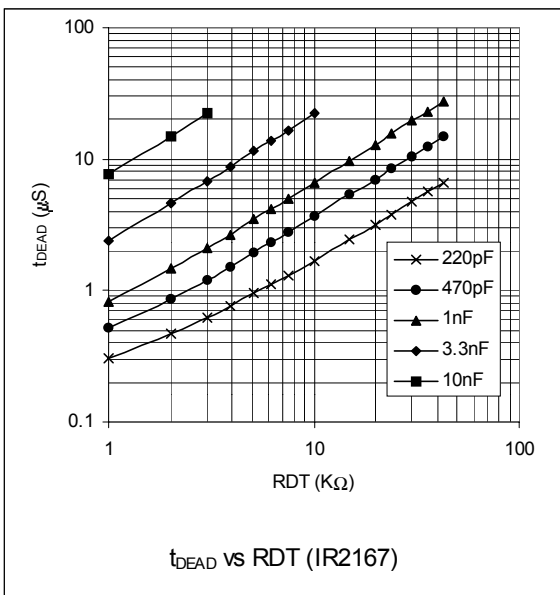
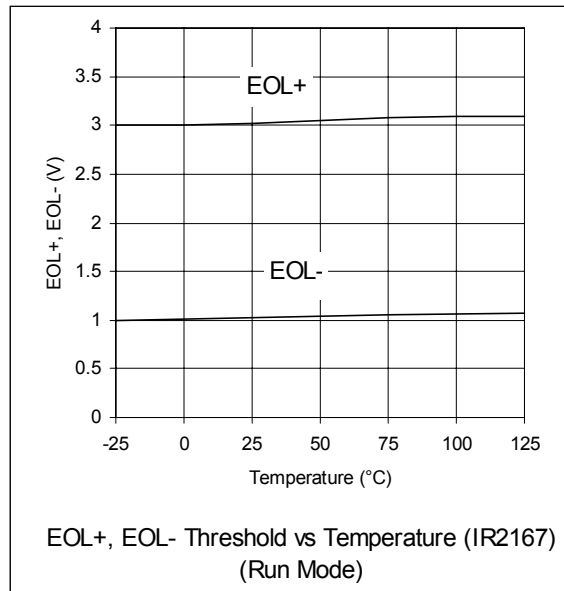
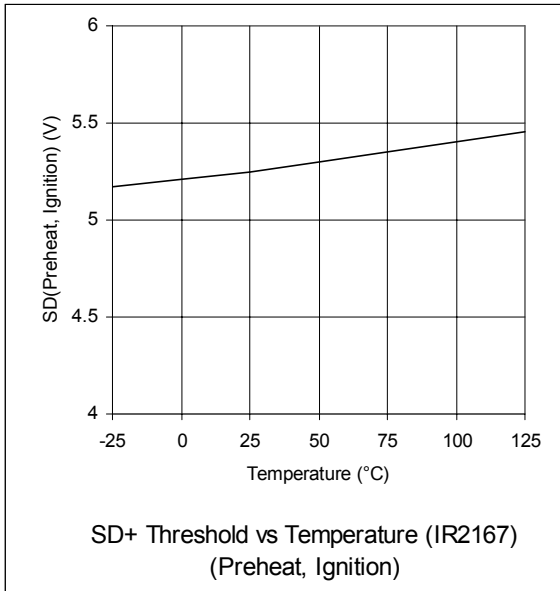

IR2167(S) & PbF

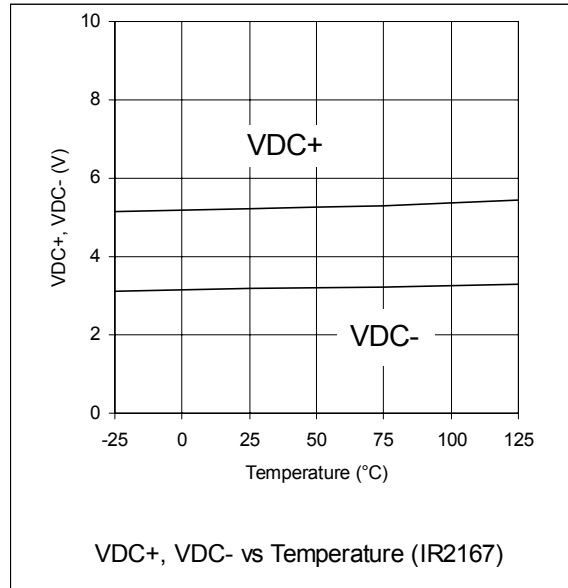
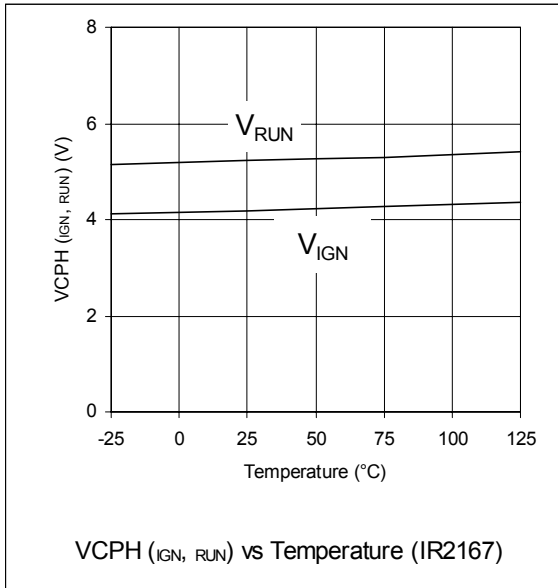
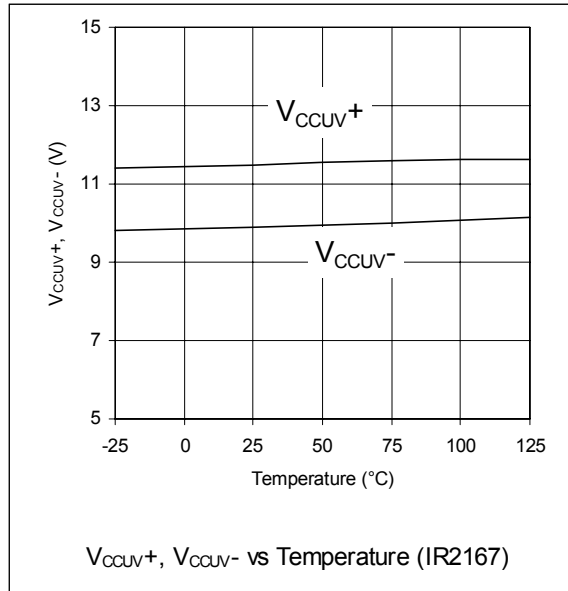
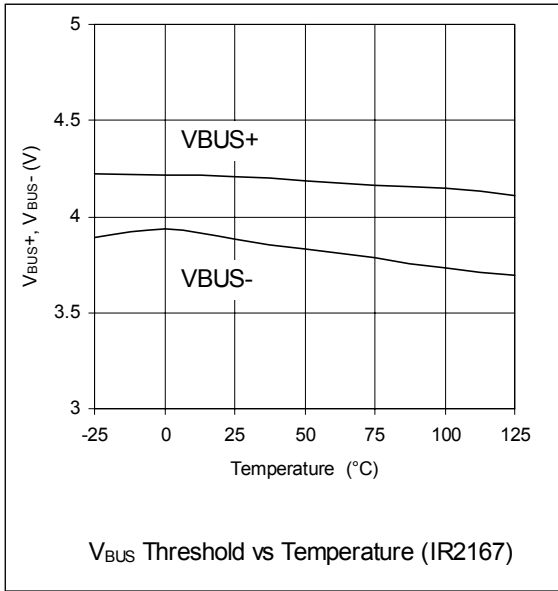

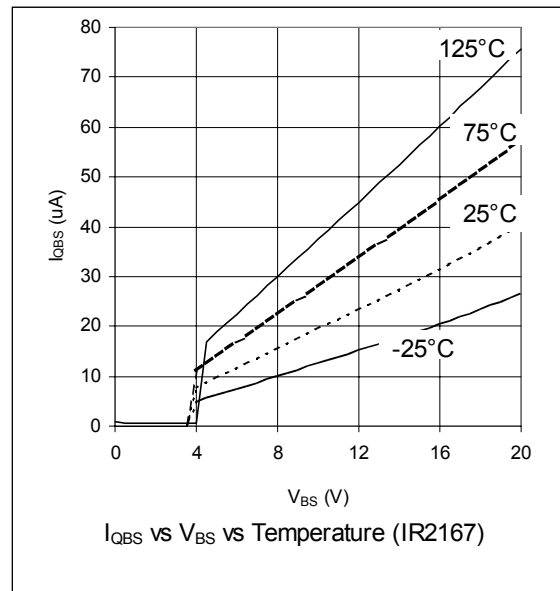
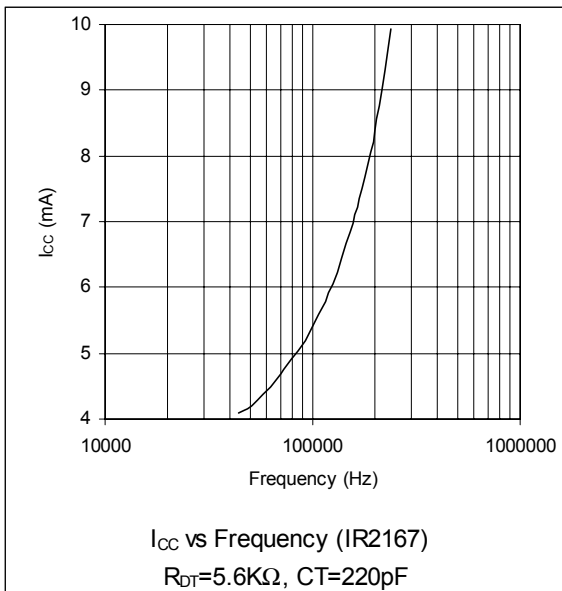
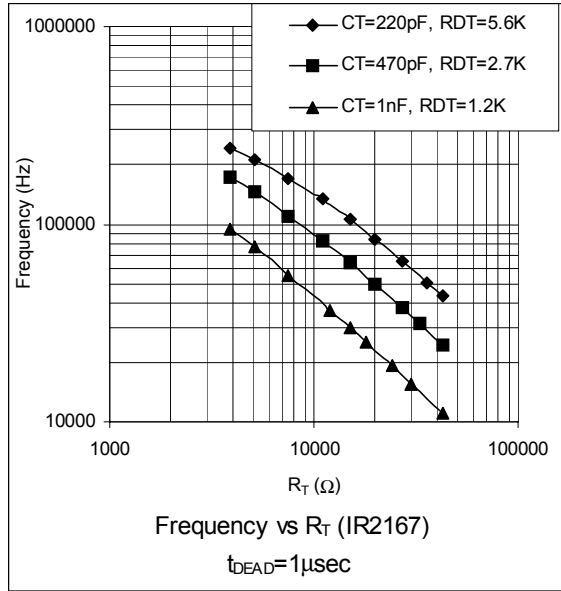
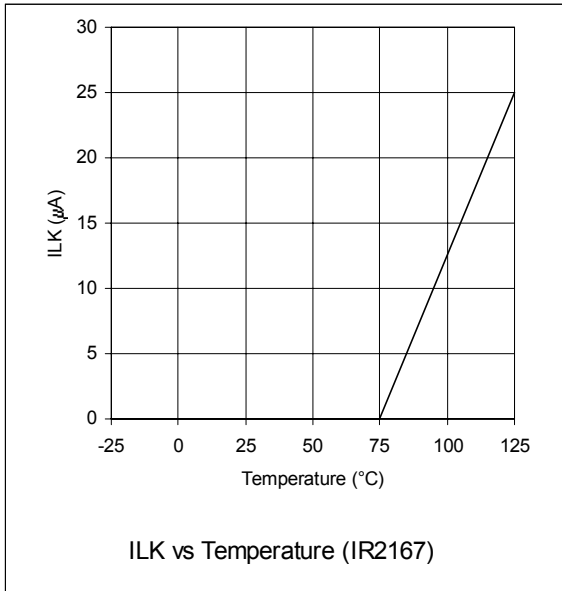

IR2167(S) & PbF

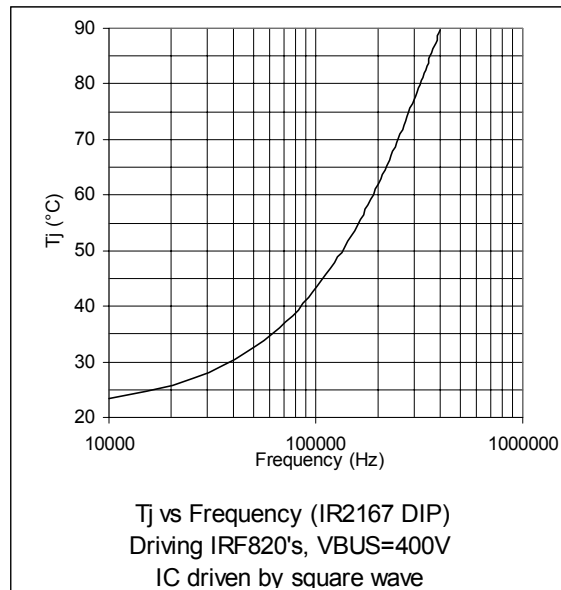
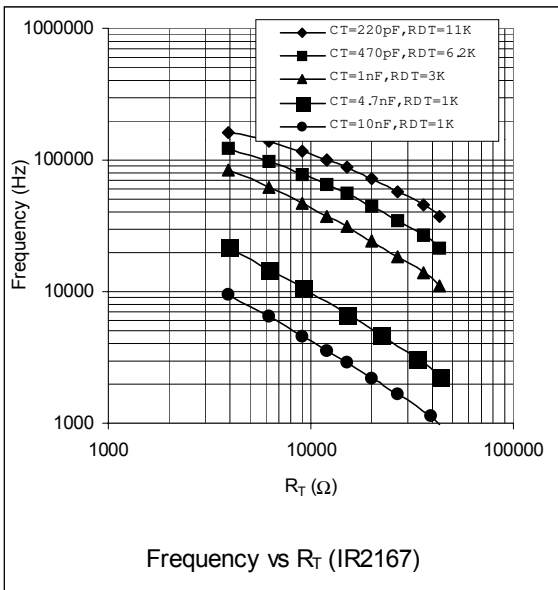

Functional Description

Under-voltage Lock-Out Mode (UVLO)

The under-voltage lock-out mode is defined as the state the IC is in when VCC is below the turn-on threshold of the IC. (To identify the different modes of the IC, refer to the State Diagram shown on page 7 of this document). During under-voltage lock-out mode, the HO, LO and PFC driver outputs are low and the CT pin is connected to COM through resistor R_{DT} to disable the oscillator. Also, the internal supply to the RT pin circuitry is shut off and pins CPH, RUN, DT and COMP are internally pulled to COM. The IR2167 under-voltage lock-out mode is designed to maintain a very low supply current of less than $200\mu A$, and to guarantee the IC is fully functional before the high side, low side and PFC drivers are activated. Figure 1 shows an efficient supply using the start-up current of the IR2167 together with a charge pump from the ballast stage (R_{SUPPLY} , C_{VCC} , DCP1 and DCP2).

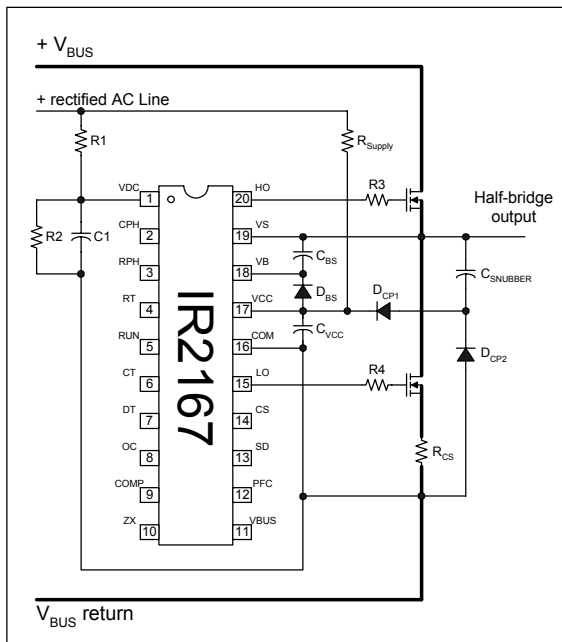

Figure 1: Start-up and supply circuitry

The Vcc capacitor (C_{VCC}) is charged by current through supply resistor (R_{SUPPLY}) minus the start-up current drawn

by the IC. The value of (R_{SUPPLY}) is chosen to provide 2X the maximum start-up current to guarantee ballast start-up at low line input voltage. Once the capacitor voltage on the VCC pin reaches the start-up threshold, the SD lead is below 5.1 volts and V_{VDC} is greater than 5.1V, the IC turns on and LO and HO begin to oscillate. PFC does not begin to oscillate until the IC reaches Preheat Mode.

Preheat Mode Startup Mode

The IR2167 enters Preheat mode when VCC exceeds the UVLO positive-going threshold. Before Preheat mode begins, the CPH and RPH pins are connected to COM. (See Figure 3). As Preheat begins, the external capacitor CPH is charged up by an internal $3\mu A$ current source. CPH determines the preheat time which continues until the voltage on the CPH pin charges to 4.0V. Preheat mode is defined as the state the IC is in when the lamp filaments are being heated to their correct emission temperature. This is necessary for maximizing lamp life and reducing the required ignition voltage. At the onset of Preheat Mode, C_{VCC} begins to discharge due to the increase in IC operating current (Figure 2) above the available current through resistor R_{SUPPLY} . However, the half-bridge output also begins to oscillate and the charge pump, consisting of $C_{SNUBBER}$, DCP1 and DCP2, supply the current to charge capacitor C_{VCC} and thus the voltage to the IC. The VCC voltage supplied to the IC is

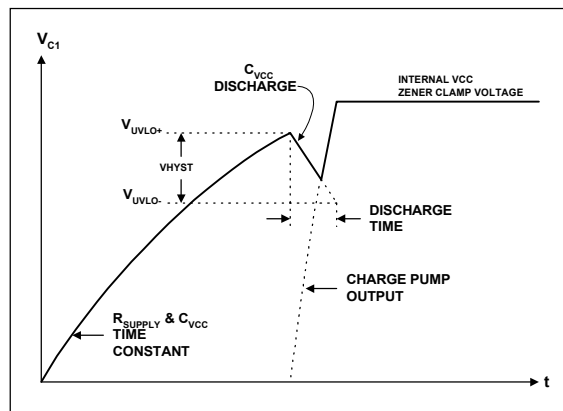

Figure 2: Supply Capacitor (C_{VCC}) voltage

limited by the internal 15.6V zener clamp. C_{VCC} and $C_{SNUBBER}$ must be selected such that enough supply current

IR2167(S) & PbF

is available over all ballast operating conditions. Bootstrap diode (D_{BS}) and supply capacitor (C_{BS}) comprise the supply voltage for the high-side driver circuitry. To guarantee that the high-side supply is charged up before the first pulse on HO, the first pulse from the output drivers comes from the LO pin.

The Preheat mode oscillation frequency of the half-bridge output is determined by the parallel combination of RPH and RT with the values of CT, RDT and an internal circuit as

turns off and CRAMP begins to charge. CRAMP determines the time it takes for the oscillator to ramp down from the Preheat frequency to the Ignition Mode frequency. Once the voltage on the RPH lead reaches 2.0V, external resistor RPH has no effect on the frequency that is now determined by external components RT, CT and RDT. This is the minimum frequency. By this time, the oscillator will have ramped down toward the resonance of the load circuit causing the lamp to ignite.

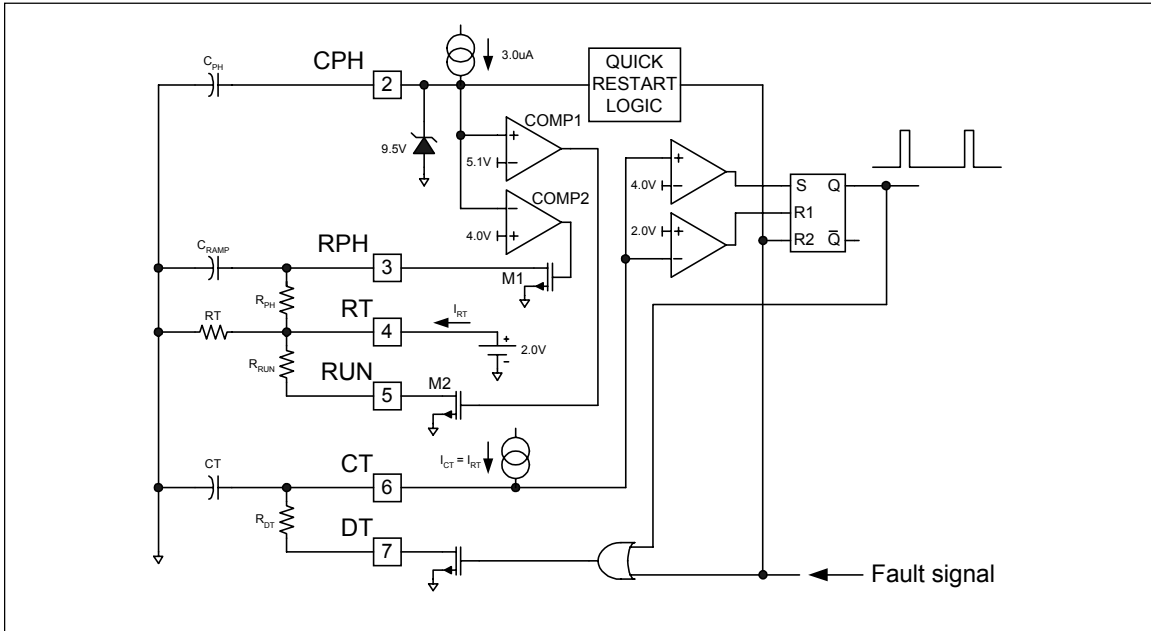

Figure 3: Oscillator section block diagram with external component connection

shown in Figure 3. Note that at the onset of Preheat mode the initial startup frequency is much higher than the preheat frequency. The half-bridge output frequency then ramps down from this initial start-up frequency to the Preheat mode frequency. This is to ensure that the instantaneous voltage across the lamp during the first few cycles of operation does not exceed the strike potential of the lamp.

Ignition Mode

When the CPH pin charges up to 4.0V, ignition mode begins. At this time, the output of COMP2 (figure 3) goes low, M1

Run Mode

When the voltage on the CPH pin reaches 5.1V, the IC enters Run mode. At this time, the output of COMP1 (figure 3) goes high which turns M2 on and pulls the RUN pin to COM. The frequency is now controlled by external components RT, RRUN, CT and RDT. In certain cases it is necessary to have the run frequency higher than the ignition frequency to control the power used by the load. Figure 4 shows the ballast control sequence explained in the previous paragraphs.

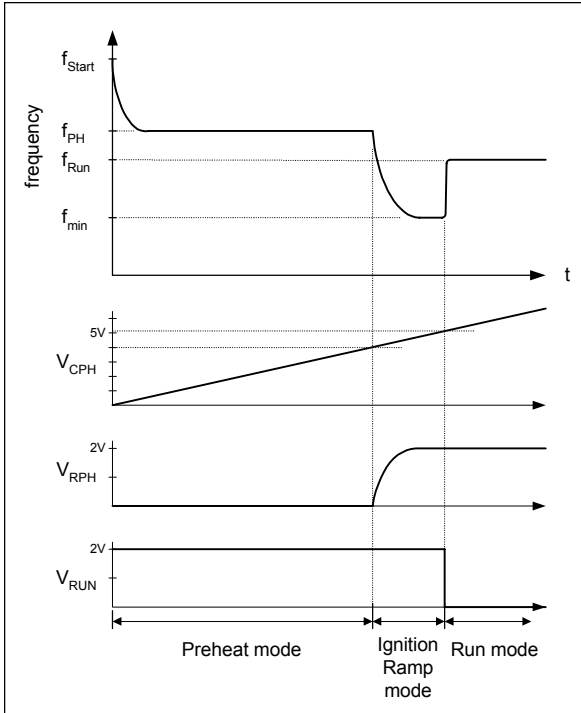

Figure 4: IR2167 Ballast Control Sequence

The control sequence used in the IR2167 allows the Run mode operating frequency of the ballast to be higher than the ignition frequency (i.e., $f_{start} > f_{ph} > f_{run} > f_{ign}$). This control sequence is recommended for lamp types where the ignition frequency is too close to the run frequency to ensure proper lamp striking for all production resonant LC component tolerances (please note that it is possible to use the IR2167 in systems where $f_{start} > f_{ph} > f_{ign} > f_{run}$, simply by leaving the RUN pin open).

The heart of this controller is an oscillator that resembles those found in many popular PWM voltage regulator ICs. In its simplest form, this oscillator consists of a timing resistor and capacitor connected to ground. The voltage across the timing capacitor C_T is a sawtooth, where the rising portion of the ramp is determined by the current in the RT lead, and the falling portion of the ramp is determined by an external deadtime resistor R_{DT} . The oscillograph in Figure 5 illustrates the relationship between the oscillator capacitor waveform and the gate driver outputs.

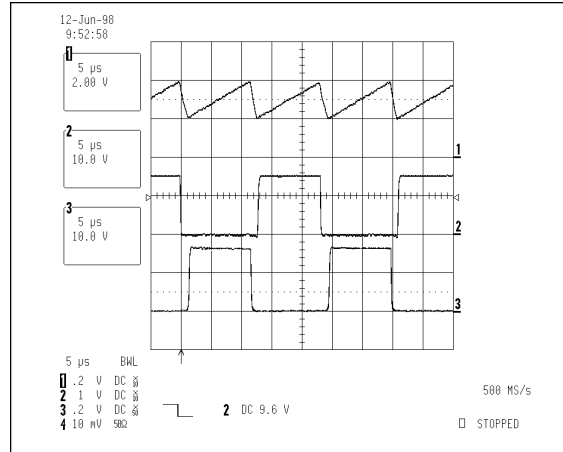

Figure 5: Oscillator Waveforms

This falling portion of the sawtooth waveform is referred to as deadtime, during which both HO and LO outputs are low. The deadtime can be programmed by means of the external R_{DT} resistor.

The RT input is a voltage-controlled current source, where the voltage is regulated to be approximately 2.0V. In order to maintain proper linearity between the RT pin current and the CT capacitor charging current, the value of the RT pin current should be kept between $50\mu A$ and $500\mu A$. The RT pin can also be used as a feedback point for closed loop control.

PFC Section

In most AC to DC power converters it is necessary to have the circuit act as a pure resistive load to the AC input line voltage. To achieve this, active power factor correction (PFC) can be implemented which, for an AC input line voltage, produces an AC input line current. It is also important to produce a sinusoidal input current which has a low total harmonic distortion (THD) and a high power factor (PF) (See Figure 6).

IR2167(S) & PbF

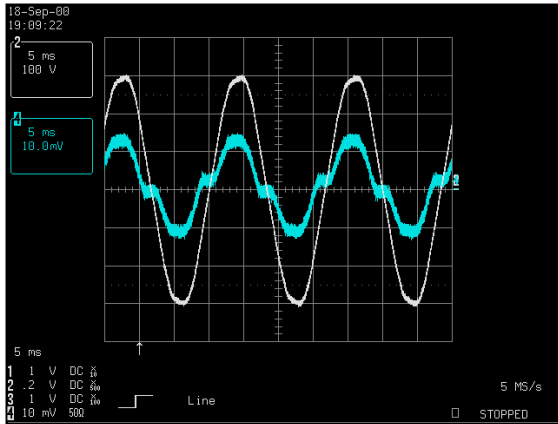

Figure 6: Input Voltage & Current
PF=0.96, THD=22%

The approach used in the IR2167 is classified as running in critical conduction mode, in which the inductor current discharges to zero with each switching cycle. There is no need to sense the rectified AC line input voltage because it is already sinusoidal. Therefore, the inductor current will naturally follow the sinusoidal voltage envelope as the PFC MOSFET is turned on and off at a much higher frequency (>10KHz) than the line input frequency (50 to 60Hz). The circuit compares the DC Bus voltage to a fixed reference voltage to determine the on-time of the PFC MOSFET. The off-time is determined by the time it takes the L_{PFC} current to drop to zero. This zero current level is detected by a secondary winding in L_{PFC} that is connected to the ZX pin. The result is a system where the switching frequency is free-running and constantly changing from a high frequency near the zero crossing of the AC input line voltage, to a lower frequency at the peaks. (See Figures 7, 8 & 9).

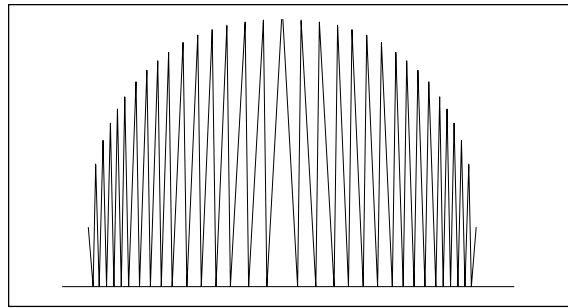

Figure 7: Inductor Current

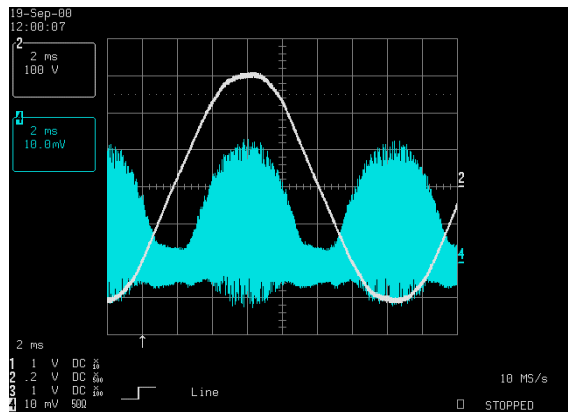

Figure 8: Boost Inductor Envelope & Line Voltage

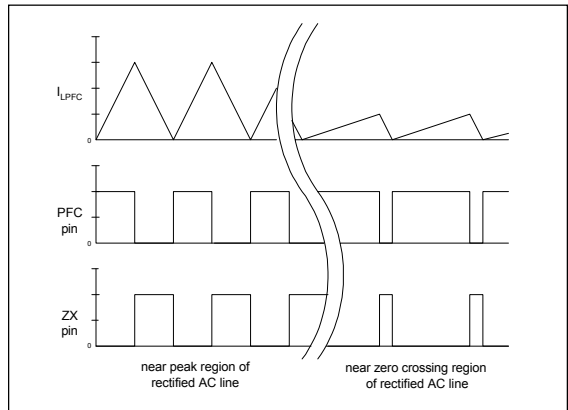

Figure 9: Boost FET On Time vs Line Input

As the external capacitor on the COMP pin begins to charge, the PFC MOSFET on time duration increases. The gain of OTA1 is at its maximum value (See Figures 10 & 11). Maximum gain is desirable to raise the Bus voltage to its nominal value as quickly as possible. When the voltage at the VBUS pin reaches 3V, the gain of OTA1 decreases to its

MOSFET is turned on with minimum on time and L_{PFC} is shorted to ground and begins charging. The PFC MOSFET then turns off and L_{PFC} begins to discharge into the DC BUS capacitor.

COMP4 has a 4.3V threshold with hysteresis so that if the voltage at the VBUS pin overshoots the 4.3V threshold,

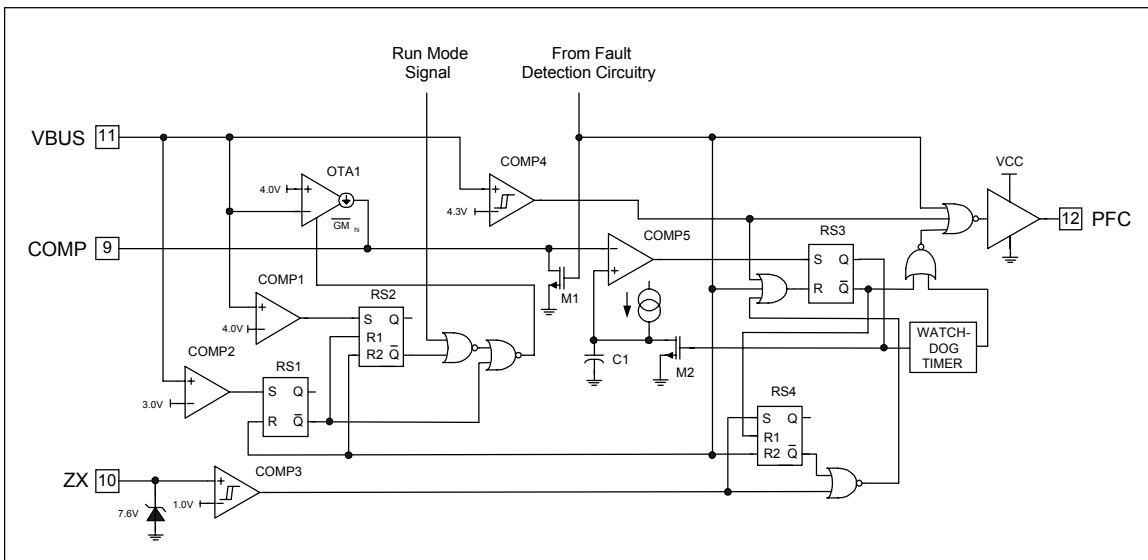

Figure 10: PFC Section

nominal value. The BUS voltage continues to increase to its nominal value at which time the voltage measured at the VBUS pin equals 4V. The gain of OTA1 now increases to its maximum value and remains there until the Run mode. This is necessary because if VBUS overshoots its nominal value, the circuit can react quickly to correct the error. Also, during ignition, there is a sudden increase in load current which can cause the Bus voltage to sag. With maximum gain, OTA1 can quickly restore the DC Bus voltage to its nominal value.

When the AC line voltage is applied to the ballast, V_{CC} rises to 15V. The PFC section is not enabled until the beginning of the Preheat mode of operation. By not enabling the PFC section until the beginning of the Preheat mode, the DC Bus voltage in the ballast is not yet boosted to its nominal running value. This helps alleviate the initial flash of the lamp when the half-bridge driver section first begins to switch.

When the PFC circuit is first enabled, (See Figure 10), the voltage at the VBUS and COMP pins is low. The PFC

MOSFET will not turn on again until the voltage at the VBUS pin drops to approximately 4.0V. This effectively limits the maximum bus voltage to approximately 8% greater than the regulated level.

In some instances, the line voltage may be too high. This causes the AC rectified line current to directly charge the DC Bus capacitor without being boosted. Since the current never drops to zero, the ZX pin never goes high and the PFC MOSFET never turns on. The Watch Dog Timer circuit provides a pulse to turn on the PFC MOSFET if no pulse is detected at the ZX pin for 500mS. This enables the PFC circuitry to regulate the DC Bus voltage at its nominal value

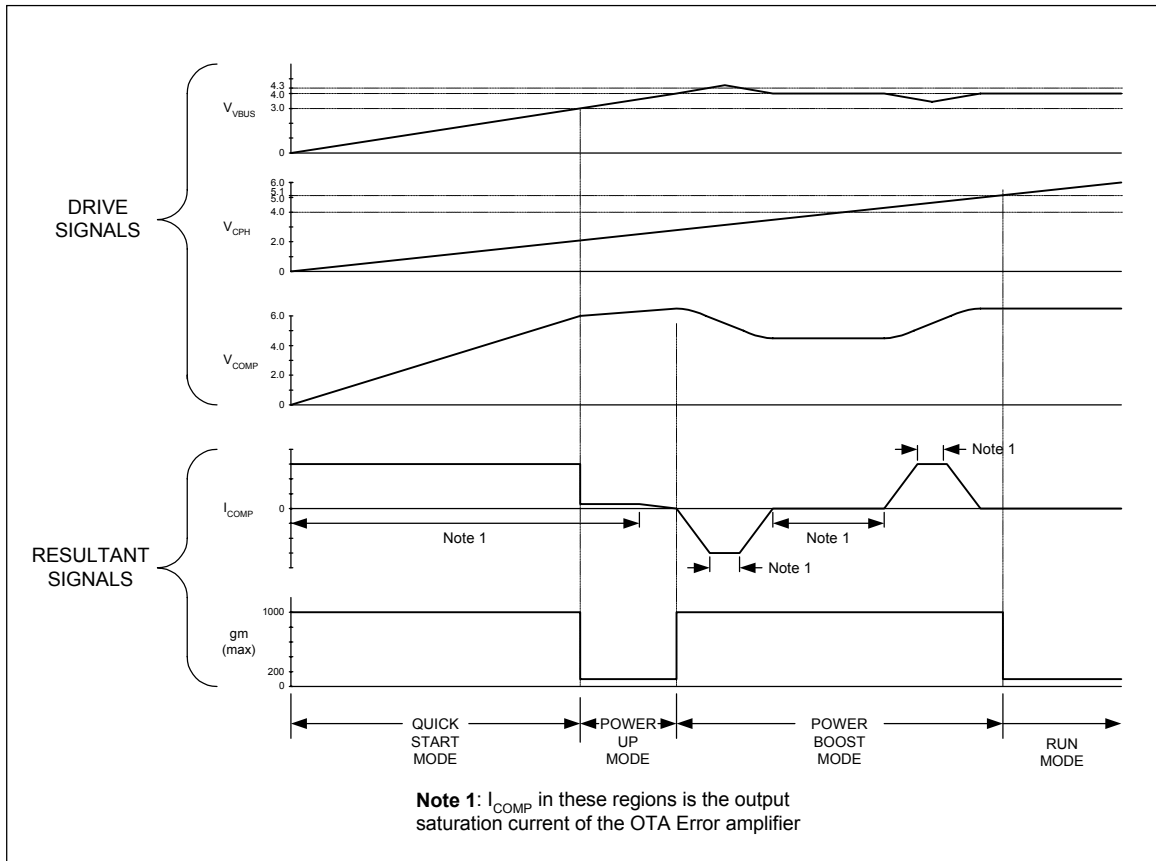

Figure 11: PFC Timing Sequence

PFC Over-Current Protection (optional)

In case of fast on/off interruptions of the mains input voltage or during normal lamp ignition, the DC bus voltage level can decrease below the instantaneous rectified line voltage. Should this occur, the PFC inductor current and PFC MOSFET current can increase to high levels causing the PFC inductor to saturate and/or the PFC MOSFET to become damaged. During fast on/off interruptions of the input mains voltage, the DC bus can drop during the time when the mains voltage is interrupted (off). Since VCC is still above UVLO-, the IC will continue to operate and will increase the COMP pin voltage to increase the PFC MOSFET on-time due to the dropping of the DC bus. When the mains voltage returns again quickly, (before VCC reaches UVLO-), the on-time of the PFC MOSFET is too long for the given mains voltage level resulting in high PFC inductor and MOSFET currents that can saturate the inductor and/or damage the PFC MOSFET (Figure 12).

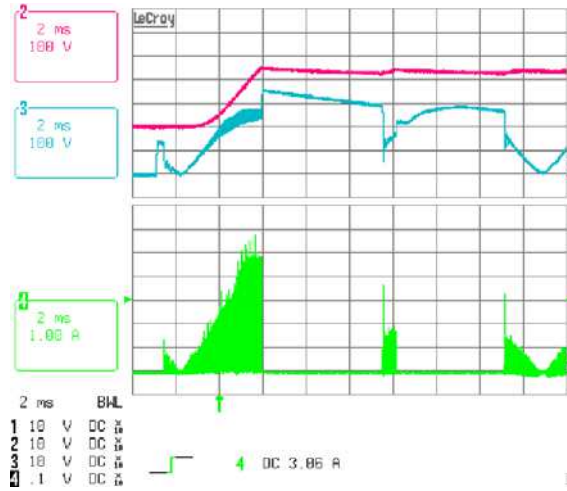
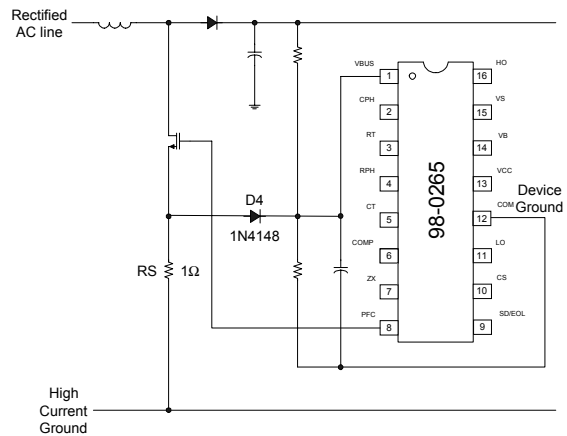

Figure 12, High PFC inductor current during fast mains on/off (upper trace: DC Bus, 100V/div; middle trace: AC line input voltage, 100V/div; lower trace: PFC inductor current 1A/div).

During lamp ignition, the DC bus can drop below the rectified AC line voltage causing current to conduct directly from the output of the rectifier, through the PFC inductor and diode, to the DC bus capacitor. This results in a low-frequency offset of current in the PFC inductor. Since the zero-crossing detection circuit only detects the high-frequency zero-crossing of the inductor current, the PFC MOSFET will turn on again each cycle before the inductor current has reached zero. This causes the PFC to work in a continuous conduction mode and the sum of the low-frequency and high-frequency components of current can saturate the PFC inductor and/or damage the PFC MOSFET.

To protect against these conditions, a current sense resistor (RS) can be inserted between the source on the PFC MOSFET and ground, and a diode (D4) connected from the top of this current-sensing resistor to the VBUS pin (Figure 13).



13, External over-current protection circuit

IR2167(S) & PbF

Should high currents occur, the voltage across the current-sensing resistor (RS) will exceed the 4.3V over-voltage protection threshold at the VBUS pin and the PFC MOSFET will turn off safely limiting the current. The watch-dog timer will then restart the PFC as normal (Figure 14). The current sensing resistor value should be selected such that the over-current protection does not false trip during normal operation over the entire line voltage range and load range. A current-sensing resistor value, for example, of 1.0 W will set the over-current protection threshold to about 5 A peak.

when the DC bus drops during ignition (the 3V reset on the VBUS pin does not become active until RUN mode). For these reasons, the ballast designer should perform these mains interrupt and ignition tests carefully to determine the robustness of their final design and to decide if this additional over-current protection circuit is necessary.

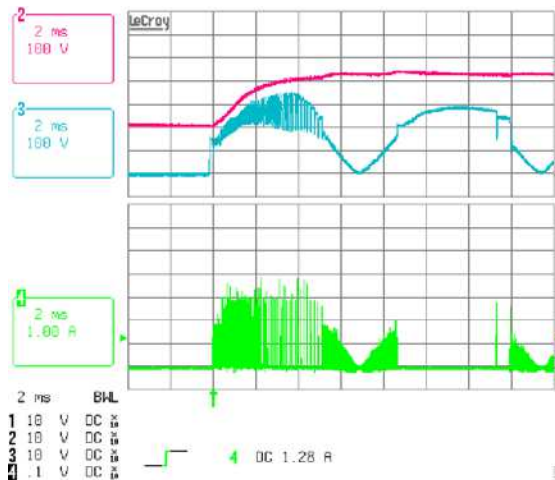

Figure 14, PFC inductor current limited using over-current protection circuit (upper trace: DC Bus, 100V/div; middle trace: AC line input voltage, 100V/div; lower trace: PFC inductor current 1A/div).

The effect that these line and load conditions have on the performance of the ballast depends on the saturation level of the PFC inductor, the selection of the PFC MOSFET, the DC bus capacitor value, the maximum on-time limit set by DZCOMP, and, how fast VCC decreases below UVLO-

Lamp Protection & Automatic Restart Circuitry Operation

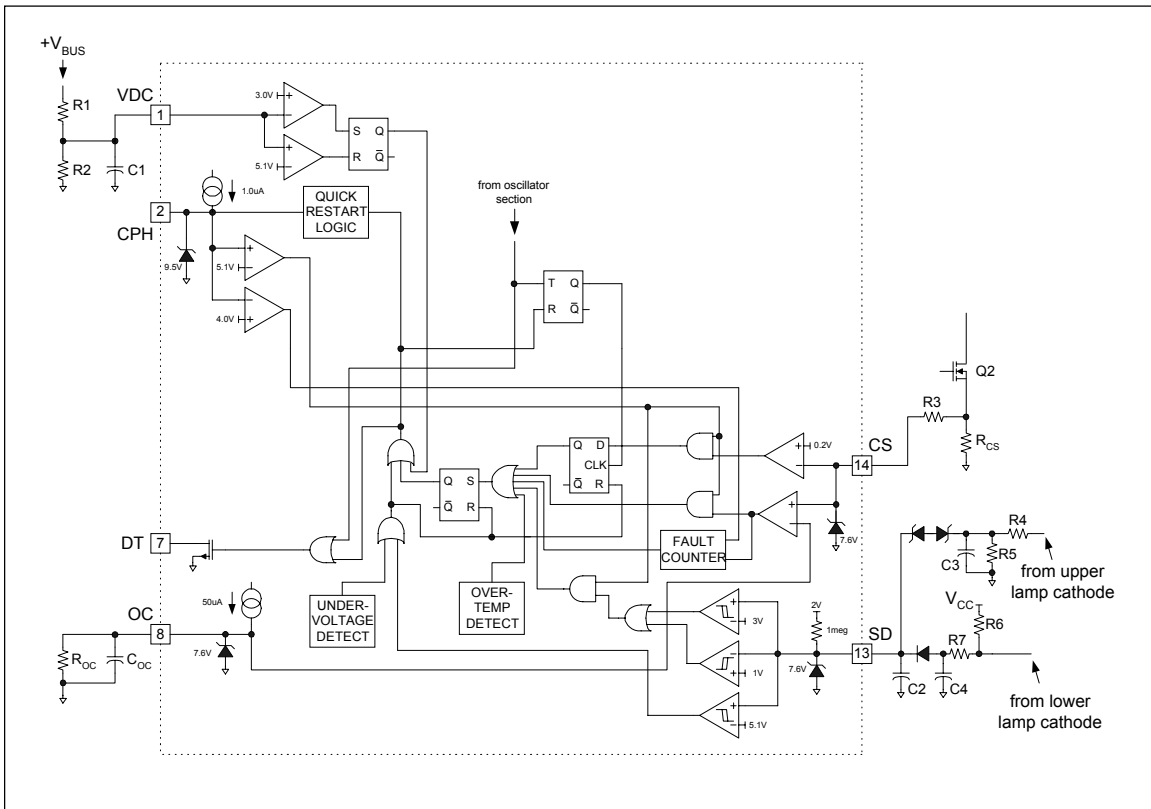

Figure 15: Lamp Protection & Automatic Restart circuitry block diagram with external component connection

Sensing the AC Line Voltage

The first of these protection pins senses the voltage on the AC line by means of an external resistor divider (R1, R2 and capacitor C1) and an internal comparator with hysteresis. When power is first supplied to the IC at system startup, three conditions are required before oscillation is initiated: 1.) the voltage on the VCC pin must exceed the rising undervoltage lockout threshold (11.5V), 2.) the voltage at the VDC pin must exceed 5.1V, and 3.) the voltage on the SD pin must be below approximately 4.85V. If a low ac line condition occurs during normal operation, or if power to the ballast is shut off, the ac line will collapse prior to the VCC of

the chip (assuming theVCC is derived from a charge pump off of the output of the half-bridge). In this case, the voltage on the VDC pin will shut the oscillator off, thereby protecting the power transistors from potentially hazardous hard switching. Approximately 2V of hysteresis has been designed into the internal comparator sensing the VDC pin, in order to account for variations in the ac line voltage under varying load conditions. When the ac line recovers, the chip restarts from the beginning of the control sequence, as shown in timing diagram (See Figure 16).

IR2167(S) & PbF

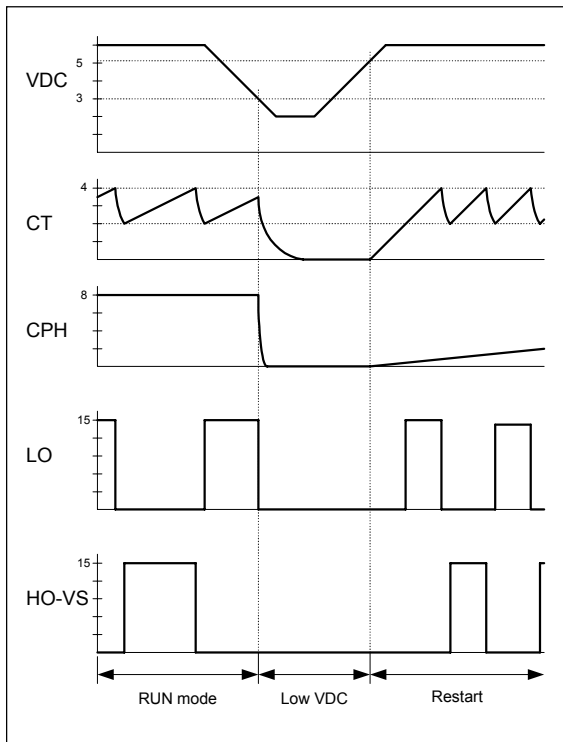

Figure 16: VDC lead fault and auto restart

Lamp Presence and End-of-Life Detection

The second protection pin, SD, is used for both shutdown and end-of-life detection. The SD pin would normally be connected to an external circuit that senses the presence of the lamp(s) and the voltage appearing across the lamp(s). An example circuit for a single lamp is shown in Figure 17. During all modes of operation if the SD pin exceeds 5.1V (approximately 150mV of hysteresis is included to increase noise immunity), signaling either a lamp fault or lamp removal, the oscillator is disabled, both gate driver outputs are pulled low, and the chip is put into the micropower mode. Since a lamp fault would normally lead to a lamp exchange, when a new lamp is inserted in the fixture, the SD pin would be pulled back to near ground potential. Under these conditions a reset signal would restart the chip from the beginning of the control sequence, as shown in the timing diagram in Figure 18. Thus, for a lamp removal and replace-

ment, the ballast automatically restarts the lamp in the proper manner.

In the Run mode there are two additional thresholds enabled on the SD pin: 1V and 3V. These thresholds form a window and during normal lamp running the voltage appearing at the SD pin is maintained within these two levels. As a lamp nears its end-of-life, its running voltage will increase and the signal applied to the SD pin detects this by exceeding the window threshold width. The oscillator is disabled, both gate driver outputs are pulled low, and the chip is put into the micropower mode.

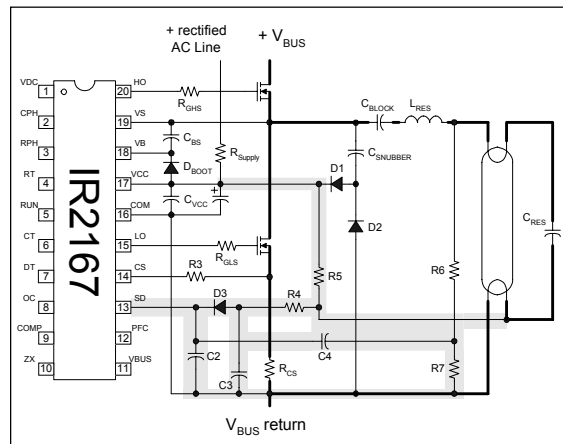

Figure 17: Lamp presence detection circuit connection (shaded area)

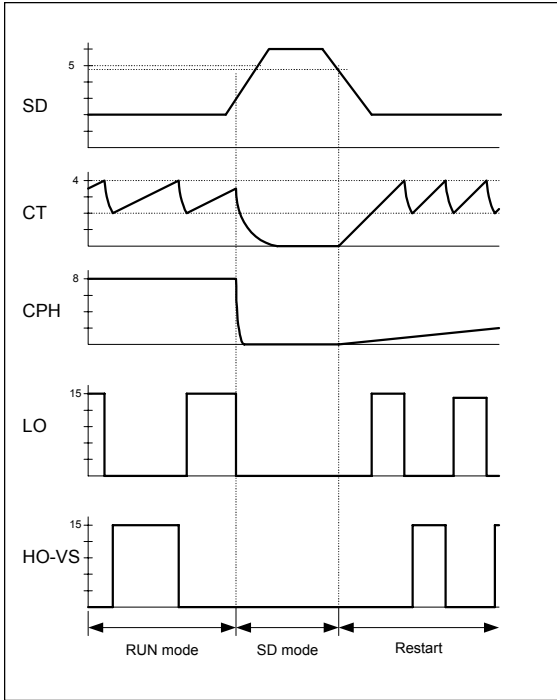

Figure 18: SD lead fault and auto restart

Half-Bridge Current Sensing and Protection

The third pin used for protection is the CS pin, which is normally connected to a resistor in the source of the lower power MOSFET, as shown in Figure 19. The CS pin is used to sense fault conditions such as failure of a lamp to strike, over-current during normal operation, hard switching, no load, and operation below resonance. If any one of these conditions is sensed, the fault latch is set, the oscillator is disabled, the gate driver outputs go low, and the chip is put into the micropower mode. The CS lead performs its sensing functions on a cycle-by-cycle basis in order to maximize ballast reliability.

For the over-current, failure-to-strike, and hard switching fault conditions, an externally programmable, positive-going CS+ threshold is enabled at the end of the preheat time. The level of this positive-going threshold is determined by the value of the resistor R_{OC} . The value of the resistor R_{OC} is determined by the following formula:

$$R_{OC} = \frac{V_{CS+}}{55E-6}, \text{ or}$$

$$V_{CS+} = 55E-6 \cdot R_{OC}$$

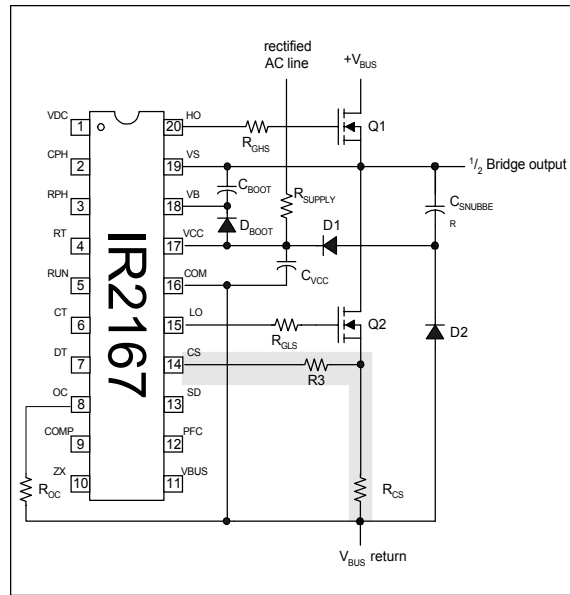

Figure 19: Half-bridge current sensing circuit connection (shaded area)

For the under-current and under-resonance conditions, there is a negative-going CS- threshold of 0.2V which is enabled at the onset of the run mode. The sensing of this CS- threshold is synchronized with the falling edge of the LO output.

Figures 20, 21 and 22 are oscillographs of fault conditions. Figure 20 shows a failure of the lamp to strike, Figure 21 shows a hard switching condition and Figure 22 shows an under-current condition.