



Chipsmall Limited consists of a professional team with an average of over 10 year of expertise in the distribution of electronic components. Based in Hongkong, we have already established firm and mutual-benefit business relationships with customers from,Europe,America and south Asia,supplying obsolete and hard-to-find components to meet their specific needs.

With the principle of "Quality Parts,Customers Priority,Honest Operation,and Considerate Service",our business mainly focus on the distribution of electronic components. Line cards we deal with include Microchip,ALPS,ROHM,Xilinx,Pulse,ON,Everlight and Freescale. Main products comprise IC,Modules,Potentiometer,IC Socket,Relay,Connector.Our parts cover such applications as commercial,industrial, and automotives areas.

We are looking forward to setting up business relationship with you and hope to provide you with the best service and solution. Let us make a better world for our industry!



Contact us

Tel: +86-755-8981 8866 Fax: +86-755-8427 6832

Email & Skype: info@chipsmall.com Web: www.chipsmall.com

Address: A1208, Overseas Decoration Building, #122 Zhenhua RD., Futian, Shenzhen, China



IR22771S/IR21771S(PbF)

Phase Current Sensor IC for AC motor control

Features

- Floating channel up to 600V for IR21771 and 1200V for IR22771
- Synchronous sampling measurement system
- High PWM noise (ripple) rejection capability
- Digital PWM output
- Fast Over Current detection
- Suitable for bootstrap power supplies
- Low sensing latency (<7.5 μ sec @20kHz)

Product Summary

V_{OFFSET} (max)	IR22771	1200 V
	IR21771	600V
V_{in} range		± 250 mV
Bootstrap supply range		8-20 V
Floating channel quiescent current (max)		2.2 mA
Sensing latency (max)		7.5 μ sec (@20kHz)
Throughput		40ksample/sec (@20kHz)
Over Current threshold (max)		± 470 mV

Description

IR21771/IR22771 is a high voltage, high speed, single phase current sensor interface for AC motor drive applications. The current is sensed by an external shunt resistor. The IC converts the analog voltage into a time interval through a precise circuit that also performs a very good ripple rejection showing small group delay. The time interval is level shifted and given to the output. The max throughput is 40 ksample/sec suitable for up to 20 kHz asymmetrical PWM modulation and max delay is <7.5 μ sec (@20kHz). Also a fast over current signal is provided for IGBT protection.

Package

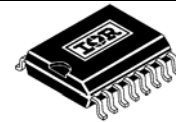

16-Lead SOIC
(wide body)

Typical Connection

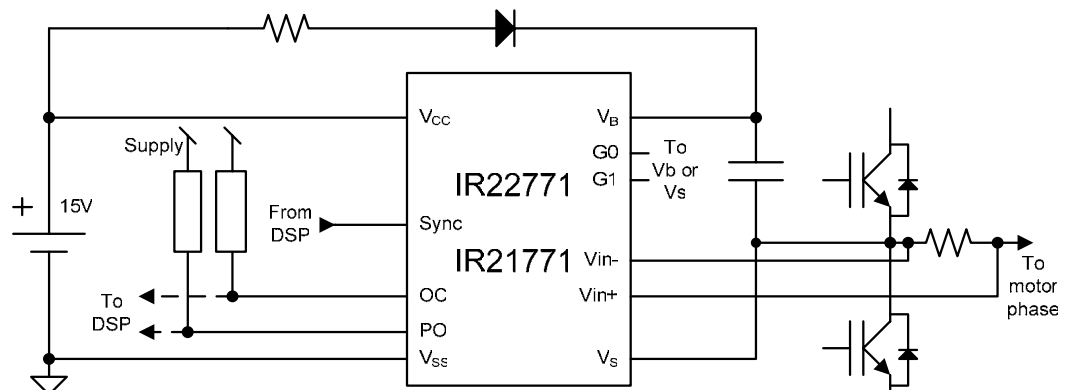

(Please refer to Lead Assignments for correct pin configuration. This diagram shows electrical connections only)

Absolute Maximum Ratings

Absolute Maximum Ratings indicate sustained limits beyond which damage to the device may occur. All voltage parameters are absolute voltages referenced to V_{SS} ; all currents are defined positive into any lead. The Thermal Resistance and Power Dissipation ratings are measured under board mounted and still air conditions.

Symbol	Definition		Min.	Max.	Units
V_B	High Side Floating Supply Voltage	IR22771	- 0.3	1225	V
		IR21771	- 0.3	625	V
V_S	High Side Floating Ground Voltage		$V_B - 25$	$V_B + 0.3$	V
V_{in+} / V_{in-}	High-Side Inputs Voltages		$V_B - 5$	$V_B + 0.3$	V
G0 / G1	High-Side Range Selectors		$V_B - 0.3$	$V_B + 0.3$	V
V_{CC}	Low-Side Fixed Supply Voltage		- 0.3	25	V
Sync	Low-Side Input Synchronization Signal		- 0.3	$V_{CC} + 0.3$	V
PO	PWM Output		- 0.3	$V_{CC} + 0.3$	V
OC	Over Current Output Voltage		- 0.3	$V_{CC} + 0.3$	V
dVS/dt	Allowable Offset Voltage Slew Rate			50	V/ns
P_D	Maximum Power Dissipation			250	mW
R_{thJA}	Thermal Resistance, Junction to Ambient			90	°C/W
T_J	Junction Temperature		-40	125	°C
T_S	Storage Temperature		-55	150	°C
T_L	Lead Temperature (Soldering, 10 seconds)			300	°C

Recommended Operating Conditions

For proper operation the device should be used within the recommended conditions. All voltage parameters are absolute voltages referenced to V_{SS} . The V_S offset rating is tested with all supplies biased at 15V differential.

Symbol	Definition		Min.	Max.	Units
V_{BS}	High Side Floating Supply Voltage ($V_B - V_S$)		$V_S + 8.0$	$V_S + 20$	V
V_S	High Side Floating Ground Voltage	IR22771	-5	1200	V
		IR21771	-5	600	V
V_{in+} / V_{in-}	High-Side Inputs Voltages		$V_S - 5.0$	$V_S + 5.0$	V
G0 / G1	High-Side Range Selectors		Note 1	Note1	
V_{CC}	Low Side Logic Fixed Supply Voltage		8	20	V
Sync	Low-Side Input Synchronization Signal		V_{SS}	V_{CC}	V
f_{sync}	Sync Input Frequency		4	20	kHz
PO	PWM Output		-0.3	Note 2	V
OC	Over Current Output Voltage		-0.3	Note 2	V
T_A	Ambient Temperature		-40	125	°C

Note 1: Shorted to V_S or V_B

Note 2: Pull-Up Resistor to V_{CC}

Static Electrical Characteristics

$V_{CC}, V_{BS} = 15V$ unless otherwise specified. Temp= $27^{\circ}C$; $V_{in}=V_{in+} - V_{in-}$.

Pin: V_{CC}, V_{SS}, V_B, V_S

Symbol	Definition	Min	Typ	Max	Units	Test Conditions
I_{QBS}	Quiescent V_{BS} supply current		1	2.2	mA	$f_{sync} = 10kHz, 20kHz$
I_{QCC}	Quiescent V_{CC} supply current			6	mA	$f_{sync} = 10kHz, 20kHz$
I_{LK}	Offset supply leakage current	IR22771		50	μA	$V_B = V_S = 1200V$
		IR21771		50	μA	$V_B = V_S = 600V$

Pin: $V_{in+}, V_{in-}, Sync, G0, G1, OC$

Symbol	Definition	Min	Typ	Max	Units	Test Conditions
V_{inmax}	Maximum input voltage before saturation		250		mV	
V_{inmin}	Minimum input voltage before saturation		-250		mV	
V_{IH}	Sync Input High threshold	2.2			V	See Figure 1
V_{IL}	Sync Input Low threshold			0.8	V	See Figure 1
V_{hy}	Sync Input Hysteresis	0.2			V	See Figure 1
I_{vinp}	V_{in+} input current	-18		-6	μA	$f_{sync} = 4kHz$ to $20kHz$
I_{pu}	G0, G1 pull-up Current	-20		-8	μA	$G1, G0 = V_B - 5V$
$ V_{octh} $	Over Current Activation Threshold	300		470	mV	
R_{Sync}	SYNC to V_{SS} internal pull-down	6		12	$k\Omega$	
R_{onOC}	Over Current On Resistance	25		75	Ω	@ $I = 2mA$ See Figure 3

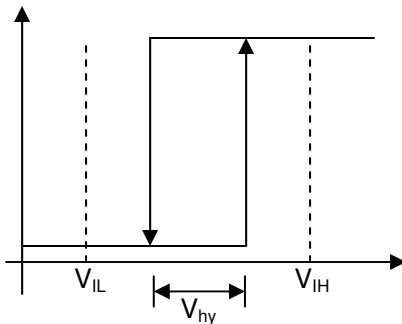

Figure 1: Sync input thresholds

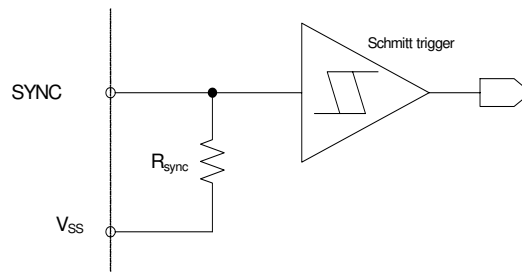

Figure 2: Sync input circuit

Pin: PO

Symbol	Definition	Min	Typ	Max	Units	Test Conditions
V_{POs}	Input offset voltage measured by PWM output	-50		20	mV	$R_{pull-up}=500\ \Omega$ $f_{sync} = 4, 20kHz$ $V_{threshold}=2.75V$ Ext supply=5V (See Figure 6)
$\Delta V_{POs} / \Delta T_j$	Input offset voltage temperature drift		TBD		$\mu V/^{\circ}C$	
ΔV_{POs}	Δ offset between samples on channel1 and channel2 measured at PO (See Note1)	-10		10	mV	$f_{sync} = 10kHz$ See Figure 6
G_p	PWM Output Gain	-38	-40.5	-42.5	%/V	$V_{in}=\pm 250mV$
$\Delta G_p / \Delta T_j$	PWM Output Gain Temperature Drift		TBD		%/($V \cdot ^{\circ}C$)	
CMRR PO	PO Output common mode (V_s) rejection		0.2		m%/V	$V_s - V_{SS} = 0, 600V$ $f_{sync} = 10kHz$
V_{Polin}	PO Linearity		0.07	0.2	%	$f_{sync} = 10kHz$
$\Delta V_{lin} / \Delta T_j$	PO Linearity Temperature Drift		TBD		%/ $^{\circ}C$	$f_{sync} = 10kHz$
V_{thPO}	PO threshold for OC reset	0.8		1.6	V	OC active (See Figure 4)
PSRR PO	PSRR for PO Output			0.2	%/V	$V_{CC}=V_{BS}= 8,20V$
R_{onPO}	PO On Resistance	25		75	Ω	@ $I = 2mA$ See Figure 3

Note1: Refer to PO output description for channels definition

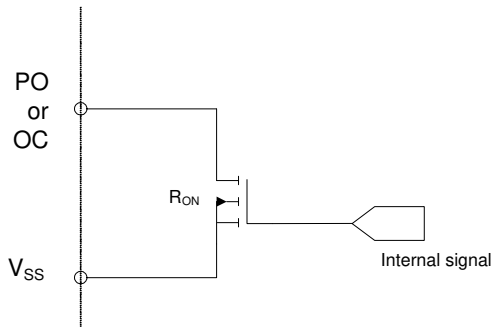

Figure 3: PO and OC open collector circuit

AC Electrical Characteristics

$V_{BIAS} (V_{CC}, V_{BS}) = 15V$ unless otherwise specified. Temp=27°C.

Symbol	Definition	Min	Typ	Max	Units	Test Conditions
f_{sync}	PWM frequency	4		20	kHz	
f_{out}	Throughput		$2 \cdot f_{sync}$		ksample/sec	
BW	Bandwidth (@ -3 dB)		f_{sync}		kHz	
GD	Group Delay (input filter)		$\frac{1}{4 \cdot f_{sync}}$		μs	
D_{min}	Minimum Duty Cycle (Note 1)		10		%	$V_{in}=+V_{inmax}$
D_{max}	Maximum Duty Cycle (Note 1)		30		%	$V_{in}=-V_{inmin}$
t_{dOCcon}	De-bounce time of OC	2.7	3.5	4.7	μs	See Figure 4
T_{OCoff}	Time to reset OC forcing PO			0.5	μs	See Figure 4
MD	Measure Delay			$\frac{0.30}{2 \cdot f_{sync}}$	μs	
SR	Step response (max time to reach steady state)	$\frac{0.51}{f_{sync}}$		$\frac{1.3}{f_{sync}}$	μs	See Figure 5

Note 1: negative logic, see fig. 4 on page 7

Note 2: Load < 5 nF avoids overshoot

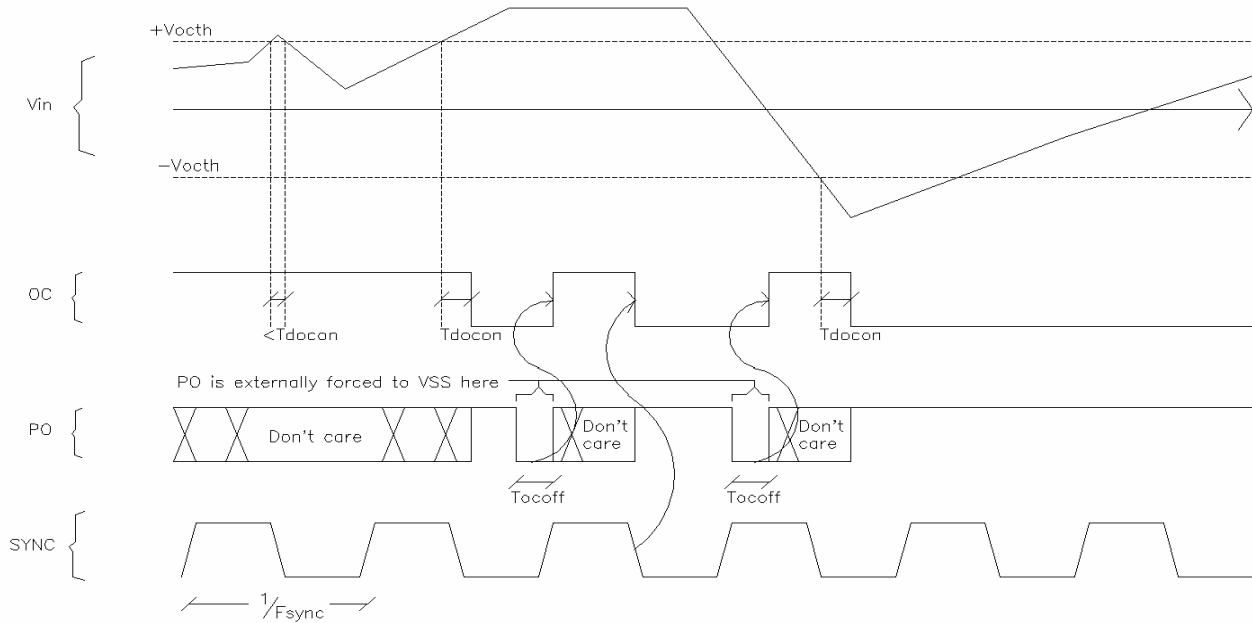

Figure 4: OC timing diagram

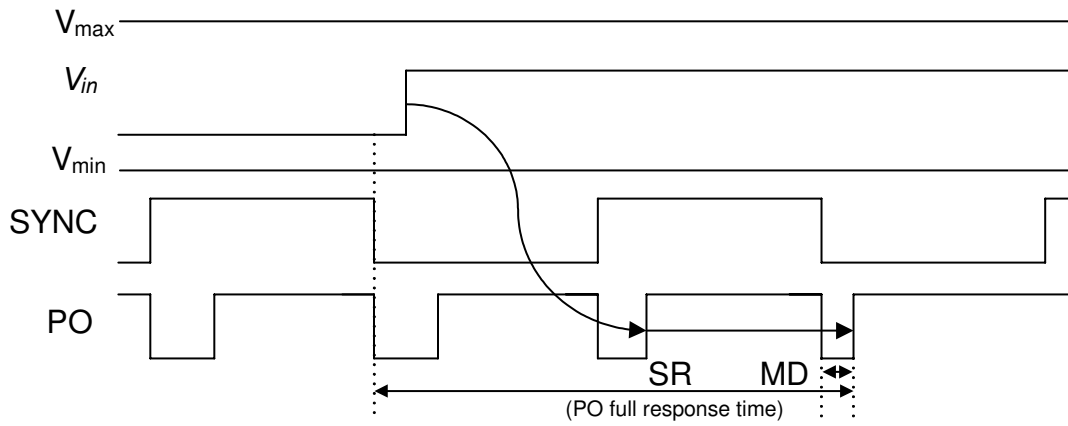

Figure 5: PO timing diagram

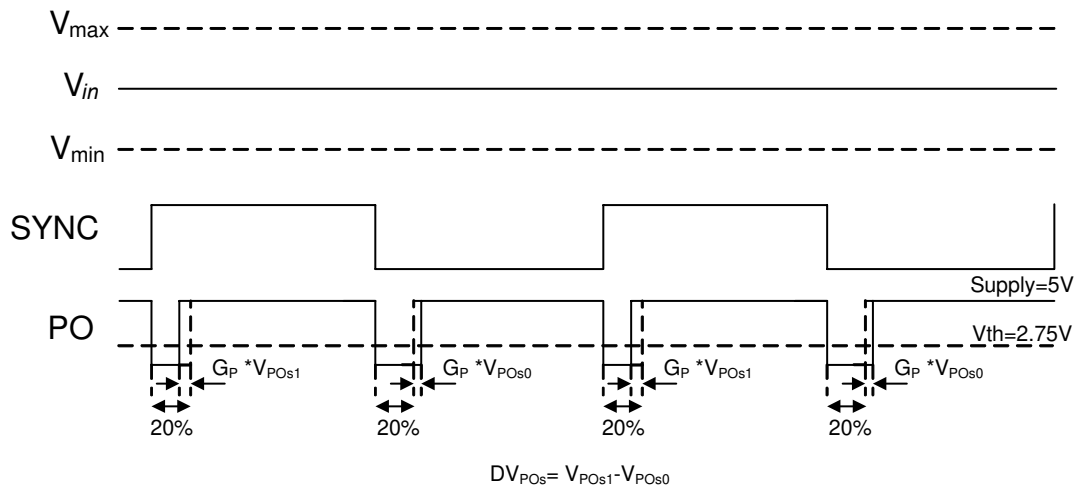
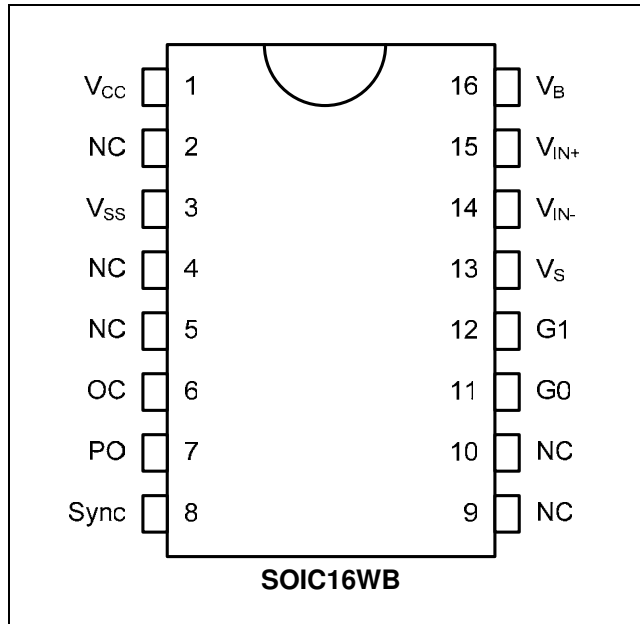

Figure 6: Δ offset between two consecutive samples measured at PO

Lead Assignments



Lead Definitions

Pin	Symbol	Description
1	V _{CC}	Low side voltage supply
2	NC	No connection
3	V _{SS}	Low side ground supply
4	NC	No connection
5	NC	No connection
6	OC	Over current signal (open drain)
7	PO	PWM output (open drain)
8	Sync	DSP synchronization signal
9	NC	No connection
10	NC	No connection
11	G0	Integrator gain lsb
12	G1	Integrator gain msb
13	V _S	High side return
14	V _{IN-}	Negative sense input
15	V _{IN+}	Positive sense input
16	V _B	High side supply

Timing and logic state diagrams description

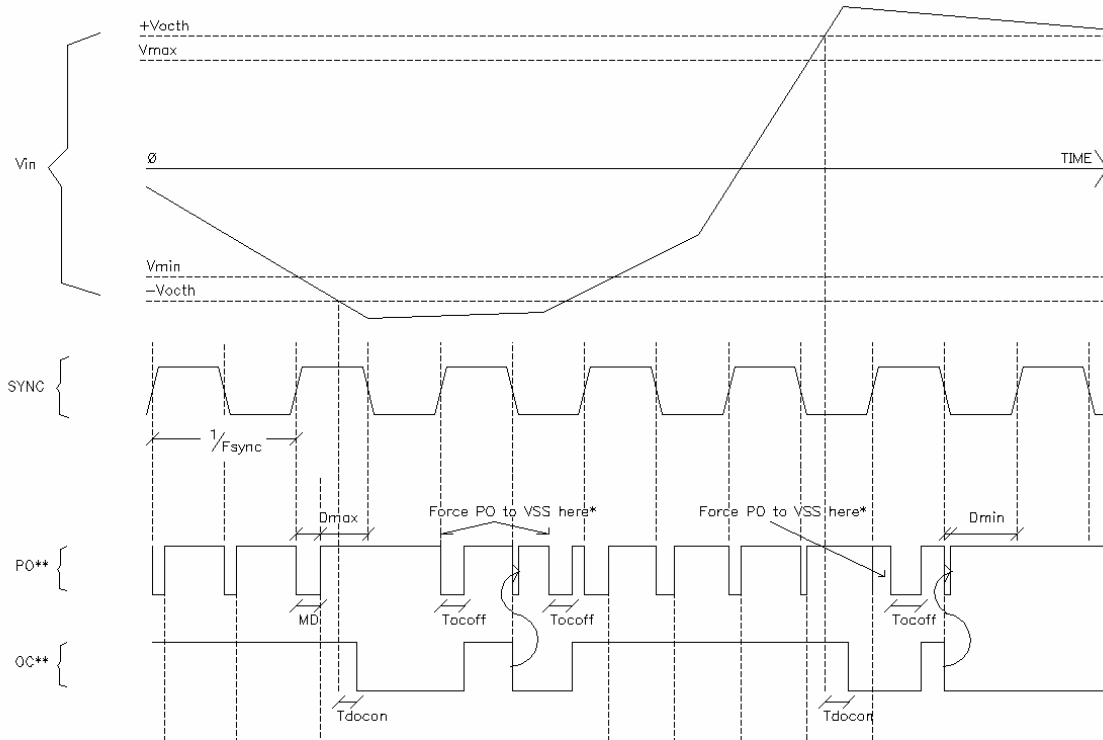

** See OC and PO detailed descriptions below in this document

Functional block diagram

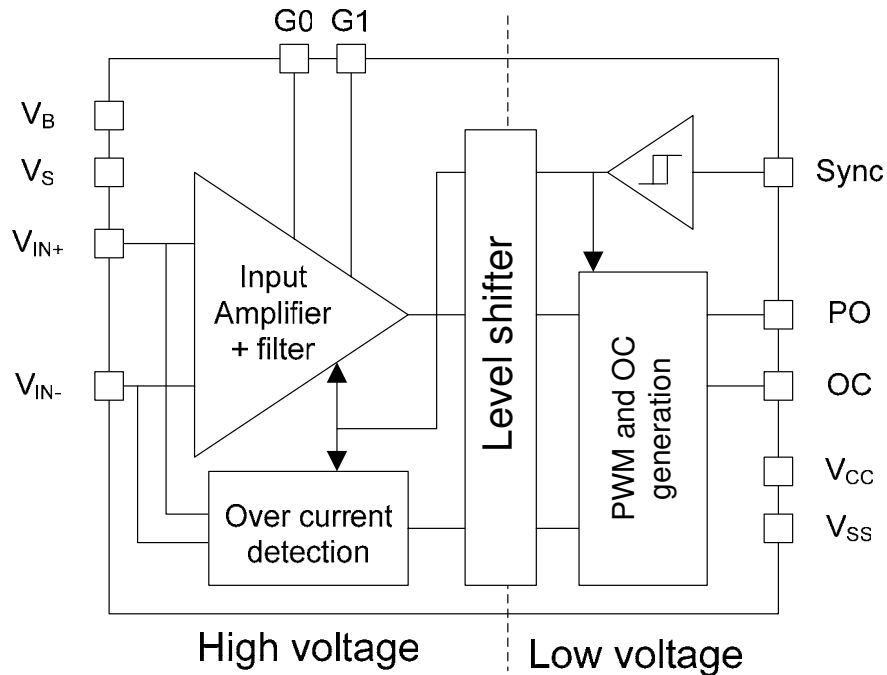

1 DEVICE DESCRIPTION

1.1 SYNC input

Sync input clocks the whole device. In order to make the device work properly it must be synchronous with the triangular PWM carrier as shown in Figure 8.

SYNC pin is internally pulled-down (10 kΩ) to V_{SS}.

1.2 PWM Output (PO)

PWM output is an open collector output (active low). It must be pulled-up to proper supply with an external resistor (suggested value between 500Ω and 10kΩ).

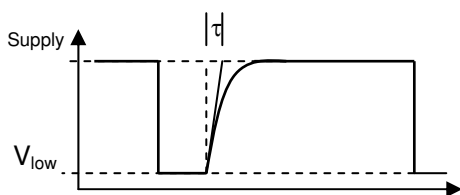

Figure 7: PO rising and falling slopes

PO pull-up resistor determines the rising slope of the PO output and the lower value of PO as shown in Figure 7, where $\tau = RC$, C is the total PO pin capacitance and R is the pull-up resistance.

$$V_{low} = Supply \cdot \frac{R_{on}}{R_{on} + R_{pull-up}}$$

where R_{on} is the internal open collector resistance and $R_{pull-up}$ is the external pull-up resistance.

PO duty cycle is defined for active low logic by the following formula:

$$\text{Eq. 1} \quad D_n = \frac{T_{off_cycle_n+1}}{T_{cycle_n}}$$

PO duty cycle (D_n) swings between 10% and 30%. Zero input voltage corresponds to 20% duty cycle.

IR22771S/IR21771S(PbF)

A residual offset can be read in PO duty cycle according to V_{POS} (see Static electrical characteristics).

According to Figure 8, it can be assumed that odd cycles are represented by SYNC at high level (channel 1) and even cycles represented by SYNC at low level (channel 2).

The two channels are independent in order to provide the correct duty cycle value of PO even for non-50% duty cycle of SYNC signal. Small variation of SYNC duty cycle are then allowed and automatically corrected when calculating the duty cycle using Eq. 1.

However, channel 1 and channel 2 can have a difference in offset value which is specified in ΔV_{POS} (see Static electrical characteristics).

To implement a correct offset compensation of PO duty cycle, each channel must be compensated separately.

1.3 Over Current output (OC)

OC output is an open drain pin (active low).

A simplified block diagram of the over current circuit is shown in the Figure 9.

Over current is detected when $|V_{in}| = |V_{inp} - V_{inm}| > V_{OCth}$. If an event of over current lasts longer than t_{dOCOn} , OC pin is forced to V_{SS} and remains latched until PO is externally forced low for at least t_{OCoff} (see timing on Figure 4). During an over current event (OC is low), PO is off (pulled-up by external resistor).

If OC is reset by PO and over current is still active, OC pin will be forced low again by the next edge of SYNC signal.

To reset OC state PO must be forced to V_{SS} for at least T_{OCoff} .

- Auto reset function

The auto reset function consists in clearing automatically the OC fault.

To enable the auto reset function, simply short circuit the OC pin with the PO pin.

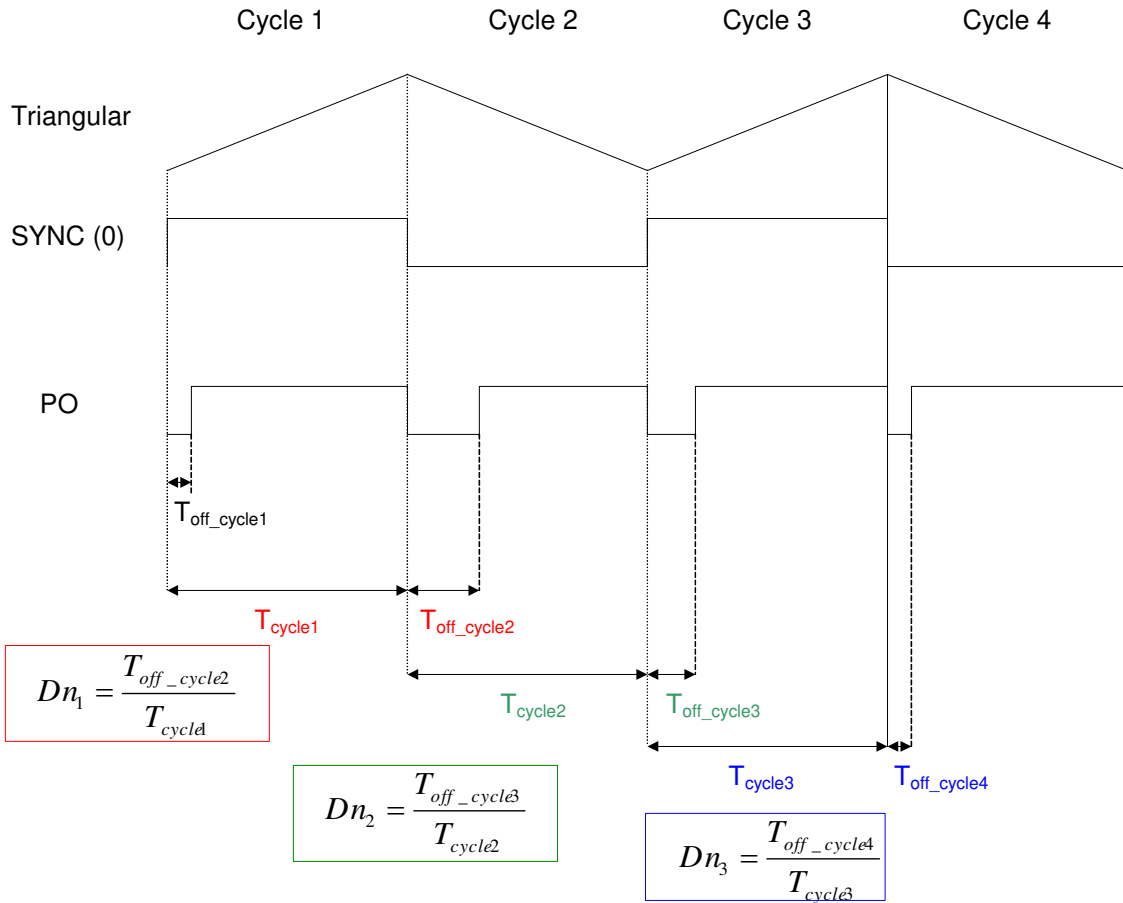

Figure 8: PO Duty Cycle

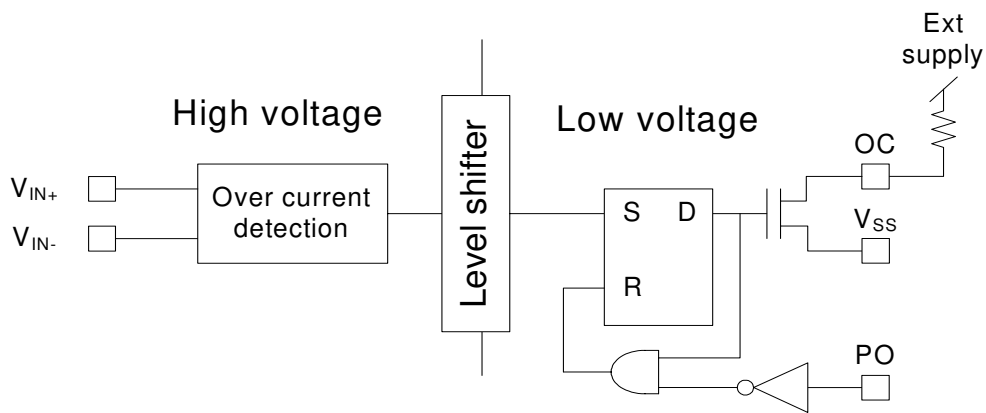

Figure 9: Over current block diagram

1.4 DC transfer functions

The working principle of the device can be easily explained by Figure 10, in which the main signals are represented.

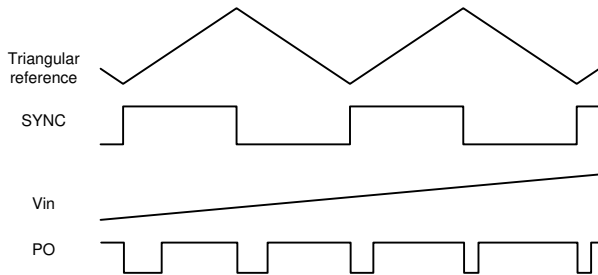

Figure 10: Main current sensor signals and outputs

PWM out (PO pin) gives a duty cycle which is inversely proportional to the input signal. Eq. 2 gives the resulting D_n of the PWM output (PO pin):

$$\text{Eq. 2 } D_n = 20\% - 40 \frac{\%}{V} \cdot V_{in}$$

where $V_{in} = V_{inp} - V_{inm}$

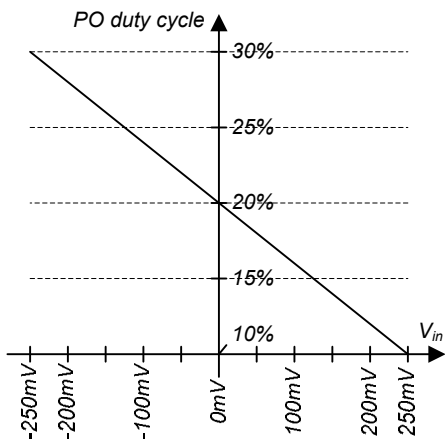

Figure 11: PO Duty Cycle (D_n)

IR22771S/IR21771S(PbF)

1.5 Filter AC characteristic

IR21771/22771 signal path can be considered as composed by three stages in series (see Figure 13). The first two stages perform the filtering action. Stage 1 (input filter) implements the filtering action originating the transfer function shown in Figure 14. The input filter is a self-adaptive reset integrator which performs an accurate ripple cancellation. This stage extracts automatically the PWM frequency from Sync signal and puts transmission zeros at even harmonics, rejecting the unwanted PWM noise.

The following timing diagram shows the principle by which even harmonics are rejected (Figure 12).

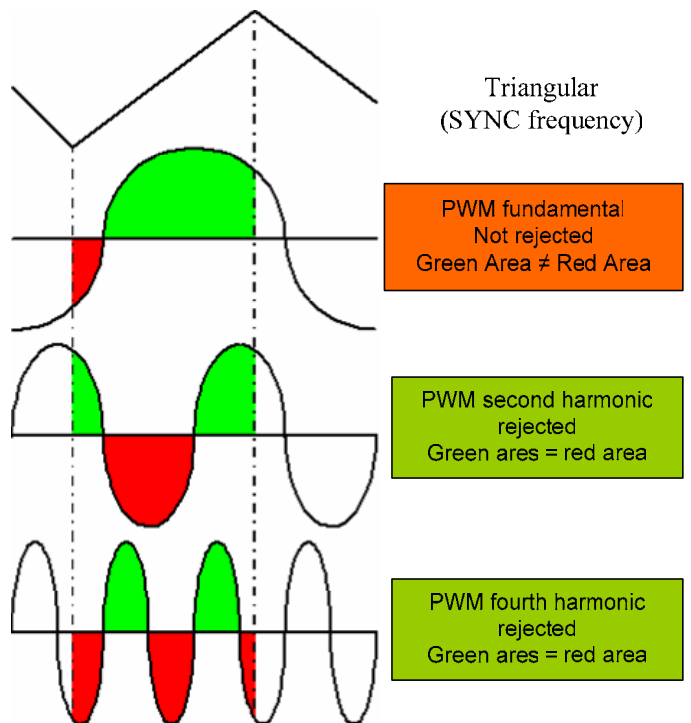

Figure 12: Even harmonic cancellation principle

As can be seen from Figure 14, the odd harmonics are rejected as a first order low pass filter with a single pole placed in f_{PWM} . The input filter group delay in the pass-band is very low (see GD on AC electrical characteristics) due to the beneficial action of the zeroes.

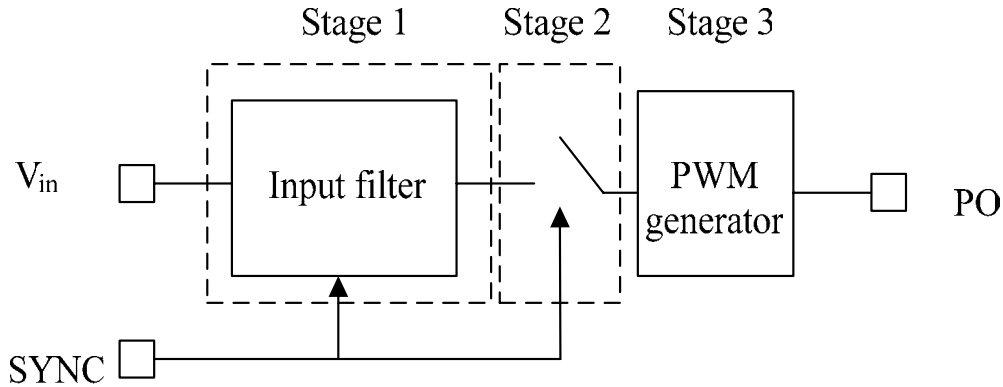

Figure 13: Simplified block diagram

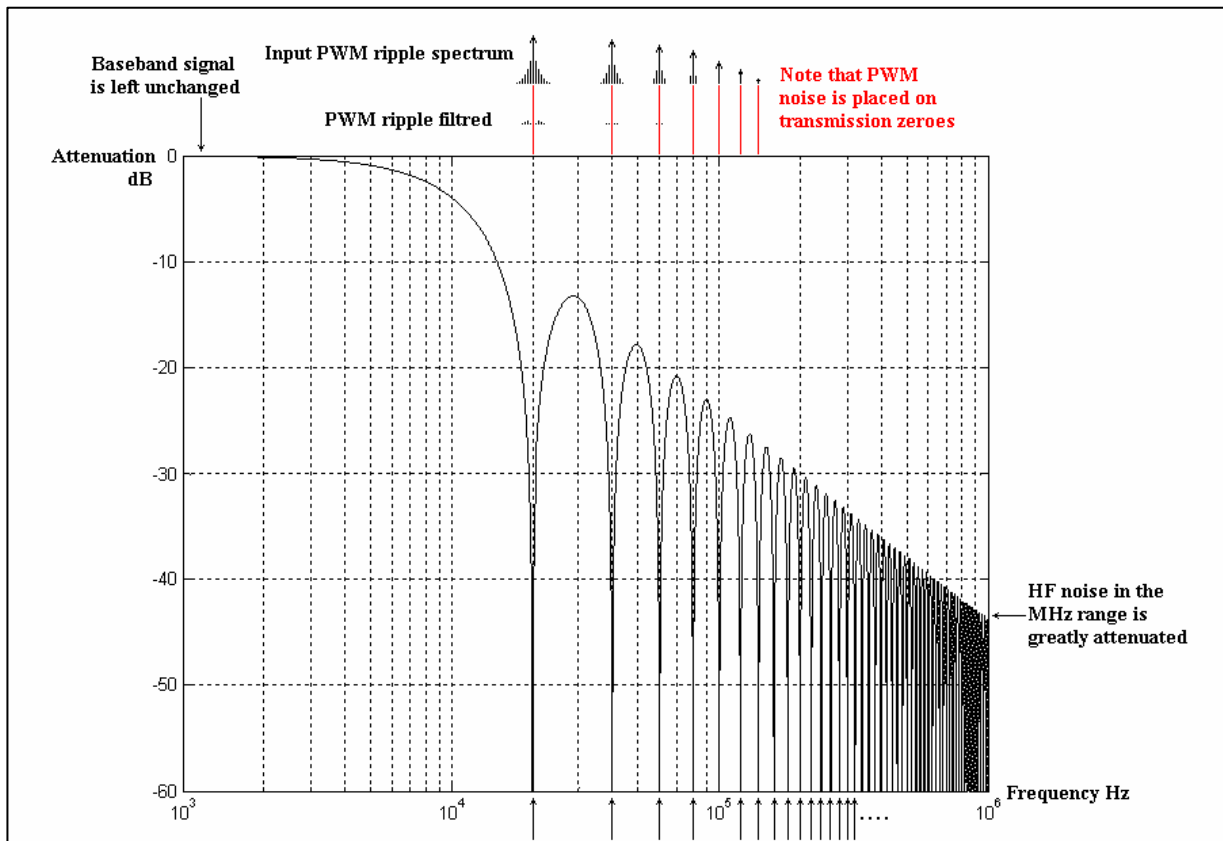

Figure 14: Input filter transfer function (10 kHz PWM)

The second stage samples the result of the first stage at double Sync frequency. This action can be used to fully remove the odd harmonics from the input signal.

To perform this cancellation it is necessary a shift of 90 degrees of the SYNC signal with respect to the triangular carrier edges (SYNC2).

The following timing diagrams show the principle of odd harmonics cancellation (Figure 15), in which SYNC2 allows the sampling of stage 1 output during odd harmonic zero crossings.

Odd harmonic cancellation using SYNC2 (i.e. 90 degrees shifted SYNC signal) signal will introduce $T_{sync}/4$ additional propagation delay.

Another way to obtain the same result (odd harmonics cancellation) can be achieved by controller computing the average of two consecutive PO results using SYNC1 (SYNC is in this case aligned to triangular edges, i.e. 0 degree shift). This method is suitable for most symmetric (center aligned) PWM schemes.

IR22771S/IR21771S(PbF)

For this particular PWM scheme another suitable solution is driving the IR2x771 with a half frequency SYNC signal ($f_{SYNC}=f_{PWM}/2$). In this case the cut frequency of the input filter is

reduced by half allowing zeroes to be put at f_{PWM} multiples (i.e. even and odd harmonics cancellation, no more computational effort needed by the controller).

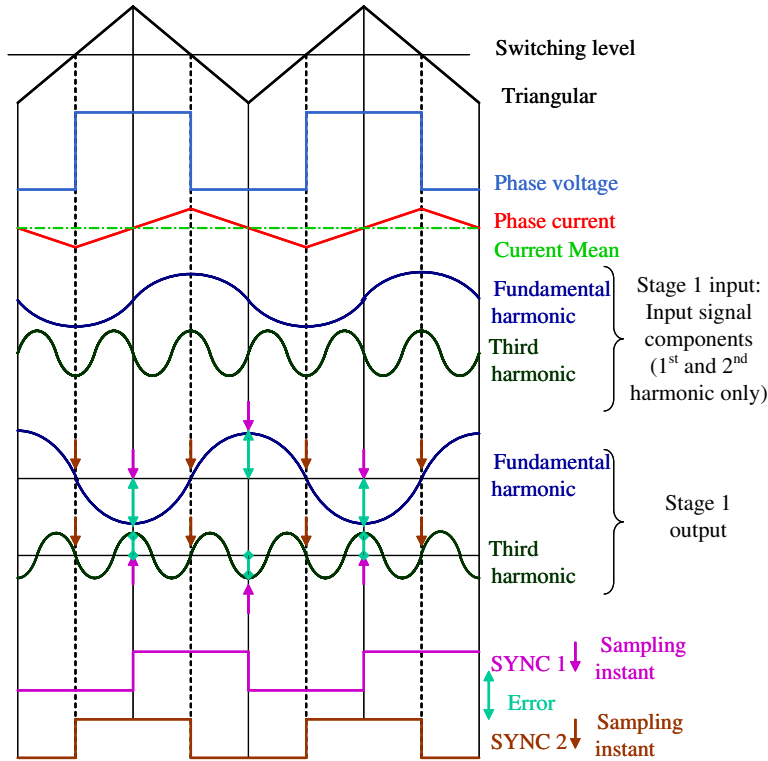

Figure 15: Even harmonic cancellation principle

1.6 Input filter gain setting

G0 and G1 pins are used to change the time constant of the integrators of the high side input filter.

To avoid internal saturation of the input filter, G0 and G1 must be connected according to SYNC frequency as shown in Table 1. A too small time constant may saturate the internal integrator, while a large time constant may reduce accuracy.

G0 and G1 do not affect the overall current sensor gain.

f_{PWM}	G0	G1
> 16 kHz *	V_B	V_B
16 / 10 kHz	V_S	V_B
10 / 6 kHz	V_B	V_S
< 6 kHz	V_S	V_S

* → 40 kHz

Table 1: G0, G1 gain settings

2 Sizing tips

2.1 Bootstrap supply

The $V_{BS1,2,3}$ voltage provides the supply to the high side drivers circuitry of the IR22771S/IR21771S. V_{BS} supply sit on top of the V_S voltage and so it must be floating.

The bootstrap method to generate V_{BS} supply can be used with IR22771S/IR21771S current sensors. The bootstrap supply is formed by a diode and a capacitor connected as in Figure 16.

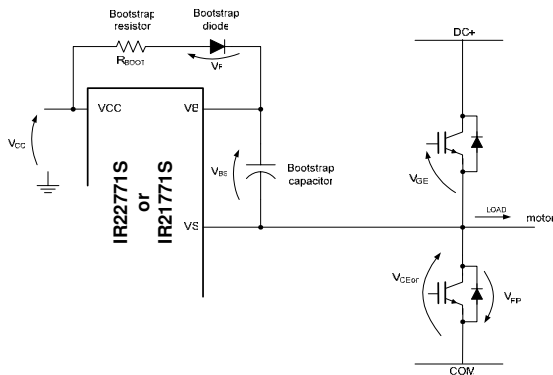

Figure 16: bootstrap supply schematic

This method has the advantage of being simple and low cost but may force some limitations on duty-cycle and on-time since they are limited by the requirement to refresh the charge in the bootstrap capacitor.

Proper capacitor choice can reduce drastically these limitations.

Bootstrap capacitor sizing

Given the maximum admitted voltage drop for V_{BS} , namely ΔV_{BS} , the influencing factors contributing to V_{BS} decrease are:

- Floating section quiescent current (I_{QBS});
- Floating section leakage current (I_{LK});
- Bootstrap diode leakage current (I_{LK_DIODE});
- Charge required by the internal level shifters (Q_{LS}); typical 20nC
- Bootstrap capacitor leakage current (I_{LK_CAP});
- High side on time (T_{HON}).

I_{LK_CAP} is only relevant when using an electrolytic capacitor and can be ignored if other types of capacitors are used. It is strongly recommend using at least one low ESR ceramic capacitor (paralleling electrolytic and low ESR ceramic may result in an efficient solution).

IR22771S/IR21771S(PbF)

Then we have:

$$Q_{TOT} = Q_{LS} + (I_{QBS} + I_{LK} + I_{LK_DIODE} + I_{LK_CAP}) \cdot T_{HON}$$

The minimum size of bootstrap capacitor is then:

$$C_{BOOT\ min} = \frac{Q_{TOT}}{\Delta V_{BS}}$$

Some important considerations

a) Voltage ripple

There are three different cases making the bootstrap circuit get conductive (see Figure 16)

- $I_{LOAD} < 0$; the load current flows in the low side IGBT displaying relevant V_{CEon}

$$V_{BS} = V_{CC} - V_F - V_{CEon}$$

In this case we have the lowest value for V_{BS} . This represents the worst case for the bootstrap capacitor sizing. When the IGBT is turned off the V_S node is pushed up by the load current until the high side freewheeling diode get forward biased

- $I_{LOAD} = 0$; the IGBT is not loaded while being on and V_{CE} can be neglected

$$V_{BS} = V_{CC} - V_F$$

- $I_{LOAD} > 0$; the load current flows through the freewheeling diode

$$V_{BS} = V_{CC} - V_F + V_{FP}$$

In this case we have the highest value for V_{BS} . Turning on the high side IGBT, I_{LOAD} flows into it and V_S is pulled up.

b) Bootstrap Resistor

A resistor (R_{boot}) is placed in series with bootstrap diode (see Figure 16) so to limit the current when the bootstrap capacitor is initially charged. We suggest not exceeding some Ohms (typically 5, maximum 10 Ohm) to avoid increasing the V_{BS} time-constant. The minimum on time for charging the bootstrap capacitor or for refreshing its charge must be verified against this time-constant.

c) Bootstrap Capacitor

For high T_{HON} designs where is used an electrolytic tank capacitor, its ESR must be considered. This parasitic resistance develops a voltage divider with R_{boot} generating a voltage step on V_{BS} at the first charge of bootstrap capacitor. The voltage step and the related speed (dV_{BS}/dt) should be limited. As a general rule, ESR should meet the following constraint:

$$\frac{ESR}{ESR + R_{BOOT}} \cdot V_{CC} \leq 3V$$

Parallel combination of small ceramic and large electrolytic capacitors is normally the best compromise, the first acting as fast charge tank for the gate charge only and limiting the dV_{BS}/dt by reducing the equivalent resistance while the second keeps the V_{BS} voltage drop inside the desired ΔV_{BS} .

d) Bootstrap Diode

The diode must have a $BV > 600V$ (or $1200V$ depending on application) and a fast recovery time ($t_{rr} < 100 ns$) to minimize the amount of charge fed back from the bootstrap capacitor to V_{CC} supply.

3 PCB LAYOUT TIPS

3.1 Distance from H to L voltage

The IR22771S/IR21771S package (wide body) maximizes the distance between floating (from DC- to DC+) and low voltage pins (V_{SS}). It's strongly recommended to place components tied to floating voltage in the respective high voltage portions of the device (V_B, V_S) side.

3.2 Ground plane

Ground plane must NOT be placed under or nearby the high voltage floating side to minimize noise coupling.

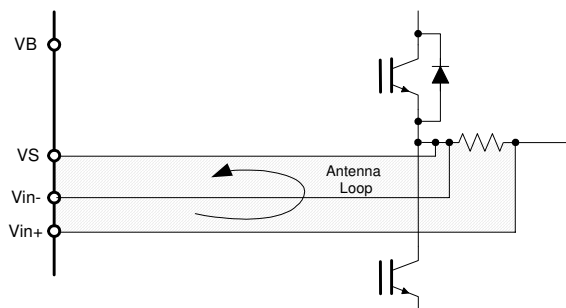

Figure 17: antenna loops

3.3 Antenna loops and inputs connection

Current loops behave like antennas able to receive EM noise. In order to reduce EM coupling, loops must be reduced as much as possible. Figure 17 shows the high side shunt loops.

Moreover it is strongly suggested to use Kelvin connections for V_{in+} and V_{in-} to shunt paths and star-connect V_S to V_{in-} close to the shunt resistor as explained in Fig. 18.

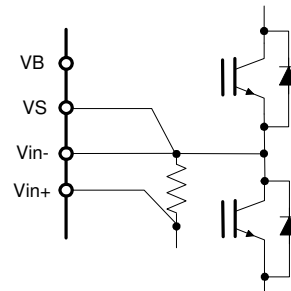

Figure 18: Recommended shunt connection

3.4 Supply capacitors

The supply capacitors must be placed as close as possible to the device pins (V_{CC} and V_{SS} for the ground tied supply, V_B and V_S for the floating supply) in order to minimize parasitic traces inductance/resistance.

