



Chipsmall Limited consists of a professional team with an average of over 10 year of expertise in the distribution of electronic components. Based in Hongkong, we have already established firm and mutual-benefit business relationships with customers from,Europe,America and south Asia,supplying obsolete and hard-to-find components to meet their specific needs.

With the principle of “Quality Parts,Customers Priority,Honest Operation,and Considerate Service”,our business mainly focus on the distribution of electronic components. Line cards we deal with include Microchip,ALPS,ROHM,Xilinx,Pulse,ON,Everlight and Freescale. Main products comprise IC,Modules,Potentiometer,IC Socket,Relay,Connector.Our parts cover such applications as commercial,industrial, and automotives areas.

We are looking forward to setting up business relationship with you and hope to provide you with the best service and solution. Let us make a better world for our industry!



Contact us

Tel: +86-755-8981 8866 Fax: +86-755-8427 6832

Email & Skype: info@chipsmall.com Web: www.chipsmall.com

Address: A1208, Overseas Decoration Building, #122 Zhenhua RD., Futian, Shenzhen, China



PROGRAMMABLE CURRENT SENSE HIGH SIDE SWITCH

Features

- Load current feedback
- Programmable over current shutdown
- Active clamp
- ESD protection
- Input referenced to Vcc
- Over temperature shutdown
- Reverse battery protection

Description

The IR3313(S)PbF is a fully protected 4 terminals high side switch. The input signal is referenced to Vcc. When the input voltage $V_{cc} - V_{in}$ is higher than the specified threshold, the output Mosfet is turned on. When the $V_{cc} - V_{in}$ is lower than the specified V_{il} threshold, the output Mosfet is turned off. A current proportional to the power Mosfet current is sourced to the Ifb pin. Over current shutdown occurs when $V_{st} - V_{in} > 4.5V$. The current shutdown threshold is adjusted by selecting the proper R_{lfb} . Either over current and over temperature latches off the switch. The device is reset by pulling the input pin high. Other integrated protections (ESD, reverse battery, active clamp) make the switch very rugged in automotive environment.

Typical Connection

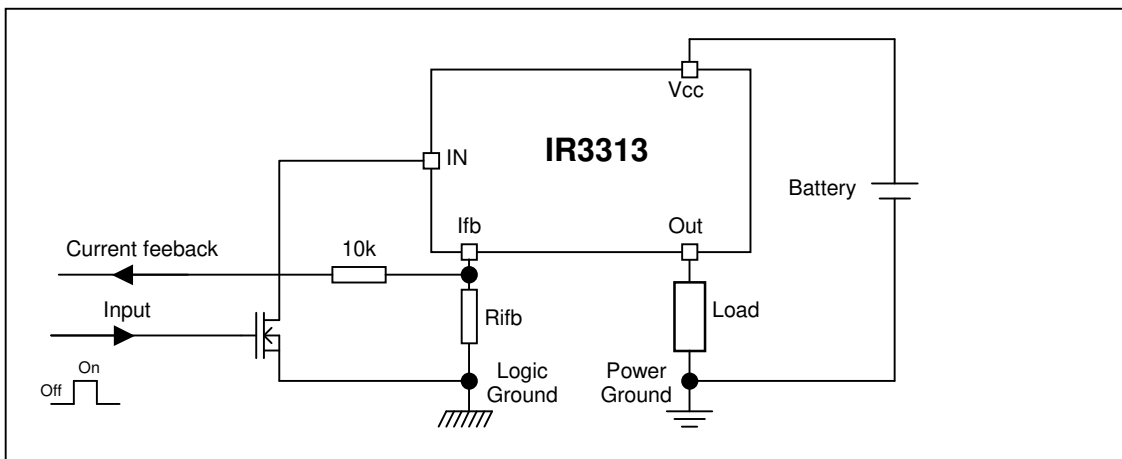

Product Summary

R _{ds(on)}	7 mΩ max.
V _{cc op.}	6 to 32V
Current Ratio	8800
Prog. I _{shutdown}	10 to 90A
V _{clamp}	40V

Packages



TO-220
IR3313



D²Pak
Pin 4 and 5 fused
IR3313S

Absolute Maximum Ratings

Absolute maximum ratings indicate sustained limits beyond which damage to the device may occur. All voltage parameters are referenced to Vcc lead. (Tambient=25°C unless otherwise specified).

Symbol	Parameter	Min.	Max.	Units
Vcc-Vin	Maximum Vcc voltage	-16	37	V
Vcc-Vin cont.	Maximum continuous Vcc voltage	-16	32	
Vcc-Vfb	Maximum lfb voltage	-16	33	
Vcc-Vout	Maximum output voltage	-0.3	37	
I _{ds} cont.	Maximum body diode continuous current Rth=60°C/W (1)	—	2.8	A
I _{ds} pulsed	Maximum body diode pulsed current (1)	—	100	
Pd	Maximum power dissipation Rth=60°C/W	—	2	W
ESD1	Electrostatic discharge voltage (Human body) C=100pF, R=1500Ω	—	4	kV
ESD2	Electrostatic discharge voltage (Machine Model) C=200pF,R=0Ω	—	0.5	
Tj max.	Max. storage & operating temperature junction temperature	-40	150	°C
Min Rfb	Minimum on the resistor on lfb pin	0.3	—	kΩ
I _{fb} max.	Max. lfb current	-50	50	mA

(1) Limited by junction temperature. Pulsed is also limited by wiring

Thermal Characteristics

Symbol	Parameter	Typ.	Max.	Units
Rth1	Thermal resistance junction to ambient D ² -Pak Std footprint	60	—	°C/W
Rth2	Thermal resistance junction to case D ² -Pak	0.7	—	
Rth2	Thermal resistance junction to case TO220	0.7	—	

Recommended Operating Conditions

These values are given for a quick design. For operation outside these conditions, please consult the application notes.

Symbol	Parameter	Min.	Max.	Units
I _{out}	Continuous output current	—	23	A
	T _{ambient} =85°C, Rth=5°C/W, Tj=125°C			
	T _{ambient} =85°C, Rth=60°C/W, Tj=125°C			
R _{fb}	Recommended lfb resistor (2)(3)	0.3	3.5	kΩ
Pulse min.	Minimum turn-on pulse width	1	—	ms
F _{max}	Maximum operating frequency	—	200	Hz

2) If R_{fb} is too low, the device can be damaged.

3) If R_{fb} is too high, the device may not switch on.

Protection Characteristics

T_j=25°C, R_{ifb}=500 to 3.5kΩ

Symbol	Parameter	Min.	Typ.	Max.	Units	Test Conditions
V _{ifb-Vin@I_{sd}}	Over-current shutdown threshold	4	4.7	5.6	V	
T _{sd}	Over temperature threshold	—	165	—	°C	See fig. 5
OV	Over voltage protection (not latched)	33	35	39	V	
I _{sd} f	Fixed over current shutdown	90	120	140	A	V _{ifb} <V _{ifb-Vin@I_{sd}}
I _{sd} _1k	Programmable over current shutdown 1k	30	40	50		R _{ifb} =1kΩ
T _{reset}	Time to reset protection	—	50	500	μs	See fig. 5
Min. pulse	Min. pulse width (no WAIT state)	200	400	1200		
WAIT	WAIT function timer	0.4	1	2	ms	See fig. 4 and 5
R _{ds(on)} rev.	Reverse battery On state resistance	4	6.7	10	mΩ	V _{cc-Vin} =-14V, I _{out} =30A

Static Electrical Characteristics

T_j=25°C, V_{cc}=14V (unless otherwise specified)

Symbol	Parameter	Min.	Typ.	Max.	Units	Test Conditions
V _{cc op.}	Operating Voltage range	6	—	32	V	
I _{cc off}	Supply leakage current	—	1.5	5	μA	V _{in} =V _{cc} , V _{cc-Vout} =14V, V _{cc-Vifb} =14V
I _{in, on}	On state I _N positive current	1.5	3	6	mA	V _{cc-Vin} =14V
V _{ih}	High level Input threshold voltage (4)	—	5.4	6.2	V	
V _{il}	Low level Input threshold voltage (4)	4	4.9	5.8		
V _{hyst}	Input hysteresis V _{ih} -V _{il}	0.2	0.4	1	μA	
I _{out}	Drain to source leakage current	—	1.2	5		V _{in} =V _{cc} , V _{cc-Vifb} =0V, V _{cc-Vout} =14V
R _{ds(on)}	On state resistance (5) T _j =25°C	4	5.5	7	mΩ	I _{out} =30A, V _{cc-Vin} =14V
	On state resistance (5) T _j =25°C	4	6	10		I _{out} =17A, V _{cc-Vin} =6V
	On state resistance (5)(6) T _j =150°C	7	10.5	13.5		I _{out} =30A, V _{cc-Vin} =14V
V _{clamp1}	V _{cc} to V _{out} clamp voltage 1	36	39	—	V	I _{out} =50mA
V _{clamp2}	V _{cc} to V _{out} clamp voltage 2	—	40	43	V	I _{out} =30A

(4) Input thresholds are measured directly between the input pin and the tab. Any parasitic resistance in common between the load current path and the input signal path can significantly affect the thresholds.

(5) R_{ds(on)} is measured between the tab and the Out pin, 5mm away from the package.

(6) Guaranteed by design

Switching Electrical Characteristics

V_{cc}=14V, Resistive load=0.5Ω, T_j=25°C

Symbol	Parameter	Min.	Typ.	Max.	Units	Test Conditions
T _{don}	Turn on delay time to 10% V _{cc}	8	32	80	μs	See figure 2
T _{r1}	Rise time to V _{cc-Vout} =5V	3	16	40		
T _{r2}	Rise time to V _{cc-Vout} =0.1V _{cc}	10	40	100		
E _{on}	Turn on energy	—	4.5	—	mJ	
T _{doff}	Turn off delay time	20	80	200	μs	
T _f	Fall time to V _{out} =10% of V _{cc}	8	32	80		
E _{off}	Turn off energy	—	2	—	mJ	

Current Sense Characteristics

Symbol	Parameter	Min.	Typ.	Max.	Units	Test Conditions
Ratio	I Load/I _{fb} current ratio	7,500	8,800	9,950	—	T _j =25°C, R _{fb} =500Ω, I _{out} =60A
Ratio_TC	I Load/I _{fb} variation aver temperature(6)	-5	—	+5	%	T _j =-40°C to 150°C
Offset	I Load current diagnostic offset	-0.22	0	+0.2	A	I _{out} =2A
Trst	I _{fb} response time (low signal)	—	1	—	μs	90% of the I _{out} step

Functional Block Diagram

All values are typical

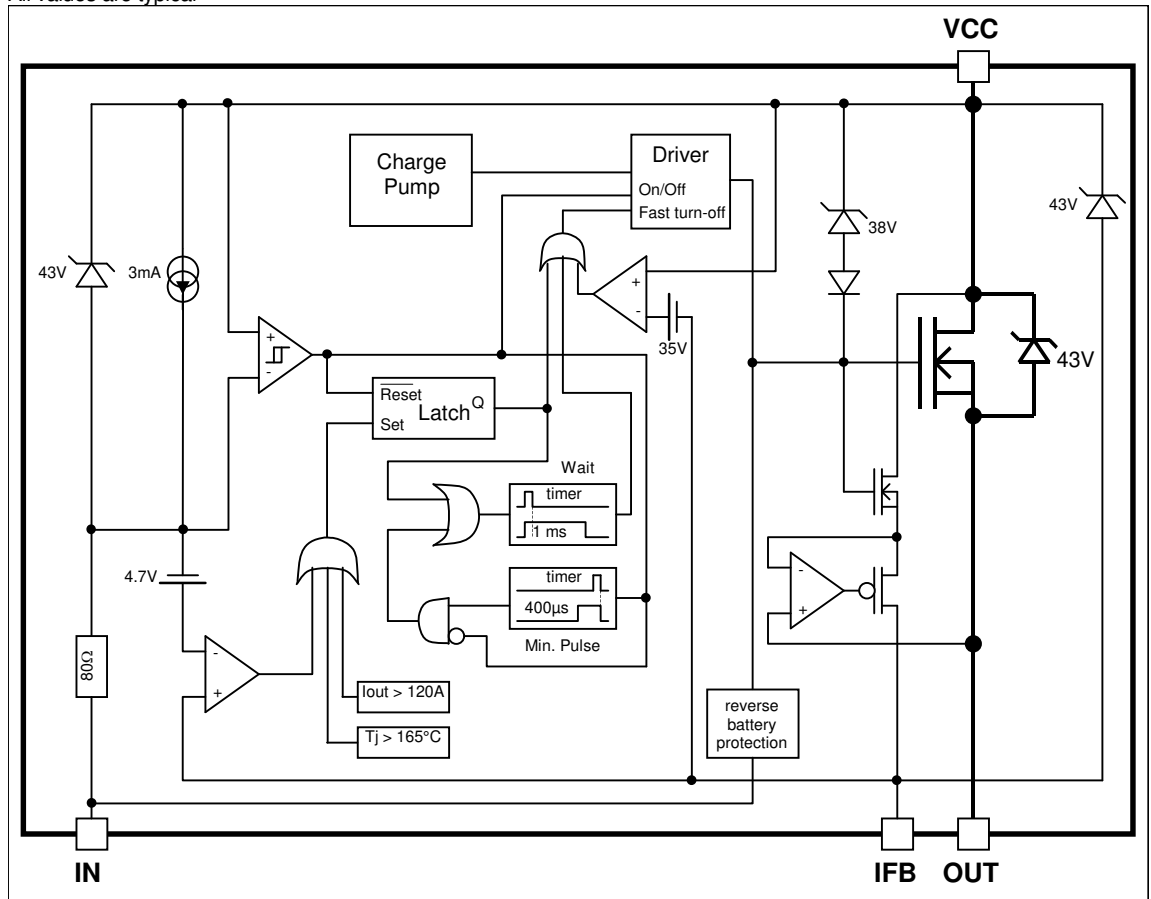

Lead Assignments

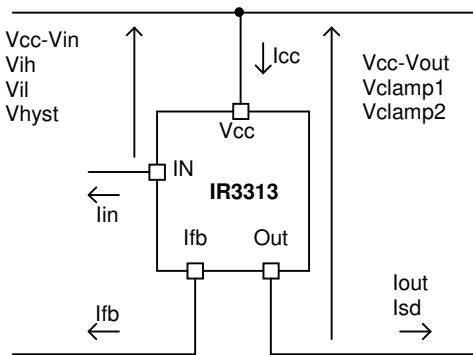
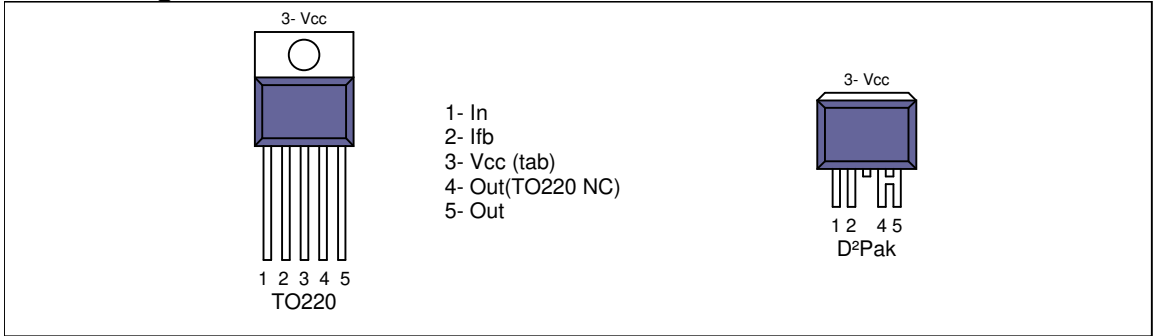

Figure 1 – Voltages and current definitions

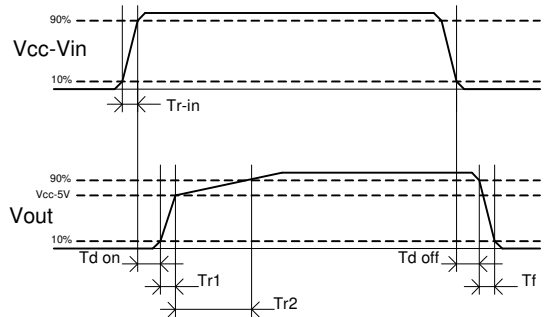

Figure 2 – Switching time definitions

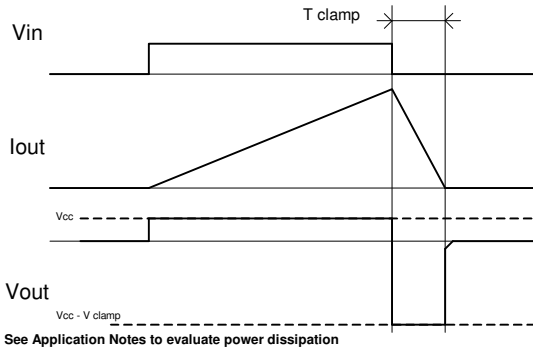

Figure 3 – Active clamp waveforms

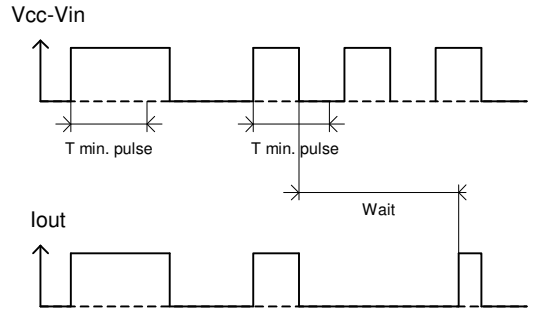

Figure 4 – Min. pulse and Wait function

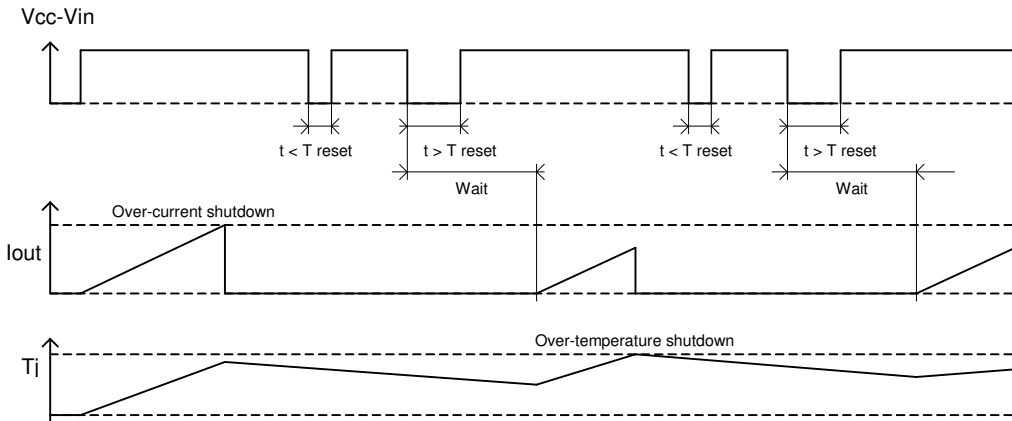

Figure 5 – Protection Timing Diagrams

All curves are typical characteristics. Operation in hatched areas is not recommended. $T_j=25^\circ\text{C}$, $R_{\text{th}}=500\text{ohm}$, $V_{\text{cc}}=14\text{V}$ (unless otherwise specified).

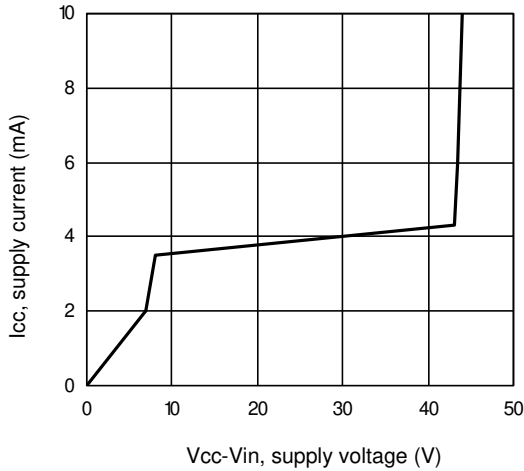

Figure 6 – Icc (mA) Vs Vcc-Vin (V)

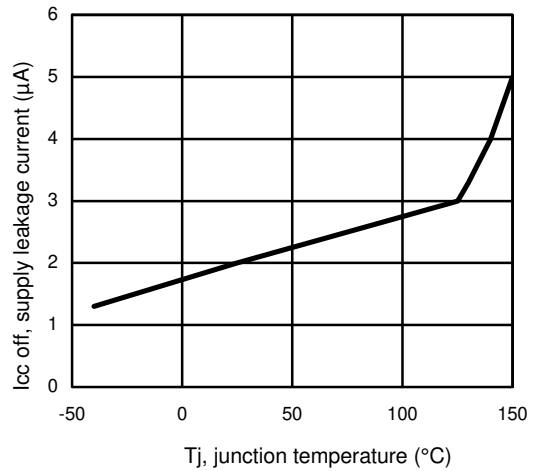

Figure 7 – Icc off (µA) Vs Tj (°C)

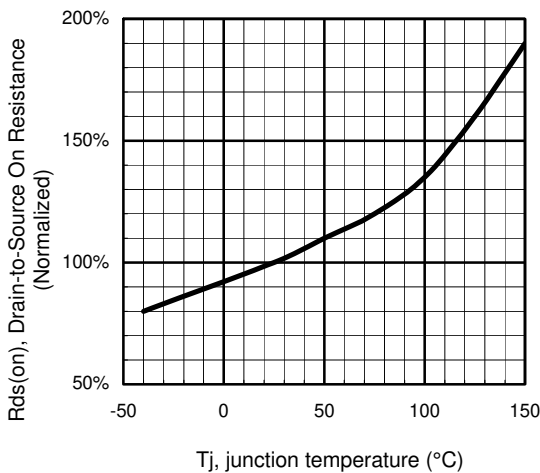

Figure 8 - Normalized Rds(on) (%) Vs Tj (°C)

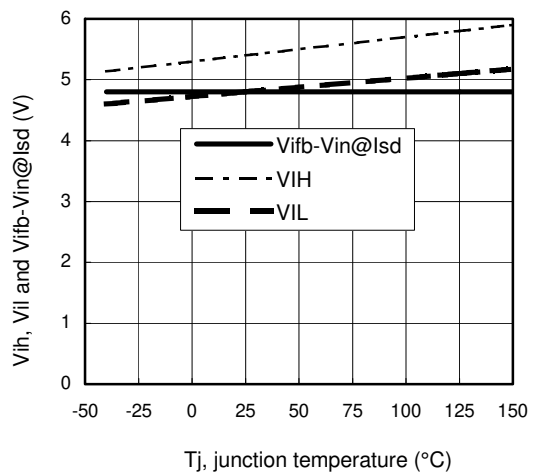

Figure 9 – Vih, Vil and Vfb-Vin@Istd (V) Vs Tj (°C)

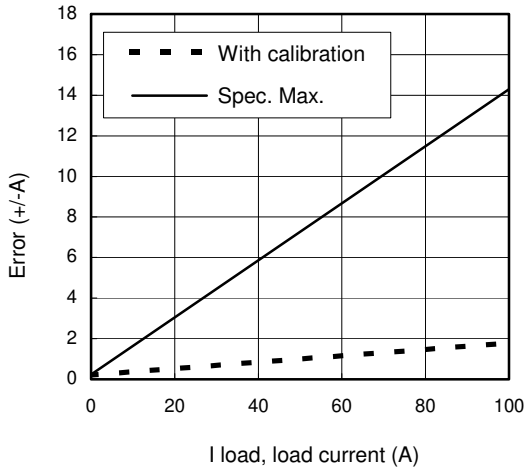

Figure 10 – Error (+/- A) Vs I load (A)

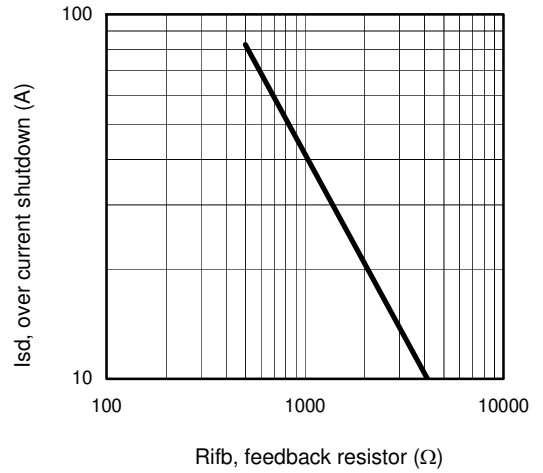

Figure 11 – Ids (A) Vs Rifb (Ω)

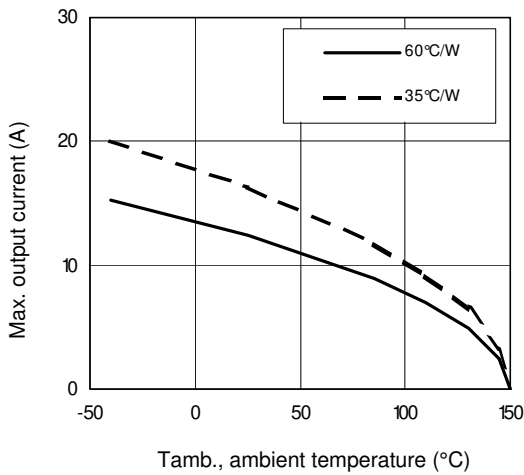

Figure 12 – Max. iout (A) Vs Tamb. (°C)

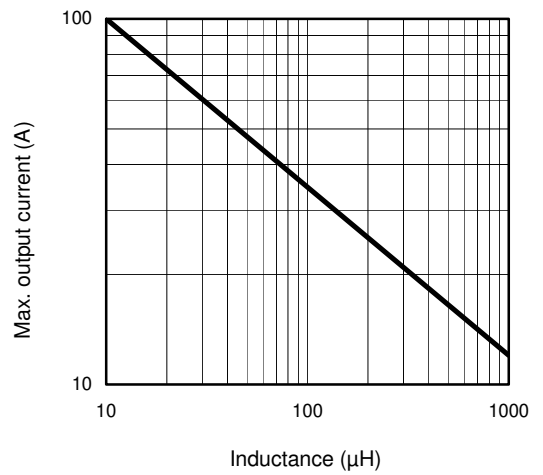

Figure 13 – Max. iout (A) Vs inductance (μH)

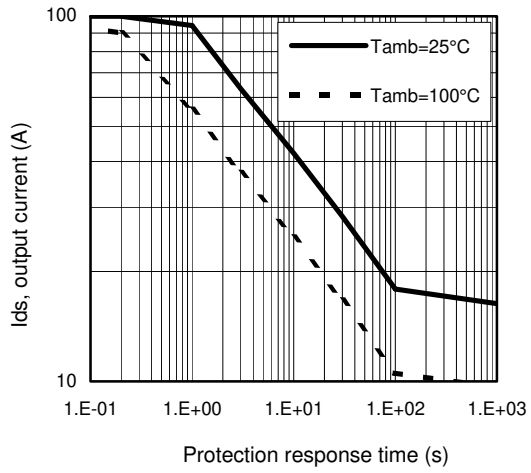

Figure 14 – I_{ds} (A) Vs over temperature protection response time (s)/ $R_{th}=60^{\circ}\text{C/W}$

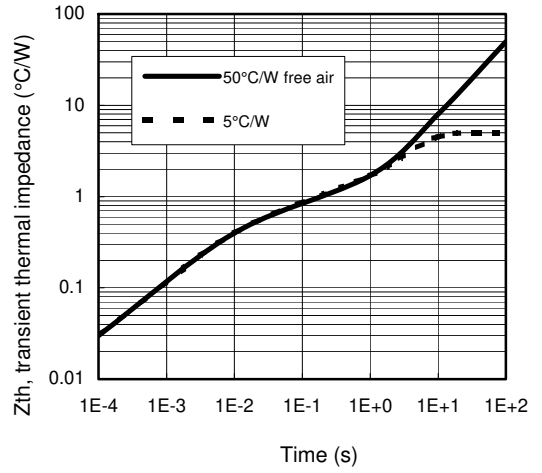
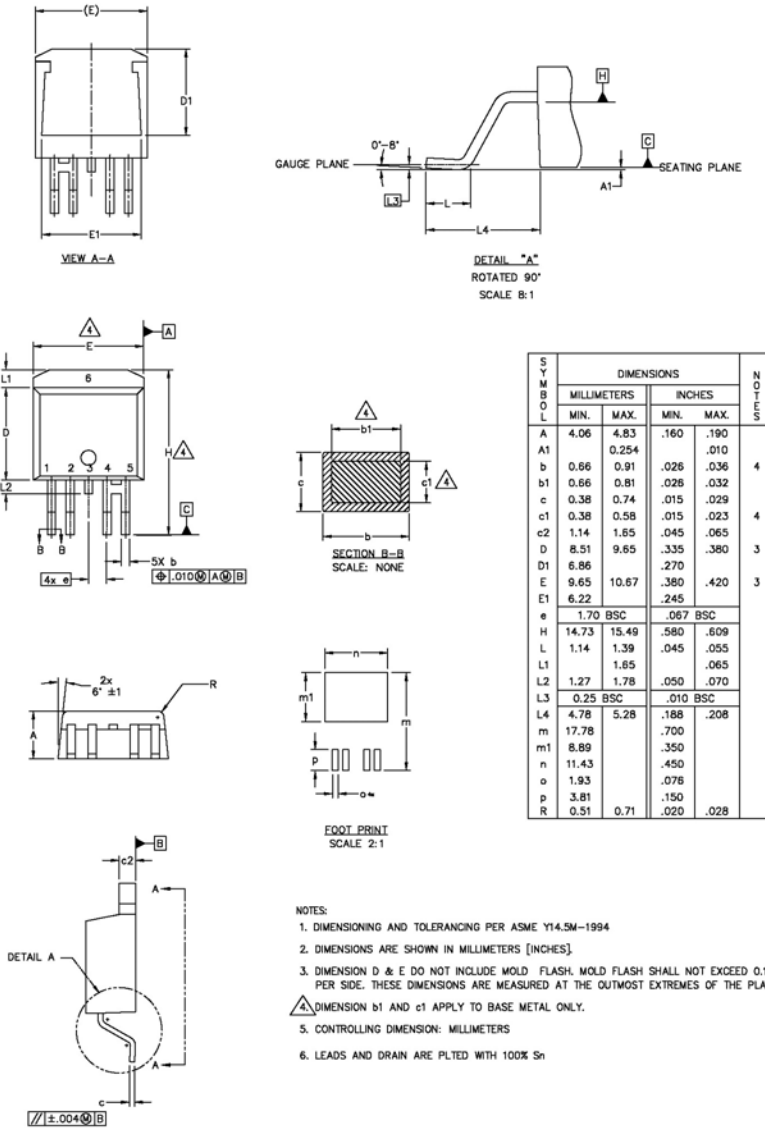
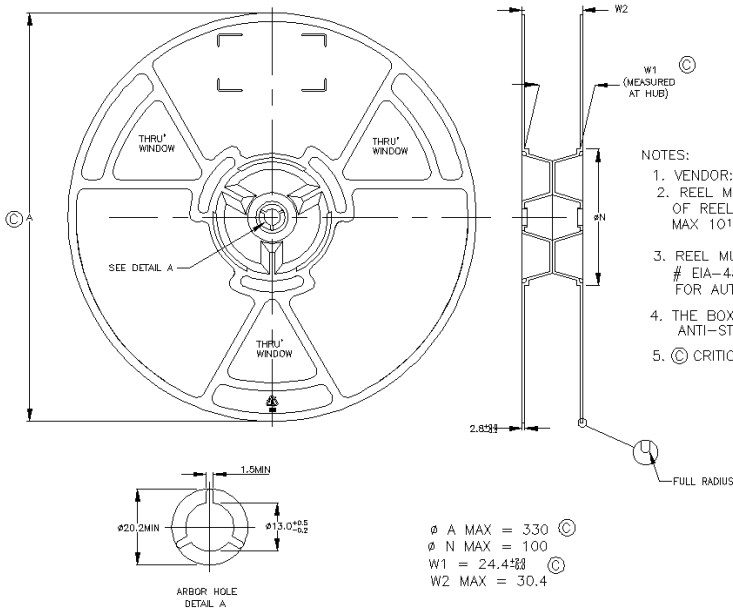

Figure 15 – Transient thermal impedance (°C/W) Vs time (s)

Case Outline 5 Leads - D2PAK – Automotive Q100 PbF MSL1 qualified



Tape & Reel 5 Lead - D2PAK (SMD220)



- NOTES:
1. VENDOR: OPTIONAL
 2. REEL MUST HAVE ANTI-STATIC COATING SURFACE RESISTIVITY OF REEL (AS PER EIA-541) min: 10⁹ ohm/SQUARE; MAX 10¹² ohm/SQUARE
 3. REEL MUST ALSO MEET REQUIREMENTS OF EIA STANDARD # EIA-481A, TAPING OF SURFACE-MOUNT COMPONENTS FOR AUTOMATIC PLACEMENT.
 4. THE BOX OF PACKING MUST CONTAIN THE REELS INSIDE AN ANTI-STATIC BAG.
 5. (C) CRITICAL

Case Outline 5 Leads – TO220 – Automotive Q100 PbF qualified

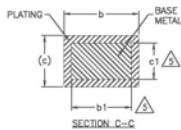
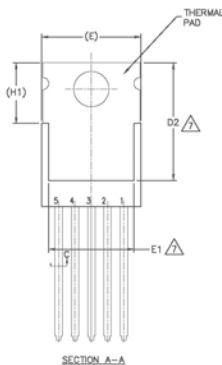
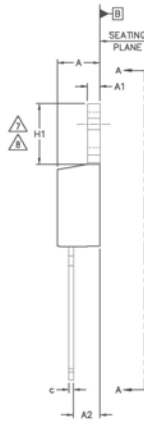
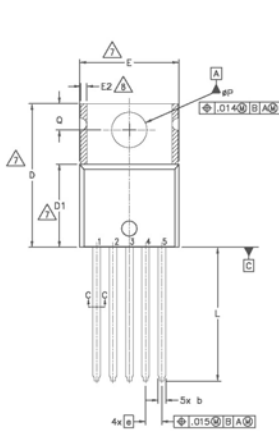

DIMENSION	DIMENSIONS				NOMINAL VALUE
	MILLIMETERS		INCHES		
	MIN.	MAX.	MIN.	MAX.	
A	3.56	4.83	.140	.190	
A1	0.51	1.40	.020	.055	
A2	2.03	2.92	.080	.115	
b	0.64	0.89	.025	.035	
bt	0.64	0.84	.025	.033	5
c	0.36	0.61	.014	.024	
c1	0.36	0.56	.014	.022	5
D	14.22	16.51	.560	.650	4
D1	6.36	9.02	.330	.355	
D2	11.68	12.88	.460	.507	7
E	9.65	10.67	.380	.420	4,7
E1	6.86	8.89	.270	.350	7
E2	-	0.76	-	.030	8
e	1.70 BSC		.067 BSC		
H1	5.84	6.86	.230	.270	7,8
L	12.70	14.73	.500	.580	
ϕP	3.53	3.73	.139	.147	
Q	2.54	3.05	.100	.120	

- NOTES:
- 1.- DIMENSIONING AND TOLERANCING AS PER ASME Y14.5 M-1994.
 - 2.- DIMENSIONS ARE SHOWN IN INCHES [MILLIMETERS].
 - 3.- LEAD DIMENSION AND FINISH UNCONTROLLED IN L1.
 - 4.- DIMENSION D1, D1 & E DO NOT INCLUDE MOLD FLASH. MOLD FLASH SHALL NOT EXCEED .005" (0.127) PER SIDE. THESE DIMENSIONS ARE MEASURED AT THE OUTERMOST EXTREMES OF THE PLASTIC BODY.
 - 5.- DIMENSION bt & c1 APPLY TO BASE METAL ONLY.
 - 6.- CONTROLLING DIMENSION - INCHES.
 - 7.- THERMAL PAD CONTOUR OPTIONAL WITHIN DIMENSIONS E,H1,D2 & E1.
 - 8.- DIMENSION E2 X H1 DEFINE A ZONE WHERE STAMPING AND SINGULATION IRREGULARITIES ARE ALLOWED.
 - 9.- OUTLINE CONFORMS TO JEDEC TO-220, EXCEPT A2 (max.) AND D2 (min.) WHERE DIMENSIONS ARE DERIVED FROM THE ACTUAL PACKAGE OUTLINE.
 - 10.- LEADS AND DRAIN ARE PLATED WITH 100% Sn