



Chipsmall Limited consists of a professional team with an average of over 10 year of expertise in the distribution of electronic components. Based in Hongkong, we have already established firm and mutual-benefit business relationships with customers from,Europe,America and south Asia,supplying obsolete and hard-to-find components to meet their specific needs.

With the principle of “Quality Parts,Customers Priority,Honest Operation,and Considerate Service”,our business mainly focus on the distribution of electronic components. Line cards we deal with include Microchip,ALPS,ROHM,Xilinx,Pulse,ON,Everlight and Freescale. Main products comprise IC,Modules,Potentiometer,IC Socket,Relay,Connector.Our parts cover such applications as commercial,industrial, and automotives areas.

We are looking forward to setting up business relationship with you and hope to provide you with the best service and solution. Let us make a better world for our industry!



## Contact us

Tel: +86-755-8981 8866 Fax: +86-755-8427 6832

Email & Skype: info@chipsmall.com Web: www.chipsmall.com

Address: A1208, Overseas Decoration Building, #122 Zhenhua RD., Futian, Shenzhen, China



## FEATURES

- Ultra Low Quiescent Power Dual output 4+1 phase PWM Controller
- Intel® VR12, VR12.5 & Memory VR modes
- Overclocking & Gaming Modes
- PVI GPU VR mode
- Switching frequency from 194KHz to 2MHz per phase in 56 steps
- IR Efficiency Shaping Features including Dynamic Phase Control and Automatic Power State Switching
- Programmable 1-phase or 2-phase operation for Light Loads and Active Diode Emulation for Very Light Loads
- IR Adaptive Transient Algorithm (ATA) on both loops minimizes output bulk capacitors and system cost
- Auto-Phase Detection with PID Coefficient auto-scaling
- Fault Protection: OVP, UVP, OCP, OTP, CAT FLT
- I2C/SMBus/PMBus system interface for reporting of Temperature, Voltage, Current & Power telemetry for both loops
- Multiple Time Programming (MTP) with integrated charge pump for easy non-volatile programming
- Compatible with 3.3V tri-state drivers and IR ATL mode drivers
- +3.3V supply voltage; -40°C to 85°C ambient operation
- Pb-Free, RoHS, 5x5mm 40-pin, 0.4mm pitch QFN

## APPLICATIONS

- Intel® VR12 and VR12.5 based systems
- Servers and High End Desktop CPU VRs
- High Performance Graphics Processors

## DESCRIPTION

The IR3584 is a dual-loop digital multi-phase buck controller designed for CPU voltage regulation, and is fully compliant with Intel® VR12 and compliant with VR12.5 Rev 1.3 PWM specifications.

The IR3584 includes IR's Efficiency Shaping Technology to deliver exceptional efficiency at minimum cost across the entire load range. IR's Dynamic Phase Control adds/drops phases based upon load current. The IR3584 can be configured to enter 1 or 2-phase operation and active diode emulation mode automatically or by command.

IR's unique Adaptive Transient Algorithm (ATA), based on proprietary non-linear digital PWM algorithms, minimizes output bulk capacitors.

IR3584 has 127 possible address values for both the PMBus and I2C bus interfaces. The device configuration can be easily defined using the IR Digital Power Design Center (DPDC) GUI, and is stored in the on-chip Non-Volatile Memory (NVM). This reduces external components and minimizes the package size.

The IR3584 provides extensive OVP, UVP, OCP, OTP & CAT FLT fault protection, and includes thermistor based temperature sensing or per phase temperature reporting when using the IR powIRstage. The controller is designed to work with either R<sub>ds(on)</sub> current sense PowIRstages or with DCR current sense.

The IR3584 also includes numerous VR design simplifying and differentiating features, like register diagnostics, which enable fast time-to-market.

## ORDERING INFORMATION

Base Part Number	Package Type	Standard Pack		Orderable Part Number
		Form	Quantity	
IR3584	40-pin, QFN 5 mm x 5 mm	Tape and Reel	3000	IR3584MxxyTRP <sup>1</sup>
IR3584	40-pin, QFN 5 mm x 5 mm	Tape and Reel	3000	IR3584MTRPBF
IR3584	40-pin, QFN 5 mm x 5 mm	Tray	4900	IR3584MTYPBF

### Notes:

1. Customer Specific Configuration File, where xx = Customer ID and yy = Configuration File (Codes assigned by IR Marketing).

**ORDERING INFORMATION**

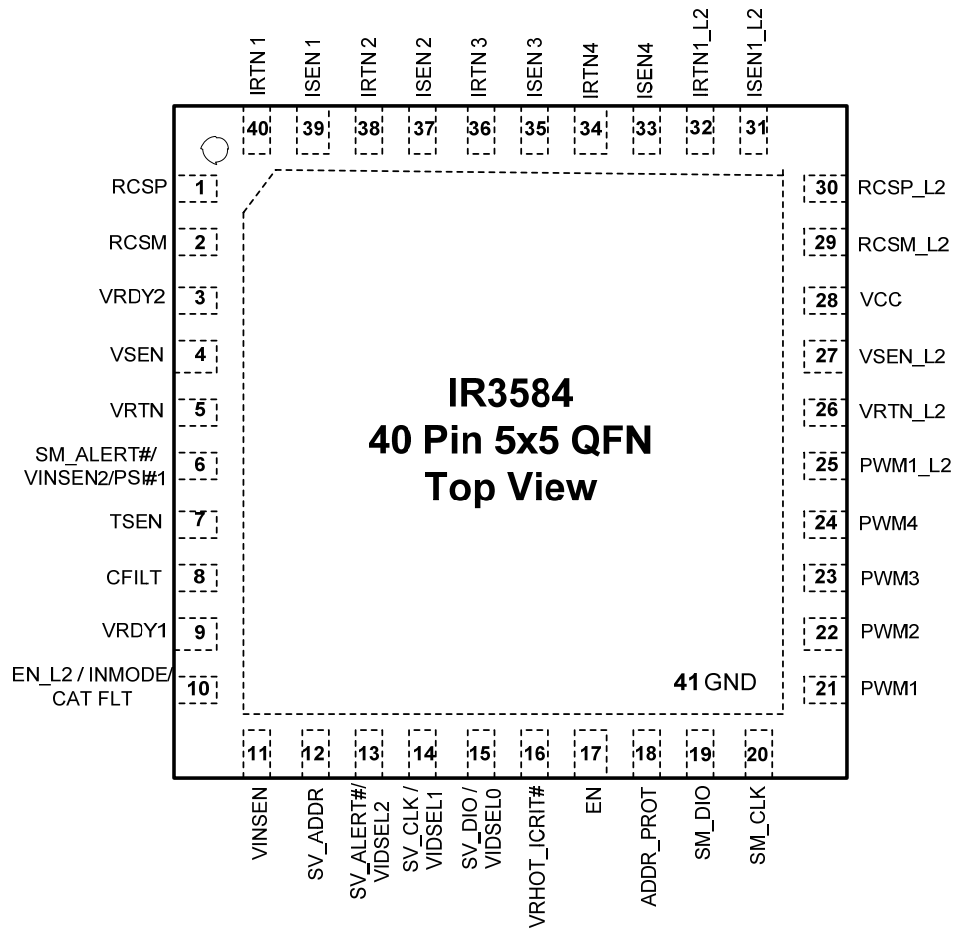
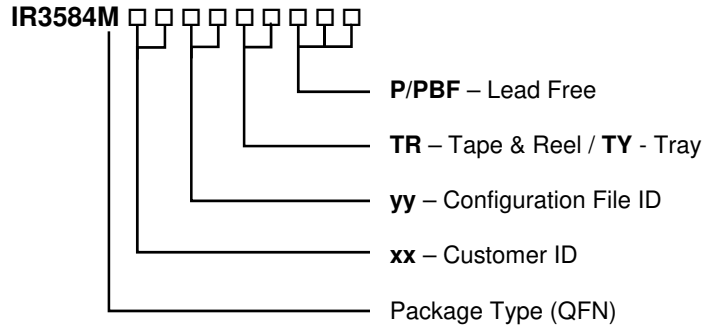

Figure 1: IR3584 Pin Diagram

**FUNCTIONAL BLOCK DIAGRAM**

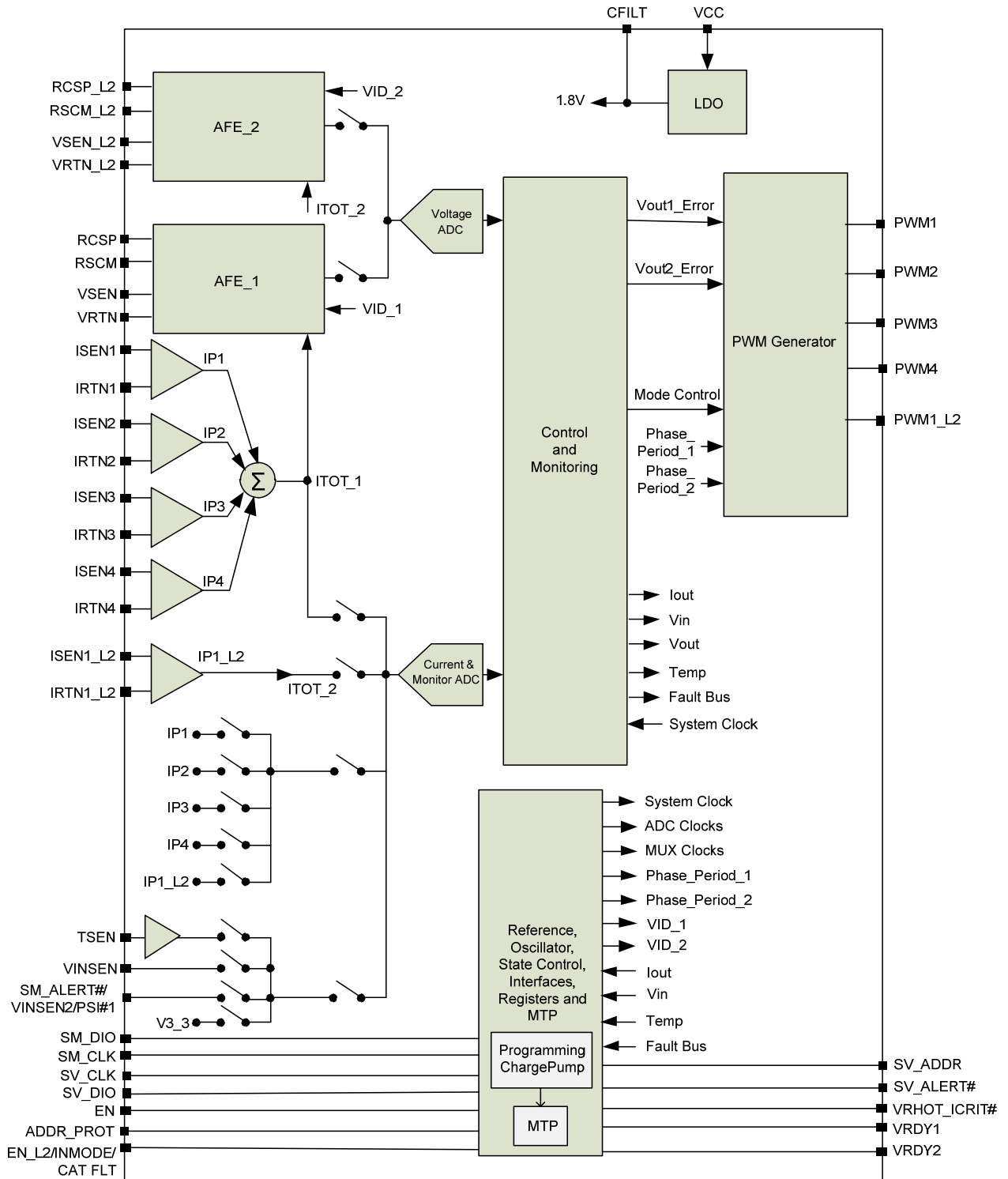

Figure 2: IR3584 Block Diagram

**TYPICAL APPLICATION DIAGRAM**

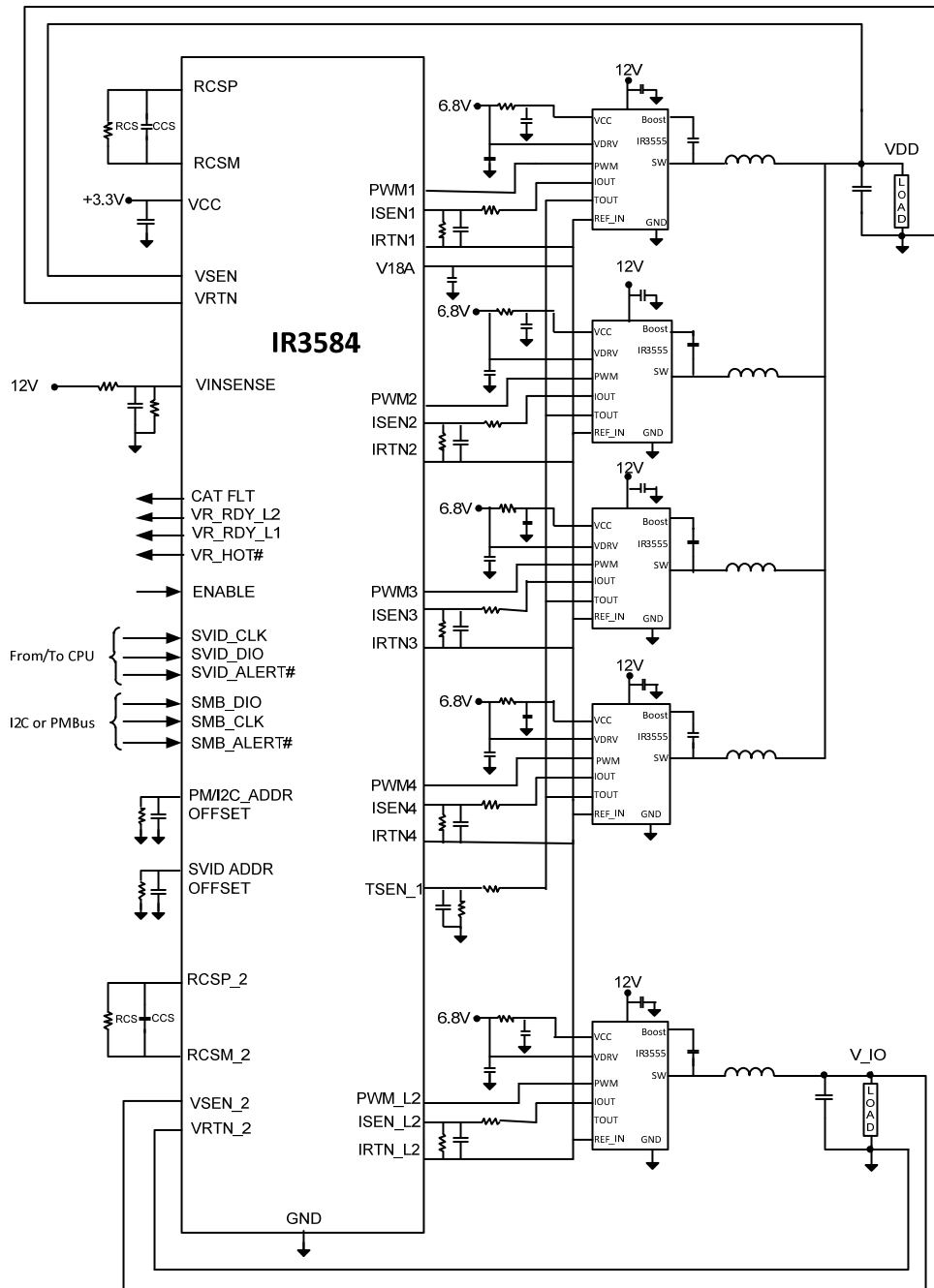

Figure 3: VR using IR3584 Controller and IR3555 powIRstages in 4+1 Configuration

Data and specifications subject to change without notice.  
This product will be designed and qualified for the Industrial market.  
Qualification Standards can be found on IR's Web site.

International  
**IR** Rectifier

**IR WORLD HEADQUARTERS:** 233 Kansas St., El Segundo, California 90245, USA Tel: (310) 252-7105  
TAC Fax: (310) 252-7903

Visit us at [www.irf.com](http://www.irf.com) for sales contact information.  
[www.irf.com](http://www.irf.com)