



Chipsmall Limited consists of a professional team with an average of over 10 year of expertise in the distribution of electronic components. Based in Hongkong, we have already established firm and mutual-benefit business relationships with customers from,Europe,America and south Asia,supplying obsolete and hard-to-find components to meet their specific needs.

With the principle of "Quality Parts,Customers Priority,Honest Operation,and Considerate Service",our business mainly focus on the distribution of electronic components. Line cards we deal with include Microchip,ALPS,ROHM,Xilinx,Pulse,ON,Everlight and Freescale. Main products comprise IC,Modules,Potentiometer,IC Socket,Relay,Connector.Our parts cover such applications as commercial,industrial, and automotives areas.

We are looking forward to setting up business relationship with you and hope to provide you with the best service and solution. Let us make a better world for our industry!



Contact us

Tel: +86-755-8981 8866 Fax: +86-755-8427 6832

Email & Skype: info@chipsmall.com Web: www.chipsmall.com

Address: A1208, Overseas Decoration Building, #122 Zhenhua RD., Futian, Shenzhen, China



FEATURES

- Single 5V to 21V application
- Wide Input Voltage Range from 1.5V to 21V with external Vcc
- Output Voltage Range: 0.6V to 0.86*P_{Vin}
- 0.5% accurate Reference Voltage
- Enhanced line/load regulation with Feed-Forward
- Programmable Switching Frequency up to 1.5MHz
- Internal Digital Soft-Start
- Enable input with Voltage Monitoring Capability
- Remote Sense Amplifier with True Differential Voltage Sensing
- Thermally compensated current limit and Hiccup Mode Over Current Protection
- Smart LDO to enhance efficiency
- V_p for tracking applications and sequencing
- V_{ref} is available externally to enable margining
- External synchronization with Smooth Clocking
- Dedicated output voltage sensing for power good indication and overvoltage protection which remains active even when Enable is low.
- Enhanced Pre-Bias Start up
- Body Braking to improve transient
- Integrated MOSFET drivers and Bootstrap diode
- Thermal Shut Down
- Post Package trimmed rising edge dead-time
- Programmable Power Good Output with tracking
- Small Size 5mm x 7mm PQFN
- Operating Junction Temp: -40°C < T_j < 125°C
- Lead-free, Halogen-free and RoHS Compliant

DESCRIPTION

The IR3846 Sup*IR*Buck® is an easy-to-use, fully integrated and highly efficient DC/DC regulator. The onboard PWM controller and MOSFETs make IR3846 a space-efficient solution, providing accurate power delivery for low output voltage and high current applications.

IR3846 is a versatile regulator which offers programmability of switching frequency and current limit while operating in wide input and output voltage range.

The switching frequency is programmable from 300 kHz to 1.5MHz for an optimum solution.

It also features important protection functions, such as Over Voltage Protection (OVP), Pre-Bias startup, hiccup current limit and thermal shutdown to give required system level security in the event of fault conditions.

APPLICATIONS

- Netcom Applications
- Embedded Telecom Systems
- Server Application
- Distributed Point of Load Power Architectures
- Storage Applications

ORDERING INFORMATION

Base Part Number	Package Type	Standard Pack		Orderable Part Number
		Form	Quantity	
IR3846	PQFN 5mm x 7mm	Tape and Reel	4000	IR3846MTRPBF

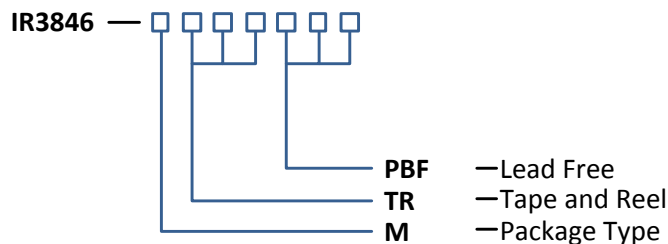

BASIC APPLICATION

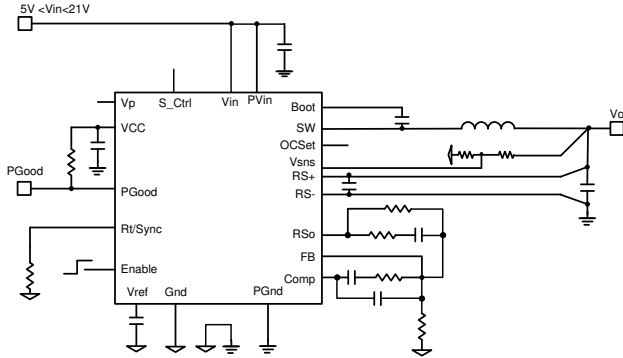

Figure 1: IR3846 Basic Application Circuit

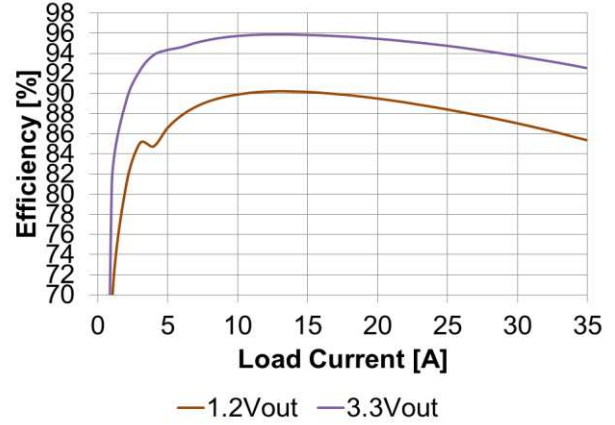
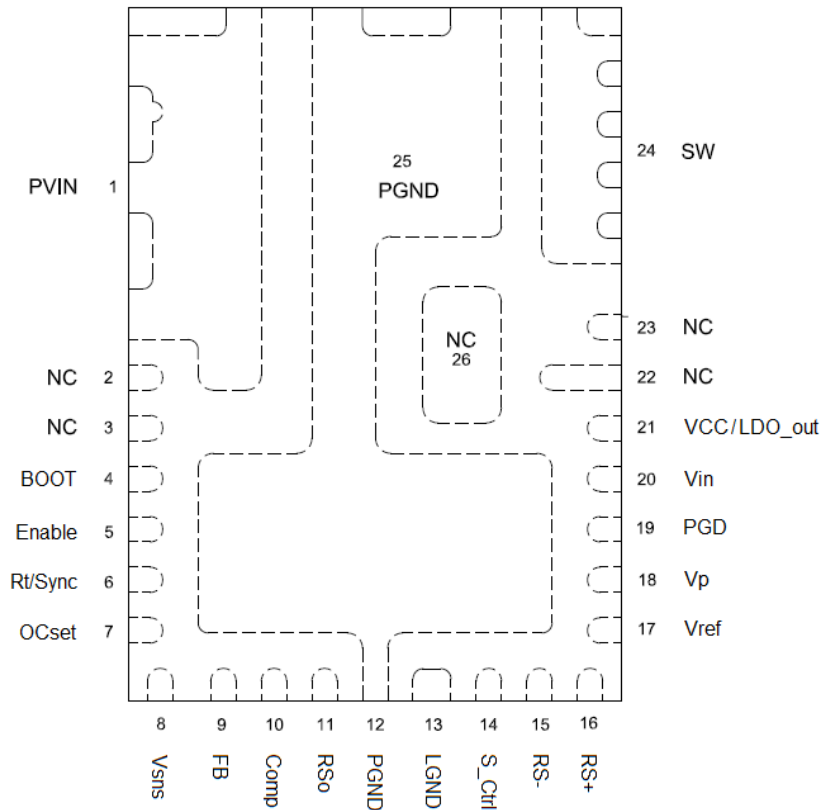

Figure 2: Efficiency [Vin=12V, Fsw=600kHz]

PIN DIAGRAM

5mm X 7mm POWER QFN
Top View



FUNCTIONAL BLOCK DIAGRAM

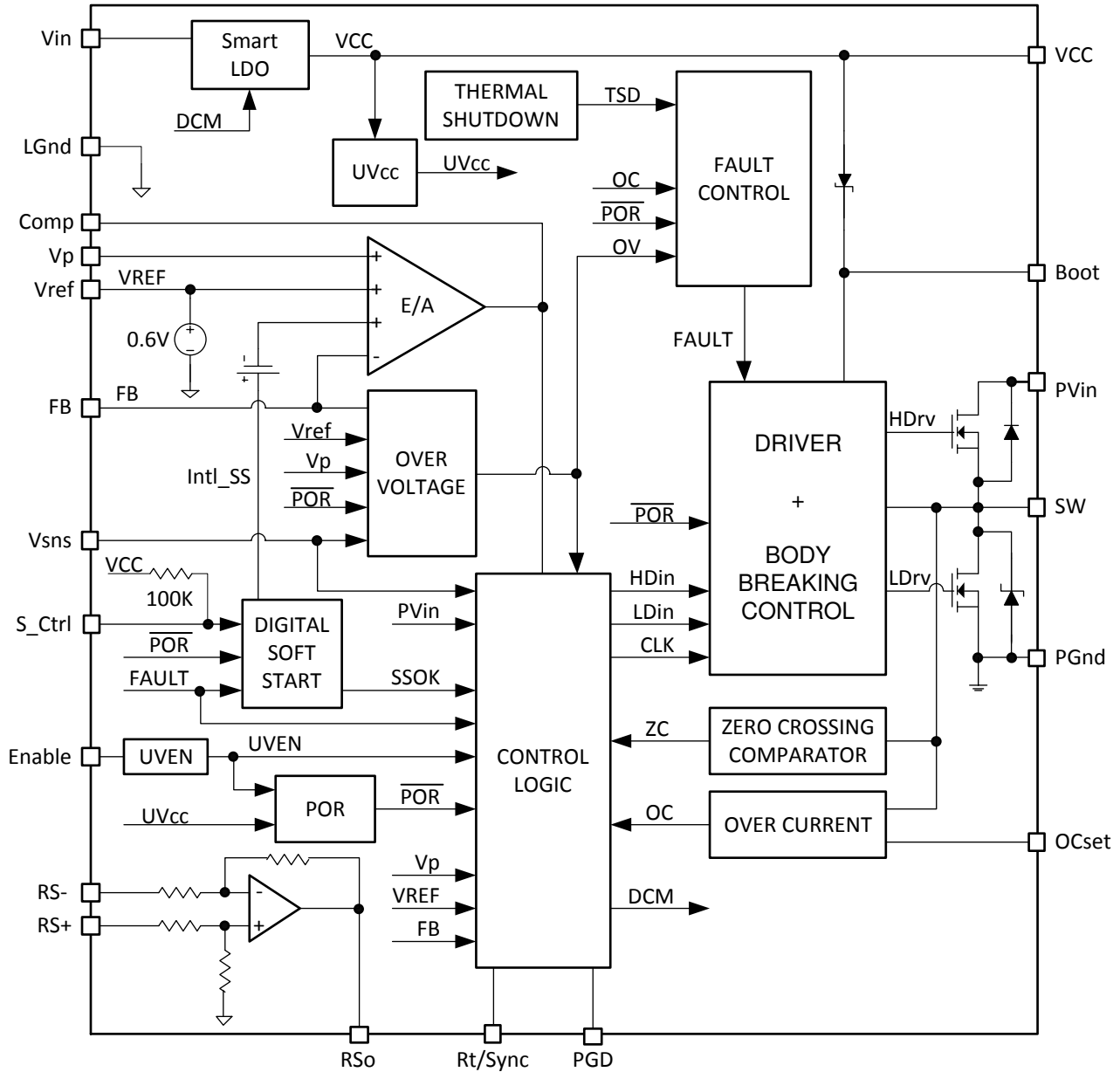

Figure 3: IR3846 Simplified Block Diagram

PIN DESCRIPTIONS

PIN #	PIN NAME	PIN DESCRIPTION
1	PVin	Input voltage for power stage. Bypass capacitors between PVin and PGND should be connected very close to this pin and PGND; also forms input to feedforward block
2, 3, 22, 23, 26	NC	No Connect
4	Boot	Supply voltage for high side driver
5	Enable	Enable pin to turning on and off the IC.
6	Rt/Sync	Use an external resistor from this pin to LGND to set the switching frequency, very close to the pin. This pin can also be used for external synchronization.
7	OCset	Current limit setpoint. This pin allows the trip point to be set to one of three possible settings by either floating, tying to VCC or tying to PGnd.
8	Vsns	Sense pin for OVP and PGood
9	FB	Inverting input to the error amplifier. This pin is connected directly to the output of the regulator or to the output of the remote sense amplifier, via resistor divider to set the output voltage and provide feedback to the error amplifier.
10	COMP	Output of error amplifier. An external resistor and capacitor network is typically connected from this pin to FB to provide loop compensation.
11	RS _o	Remote Sense Amplifier Output
12, 25	PGND	Power ground. This pin should be connected to the system's power ground plane. Bypass capacitors between PVin and PGND should be connected very close to PVIN pin (pin 1) and this pin.
13	LGND	Signal ground for internal reference and control circuitry.
14	S_Ctrl	Soft start/stop control. A high logic input enables the device to go into the internal soft start; a low logic input enables the output soft discharged. Pin is internally pulled high when this function is not used.
15	RS ₋	Remote Sense Amplifier input. Connect to ground at the load.
16	RS ₊	Remote Sense Amplifier input. Connect to output at the load.
17	Vref	External reference voltage can be used for margining operation. A capacitor between 100pF and 180pF should be connected between this pin and LGnd. Tie to LGnd for tracking function.
18	Vp	Used for voltage sequencing and tracking. Leave open if sequencing or tracking is not needed, ensuring that there is no capacitor on the pin.
19	PGD	Power Good status pin. Output is open drain. Connect a pull up resistor from this pin to VCC.
20	Vin	Input Voltage for LDO.
21	VCC/LDO _{out}	Bias Voltage for IC and driver section, output of LDO. Add a minimum of 4.7uF bypass cap from this pin to PGnd.
24	SW	Switch node. This pin is connected to the output inductor.

ABSOLUTE MAXIMUM RATINGS

Stresses beyond those listed under “Absolute Maximum Ratings” may cause permanent damage to the device. These are stress ratings only and functional operation of the device at these or any other conditions beyond those indicated in the operational sections of the specifications are not implied.

PVin	-0.3V to 25V	
Vin	-0.3V to 25V	
VCC	-0.3V to 8V (Note 1)	
SW	-0.3V to 25V (DC), -4V to 25V (AC, 100ns)	
BOOT	-0.3V to 33V	
BOOT to SW	-0.3V to VCC + 0.3V (Note 2)	
Input/Output pins	-0.3V to 3.9V	
RS+, RS-, RSo, PGD, Enable, OCset, S_Ctrl	-0.3V to 8V (Note 1)	
PGND to LGND, RS- to LGND	-0.3V to + 0.3V	
Junction Temperature Range	-40°C to 150°C	
Storage Temperature Range	-55°C to 150°C	
ESD	Machine Model	Class A
	Human Body Model	Class 1C
	Charged Device Model	Class III
Moisture Sensitivity level	JEDEC Level 2 @ 260°C	
RoHS Compliant	Yes	

Note:

1. VCC must not exceed 7.5V for Junction Temperature between -10°C and -40°C.
2. Must not exceed 8V.

THERMAL INFORMATION

Thermal Resistance, Junction to Case (θ_{JC_TOP})	30 °C/W
Thermal Resistance, Junction to PCB (θ_{JB})	2.71 °C/W
Thermal Resistance, Junction to Ambient (θ_{JA}) (Note 3)	14.3 °C/W

Note:

3. Thermal resistance (θ_{JA}) is measured with components mounted on a high effective thermal conductivity test board in free air.

ELECTRICAL SPECIFICATIONS

RECOMMENDED OPERATING CONDITIONS

SYMBOL	DEFINITION	MIN	MAX	UNIT
PVin	Input Bus Voltage *	1.5	21	V
Vin	Supply Voltage	5.0	21	
VCC	Supply Voltage **	4.5	7.5	
Boot to SW	Supply Voltage	4.5	7.5	
V _O	Output Voltage	0.6	0.86 PVin	
I _O	Output Current	0	±35	A
Fs	Switching Frequency	300	1500	kHz
T _J	Junction Temperature	-40	125	°C

* SW node must not exceed 25V

** When VCC is connected to an externally regulated supply, also connect Vin.

ELECTRICAL CHARACTERISTICS

Unless otherwise specified, these specification apply over, $1.5V < PVin < 21V$, $4.5V < VCC < 7.5V$, $0^{\circ}C < T_J < 125^{\circ}C$.

Typical values are specified at $T_A = 25^{\circ}C$.

PARAMETER	SYMBOL	CONDITIONS	MIN	TYP	MAX	UNIT
Power Loss						
Power Loss	P _{Loss}	V _{in} = PV _{in} = 12V, V _O = 1.2V, I _O = 35A, Fs = 600kHz, L=0.250uH, T _A = 25°C, Note 4		5.3		W
MOSFET R_{ds(on)}						
Top Switch	Rds(on)_Top	V _{Boot} - V _{SW} = 6.8V, I _D = 35A, Without Cu Clip, T _J = 25°C		3.1	4	mΩ
Bottom Switch	Rds(on)_Bot	VCC = 6.8V, I _D = 35A, With Cu Clip, T _J = 25°C		1.27	1.64	
Reference Voltage						
Feedback Voltage	V _{FB}			0.6		V
Accuracy		Vref=0.6V, 0°C < T _J < 105°C	-0.5		+0.5	%
		Vref=0.6V, -40°C < T _J < 125°C	-1.0		+1.0	
Sink Current	Isink_Vref	Vref=0.7V	12.7	16.0	19.3	μA
Source Current	Isrc_Vref	Vref=0.5V	12.7	16.0	19.3	
Vref Comparator Threshold	Vref_disable	Vref Pin connected externally			0.15	V

PARAMETER	SYMBOL	CONDITIONS	MIN	TYP	MAX	UNIT
	Vref_enable		0.4			V
Supply Current						
V _{in} Supply Current (Standby)	I _{in(Standby)}	V _{in} =21V, Enable low, No Switching		300	425	μA
V _{in} Supply Current (Dyn)	I _{in(Dyn)}	V _{in} =21V, Enable high, F _s = 600kHz			40	mA
VCC Supply Current (Standby)	I _{cc(Standby)}	Enable low, VCC=7V, No Switching		300	425	μA
VCC Supply Current (Dyn)	I _{cc(Dyn)}	Enable high, VCC=7V, F _s = 600kHz			40	mA
Under Voltage Lockout						
VCC–Start–Threshold	VCC_UVLO_Start	VCC Rising Trip Level	4.0	4.2	4.4	V
VCC–Stop–Threshold	VCC_UVLO_Stop	VCC Falling Trip Level	3.7	3.9	4.2	
Enable–Start–Threshold	Enable_UVLO_Start	Supply ramping up	1.14	1.2	1.36	V
Enable–Stop–Threshold	Enable_UVLO_Stop	Supply ramping down	0.9	1.0	1.06	
Enable leakage current	I _{en}	Enable=3.3V			1	μA
Oscillator						
Rt Voltage				1		V
Frequency Range	F _s	Rt=80.6k	270	300	330	kHz
		Rt=39.2k	540	600	660	
		Rt=15k	1350	1500	1650	
Ramp Amplitude	V _{ramp}	PV _{in} =6.8V, PV _{in} (max) slew rate=1V/us, Note 4		1.02		V _{p-p}
		PV _{in} =12V, PV _{in} (max) slew rate=1V/us, Note 4		1.8		
		PV _{in} =16V, PV _{in} (max) slew rate=1V/us, Note 4		2.4		
Ramp Offset	Ramp (os)	Note 4		0.16		V
Min Pulse Width	T _{min} (ctrl)	Note 4			50	ns
Fixed Off Time		Note 4		200	230	ns
Max Duty Cycle	D _{max}	F _s =300kHz, PV _{in} =V _{in} =12V	86			%
Sync Frequency Range		Note 4	270		1650	kHz
Sync Pulse Duration			100	200		ns
Sync Level Threshold	High		3			V
	Low				0.6	

PARAMETER	SYMBOL	CONDITIONS	MIN	TYP	MAX	UNIT
Error Amplifier						
Input Offset Voltage	Vos_Vref	VFb – Vref, Vref = 0.6V	-1.5		+1.5	% Vref
	Vos_Vp	VFb – Vp, Vp = 0.6V	-1.5		+1.5	%Vp
Input Bias Current	IFb(E/A)		-0.5		+0.5	μA
Input Bias Current	IVp(E/A)		0		4	μA
Sink Current	Isink(E/A)		0.4	0.85	1.2	mA
Source Current	Isource(E/A)		4	7.5	11	mA
Slew Rate	SR	Note 4	7	12	20	V/μs
Gain-Bandwidth Product	GBWP	Note 4	20	30	40	MHz
DC Gain	Gain	Note 4	100	110	120	dB
Maximum Output Voltage	Vmax(E/A)		1.7	2	2.3	V
Minimum Output Voltage	Vmin(E/A)				100	mV
Common Mode Voltage	Vcm_Vp	Note 4	0		1.2	V
Margining Range	Vmarg_Vref	Note 4	0.4		1.2	V
Remote Sense Differential Amplifier						
Unity Gain Bandwidth	BW_RS	Note 4	3	6.4	9	MHz
DC Gain	Gain_RS	Note 4		110		dB
Offset Voltage	Offset_RS	Vref=0.6V, 0°C < Tj < 85°C	-1.5	0	1.5	mV
		Vref=0.6V, -40°C < Tj < 125°C	-2		2	mV
Source Current	Isource_RS		3	13	20	mA
Sink Current	Isink_RS		0.4	1	2	mA
Slew Rate	Slew_RS	Note 4, Cload = 100pF	2	4	8	V/μs
RS+ input impedance	Rin_RS+		45	63	85	kohm
RS- input impedance	Rin_RS-	Note 4		63		kohm
Maximum Voltage	Vmax_RS	V(VCC) – V(RSo)	0.5	1	1.5	V
Minimum Voltage	Min_RS			50		mV
Internal Digital Soft Start						
Soft Start Clock	Clk_SS	Note 4	180	200	220	kHz
Soft Start Ramp Rate	Ramp(SS_Start)	Note 4	0.3	0.4	0.5	mV / μs
S_CTRL Threshold	High		2.4			V

PARAMETER	SYMBOL	CONDITIONS	MIN	TYP	MAX	UNIT
	Low				0.6	V
Bootstrap Diode						
Forward Voltage		I(Boot) = 30mA	360	520	960	mV
Switch Node						
SW Leakage Current	I _{sw}	SW = 0V, Enable = 0V			1	μA
		SW = 0V, Enable = HIGH, V _p =0 V				
Internal Regulator (VCC/LDO)						
Output Voltage	VCC	V _{in} (min) = 7.2V, I _o =0-30mA, C _{load} = 2.2μF, DCM=0	6.3	6.8	7.1	V
		V _{in} (min) = 7.2V, I _o =0-30mA, C _{load} = 2.2μF, DCM=1	4	4.4	4.8	
VCC dropout	VCC _{drop}	V _{in} = 7V, I _o =70 mA, C _{load} = 2.2μF			0.7	V
Short Circuit Current	I _{short}	Note 4		70		mA
Zero-crossing Comparator Delay	T _{dly_zc}			256 / F _s		s
Zero-crossing Comparator Offset	V _{os_zc}	Note 4		0		mV
Body Braking						
BB Threshold	BB _{threshold}	F _b > V _{ref} , Sw duty cycle, Note 3		0		%
FAULTS						
Power Good						
Power Good Low Upper Threshold	VPG _{low} (upper)	V _{sns} Rising, 0.4V < V _{ref} < 1.2V	115	120	125	% V _{ref}
		V _{sns} Rising, V _{ref} < 0.1V	115	120	125	% V _p
Power Good Low Upper Threshold Falling delay	VPG _{low} (upper)_Dly	V _{sns} > VPG _{low} (upper)	1.5	2.5	3.5	μs
Power Good High Lower Threshold	VPG _{high} (lower)	V _{sns} Rising, 0.4V < V _{ref} < 1.2V		95		% V _{ref}
		V _{sns} Rising, V _{ref} < 0.1V		95		% V _p
Power Good High Lower Threshold Rising Delay	VPG _{high} (lower)_Dly	V _{sns} rising		1.28		ms
Power Good Low Lower Threshold	VPG _{low} (lower)	V _{sns} falling, 0.4V < V _{ref} < 1.2V		90		% V _{ref}
		V _{sns} falling,		90		%V _p

PARAMETER	SYMBOL	CONDITIONS	MIN	TYP	MAX	UNIT
		0.1V < Vref				
Power Good Low Lower Threshold Falling delay	VPG_low(lower)_Dly	Vsns < VPG_low(lower)	101	150	199	μs
PGood Voltage Low	PG (voltage)	I _{PGood} = -5mA			0.5	V
Tracker Comparator Upper Threshold	VPG(tracker_upper)	Vp Rising, Vref < 0.1V		0.4		V
Tracker Comparator Lower Threshold	VPG(tracker_lower)	Vp Falling, Vref < 0.1V		0.3		V
Tracker Comparator Delay	Tdelay(tracker)	Vp Rising, Vref < 0.1V		1.28		ms
Over Voltage Protection (OVP)						
OVP Trip Threshold	OVP (trip)	Vsns Rising, 0.45V < Vref < 1.2V	115	120	125	% Vref
		Vsns Rising, Vref < 0.1V	115	120	125	% Vp
OVP Fault Prop Delay	OVP (delay)	Vsns rising	1.5	2.5	3.5	μs
Over-Current Protection						
OC Trip Current	I _{TRIP}	OCSet=VCC, VCC = 6.8V, T _J = 25°C	41	44.4	48	A
		OCSet=floating, VCC = 6.8V, T _J = 25°C	32	35	38	A
		OCSet=PGnd, VCC =6.8V, T _J = 25°C	24	26.88	30	A
Hiccup blanking time	Tblk_Hiccup	Note 4		20.48		ms
Thermal Shutdown						
Thermal Shutdown		Note 4		145		°C
Hysteresis		Note 4		20		°C

Notes:

4. Guaranteed by design but not tested in production.

TYPICAL EFFICIENCY AND POWER LOSS CURVES

$P_{Vin} = V_{in} = 12V$, $V_{CC} = \text{Internal LDO}$, $I_o=0-35A$, $F_s= 600kHz$, Room Temperature, $LFM=200$. Note that the losses of the inductor, input and output capacitors are also considered in the efficiency and power loss curves. The table below shows the indicator used for each of the output voltages in the efficiency measurement.

VOUT (V)	LOUT (uH)	P/N	DCR (mΩ)
1.2	0.25	744309025 (Wurth Electronik)	0.165
1.8	0.33	744309033 (Wurth Electronik)	0.165
3.3	0.33	744309033 (Wurth Electronik)	0.165
5.0	0.33	744309033 (Wurth Electronik)	0.165

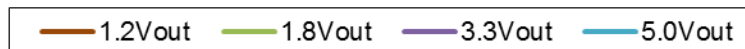
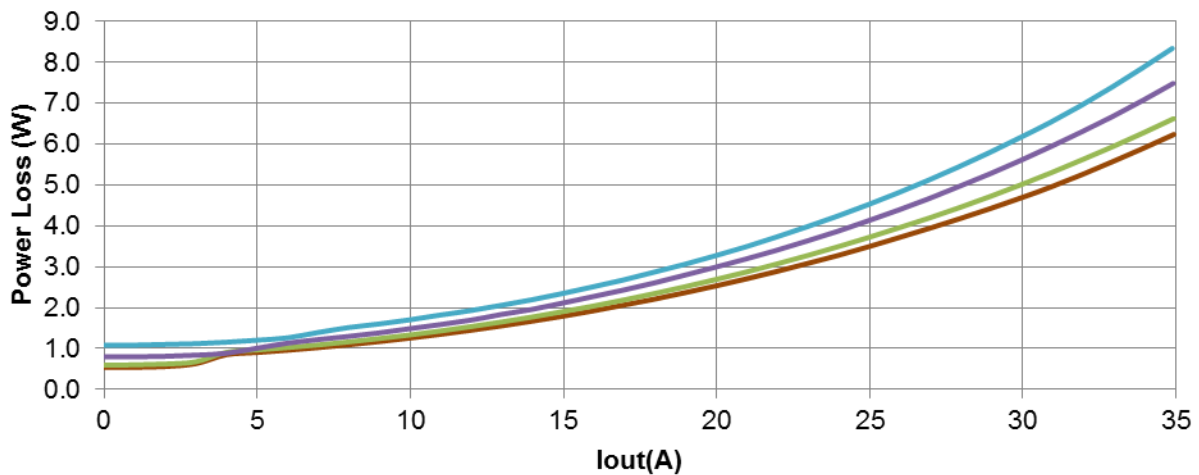
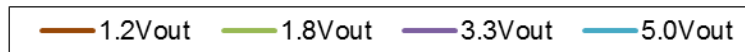
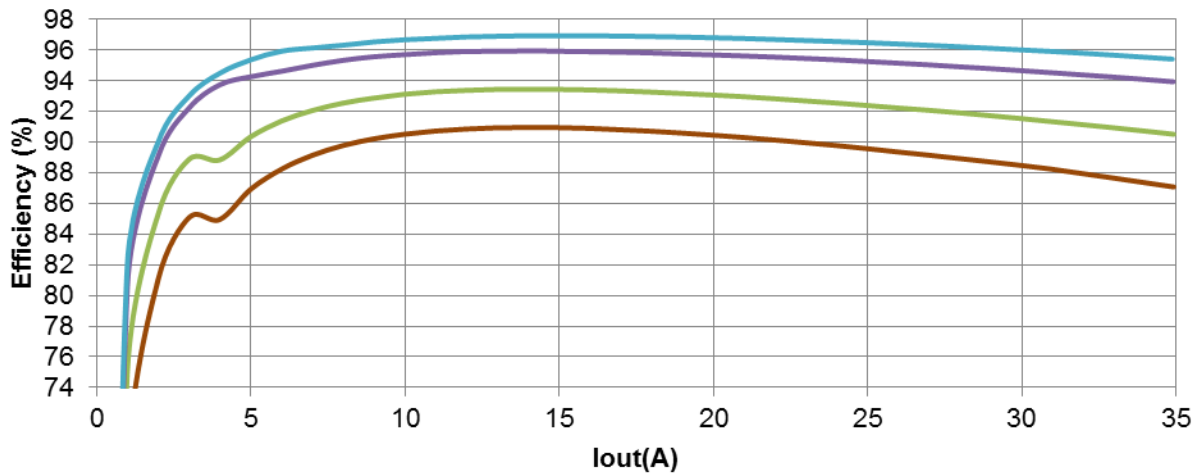

TYPICAL EFFICIENCY AND POWER LOSS CURVES

$P_{Vin} = 12V$, $V_{in} = V_{CC} = 5V$, $I_o=0-35A$, $F_s= 600kHz$, Room Temperature, $LFM=200$. Note that the losses of the inductor, input and output capacitors are also considered in the efficiency and power loss curves. The table below shows the indicator used for each of the output voltages in the efficiency measurement.

VOUT (V)	LOUT (uH)	P/N	DCR (mΩ)
1.2	0.25	744309025 (Wurth Electronik)	0.165
1.8	0.33	744309033 (Wurth Electronik)	0.165
3.3	0.33	744309033 (Wurth Electronik)	0.165
5.0	0.33	744309033 (Wurth Electronik)	0.165

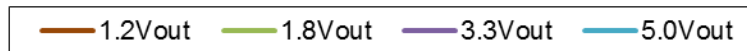
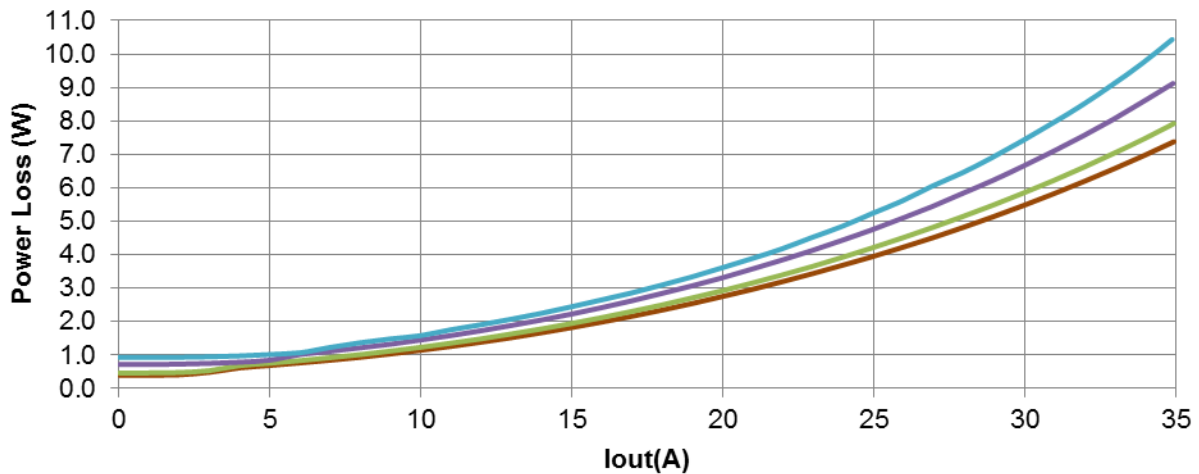
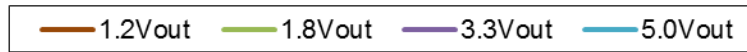
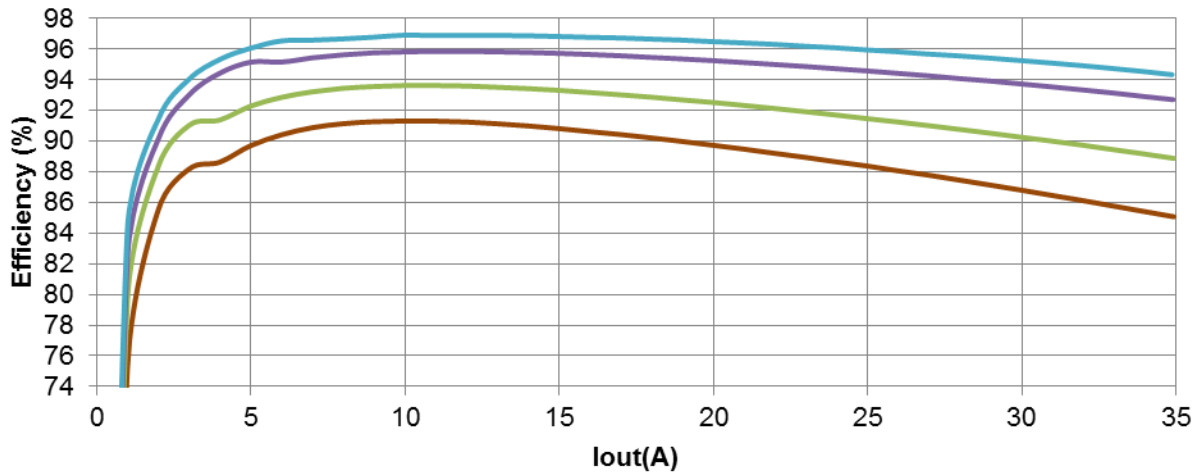

TYPICAL EFFICIENCY AND POWER LOSS CURVES

$P_{Vin} = V_{in} = V_{CC} = 5V$, $I_o=0-35A$, $F_s= 600kHz$, Room Temperature, $LFM=200$. Note that the losses of the inductor, input and output capacitors are also considered in the efficiency and power loss curves. The table below shows the indicator used for each of the output voltages in the efficiency measurement.

VOUT (V)	LOUT (uH)	P/N	DCR (mΩ)
1.0	0.19	SL40307A-R19KHF (ITG)	0.200
1.2	0.19	SL40307A-R19KHF (ITG)	0.200

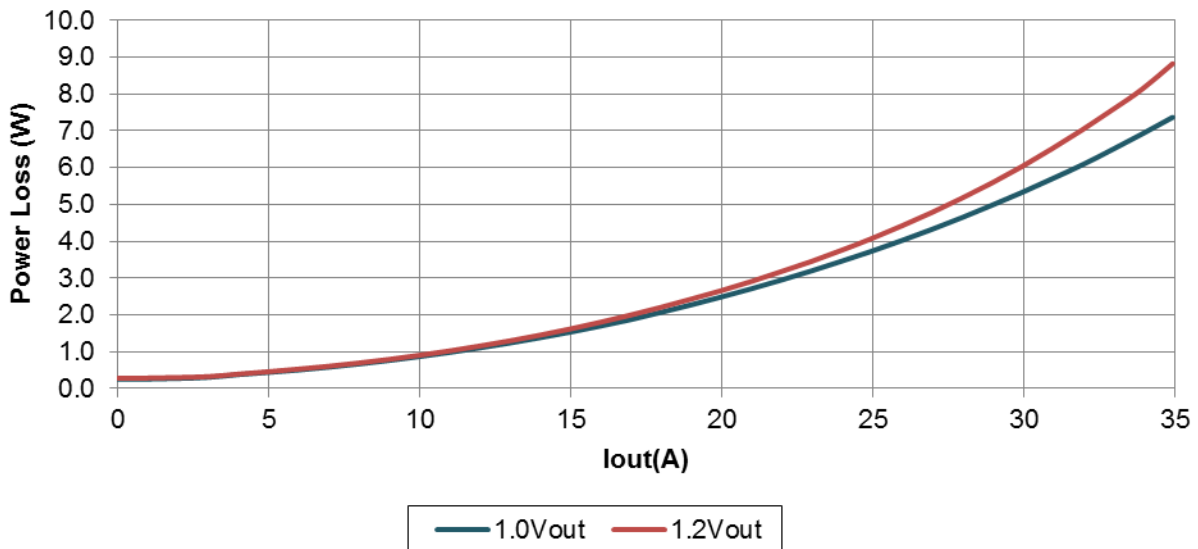
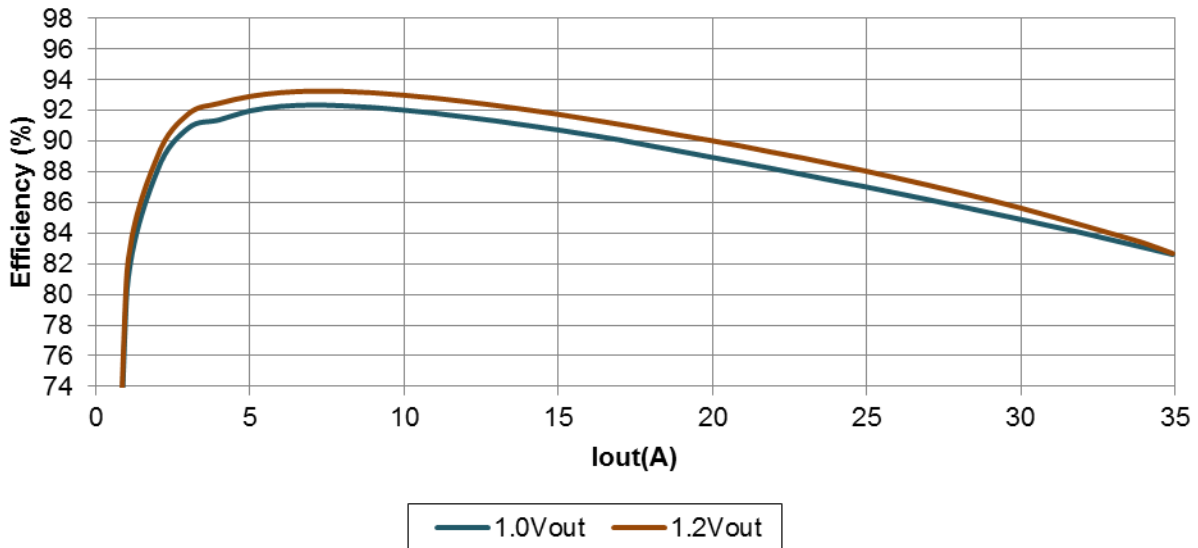

THERMAL DERATING CURVES

Measurements are done on IR3846 Evaluation board. PCB is a 6 layer board with 2 oz copper and FR4 material.

$V_{in}=P_{Vin}=12V$, $V_{out} = 1.2V$, $V_{CC}=\text{internal LDO (6.8V)}$, $F_s = 600\text{kHz}$

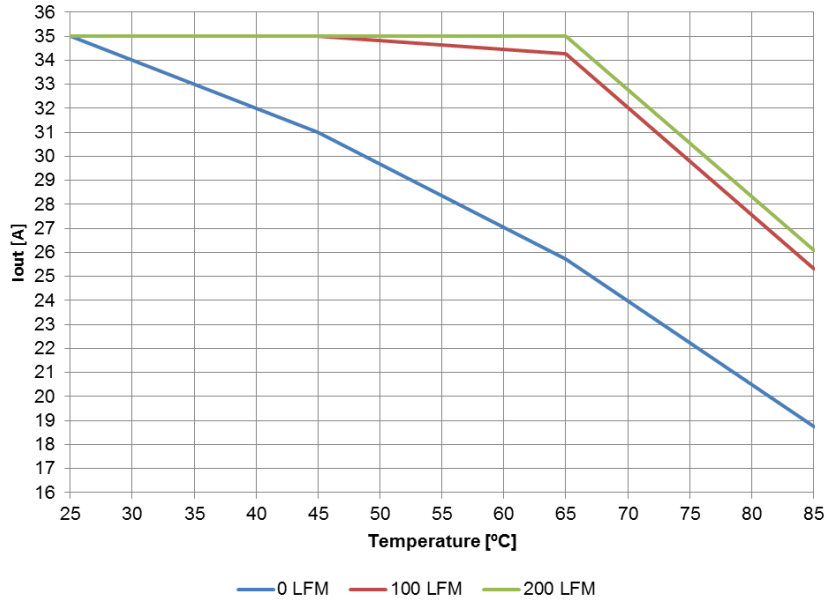

$V_{in}=P_{Vin}=12V$, $V_{out} = 3.3V$, $V_{CC}=\text{internal LDO (6.8V)}$, $F_s = 600\text{kHz}$

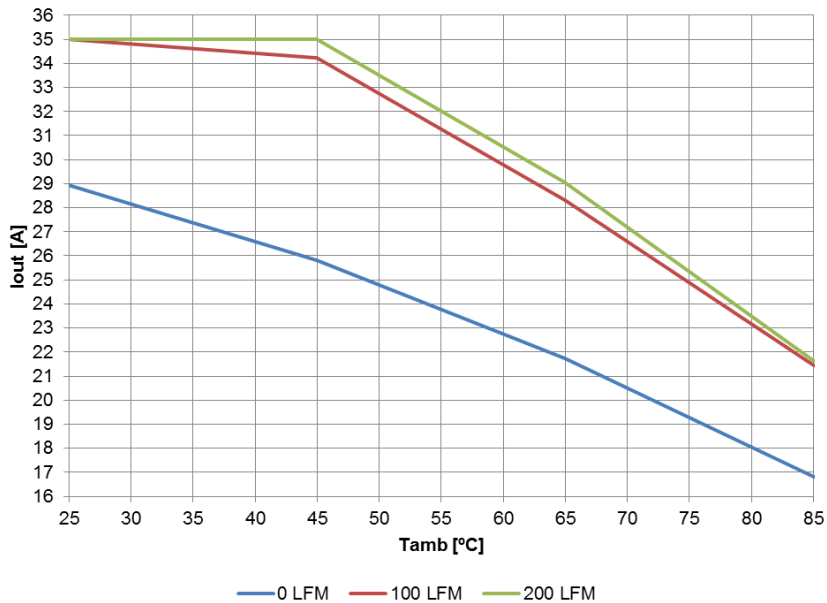

Note: International Rectifier Corporation specifies current rating of SupIRBuck devices conservatively. The continuous current load capability might be higher than the rating of the device if input voltage is 12V typical and switching frequency is below 600kHz. However, the maximum current is limited by the internal current limit and designers need to consider enough guard bands between load current and minimum current limit to guarantee that the device does not trip at steady state condition.

MOSFET RDSON VARIATION OVER TEMPERATURE

Rdson at VCC=6.8V

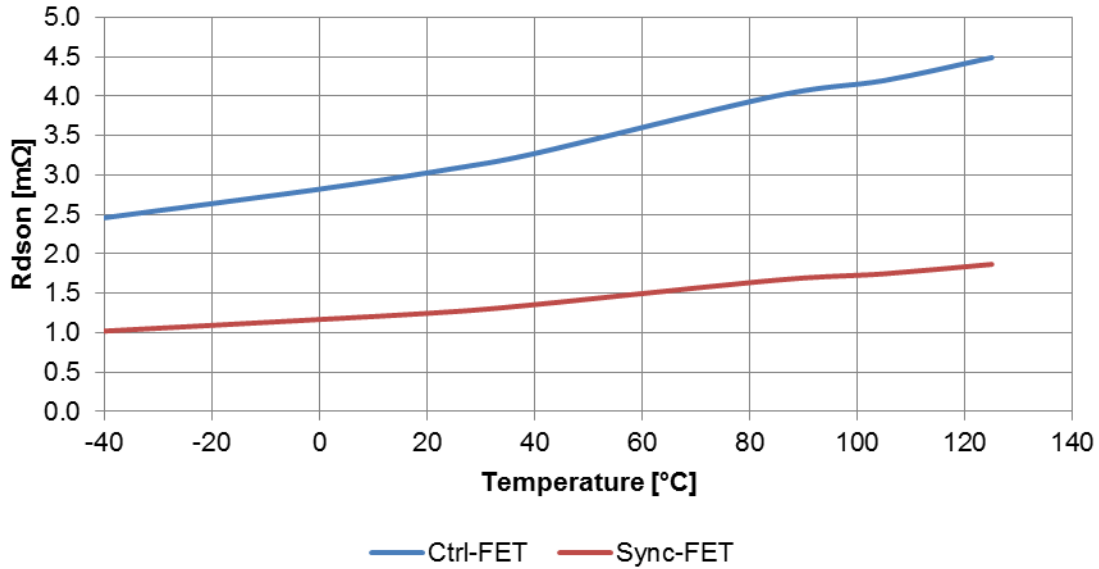

Rdson at VCC=5.0V

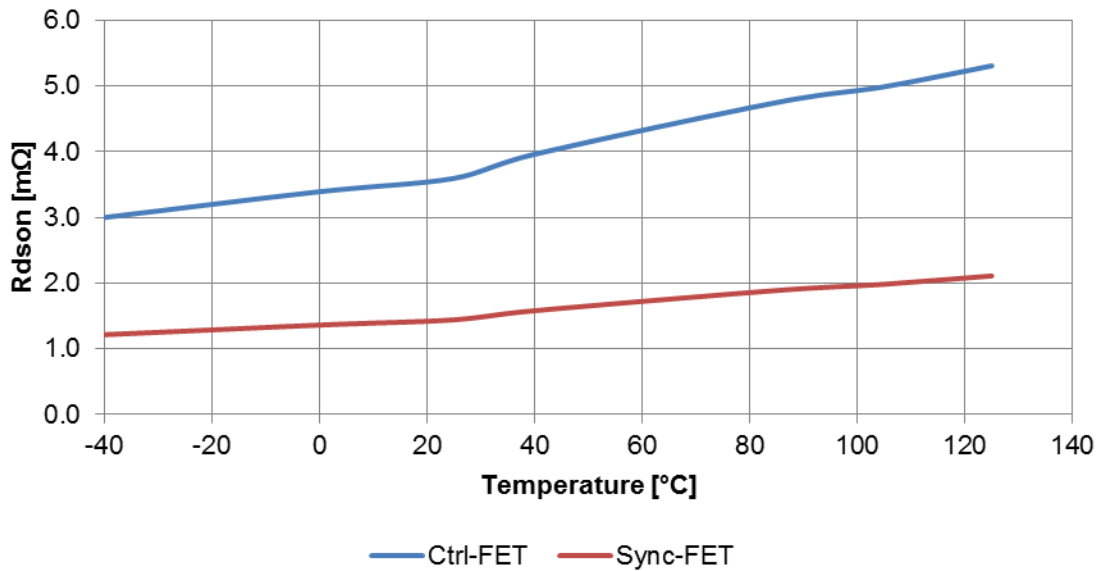

TYPICAL OPERATING CHARACTERISTICS (-40°C to +125°C)

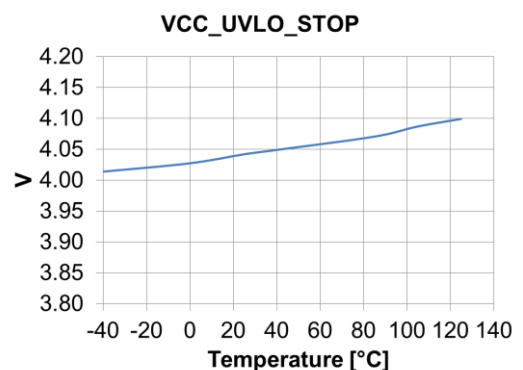
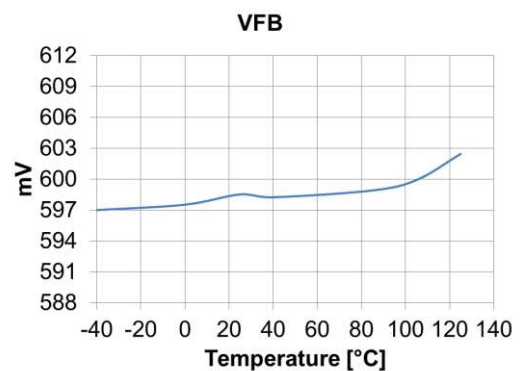
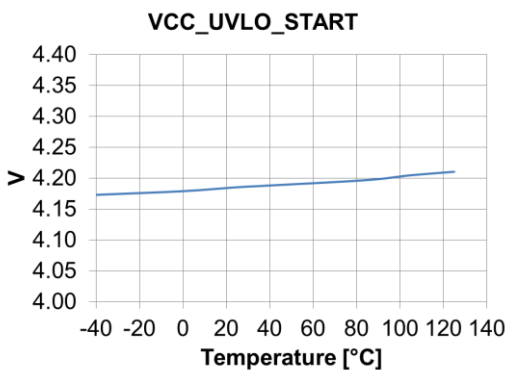
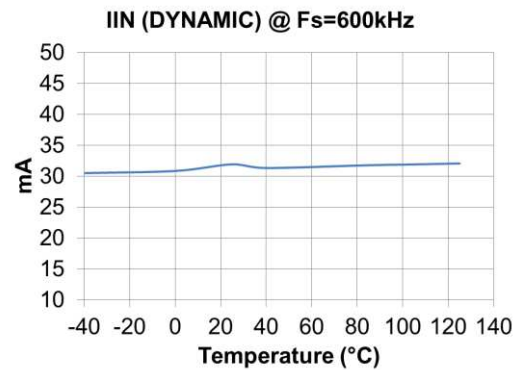
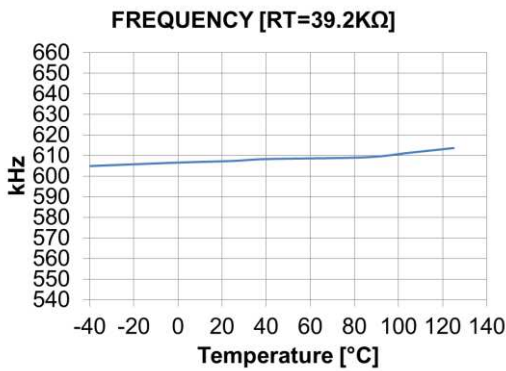
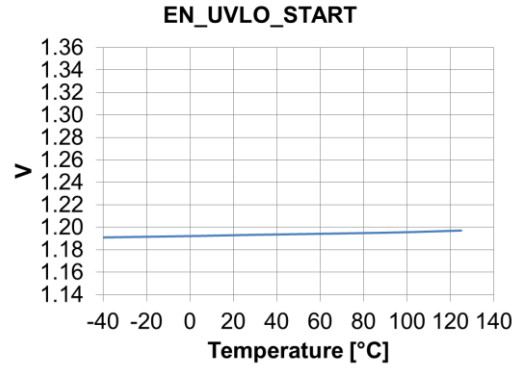
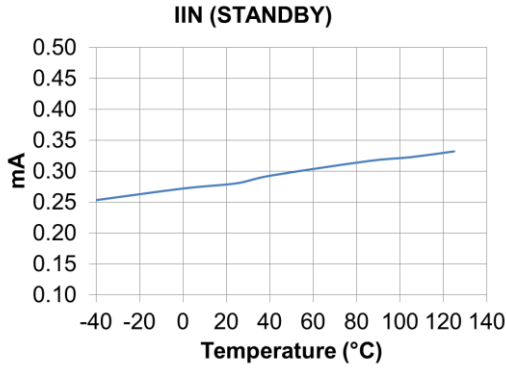

EN_UVLO_STOP

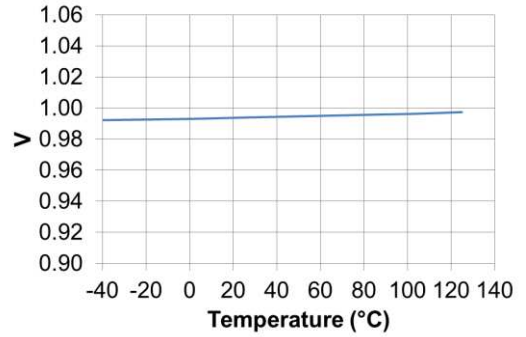

TYPICAL OPERATING CHARACTERISTICS (-40°C to +125°C)

VCC [DCM=1]

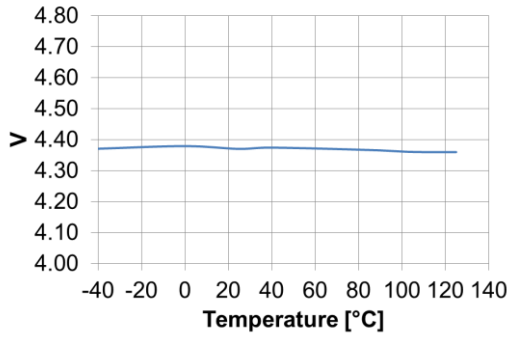

VPG_LOW(LOWER)_VR

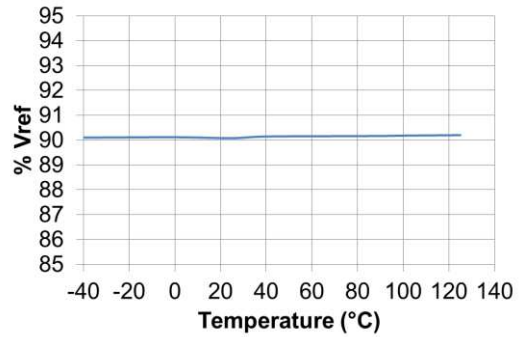

OVP_Vth and VPG_LOW (UPPER)_VR

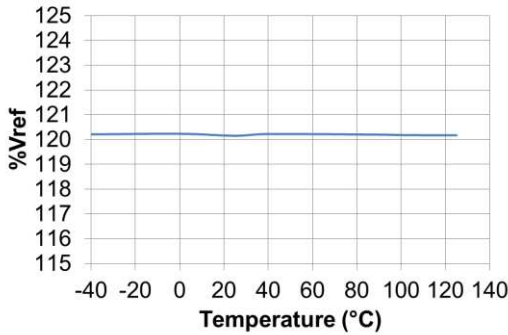

VCC [DCM=0]

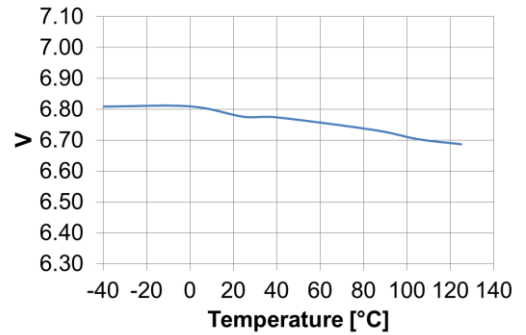

VPG_HIGH(LOWER)_VR

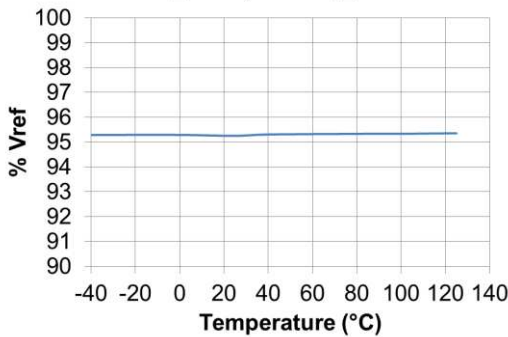

OVP_Vth and VPG_LOW(UPPER)_VP

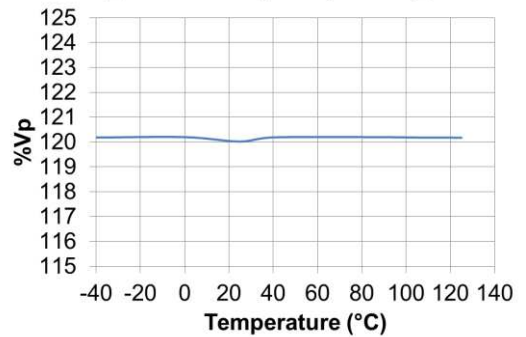

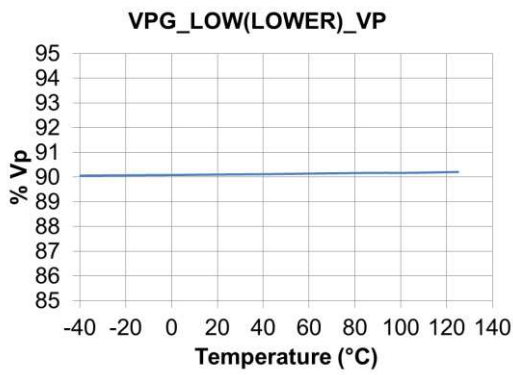
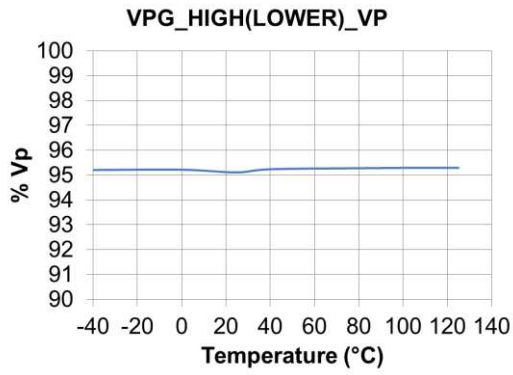

TYPICAL OPERATING CHARACTERISTICS (-40°C to +125°C)

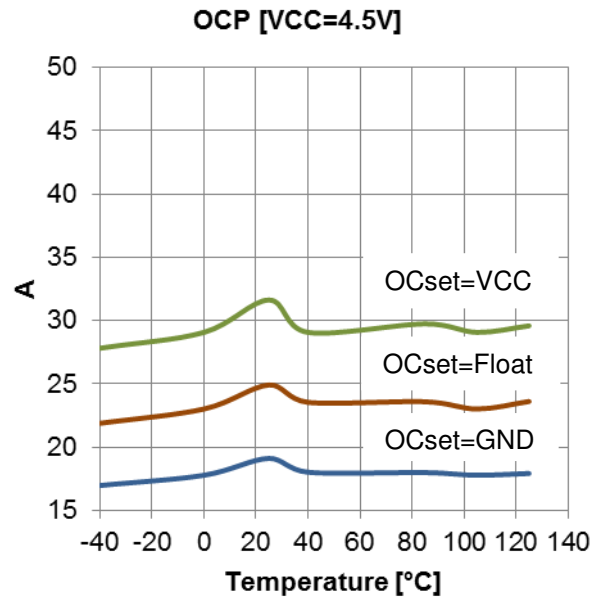
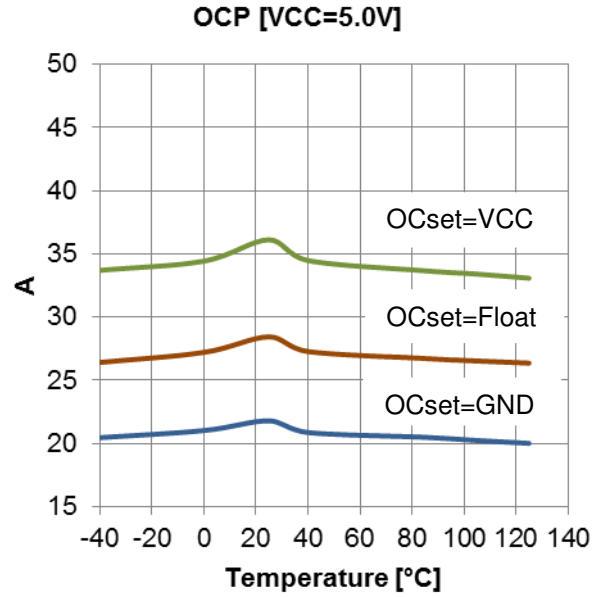
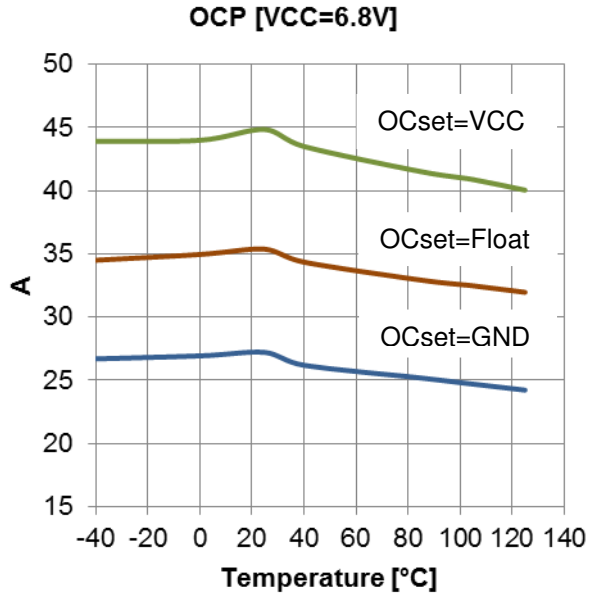

THEORY OF OPERATION

DESCRIPTION

The IR3846 uses a PWM voltage mode control scheme with external compensation to provide good noise immunity and maximum flexibility in selecting inductor values and capacitor types.

The switching frequency is programmable from 300kHz to 1.5MHz and provides the capability of optimizing the design in terms of size and performance.

IR3846 provides precisely regulated output voltage programmed via two external resistors from 0.6V to $0.86 \cdot P_{Vin}$.

The IR3846 operates with an internal bias supply (LDO) which is connected to the VCC pin. This allows operation with single supply. The bias voltage is variable according to load condition. If the output load current is less than half of the peak-to-peak inductor current, a lower bias voltage, 4.4V, is used as the internal gate drive voltage; otherwise, a higher voltage, 6.8V, is used.

This feature helps the converter to reduce power losses. The device can also be operated with an external bias from 4.5V to 7.5V, allowing an extended operating input voltage (P_{Vin}) range from 1.5V to 21V. For using the internal LDO supply, the V_{in} pin should be connected to P_{Vin} pin. If an external bias is used, it should be connected to VCC pin and the V_{in} pin should be shorted to VCC pin.

The device utilizes the on-resistance of the low side MOSFET (synchronous Mosfet) as current sense element. This method enhances the converter's efficiency and reduces cost by eliminating the need for external current sense resistor.

IR3846 includes two low $R_{ds(on)}$ MOSFETs using IR's HEXFET technology. These are specifically designed for high efficiency applications.

UNDER-VOLTAGE LOCKOUT AND POR

The under-voltage lockout circuit monitors the voltage of VCC pin and the Enable input. It assures that the MOSFET driver outputs remain in the off state whenever either of these two signals drops below the

set thresholds. Normal operation resumes once VCC and Enable rise above their thresholds.

The POR (Power On Ready) signal is generated when all these signals reach the valid logic level (see system block diagram). When the POR is asserted the soft start sequence starts (see soft start section).

ENABLE

The Enable features another level of flexibility for startup. The Enable has precise threshold which is internally monitored by Under-Voltage Lockout (UVLO) circuit. Therefore, the IR3846 will turn on only when the voltage at the Enable pin exceeds this threshold, typically, 1.2V.

If the input to the Enable pin is derived from the bus voltage by a suitably programmed resistive divider, it can be ensured that the IR3846 does not turn on until the bus voltage reaches the desired level as shown in Figure 4. Only after the bus voltage reaches or exceeds this level and voltage at the Enable pin exceeds its threshold, IR3846 will be enabled. Therefore, in addition to being a logic input pin to enable the IR3846, the Enable feature, with its precise threshold, also allows the user to implement an Under-Voltage Lockout for the bus voltage (P_{Vin}). It can help prevent the IR3846 from regulating at low P_{Vin} voltages that can cause excessive input current.

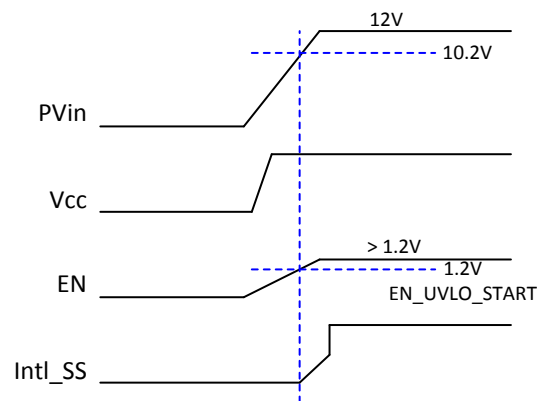

Figure 4: Normal Start up, device turns on when the bus voltage reaches 10.2V

A resistor divider is used at EN pin from P_{Vin} to turn on the device at 10.2V.

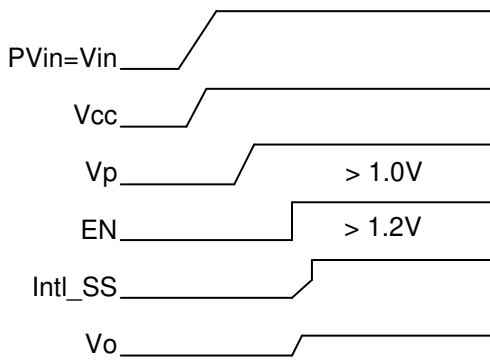

Figure 5: Recommended startup for Normal operation

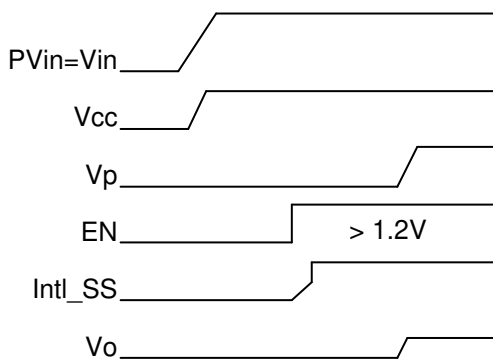

Figure 6: Recommended startup for sequencing operation (ratiometric or simultaneous)

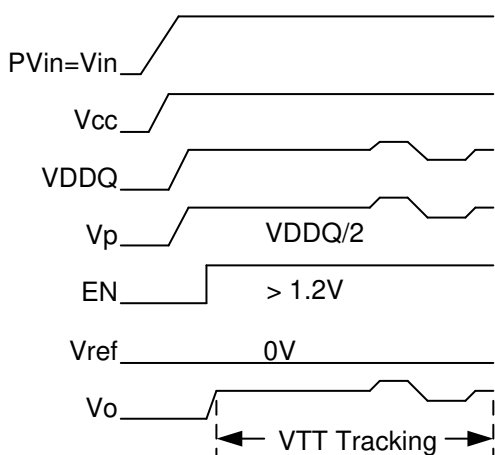

Figure 7: Recommended startup for memory tracking operation (Vtt-DDR)

Figure 5 shows the recommended startup sequence for the normal (non-tracking, non-sequencing) operation of IR3846, when Enable is used as a logic

input. In this operating mode Vref is left floating. Figure 6 shows the recommended startup sequence for sequenced operation of IR3846 with Enable used as logic input. Figure 7 shows the recommended startup sequence for tracking operation of IR3846 with Enable used as logic input. For this mode of operation, Vref should be connected to LGND.

PRE-BIAS STARTUP

IR3846 is able to start up into pre-charged output, which prevents oscillation and disturbances of the output voltage.

The output starts in asynchronous fashion and keeps the synchronous MOSFET (Sync FET) off until the first gate signal for control MOSFET (Ctrl FET) is generated. Figure 8 shows a typical Pre-Bias condition at start up. The sync FET always starts with a narrow pulse width (12.5% of a switching period) and gradually increases its duty cycle with a step of 12.5% until it reaches the steady state value. The number of these startup pulses for each step is 16 and it's internally programmed. Figure 9 shows the series of 16x8 startup pulses.

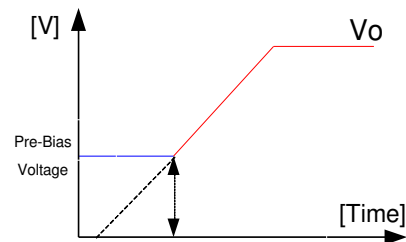

Figure 8: Pre-Bias startup

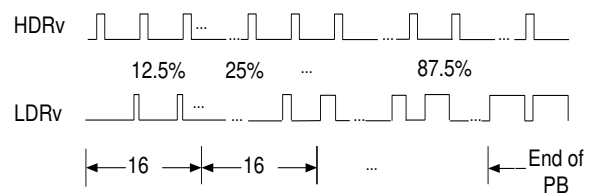

Figure 9: Pre-Bias startup pulses

SOFT-START

IR3846 has an internal digital soft-start to control the output voltage rise and to limit the current surge at the start-up. To ensure correct start-up, the soft-start sequence initiates when the Enable and VCC rise

above their UVLO thresholds and generate the Power On Ready (POR) signal. The internal soft-start (Intl_SS) signal linearly rises with the rate of 0.4mV/μs from 0V to 1.5V. Figure 10 shows the waveforms during soft start. The normal Vout startup time is fixed, and is equal to:

$$T_{start} = \frac{(0.75V - 0.15V)}{0.4mV / \mu S} = 1.5mS \quad (1)$$

During the soft start the over-current protection (OCP) and over-voltage protection (OVP) is enabled to protect the device for any short circuit or over voltage condition.

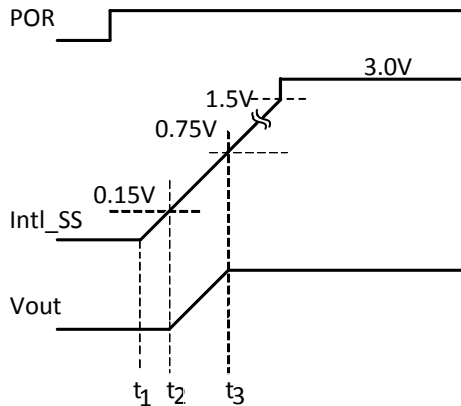

Figure 10: Theoretical operation waveforms during soft-start (non tracking / non sequencing)

OPERATING FREQUENCY

The switching frequency can be programmed between 300kHz – 1500kHz by connecting an external resistor from R_t pin to LGnd. Table 1 tabulates the oscillator frequency versus R_t.

Table 1: Switching Frequency(Fs) vs. External Resistor(R_t)

R _t (KΩ)	Freq (KHz)
80.6	300
60.4	400
48.7	500
39.2	600
34	700
29.4	800
26.1	900
23.2	1000
21	1100
19.1	1200
17.4	1300
16.2	1400
15	1500

SHUTDOWN

IR3846 can be shutdown by pulling the Enable pin below its 1.0V threshold. During shutdown the high side and the low side drivers are turned off.

OVER CURRENT PROTECTION

The Over Current (OC) protection is performed by sensing the inductor current through the R_{DS(on)} of the Synchronous MOSFET. This method enhances the converter's efficiency, reduces cost by eliminating a current sense resistor and any layout related noise issues. The Over Current (OC) limit can be set to one of three possible settings by floating the OCset pin, by pulling up the OCset pin to VCC, or pulling down the OCset pin to PGnd. The current limit scheme in the IR3846 uses an internal temperature compensated current source to achieve an almost constant OC limit over temperature.

Over Current Protection circuit senses the inductor current flowing through the Synchronous MOSFET. To help minimize false tripping due to noise and transients, inductor current is sampled for about 30 nS on the downward inductor current slope approximately 12.5% of the switching period before the inductor current valley. However, if the Synchronous MOSFET is on for less than 12.5% of the switching period, the current is sampled approximately 40nS after the start of the downward slope of the inductor current. When

the sampled current is higher than the OC Limit, an OC event is detected.

When an Over Current event is detected, the converter enters hiccup mode. Hiccup mode is performed by latching the OC signal and pulling the Intl_SS signal to ground for 20.48 mS (typ.). OC signal clears after the completion of hiccup mode and the converter attempts to return to the nominal output voltage using a soft start sequence. The converter will repeat hiccup mode and attempt to recover until the overload or short circuit condition is removed.

Because the IR3846 uses valley current sensing, the actual DC output current limit will be greater than OC limit. The DC output current is approximately half of peak to peak inductor ripple current above selected OC limit. OC Limit, inductor value, input voltage, output voltage and switching frequency are used to calculate the DC output current limit for the converter. Equation (2) to determine the approximate DC output current limit.

$$I_{OCP} = I_{LIMIT} + \frac{\Delta i}{2} \quad (2)$$

I_{OCP} = DC current limit hiccup point
 I_{LIMIT} = Current Limit Valley Point
 Δi = Inductor ripple current

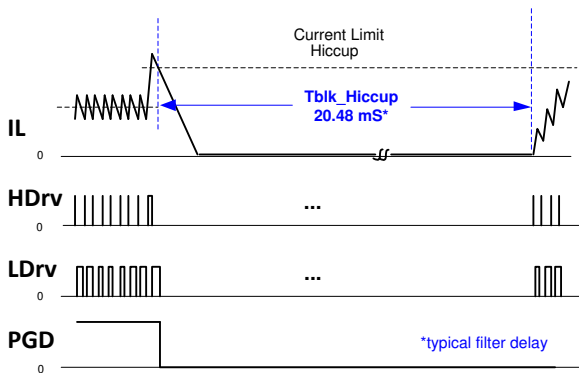

Figure 11: Timing Diagram for Current Limit Hiccup

THERMAL SHUTDOWN

Temperature sensing is provided inside IR3846. The trip threshold is typically 145°C. When trip threshold is exceeded, thermal shutdown turns off both MOSFETs and resets the internal soft start.

Automatic restart is initiated when the sensed temperature drops within the operating range. There is a 20°C hysteresis in the thermal shutdown threshold.

REMOTE VOLTAGE SENSING

True differential remote sensing in the feedback loop is critical to high current applications where the output voltage across the load may differ from the output voltage measured locally across an output capacitor at the output inductor, and to applications that require die voltage sensing.

The RS+ and RS- pins of the IR3846 form the inputs to a remote sense differential amplifier (RSA) with high speed, low input offset and low input bias current which ensure accurate voltage sensing and fast transient response in such applications.

The input range for the differential amplifier is limited to 1.5V below the VCC rail. Note that IR3846 incorporates a smart LDO which switches the VCC rail voltage depending on the loading. When determining the input range assume the part is in light load and using the lower VCC rail voltage.

There are two remote sense configurations that are usually implemented. Figure 12 shows a general remote sense (RS) configuration. This configuration allows the RSA to monitor output voltages above VCC. A resistor divider is placed in between the output and the RSA to provide a lower input voltage to the RSA inputs. Typically, the resistor divider is calculated to provide VREF (0.6V) across the RSA inputs which is then outputted to RSo. The input impedance of the RSA is 63 KOhms typically and should be accounted for when determining values for the resistor divider. To account for the input impedance, assume a 63 KOhm resistor in parallel to the lower resistor in the divider network. The compensation is then designed for 0.6V to match the RSo value.

Low voltage applications can use the second remote sense configuration. When the output voltage range is within the RSA input specifications, no resistor divider is needed in between the converter output and RSA. The second configuration is shown in Figure 13. The RSA is used as a unity gain buffer and compensation is determined normally.

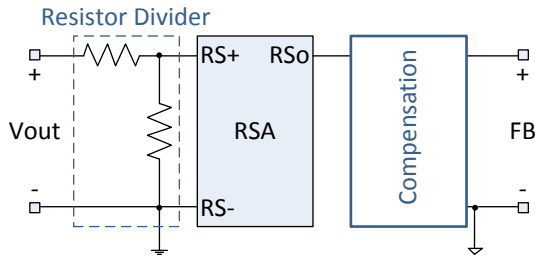

Figure 12: General Remote Sense Configuration

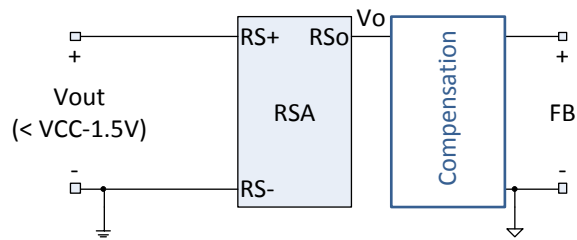

Figure 13: Remote Sense Configuration for Vout less than VCC-1.5V

EXTERNAL SYNCHRONIZATION

IR3846 incorporates an internal phase lock loop (PLL) circuit which enables synchronization of the internal oscillator to an external clock. This function is important to avoid sub-harmonic oscillations due to beat frequency for embedded systems when multiple point-of-load (POL) regulators are used. A multi-function pin, Rt/Sync, is used to connect the external clock. If the external clock is present before the converter turns on, Rt/Sync pin can be connected to the external clock signal solely and no other resistor is needed. If the external clock is applied after the converter turns on, or the converter switching frequency needs to toggle between the external clock frequency and the internal free-running frequency, an external resistor from Rt/Sync pin to LGnd is required to set the free-running frequency.

When an external clock is applied to Rt/Sync pin after the converter runs in steady state with its free-running frequency, a transition from the free-running frequency to the external clock frequency will happen. This transition is to gradually make the actual switching frequency equal to the external clock frequency, no matter which one is higher. When the external clock signal is removed from Rt/Sync pin, the switching frequency is also changed to free-running

gradually. In order to minimize the impact from these transitions to output voltage, a diode is recommended to add between the external clock and Rt/Sync pin. Figure 14 shows the timing diagram of these transitions.

An internal circuit is used to change the PWM ramp slope according to the clock frequency applied on Rt/Sync pin. Even though the frequency of the external synchronization clock can vary in a wide range, the PLL circuit keeps the ramp amplitude constant, requiring no adjustment of the loop compensation. P_{Vin} variation also affects the ramp amplitude, which will be discussed separately in Feed-Forward section.

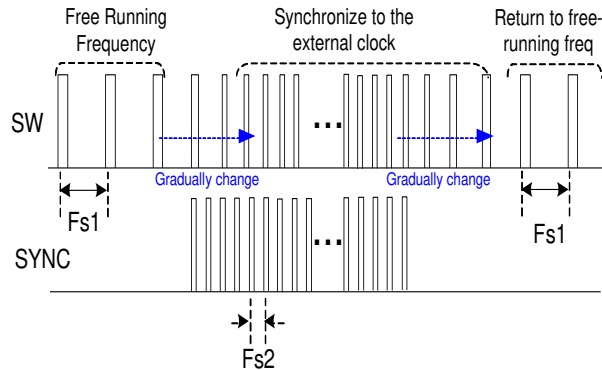

Figure 14: Timing Diagram for Synchronization to the external clock ($F_{s1} > F_{s2}$ or $F_{s1} < F_{s2}$)

FEED-FORWARD

Feed-Forward (F.F.) is an important feature, because it can keep the converter stable and preserve its load transient performance when P_{Vin} varies. The PWM ramp amplitude (V_{ramp}) is proportionally changed with P_{Vin} to maintain P_{Vin}/V_{ramp} almost constant throughout P_{Vin} variation range (as shown in Figure 15). The PWM ramp amplitude is adjusted to 0.15 of P_{Vin}. Thus, the control loop bandwidth and phase margin can be maintained constant. Feed-forward function can also minimize impact on output voltage from fast P_{Vin} change. F.F. is disabled when P_{Vin} < 6.2V and the PWM ramp is typically 0.9V. For P_{Vin} < 6.2V, P_{Vin} voltage should be accounted for when calculating control loop parameters.

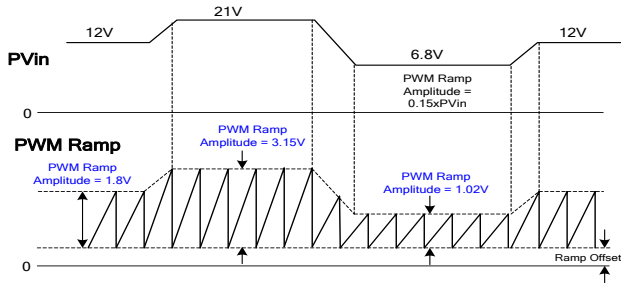

Figure 15: Timing Diagram for Feed-Forward (F.F.) Function

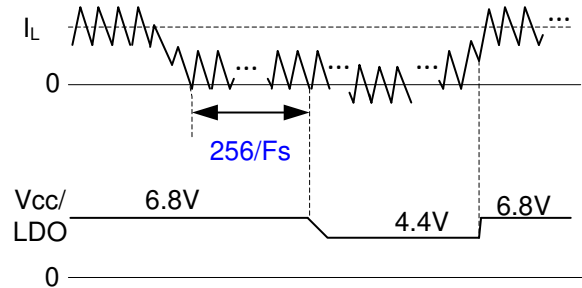

Figure 16: Time Diagram for Smart LDO

SMART LOW DROPOUT REGULATOR (LDO)

IR3846 has an integrated low dropout (LDO) regulator which can provide gate drive voltage for both drivers. In order to improve overall efficiency over the whole load range, LDO voltage is set to 6.8V (typ.) at mid- or heavy load condition to reduce $R_{ds(on)}$ and thus MOSFET conduction loss; and it is reduced to 4.4V (typ.) at light load condition to reduce gate drive loss.

The smart LDO selects its output voltage according to the load condition by sensing the inductor current (I_L). At light load condition, the inductor current can fall below zero as shown in Figure 16. A zero crossing comparator is used to detect when the inductor current falls below zero at the LDrv Falling Edge. If the comparator detects zero crossing events for 256 consecutive switching cycles, the smart LDO reduces its output to 4.4V. The LDO voltage will remain low until a zero crossing is not detected. Once a zero crossing is not detected, the counter is reset and LDO voltage returns to 6.8V. Figure 16 shows the timing diagram. Whenever the device turns on, LDO always starts with 6.8V, then goes to 4.4V / 6.8V depending upon the load condition. However, if only V_{in} is applied with Enable low, the LDO output is 4.4V.

Users can configure the IR3846 to use a single supply or dual supplies. Depending on the configuration used the PV_{in} , V_{in} and VCC pins are connected differently. Below several configurations are shown. In an internally biased configuration, the LDO draws from the V_{in} pin and provides a gate drive voltage, as shown in Figure 17. By connecting V_{in} and PV_{in} together as shown in the Figure 18, IR3846 is an internally biased single supply configuration that runs off a single supply.

IR3846 can also use an external bias to provide gate drive voltage for the drivers instead of the internal LDO. To use an external bias, connected V_{in} and VCC to the external bias. PV_{in} can use a separate rail as shown in Figure 19 or run off the same rail as V_{in} and VCC .

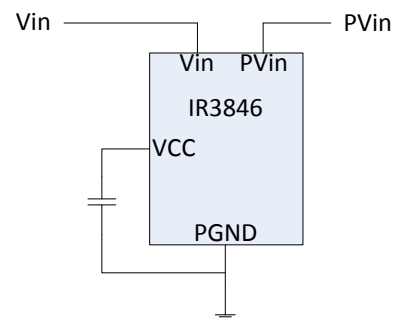

Figure 17: Internally Biased Configuration