



Chipsmall Limited consists of a professional team with an average of over 10 year of expertise in the distribution of electronic components. Based in Hongkong, we have already established firm and mutual-benefit business relationships with customers from,Europe,America and south Asia,supplying obsolete and hard-to-find components to meet their specific needs.

With the principle of “Quality Parts,Customers Priority,Honest Operation,and Considerate Service”,our business mainly focus on the distribution of electronic components. Line cards we deal with include Microchip,ALPS,ROHM,Xilinx,Pulse,ON,Everlight and Freescale. Main products comprise IC,Modules,Potentiometer,IC Socket,Relay,Connector.Our parts cover such applications as commercial,industrial, and automotives areas.

We are looking forward to setting up business relationship with you and hope to provide you with the best service and solution. Let us make a better world for our industry!



## Contact us

Tel: +86-755-8981 8866 Fax: +86-755-8427 6832

Email & Skype: info@chipsmall.com Web: www.chipsmall.com

Address: A1208, Overseas Decoration Building, #122 Zhenhua RD., Futian, Shenzhen, China



## SELF-OSCILLATING HALF BRIDGE

### Features

- Output Power MOSFETs in half-bridge configuration
- High side gate drive designed for bootstrap operation
- Bootstrap diode integrated into package (HD type)
- Accurate timing control for both Power MOSFETs
  - Matched delay to get 50% duty cycle
  - Matched deadtime of 1.2 $\mu$ s
- Internal oscillator with programmable frequency

$$f = \frac{1}{1.4 \times (R_T + 75\Omega) \times C_T}$$

- 15.6V Zener clamped Vcc for offline operation
- Half-bridge output is out of phase with R<sub>T</sub>
- Micropower startup

### Description

The IR51H(D)XXX are complete high voltage, high speed, self-oscillating half-bridge circuits. Proprietary HVIC and latch immune CMOS technologies, along with the HEXFET® power MOSFET technology, enable ruggedized single package construction. The front-end features a programmable oscillator which functions similar to the CMOS 555 timer. The supply to the control circuit has a zener clamp to simplify offline operation. The output features two HEXFETs in a half-bridge configuration with an internally set deadtime designed for minimum cross-conduction in the half-bridge. Propagation delays for the high and low side

### Product Summary

V <sub>IN</sub> (max)	250V (IR51H(D)224) 400V (IR51H(D)310) 500V (IR51H(D)420)
Duty Cycle	50%
Deadtime	1.2 $\mu$ s
R <sub>ds(on)</sub>	1.1W (IR51H(D)224) 3.0W (IR51H(D)310) 3.6W (IR51H(D)420)
P <sub>D</sub> (T <sub>A</sub> = 25°C)	2.0W

### Package

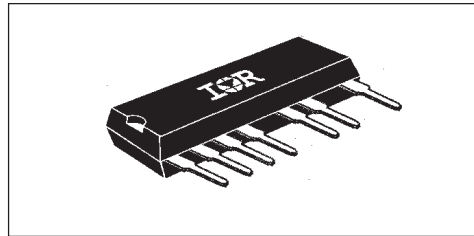

power MOSFETs are matched to simplify use in 50% duty cycle applications. The device can operate up to 500 volts.

### Typical Connection

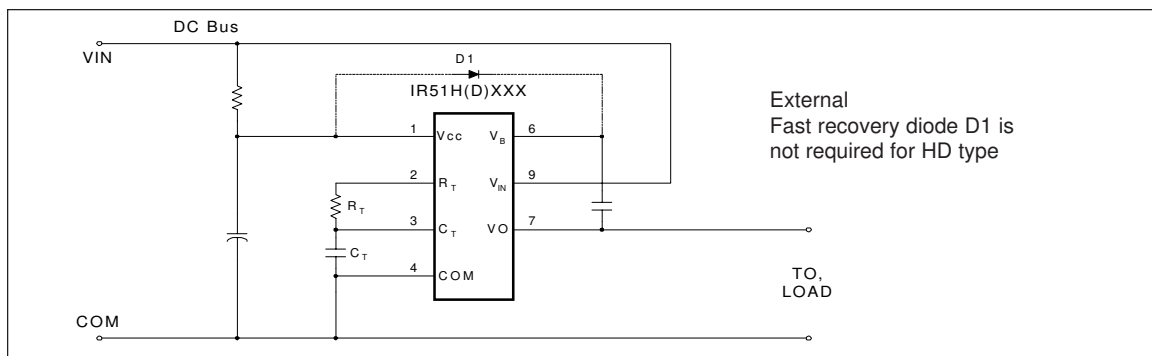

**IR51H(D)224**  
**IR51H(D)320**  
**IR51H(D)420**

**Absolute Maximum Ratings**

Absolute maximum ratings indicate sustained limits beyond which damage to the device may occur. All voltage parameters are absolute voltages referenced to COM, all currents are defined positive into any lead. The thermal resistance and power dissipation ratings are measured under board mounted and still air conditions.

Symbol	Definition	Minimum	Maximum	Units
V <sub>IN</sub>	High voltage supply	-224	- 0.3	250
		-320	- 0.3	400
		-420	- 0.3	500
V <sub>B</sub>	High side floating supply	V <sub>o</sub> - 0.3	V <sub>o</sub> +2.5	V
V <sub>O</sub>	Half-bridge output	-0.3	V <sub>IN</sub> + 0.3	
V <sub>RT</sub>	R <sub>T</sub> voltage	- 0.3	V <sub>cc</sub> + 0.3	
V <sub>CT</sub>	C <sub>T</sub> voltage	- 0.3	V <sub>cc</sub> + 0.3	
I <sub>cc</sub>	Supply current (note 1)	—	25	mA
I <sub>RT</sub>	R <sub>T</sub> output current	- 5	5	
dV/dt	Peak diode recovery	—	3.5	V/ns
P <sub>D</sub>	Package power dissipation @ T <sub>A</sub> ≤ +25°C	—	2.00	W
Rth <sub>JA</sub>	Thermal resistance, junction to ambient	—	60	°C/W
T <sub>J</sub>	Junction temperature	-55	150	°C
T <sub>S</sub>	Storage temperature	-55	150	
T <sub>L</sub>	Lead temperature (soldering, 10 seconds)	—	300	

**NOTE 1:**

This IC contains a zener clamp structure between V<sub>CC</sub> and COM which has a nominal breakdown voltage of 15.6V. Please note that this supply pin should not be driven by a DC, low impedance power source greater than the V<sub>CLAMP</sub> specified in the Electrical Characteristics Section

### Recommended Operating Conditions

The input/output logic timing diagram is shown in figure 1. For proper operation, the device should be used within the recommended conditions.

Symbol	Definition	Minimum	Maximum	Units	
$V_B$	High side floating supply absolute voltage	$V_O + 10$	$V_O + V_{clamp}$	V	
$V_{IN}$	High voltage supply	-224	—		250
		-320	—		400
		-420	—	500	
$V_O$	Half-bridge output voltage	-3.0 (note 2)	$V_{IN}$		
$I_D$	Continuous drain current ( $T_A = 25^\circ\text{C}$ )  ( $T_A = 85^\circ\text{C}$ )	-224	—	1.1	A
		-320	—	0.9	
		-420	—	0.7	
		-224	—	0.7	
		-320	—	0.6	
		-420	—	0.5	
$I_{CC}$	Supply current	(note 3)	5	mA	
$T_A$	Ambient temperature	-40	125	$^\circ\text{C}$	

**NOTE 2:**

Care should be taken to avoid switching conditions where the  $V_S$  node flies inductively below ground by more than 5V.

**NOTE 3:**

Enough current should be supplied to the  $V_{CC}$  lead of the IC to keep the internal 15.6V zener diode clamping the voltage at this lead.

### Dynamic Electrical Characteristics

$V_{BIAS} (V_{CC}, V_{BS}) = 12\text{V}$ ,  $T_A = 25^\circ\text{C}$  unless otherwise specified.

Symbol	Definition	Min.	Typ.	Max.	Units	Test Conditions
$t_{rr}$	Reverse recovery time (MOSFET body diode)	-224	—	200	ns	$I_F = 1.1\text{A}$ $I_F = 900\text{mA}$ $I_F = 700\text{mA}$ $di/dt = 100$
		-320	—	270		
		-420	—	240		
$Q_{rr}$	Reverse recovery charge (MOSFET body diode)	-224	—	0.7	$\mu\text{C}$	$I_F = 1.1\text{A}$ $I_F = 900\text{mA}$ $I_F = 700\text{mA}$ $A/\mu\text{s}$
		-320	—	0.6		
		-420	—	0.5		
D	$R_T$ duty cycle	—	50	—	%	$f_{osc} = 20\text{ kHz}$



**IR51H(D)224**  
**IR51H(D)320**  
**IR51H(D)420**

International  
**IR** Rectifier

**Static Electrical Characteristics**

$V_{BIAS} (V_{CC}, V_B) = 12V, T_A = 25^\circ C$  unless otherwise specified.

Symbol	Definition	Min.	Typ.	Max.	Units	Test Conditions	
$V_{CCUV+}$	$V_{CC}$ supply undervoltage positive going threshold	—	8.4	—	V		
$V_{CCUV-}$	$V_{CC}$ supply undervoltage negative going threshold	—	8.0	—	V		
$I_{QCC}$	Quiescent $V_{CC}$ supply current	—	300	—	$\mu A$	$V_{CC} > V_{CCUV}$	
$V_{CLAMP}$	$V_{CC}$ zener shunt clamp voltage	—	15.6	—	V	$I_{CC} = 5mA$	
$I_{QBS}$	Quiescent $V_{BS}$ supply current	—	30	—	$\mu A$	$V_B = V_{IN} = 500V$	
$I_{OS}$	Offset supply leakage current	—	—	50			
$f_{OSC}$	Oscillator frequency	—	20	—	kHz	$R_T = 35.7 k\Omega$ $C_T = 1 nF$	
		—	100	—		$R_T = 7.04 k\Omega$ $C_T = 1 nF$	
$I_{CT}$	$C_T$ input current	—	0.001	1.0	$\mu A$		
$V_{CTUV}$	$C_T$ undervoltage lockout	—	100	—	mV	Note 2	
$V_{RT+}$	$R_T$ high level output voltage, $V_{CC} - R_T$	—	20	—		$I_{RT} = 100\mu A$ $I_{RT} = -1mA$	
$V_{RT-}$	$R_T$ low level output voltage	—	20	—		$I_{RT} = 100\mu A$ $I_{RT} = -1mA$	
		—	200	—		$I_{RT} = 100\mu A$	
$V_{RTUV}$	$R_T$ undervoltage lockout, $V_{CC} - R_T$	—	100	—			
$V_{CT+}$	2/3 $V_{CC}$ threshold	—	8.0	—	kHz		
$V_{CT-}$	1/3 $V_{CC}$ threshold	—	4.0	—			
$R_{ds(on)}$	Static-drain-to-source on-resistance	-224	—	1.1	$\Omega$	$I_F = 1.1A$ $I_F = 900mA$ $I_F = 700mA$	di/dt =100 A/ $\mu s$
		-320	—	1.8			
		-420	—	3.0			
$V_{SD}$	Diode forward voltage	-224	—	0.85	V	$I_F = 1.1A$ $I_F = 900mA$ $I_F = 700mA$	
		-320	—	0.7			
		-420	—	0.8			

### Functional Block Diagram

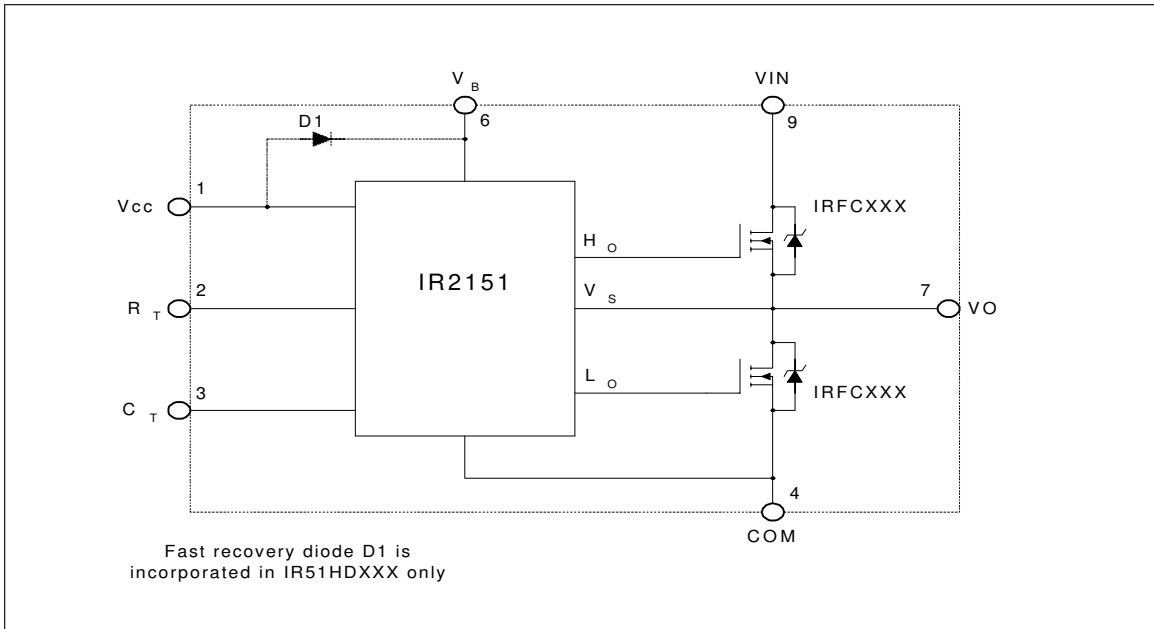

### Lead Definitions

Symbol	Lead Description
V <sub>CC</sub>	Logic and internal gate drive supply voltage. An internal zener clamp diode at 15.6 V nominal is included to allow the V <sub>CC</sub> to be current fed directly from V <sub>IN</sub> typically by means of a high value resistor.
R <sub>T</sub>	Oscillator timing resistor output; a resistor is connected from R <sub>T</sub> to C <sub>T</sub> . R <sub>T</sub> is out of phase with the half-bridge output (VO).
C <sub>T</sub>	Oscillator timing capacitor input; a capacitor is connected from C <sub>T</sub> to COM in order to program the oscillator frequency according to the following equation: $f = \frac{1}{1.4 \times (R_T + 75\Omega) \times C_T}$ C <sub>T</sub> PIN also invokes shutdown function (see note 2) where 75Ω is the effective impedance of the R <sub>T</sub> output stage.
V <sub>B</sub>	High side gate drive floating supply. For bootstrap operation a high voltage fast recovery diode is needed to feed from V <sub>CC</sub> to V <sub>B</sub> . (HD type circuits incorporate this diode).
V <sub>IN</sub>	High voltage supply
VO	Half Bridge output
COM	Logic and low side of half bridge return

IR51H(D)224  
 IR51H(D)320  
 IR51H(D)420

International  
**IR** Rectifier

**Lead Assignments**

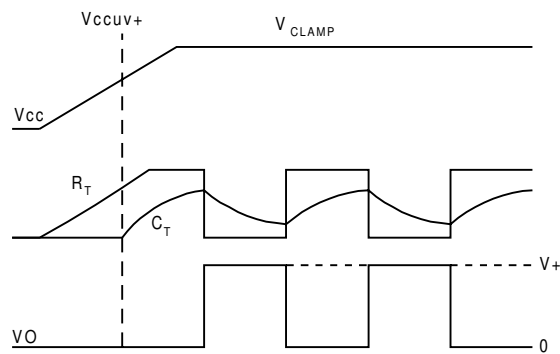
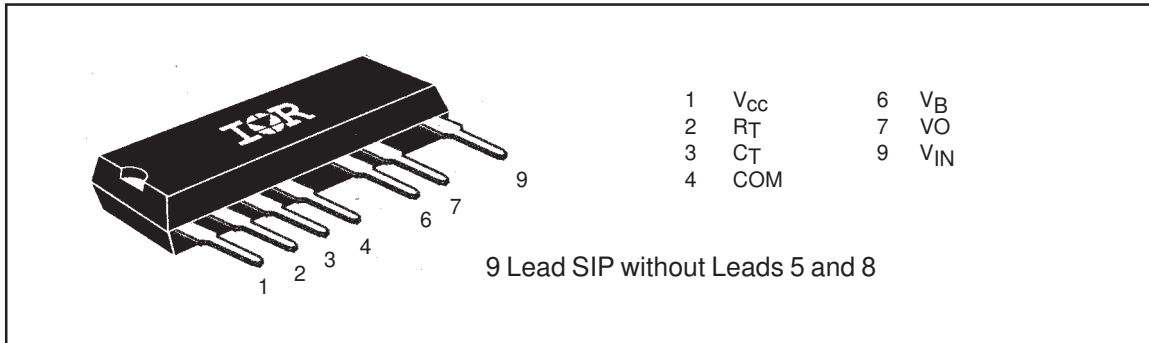

Figure 1. Input/Output Timing Diagram

