



Chipsmall Limited consists of a professional team with an average of over 10 year of expertise in the distribution of electronic components. Based in Hongkong, we have already established firm and mutual-benefit business relationships with customers from,Europe,America and south Asia,supplying obsolete and hard-to-find components to meet their specific needs.

With the principle of “Quality Parts,Customers Priority,Honest Operation,and Considerate Service”,our business mainly focus on the distribution of electronic components. Line cards we deal with include Microchip,ALPS,ROHM,Xilinx,Pulse,ON,Everlight and Freescale. Main products comprise IC,Modules,Potentiometer,IC Socket,Relay,Connector.Our parts cover such applications as commercial,industrial, and automotives areas.

We are looking forward to setting up business relationship with you and hope to provide you with the best service and solution. Let us make a better world for our industry!



## Contact us

Tel: +86-755-8981 8866 Fax: +86-755-8427 6832

Email & Skype: info@chipsmall.com Web: www.chipsmall.com

Address: A1208, Overseas Decoration Building, #122 Zhenhua RD., Futian, Shenzhen, China



## IR53H(D)420

### SELF-OSCILLATING HALF BRIDGE

#### Features

- Output power MOSFETs in half-bridge configuration
- High side gate drive designed for bootstrap operation
- Bootstrap diode integrated into package (HD type)
- Tighter initial deadtime control
- Low temperature coefficient deadtime
- 15.6V zener clamped V<sub>CC</sub> for offline operation
- Half-bridge output is out of phase with R<sub>T</sub>
- True micropower startup
- Shutdown feature (1/6th V<sub>CC</sub>) on C<sub>T</sub> lead
- Increased undervoltage lockout hysteresis (1V<sub>olt</sub>)
- Lower power level-shifting circuit
- Lower di/dt gate drive for better noise immunity
- Excellent latch immunity on all inputs and outputs
- ESD protection on all leads
- Constant V<sub>O</sub> pulse width at startup
- Heatsink package version (P2 type)

#### Description

The IR53H(D)420 are complete high voltage, high speed, self-oscillating half-bridge circuits. Proprietary HVIC and latch immune CMOS technologies, along with the HEXFET® power MOSFET technology, enable ruggedized single package construction. The front-end features a programmable oscillator which functions similar to the CMOS 555 timer. The supply to the control circuit has a zener clamp to simplify offline operation. The output features two HEXFETs in a half-bridge configuration with an internally set deadtime designed for minimum cross-conduction in the half-bridge. Propagation delays for the high and low side power MOSFETs are matched to simplify use in 50% duty cycle applications. The device can operate up to the V<sub>IN</sub> (max) rating.

#### Product Summary

V <sub>IN</sub> (max)	500V
Duty Cycle	50%
Deadtime (type.)	1.2μs
R <sub>ds(on)</sub>	3.0Ω
P <sub>D</sub> (T <sub>A</sub> = 25°C)	2.0W or 3.0W

#### Package

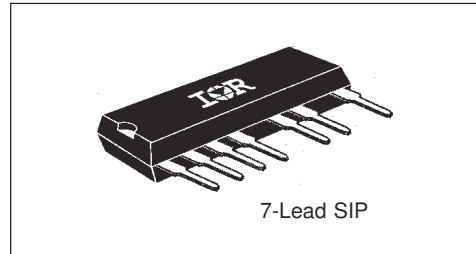

#### Typical Connection

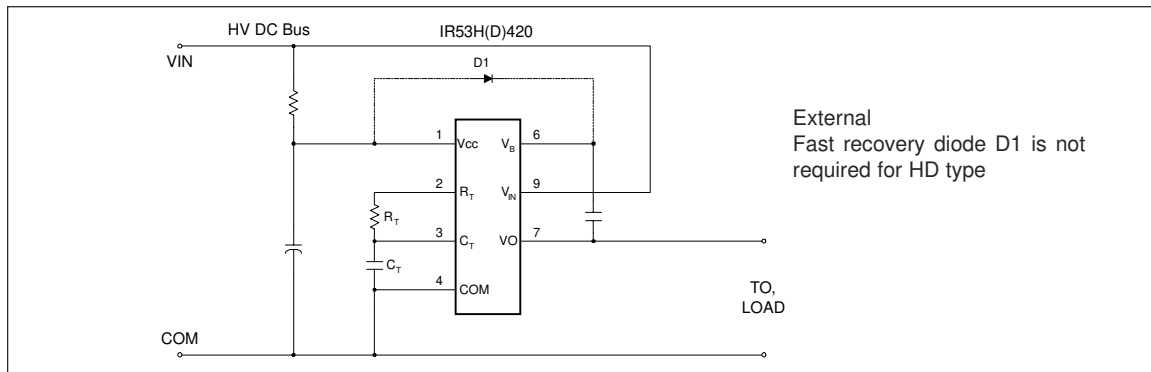

## Absolute Maximum Ratings

Absolute maximum ratings indicate sustained limits beyond which damage to the device may occur. All voltage parameters are absolute voltages referenced to COM, unless stated otherwise. All currents are defined positive into any lead. The thermal resistance and power dissipation ratings are measured under board mounted and still air conditions.

Symbol	Definition	Minimum	Maximum	Units	
$V_{IN}$	High voltage supply	- 0.3	500	V	
$V_B$	High side floating supply	$V_O - 0.3$	$V_O + 25$		
$V_O$	Half-bridge output	-0.3	$V_{IN} + 0.3$		
$V_{RT}$	$R_T$ voltage	- 0.3	$V_{CC} + 0.3$		
$V_{CT}$	$C_T$ voltage	- 0.3	$V_{CC} + 0.3$		
$I_{CC}$	Supply current (note 1)	—	25	mA	
$I_{RT}$	$R_T$ output current	- 5	5	W	
dV/dt	Peak diode recovery	—	3.50		V/ns
$P_D$	Package power dissipation @ $T_A \leq +25^\circ\text{C}$	—	2		
		-P2	3		
$R_{thJA}$	Thermal resistance, junction to ambient	—	60	$^\circ\text{C/W}$	
		-P2	40		
$R_{thJC}$	Thermal resistance, junction to case (heatsink)	-P2	20		
$T_J$	Junction temperature	-55	150	$^\circ\text{C}$	
$T_S$	Storage temperature	-55	150		
$T_L$	Lead temperature (soldering, 10 seconds)	—	300		

### NOTE 1:

This IC contains a zener clamp structure between  $V_{CC}$  and COM which has a nominal breakdown voltage of 15.6V. Please note that this supply pin should not be driven by a DC, low impedance power source greater than the  $V_{CLAMP}$  specified in the Electrical Characteristics Section

Recommended Component Values

Symbol	Definition	Minimum	Maximum	Units
$R_T$	Timing resistor value	10	—	$k\Omega$
$C_T$	$C_T$ pin capacitor value	330	—	$\mu F$

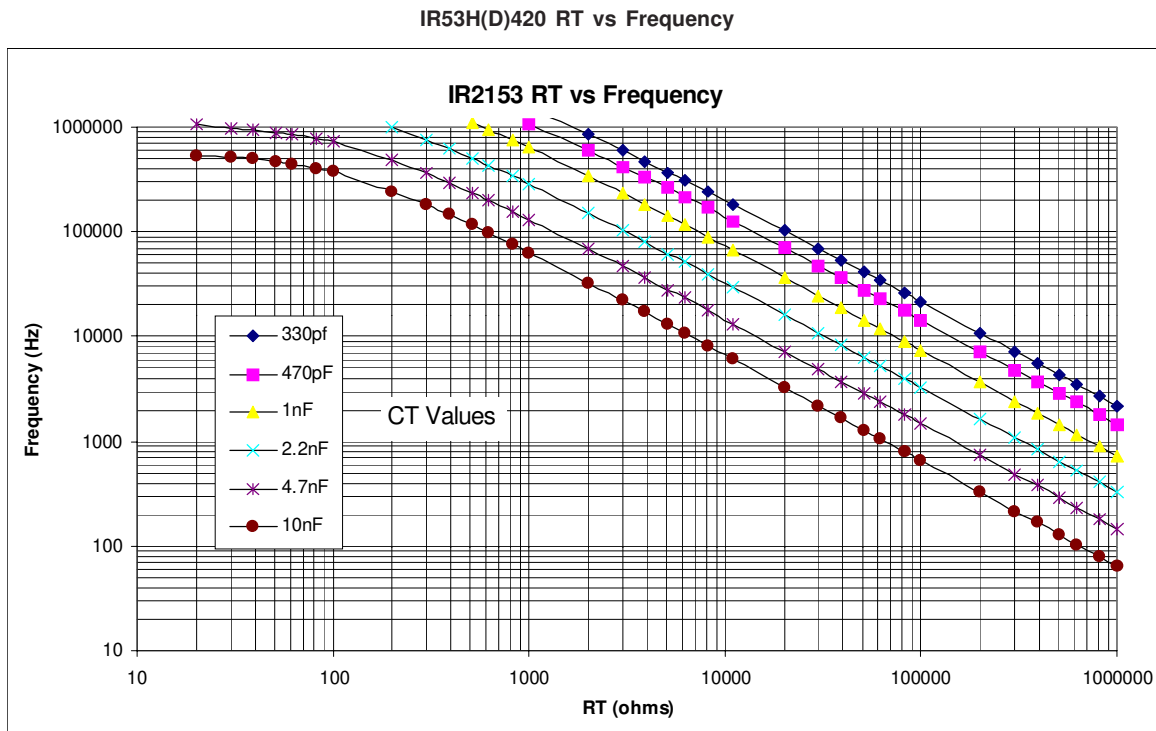



## Recommended Operating Conditions

The input/output logic timing diagram is shown in figure 1. For proper operation, the device should be used within the recommended conditions.

Symbol	Definition	Minimum	Maximum	Units
$V_B$	High side floating supply absolute voltage	$V_O + 10$	$V_O + V_{clamp}$	V
$V_{IN}$	High voltage supply	—	500	
$V_O$	Half-bridge output voltage	-3.0 (note 3)	500	
$I_D$	Continuous drain current ( $T_A = 25^\circ\text{C}$ )	—	0.7	A
	-P2	—	0.85	
	( $T_A = 85^\circ\text{C}$ )	—	0.5	
	-P2	—	0.6	
	( $T_C = 25^\circ\text{C}$ ) -P2	—	1.2	
$I_{CC}$	Supply current	(note 3)	5	mA
$T_A$	Ambient temperature	-40	125	$^\circ\text{C}$

### NOTE 2:

Care should be taken to avoid switching conditions where the  $V_S$  node flies inductively below ground by more than 5V.

### NOTE 3:

Enough current should be supplied to the  $V_{CC}$  lead of the IC to keep the internal 15.6V zener diode clamping the voltage at this lead.

## Electrical Characteristics

$V_{BIAS}$  ( $V_{CC}$ ,  $V_{BS}$ ) = 12V,  $C_T = 1$  nF and  $T_A = 25^\circ\text{C}$  unless otherwise specified. The  $V_{IN}$ ,  $V_{TH}$  and  $I_{IN}$  parameters are referenced to COM.

MOSFET Characteristics						
Symbol	Definition	Min.	Typ.	Max.	Units	Test Conditions
$t_{rr}$	Reverse recovery time (MOSFET body diode)	—	240	—		$I_F = 700\text{mA}$ $di/dt = 100$ $\text{A}/\mu\text{s}$
$Q_{rr}$	Reverse recovery charge (MOSFET body diode)	—	0.5	—	$\mu\text{C}$	
$R_{ds(on)}$	Static drain-to-source on resistance	—	3.0	—	$\Omega$	
$V_{SD}$	Diode forward voltage	—	0.8	—	V	
Dynamic Characteristics						
Symbol	Definition	Min.	Typ.	Max.	Units	Test Conditions
D	RT duty cycle	—	50	—	%	fosc = 20 kHz
tsd	Shutdown propagation delay	—	660	—	nsec	

## Electrical Characteristics

$V_{BIAS}$  ( $V_{CC}$ ,  $V_{BS}$ ) = 12V,  $C_T$  = 1 nF and  $T_A$  = 25°C unless otherwise specified. The  $V_{IN}$ ,  $V_{TH}$  and  $I_{IN}$  parameters are referenced to COM.

Low Voltage Supply Characteristics						
Symbol	Definition	Min.	Typ.	Max.	Units	Test Conditions
$V_{CCUV+}$	Rising $V_{CC}$ undervoltage lockout threshold	8.1	9.0	9.9	V	
$V_{CCUV-}$	Falling $V_{CC}$ undervoltage lockout threshold	7.2	8.0	8.8		
$V_{CCUVH}$	$V_{CC}$ undervoltage lockout Hysteresis	0.5	1.0	1.5		
$I_{QCCUV}$	Micropower startup $V_{CC}$ supply current	—	75	150	$\mu$ A	$V_{CC} \leq V_{CCUV-}$
$I_{QCC}$	Quiescent $V_{CC}$ supply current	—	500	950		
$V_{CLAMP}$	$V_{CC}$ zener clamp voltage	14.4	15.6	16.8	V	$I_{CC} = 5mA$
Floating Supply Characteristics						
Symbol	Definition	Min.	Typ.	Max.	Units	Test Conditions
$I_{QBSUV}$	Micropower startup $V_{BS}$ supply current	—	0	10	$\mu$ A	$V_{CC} \leq V_{CCUV-}$
$I_{QBS}$	Quiescent $V_{BS}$ supply current	—	30	50		
$V_{BSMIN}$	Minimum required $V_{BS}$ voltage for proper functionality from $R_T$ to HO	—	4.0	5.0	V	$V_{CC} = V_{CCUV+} + 0.1V$
$I_{OS}$	Offset supply leakage current	—	—	50	$\mu$ A	$V_B = V_S = 600V$
$V_F$	Bootstrap diode forward voltage (IR2153D)	0.5	—	1.0	V	$I_F = 250mA$
Oscillator I/O Characteristics						
Symbol	Definition	Min.	Typ.	Max.	Units	Test Conditions
$f_{osc}$	Oscillator frequency	19.4	20	20.6	kHz	$R_T = 36.9k\Omega$
		94	100	106		$R_T = 7.43k\Omega$
$d$	$R_T$ pin duty cycle	48	50	52	%	$f_o < 100kHz$
$I_{CT}$	$C_T$ pin current	—	0.001	1.0	$\mu$ A	
$I_{CTUV}$	UV-mode $C_T$ pin pulldown current	0.30	0.70	1.2	mA	$V_{CC} = 7V$
$V_{CT+}$	Upper $C_T$ ramp voltage threshold	—	8.0	—	V	
$V_{CT-}$	Lower $C_T$ ramp voltage threshold	—	4.0	—		
$V_{CTSD}$	$C_T$ voltage shutdown threshold	1.8	2.1	2.4		
$V_{RT+}$	High-level $R_T$ output voltage, $V_{CC} - V_{RT}$	—	10	50	mV	$I_{RT} = 100\mu A$
$V_{RT-}$	Low-level $R_T$ output voltage	—	100	300		$I_{RT} = 1mA$
		—	10	50		$I_{RT} = 100\mu A$
$V_{RTUV}$	UV-mode $R_T$ output voltage	—	100	300		$I_{RT} = 1mA$
		—	0	100		$V_{CC} \leq V_{CCUV-}$
$V_{RTSD}$	SD-Mode $R_T$ output voltage, $V_{CC} - V_{RT}$	—	10	50		$I_{RT} = 100\mu A,$ $V_{CT} = 0V$
		—	10	300	$I_{RT} = 1mA,$ $V_{CT} = 0V$	

## Functional Block Diagram

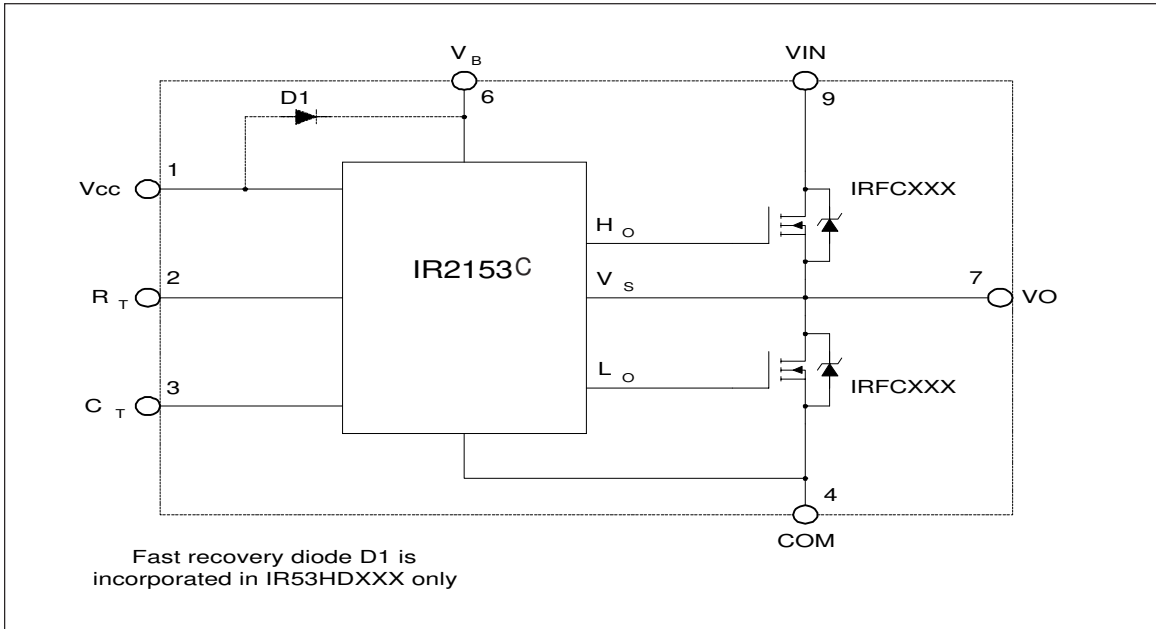

### Lead Assignments

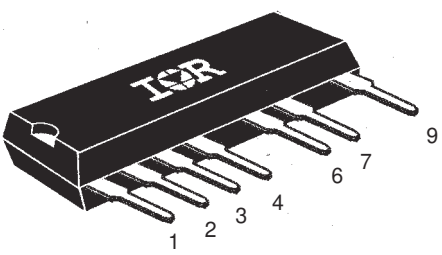

1	$V_{CC}$	6	$V_B$
2	$R_T$	7	$V_O$
3	$C_T$	9	$V_{IN}$
4	COM		

9 Lead SIP without Leads 5 and 8

### Lead Definitions

Symbol	Lead Description
$V_{CC}$	Logic and internal gate drive supply voltage.
$R_T$	Oscillator timing resistor output
$C_T$	Oscillator timing capacitor input
$V_B$	High side gate drive floating supply.
$V_{IN}$	High voltage supply
$V_O$	Half Bridge output
COM	Logic and low side of half bridge return

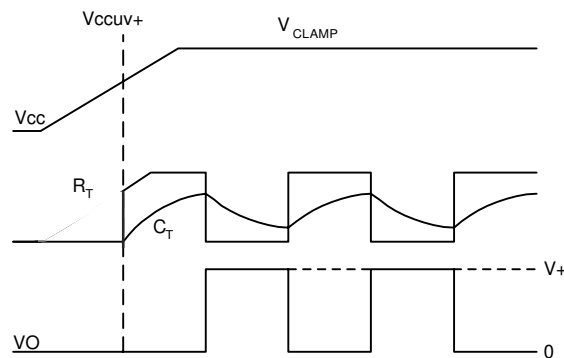

Figure 1. Input/Output Timing Diagram



# IR53H(D)420

International  
**IR** Rectifier

## Case Outline - 7 pin

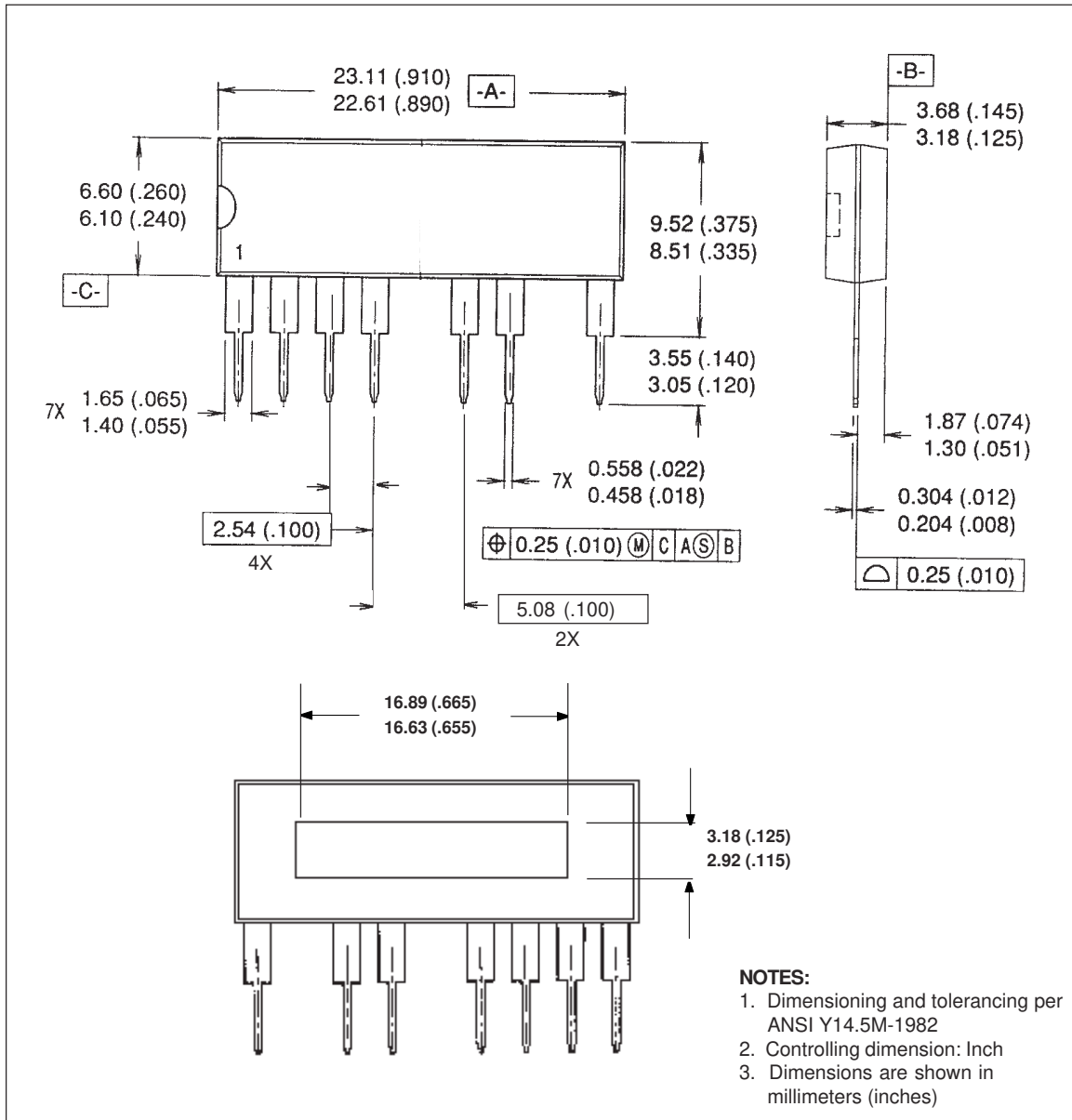

**WORLD HEADQUARTERS:** 233 Kansas St., El Segundo, California 90245 Tel: (310) 252-7105  
<http://www.irf.com> Data and specifications subject to change without notice. 8/19/2003