



Chipsmall Limited consists of a professional team with an average of over 10 year of expertise in the distribution of electronic components. Based in Hongkong, we have already established firm and mutual-benefit business relationships with customers from,Europe,America and south Asia,supplying obsolete and hard-to-find components to meet their specific needs.

With the principle of “Quality Parts,Customers Priority,Honest Operation,and Considerate Service”,our business mainly focus on the distribution of electronic components. Line cards we deal with include Microchip,ALPS,ROHM,Xilinx,Pulse,ON,Everlight and Freescale. Main products comprise IC,Modules,Potentiometer,IC Socket,Relay,Connector.Our parts cover such applications as commercial,industrial, and automotives areas.

We are looking forward to setting up business relationship with you and hope to provide you with the best service and solution. Let us make a better world for our industry!



Contact us

Tel: +86-755-8981 8866 Fax: +86-755-8427 6832

Email & Skype: info@chipsmall.com Web: www.chipsmall.com

Address: A1208, Overseas Decoration Building, #122 Zhenhua RD., Futian, Shenzhen, China



INTELLIGENT HIGH SIDE MOSFET POWER SWITCH

Features

- PWM current limit for short circuit protection
- Over-temperature protection
- Active output negative clamp
- Reverse battery protection for logic circuit
- Broken ground protection
- Short to V_{CC} protection
- Low noise charge pump
- Sleep mode supply current
- 4kV ESD protection on all leads
- Logic ground isolated from power ground

General Description

The IR6220 is a 5 terminal monolithic HIGH SIDE SWITCH with built in short circuit, over-temperature, ESD protections, inductive load turn off capability and diagnostic feedback.

The on-chip protection circuit goes into PWM mode, limiting the average current during short circuit if the drain current exceeds 10A. The protection circuit latches off the high side switch if the junction temperature exceeds 170°C and latches on after the junction temperature falls by 10°C. The V_{CC} (drain) to out (source) voltage is actively clamped at 55V, improving its performance during turn off with inductive loads.

The on-chip charge pump high side driver stage is floating and referenced to the source of the Power MOSFET. Thus the logic to power ground isolation can be as high as 50V. This allows operation with larger offset as well as controlling the switch during load energy recirculation or regeneration.

A diagnostic pin is provided for status feedback of short circuit, over temperature and open load detection.

Product summary

| | |
|--------------|---------------|
| $V_{CC(op)}$ | 5-50V |
| $R_{DS(on)}$ | 100m Ω |
| I_{lim} | 10A |
| $T_{j(sd)}$ | 170°C |
| E_{av} | 200mJ |

Applications

- Solenoid driver
- Programmable logic controller

Truth Table

| Condition | In | Out | Dg |
|------------------|----|------------------------------|----|
| Normal | H | H | H |
| Normal | L | L | L |
| Output Open | H | H | H |
| Output Open | L | H | H |
| Shorted Output | H | Current-Limiting PWM Mode | L |
| Shorted Output | L | L | L |
| Over-Temperature | H | L | L |
| Over-Temperature | L | L | L |

Block Diagram

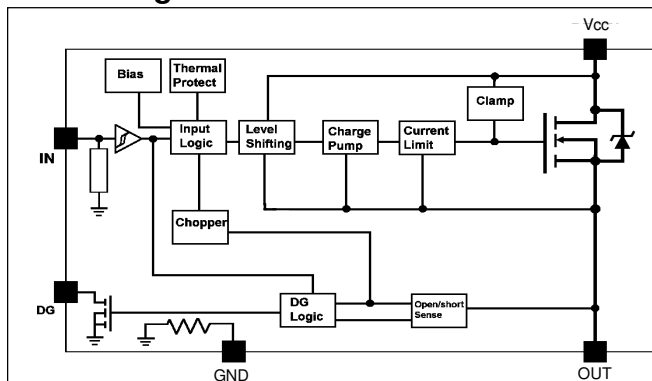

Available Packages

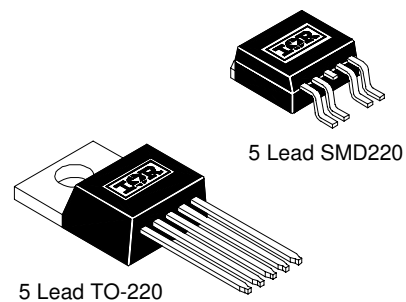

Absolute Maximum Ratings

Absolute maximum ratings indicate sustained limits beyond which damage to the device may occur.
($T_C = 25^\circ\text{C}$ unless otherwise specified.)

| Symbol | Parameter | Min. | Max. | Units | Test Conditions |
|---------------------|--------------------------------------------|---------------------|----------------------|-------|--------------------------|
| V _{cc} | Supply voltage permanent | -0.3 | 50 | V | For 10 seconds, (1) |
| | reverse | -16 | — | | |
| V _{offset} | Logic to power ground offset | V _{cc} -50 | V _{cc} +0.3 | | |
| V _{in} | Input voltage | -0.3 | 30 | | |
| I _{in} | Input current | — | 10 | mA | |
| V _{out} | Output voltage | V _{cc} -50 | V _{cc} +0.3 | V | |
| I _{out} | Output current | — | self-limited | A | |
| V _{dg} | Diagnostic output voltage | -0.3 | 30 | V | |
| I _{dg} | Diagnostic output current | — | 10 | mA | |
| E _{av} | Repetitive avalanche energy | — | 200 | mJ | I = 2A (2) |
| ESD1 | Electrostatic discharge (Human Body Model) | — | 4000 | V | C = 100 pF, R = 1500Ω |
| ESD2 | Electrostatic discharge (Machine Model) | — | 1000 | V | C = 200 pF, R = 0Ω |
| PD | Power dissipation | — | 28 | W | T _{case} = 25°C |
| T _{Jop} | Operating junction temperature range | -40 | 150 | °C | |
| T _{Stg} | Storage temperature range | -40 | 150 | | |
| T _L | Lead temperature (soldering, 10 seconds) | — | 300 | | |

NOTES: (1) with 15kΩ resistors in input and diagnostic

(2) maximum frequency depends on heatsink (rectangular waveform)

Static Electrical Characteristics

($T_C = 25^\circ\text{C}$ unless otherwise specified.)

| Symbol | Parameter | Min. | Typ. | Max. | Units | Test Conditions |
|---------------------|-------------------------------------|------|------|------|-------|---------------------------------------------|
| V _{ccop} | Operating voltage range | 5 | — | 35 | V | |
| I _{ccoff} | Sleep mode supply current | — | 40 | — | μA | V _{cc} =24V, V _{in} = 0V |
| I _{ccon} | Supply current (average) | — | 3 | — | mA | V _{in} = 5V |
| I _{ccac} | Supply current (AC RMS) | — | 20 | — | μA | V _{in} = 5V |
| V _{ih} | High level input threshold voltage | — | 2 | 2.5 | V | |
| V _{il} | Low level input threshold voltage | 1 | 1.8 | — | | |
| I _{ion} | On-state input current | 10 | — | 70 | μA | V _{in} = 3.5V |
| I _{loff} | Off-state input current | 1 | — | 30 | | V _{in} = 0.4V |
| I _{oh} | Output leakage current | — | 20 | — | | V _{out} = 6V |
| I _{ol} | Output leakage current | 0 | — | 10 | | V _{out} = 0V |
| V _{dgl} | Low level diagnostic output voltage | — | 0.3 | — | V | I _{dg} = 1.6mA |
| I _{dgh} | Diagnostic output leakage current | 0 | — | 10 | μA | V _{dg} = 5V |
| R _{DS(on)} | On-state resistance | — | 80 | 100 | mΩ | I _{out} = 1A |
| | | — | 120 | — | | V _{cc} = 5V, I _{out} = 1A |

Switching Electrical Characteristics

($V_{CC} = 14V$, resistive load ($R_L = 12\Omega$), $T_C = 25^\circ C$.)

| Symbol | Parameter | Min. | Typ. | Max. | Units | Test Conditions |
|---------------|----------------------------|------|------|------|-----------|-----------------|
| t_c | Over-current cycle time | — | 5 | — | ms | |
| D_c | Over-current duty cycle | — | 10 | — | % | |
| t_{on} | Turn-on delay time to 90% | — | 50 | — | μs | |
| t_{off} | Turn-off delay time to 10% | — | 60 | — | | |
| dv/dt_{on} | Slew rate on | — | 3 | — | $V/\mu s$ | |
| dv/dt_{off} | Slew rate off | — | 5 | — | | |

Protection Characteristics

| Symbol | Parameter | Min. | Typ. | Max. | Units | Test Conditions |
|-----------|---------------------------------|------|------|------|-------|------------------|
| I_{lim} | Internal current limit | — | 10 | — | A | |
| V_{sc} | Short circuit detection voltage | — | 3.5 | — | V | |
| V_{slh} | Open load detection voltage | — | 3.5 | — | | |
| V_{cl1} | Output negative clamp | 50 | 54 | — | | $I_{out} = 10mA$ |
| V_{cl2} | Output negative clamp | — | 56 | 62 | | $I_{out} = 2A$ |

Thermal Characteristics

| Symbol | Parameter | Min. | Typ. | Max. | Units | Test Conditions |
|------------|-----------------------------------------|------|------|------|--------------|-----------------|
| T_{jsd} | Thermal shutdown temperature | — | 170 | — | $^\circ C$ | |
| T_{hys} | Thermal hysteresis | — | 10 | — | | |
| R_{thjc} | Thermal resistance, junction to case | — | 3.5 | — | $^\circ C/W$ | |
| R_{thja} | Thermal resistance, junction to ambient | — | 50 | — | | |

Lead Assignments

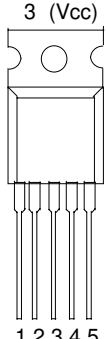
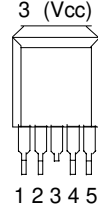
| | | |
|--------------------------------------------------------------------------------------------------------------------------------------------|-----------------------------------------------------------------|-----------------------------------------------------------------------------------------------------------------------------------------------------------------|
|  <p>3 (Vcc)</p> <p>1 2 3 4 5</p> <p>5 Lead - TO-220</p> | <p>1 - Ground 2 - In 3 - Vcc 4 - DG 5 - Out</p> |  <p>3 (Vcc)</p> <p>1 2 3 4 5</p> <p>5 Lead - D²PAK (SMD220)</p> |
| IR6220 | | IR6220S |
| Part Number | | |

Case Outline 5 Lead - TO-220

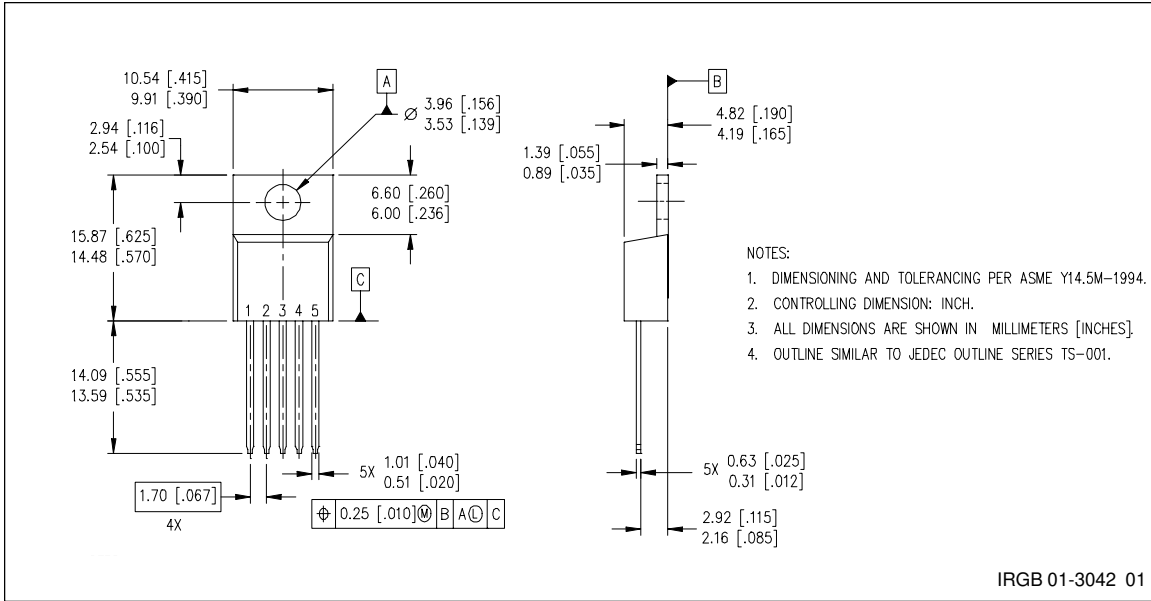

Tape & Reel 5 Lead - D²PAK (SMD220)

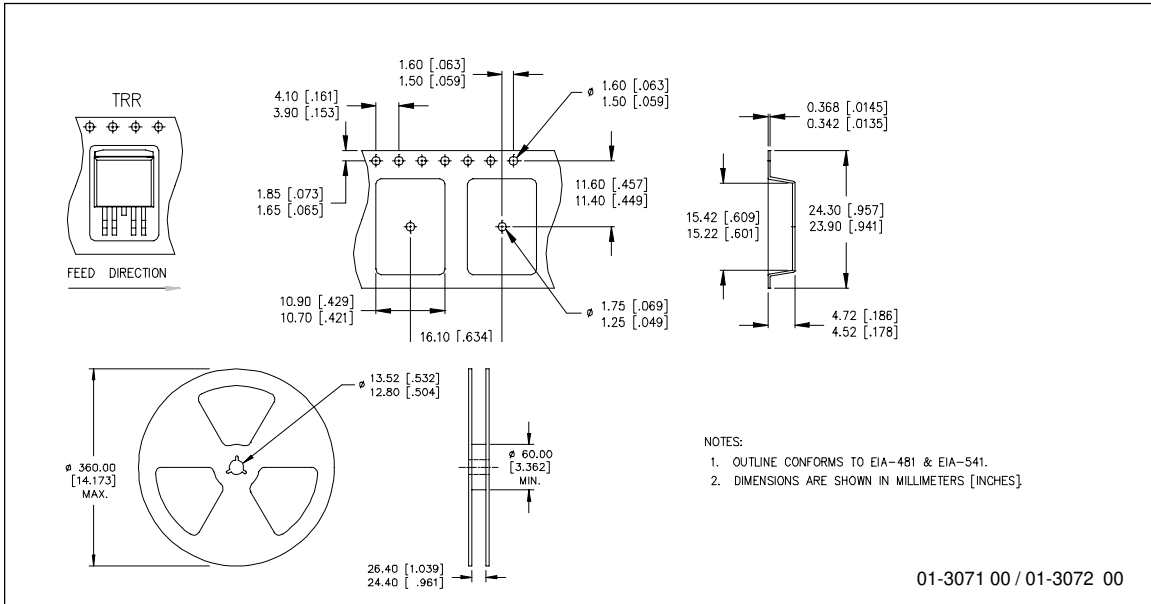

Case Outline 5 Lead - SMD220 (D²PAK)

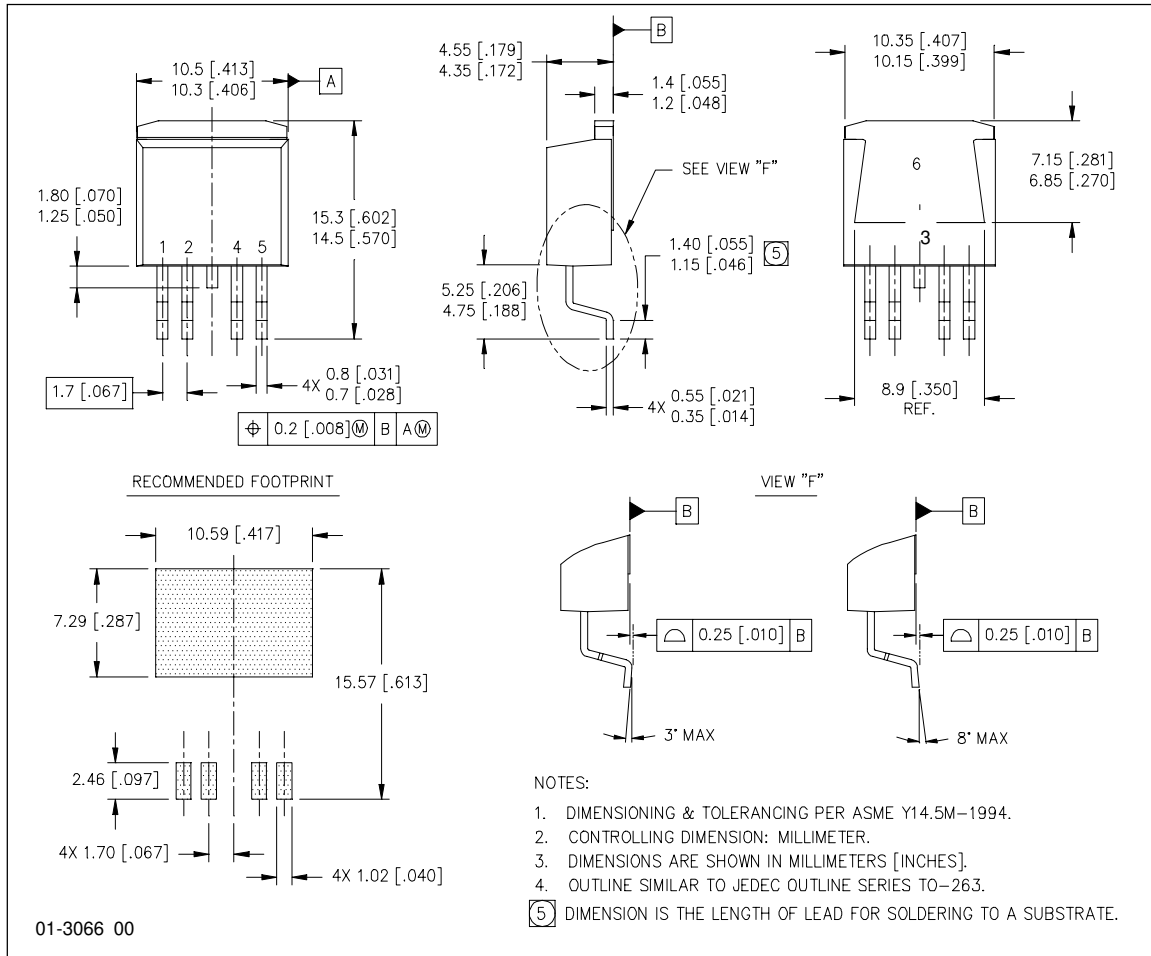

Note: For the most current drawings please refer to the IR website at:
<http://www.irf.com/package/>