



Chipsmall Limited consists of a professional team with an average of over 10 year of expertise in the distribution of electronic components. Based in Hongkong, we have already established firm and mutual-benefit business relationships with customers from,Europe,America and south Asia,supplying obsolete and hard-to-find components to meet their specific needs.

With the principle of “Quality Parts,Customers Priority,Honest Operation,and Considerate Service”,our business mainly focus on the distribution of electronic components. Line cards we deal with include Microchip,ALPS,ROHM,Xilinx,Pulse,ON,Everlight and Freescale. Main products comprise IC,Modules,Potentiometer,IC Socket,Relay,Connector.Our parts cover such applications as commercial,industrial, and automotives areas.

We are looking forward to setting up business relationship with you and hope to provide you with the best service and solution. Let us make a better world for our industry!



Contact us

Tel: +86-755-8981 8866 Fax: +86-755-8427 6832

Email & Skype: info@chipsmall.com Web: www.chipsmall.com

Address: A1208, Overseas Decoration Building, #122 Zhenhua RD., Futian, Shenzhen, China





Computing & Communications SBU - AC-DC Applications Group

222 Kansas Street, El Segundo CA90245, California, USA

IRAC1150-D2 Control Board User's Guide

Rev. 2.0

7/6/2005

Table of Contents

1	INTRODUCTION	3
1.1	Features	3
2	DESCRIPTION	3
2.1	Schematic	4
2.2	Component Layout	5
2.3	PCB Layout	5
2.4	Photos	6
2.5	Bill of Material	7
3	IRAC1150-D2 Control Board Integration into Existing Designs	8
3.1	Typical Multiplier Based System Solution	8
3.2	IRAC1150-D2 Integration into Existing Design	8
3.2.1	Output Voltage Dividers	9
3.2.2	Switching Frequency	10
3.2.3	Current Sense Resistor	10
3.2.4	Output Voltage Loop Compensation	11
3.3	Design Tips for Optimized Operation	12

Table of Figures

Figure 1	– IRAC1150-D2 Control Board Schematic Diagram	4
Figure 2	– IRAC1150-D2 Control Board Component Placement	5
Figure 3	– IRAC1150-D2 Control Board Top Layer Copper	5
Figure 4	– IRAC1150-D2 Control Board Bottom Layer Copper	6
Figure 5	– IRAC1150-D2 Photos (front and back)	6
Figure 6	- Multiplier Based System Level Schematic Diagram	8
Figure 7	- IRAC1150-D2 Control Board Integrated into Existing Design	8
Figure 8	- Switching Frequency vs Programming Resistor Value	10
Figure 9	- Voltage Loop Gain and Phase Plots	11
Figure 10	– Connection of Power Switch Source, Current Sense Resistor, and IC Ground ..	12
Table 1	- Calculated Current Sense Resistor Values for Given Output Power Levels	10

1 INTRODUCTION

The IRAC1150-D2 Control Board features the μ PFC IR1150S Power Factor Correction control IC. This document includes a description of the application in addition to schematics, PCB layout, bill of material, design process, test setup and results.

The IRAC1150-D2 Control Board is designed to demonstrate the performance of the IR1150S control IC in a continuous conduction mode boost converter for PFC. The daughter board can be inserted into existing designs to replace control cards using typical multiplier-based solutions with minor circuit modification, in addition to new dedicated designs.

There are high voltages present whenever PFC converter is energized and proper precautions should be taken to avoid potential shock and personal injury.

1.1 Features

- IEC1000-3-2 Compliant, Low Harmonic Distortion
- Universal Input Voltage
- Current Loop Controlled Power Limiting
- Brownout Protection
- Over voltage Protection – 420VDC nominal
- Open Feedback loop Protection
- 100kHz Switching Frequency, (User Programmable from 50kHz to 200kHz)
- Full Load Start Up with 40msec soft start time
- No Minimum Load Requirements and 390VDC nominal output voltage
- Sleep Mode Enable for Low Standby Current Requirement, (Blue Angel, etc.)
- V_{CC} range 14V – 20V

2 DESCRIPTION

The IR1150S is designed for use in continuous conduction mode boost converter applications for power factor correction and harmonic current reduction. The controller allows for near unity power factor and exceeds all requirements of IEC1000-3-2 for harmonic distortion.

The IC utilizes trailing edge modulation and peak current mode control to force the input current to follow the sinusoidal input voltage in both shape and phase. The IC incorporates numerous protection features for robust operation and provides a high performance solution while minimizing external components, design time, and printed circuit board area, all in an 8 pin SOIC package.

The IR1150S provides a cost effective solution for lower power designs, which are typically dominated by discontinuous mode solutions, as well as high power designs typically using 16- pin ICs requiring more external components and valuable PCB space.

2.1 Schematic

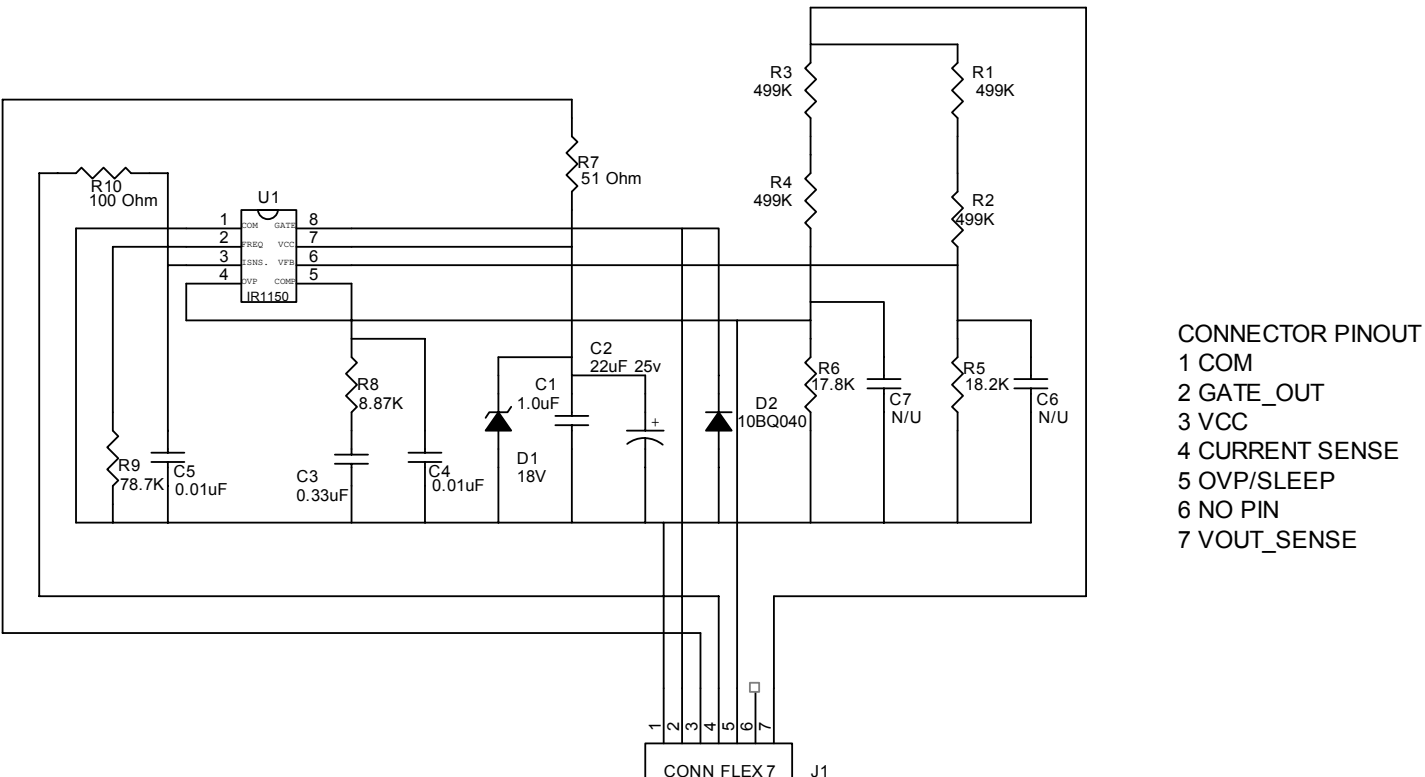

Figure 1 – IRAC1150-D2 Control Board Schematic Diagram

2.2 Component Layout

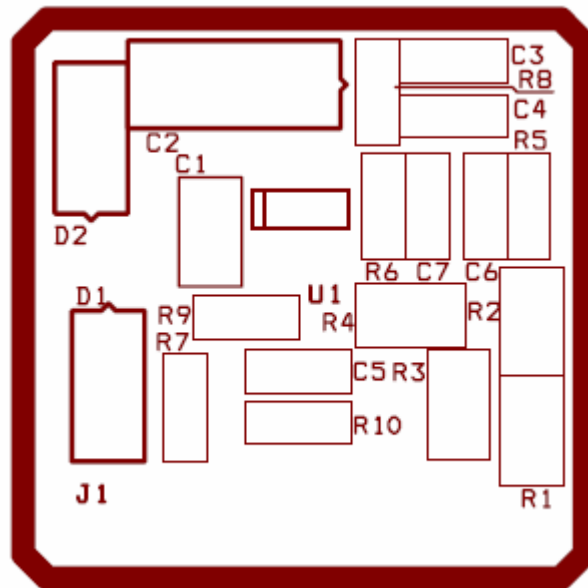

Figure 2 – IRAC1150-D2 Control Board Component Placement

2.3 PCB Layout

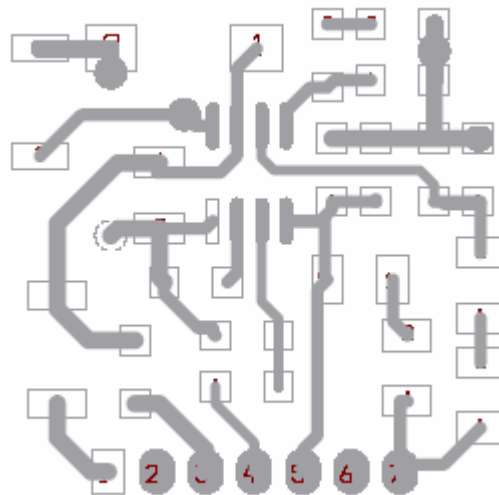

Figure 3 – IRAC1150-D2 Control Board Top Layer Copper

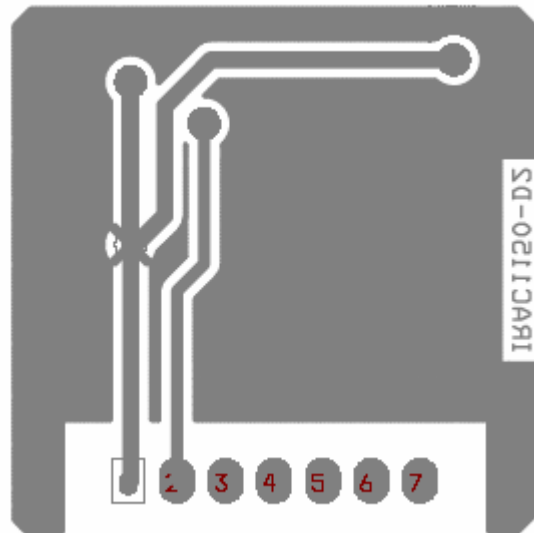

Figure 4 – IRAC1150-D2 Control Board Bottom Layer Copper

2.4 Photos

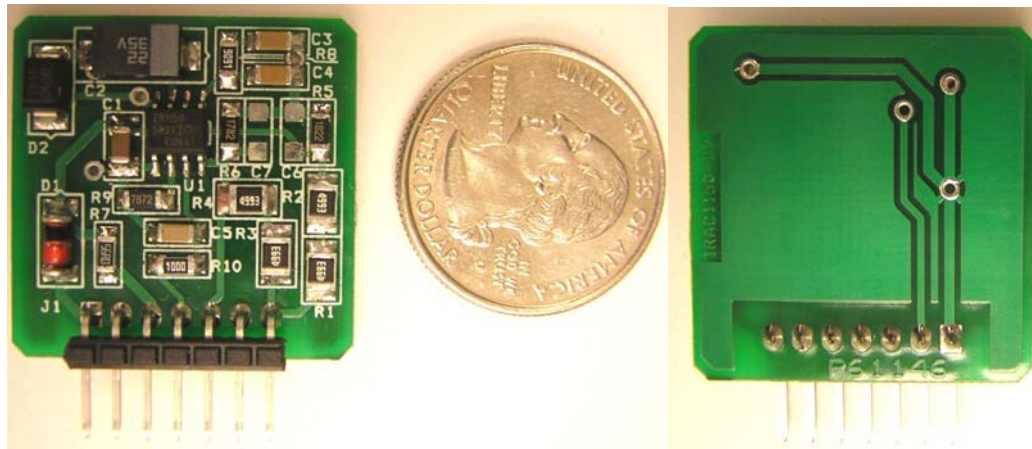

Figure 5 – IRAC1150-D2 (front and back)

2.5 Bill of Material

IRAC1150-D2 Control Board Demo - BILL OF MATERIAL						
REV: A						
	LOCATION	DESCRIPTION	SIZE:	QTY:	VENDOR	PART NUMBER
1	U1	IR1150 Control IC	SO8	1	IR	IR1150STR
	R7	51 OHM 1/4W 1%	1206 SMD	1	DIGI-KEY	311-51.0FCT-ND
2	R10	100 Ohm 1/4W 1%	1206 SMD	1	DIGI-KEY	311-100FCT-ND
3	R9	78.7K OHM 1/4W 1%	1206 SMD	1	DIGI-KEY	311-78.7KFCT-ND
4	R8	8.87K OHM 1/4W 1%	1206 SMD	1	DIGI-KEY	311-8.87KFCT-ND
5	R1 - R4	499K OHM 1/4W 1%	1210 SMD	4	DIGI-KEY	P499KAACT-ND
6	R6	17.8K OHM 1/4W 1%	1206 SMD	1	DIGI-KEY	311-17.8KFCT-ND
7	R5	18.2K OHM 1/4 1%	1206 SMD	1	DIGI-KEY	311-18.2KFCT-ND
8	C1	1.0UF 50V CERAMIC X5R	1210 SMD	1	DIGI-KEY	PCC2234CT-ND
9	C2	22UF 35V TANTALUM TEL SMD	2010 SMD	1	DIGI-KEY	P11302CT-ND
10	C3	.33UF 25V CERAMIC X7R	1206 SMD	1	DIGI-KEY	PCC1889CT-ND
11	C4,C5	.01UF 10% 50V X7R	1206 SMD	2	DIGI-KEY	478-1542-1-ND
12	C6,C7	NOT USED	N/A	N/A	N/A	N/A
13	D1	RECTIFIER Zener 18V , SMD	1206 SMD	1	DIGI-KEY	SMAZ15DICT-ND
14	D2	DIODE SCHOTTKY 40V 1A SMB	2010 SMD	1	DIGI-KEY	10BQ040-ND
15	J1	CONN HEADER 7POS.100 RA TIN	Thru Hole	1/5	DIGI-KEY	929835-01-36-ND
16	PCB	IRAC1150-D2 Control Board Rev A	1.15 x 1.15	1	Advanced	IRAC1150-D2_A

3 IRAC1150-D2 Control Board Integration into Existing Designs

3.1 Typical Multiplier Based System Solution

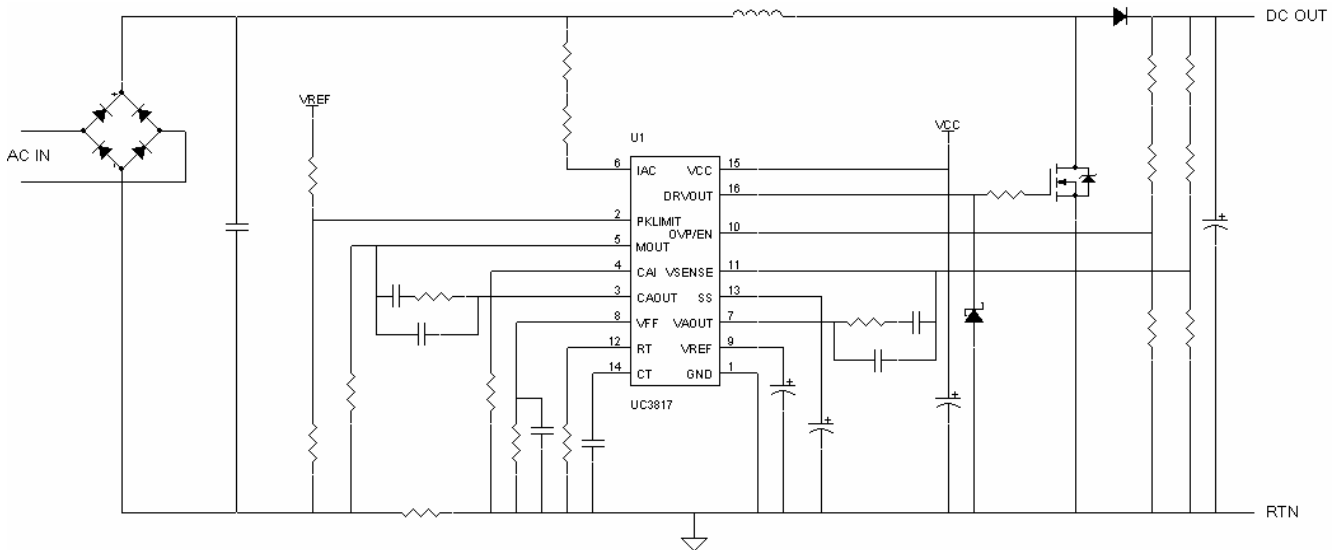

Figure 6 - Multiplier Based System Level Schematic Diagram

3.2 IRAC1150-D2 Integration into Existing Design

The IRAC1150-D2 Control Board can be integrated into SMPS designs with minor circuit level modifications. Many components can be removed from the above design when using the IRAC1150-D2. System performance will be maintained while the number of required components and pcb space will be greatly reduced. The IRAC1150-D2 Control Board is integrated into the existing design as shown below in Figure 7. The board is designed for a V_{CC} range of 14VDC to 20VDC.

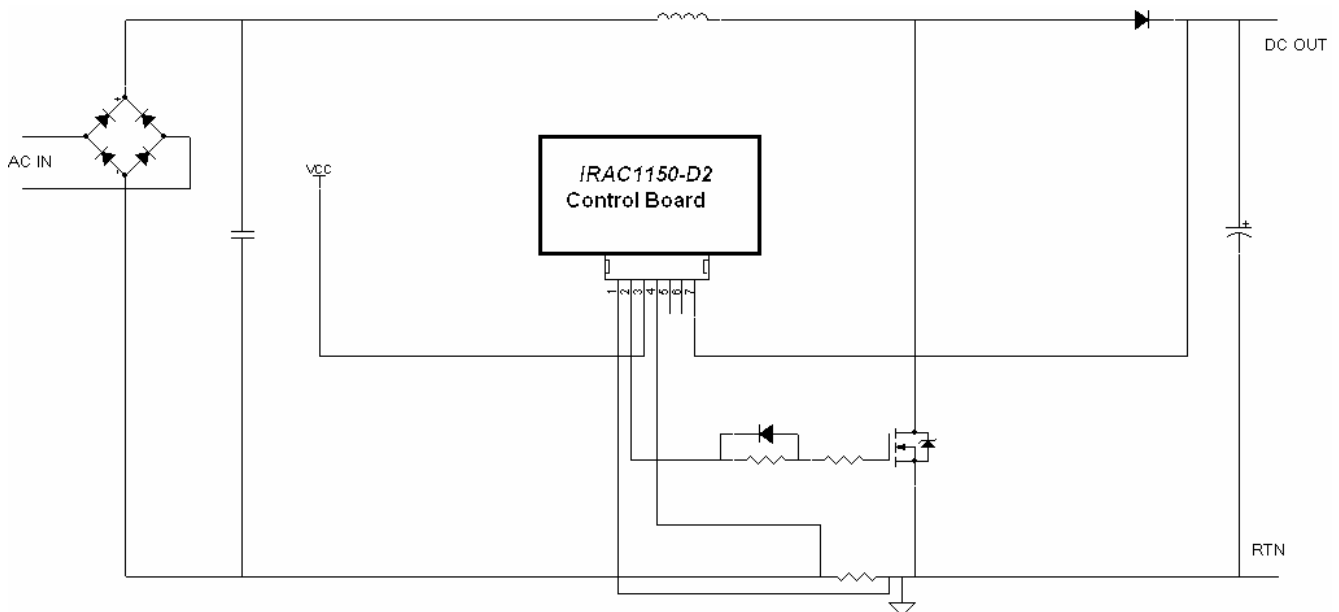

Figure 7 - IRAC1150-D2 Control Board Integrated into Existing Design

3.2.1 Output Voltage Dividers

The IRAC1150-D2 provides voltage divider strings for both the output voltage error amplifier and the overvoltage protection comparator on-board, so pin 7 is connected to the output of the converter as shown in Fig. 7. In designs where resistor divider strings are present on the motherboard, the IRAC1150-D2 can be modified according to the following, (ref schematic Fig.1). Output voltage is set for a nominal 390VDC.

Output Voltage Error Amplifier Divider

- Designs with entire divider string located on motherboard – Replace R1 and R2 with 0 ohm jumper, remove R5, and connect pin 7 to junction of divider string that normally connects to input of error amplifier of existing control board. ***Resistor values may change due to differences in reference voltages between the two controllers. Refer to IR1150S Data Sheet, (PD60230).***
- Designs with the bottom resistor of divider located on Control Board - Replace R1 and R2 with 0 ohm jumper and connect pin 7 to junction of divider string that normally connects to input of error amplifier of existing control board. Resistor R5 value may be required to change depending on resistor values on motherboard in order to maintain the same output voltage as existing design.

Over Voltage Comparator Divider

- Designs with entire divider string located on Mother Board – Remove R3, R4, and R6, connect pin 5 to junction of divider string that normally connects to input of over voltage comparator on existing control board. ***Resistor values may change due to differences in reference voltages between the two controllers. Refer to IR1150S Data Sheet, (PD60230).***
- Designs with bottom resistor of divider located on Control Board - Remove R3 and R4 then connect pin 5 to junction of divider string that normally connects to the input overvoltage comparator of existing control board. Resistor R6 value may be required to change depending on resistor values on Mother Board in order to maintain same OVP threshold as existing design.

3.2.2 Switching Frequency

The switching frequency of the IRAC1150-D2 Control Board is user programmable. The default setting is 100kHz and can be changed by removing R9 (schematic, Fig.1) and replacing it with a value from the chart in Fig. 8, corresponding to the desired switching frequency. The IR1150 controller has a frequency range of 50 – 200kHz.

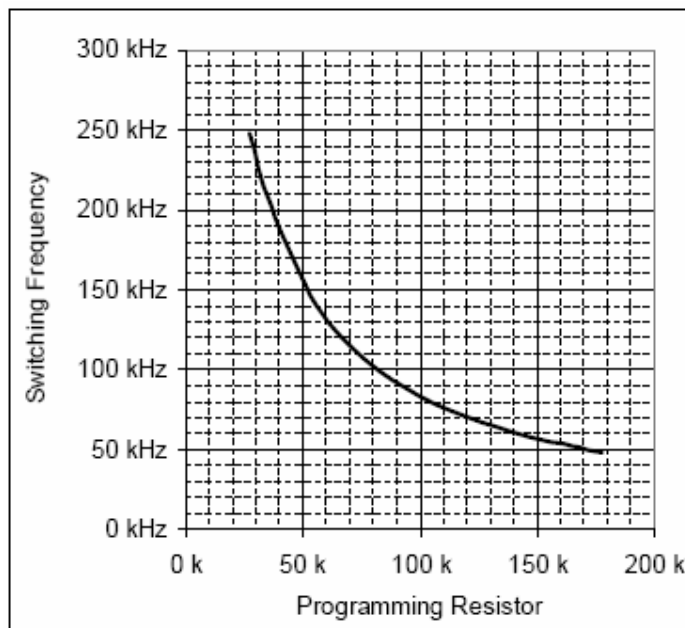

Figure 8 - Switching Frequency vs. Programming Resistor Value

3.2.3 Current Sense Resistor

Detailed design of the current sense resistor value can be found in the IR1150S Application Note AN-1077. Calculated values for a universal input converter with an 85VAC low line for typical output power levels is shown below in Table 1 (see assumptions below). Typically, the closest standard value would be selected and the calculations run again in order to optimize the system.

Output Power Level, (Watts)	Current Sense Resistor Value, (Ohms)
150	0.227
300	0.114
500	0.068
750	0.045
1000	0.034

Table 1 - Calculated Current Sense Resistor Values for Given Output Power Levels

Note: Assumes a converter overload factor of 10%, $\Delta I_L = 20\%$, converter minimum efficiency of 92% at low line of 85VAC, and converter output voltage of 385VDC.

3.2.4 Output Voltage Loop Compensation

The loop compensation provided for on the IRAC1150-D2 Control Board provides the frequency response shown below in Fig. 9. It provides for stable operation, good power factor and THD with a 28Hz crossover frequency, while providing a soft start time of approximately 40msec. The compensation should suffice for most all systems, however detailed compensation design criteria is discussed in Application Note AN-1077.

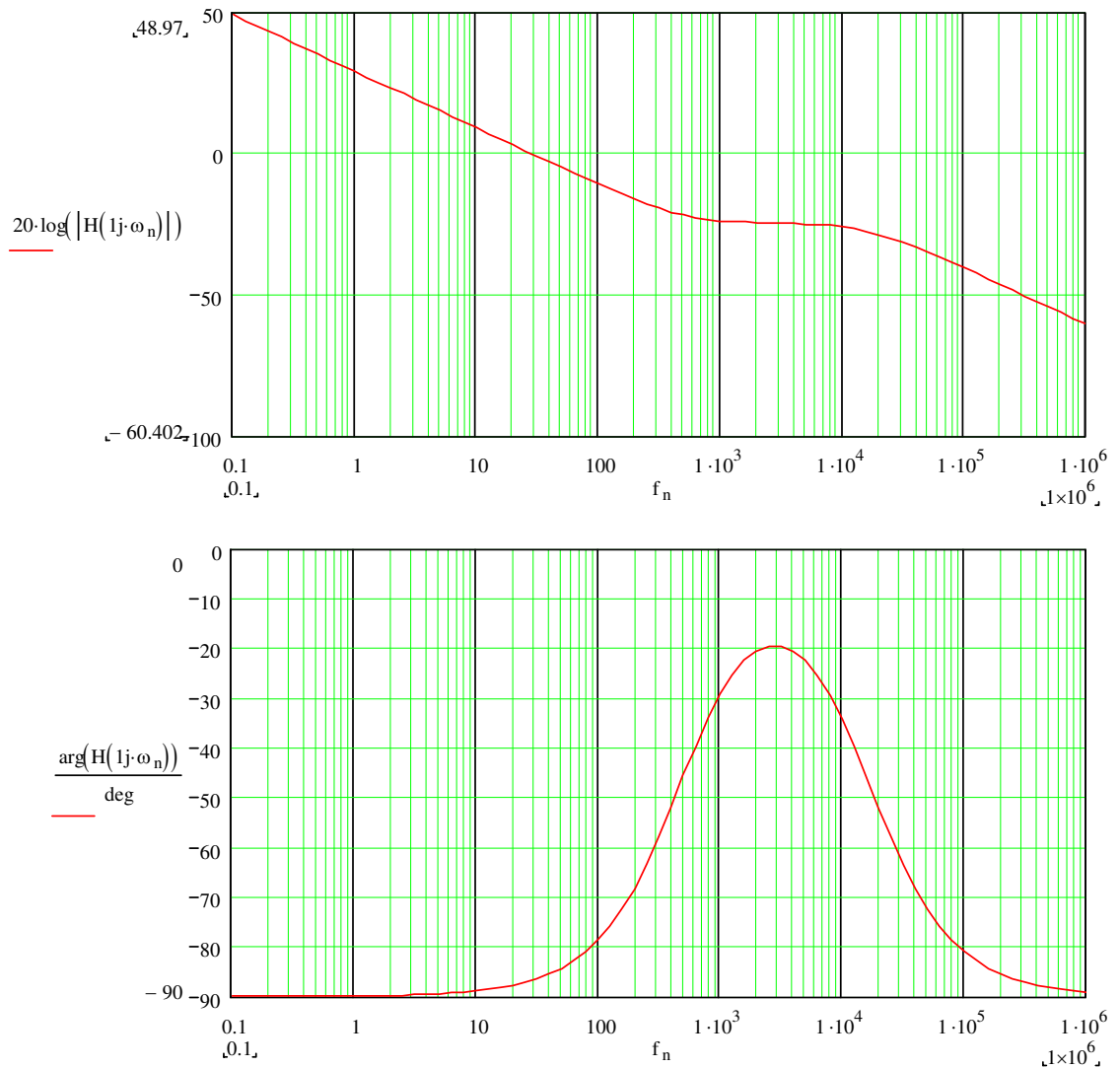

Figure 9 - Voltage Loop Gain and Phase Plots

3.3 Design Tips for Optimized Operation

- Minimize gate drive current loop - Ground pin of IC, current sense resistor, and source of power switch should be as close to a single node as practically possible. A star point connection, although not always practical in real world pcb layout, is optimum.

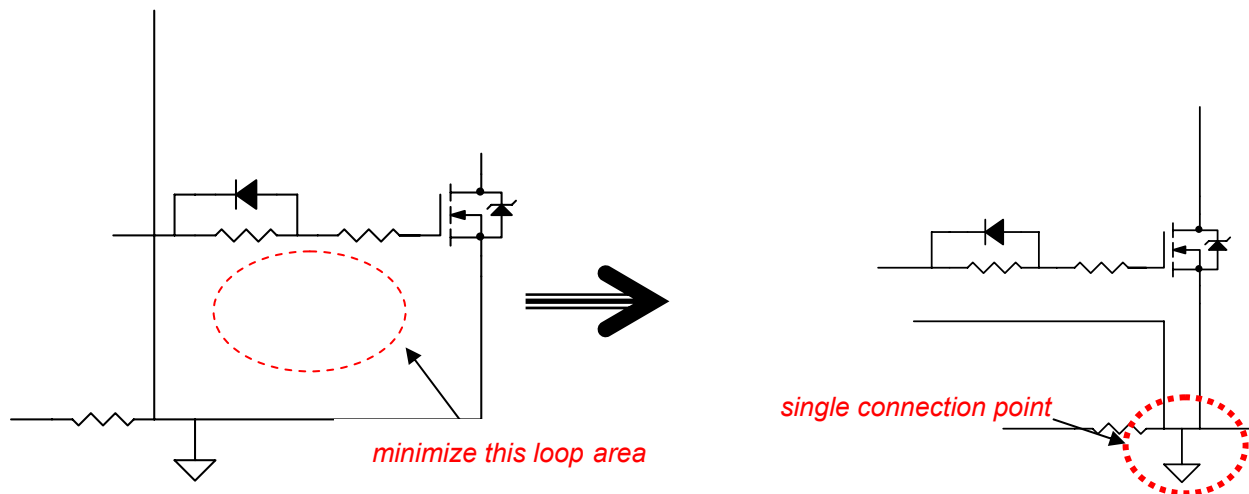

Figure 10 – Connection of Power Switch Source, Current Sense Resistor, and IC Ground

- The IRAC1150-D2 provides a robust 1.5A peak gate current. Optimization of gate drive resistors is required to achieve optimum performance in terms of system noise, EMI and efficiency. Match the drive circuit to the power switch and system requirements – e.g. the larger IRAC1150-300W Demo Board employs an IRFP27N60K power switch. The turn-on resistance is 8.9Ω and the turn off resistance is 2.7Ω . This offers a good compromise between switching losses and EMI. The gate resistors selected will depend upon the desired system level performance, the power switch selection, the boost diode selection, etc. Please refer to application notes available on the International Rectifier website which address gate drive design and optimization.
- An additional feature of the IRAC1150-D2 is the OVP/EN function, (pin 5), which is shown in the circuit of Figure 7 as not connected. This pin can be brought out into the circuit in order to initiate “sleep mode” feature of the IR1150S control IC.