



Chipsmall Limited consists of a professional team with an average of over 10 year of expertise in the distribution of electronic components. Based in Hongkong, we have already established firm and mutual-benefit business relationships with customers from,Europe,America and south Asia,supplying obsolete and hard-to-find components to meet their specific needs.

With the principle of “Quality Parts,Customers Priority,Honest Operation,and Considerate Service”,our business mainly focus on the distribution of electronic components. Line cards we deal with include Microchip,ALPS,ROHM,Xilinx,Pulse,ON,Everlight and Freescale. Main products comprise IC,Modules,Potentiometer,IC Socket,Relay,Connector.Our parts cover such applications as commercial,industrial, and automotives areas.

We are looking forward to setting up business relationship with you and hope to provide you with the best service and solution. Let us make a better world for our industry!



Contact us

Tel: +86-755-8981 8866 Fax: +86-755-8427 6832

Email & Skype: info@chipsmall.com Web: www.chipsmall.com

Address: A1208, Overseas Decoration Building, #122 Zhenhua RD., Futian, Shenzhen, China



Intelligent Power Module for
 Energy Efficient Compressor
 Applications

15A, 600V IPM
 with Integrated PFC
 and Open Emitter Pins

Description

International Rectifier's IRAM630-1562F is a 15A, 600V PFC+Inverter Intelligent Power Module (IPM) with Open Emitter pins specifically designed for energy efficient Air Conditioners application. IR's technology offers an extremely compact, high performance compressor motor-driver with both PFC and Inverter stage in a single isolated package to simplify design.

This advanced IPM is a combination of IR's low $V_{CE(on)}$ Trench IGBT technology and the industry benchmark 3 phase high voltage, high speed driver (3.3V compatible) in a fully isolated thermally enhanced package. A built-in high precision temperature monitor and over-current protection feature, along with the short-circuit rated IGBTs and integrated under-voltage lockout function, deliver high level of protection and fail-safe operation. Using a Single in line package with full transfer mold structure and CTI>600 minimizes PCB space and resolves isolation problems to heatsink.

Features

- Integrated boost PFC power stage and gate driver
- Integrated gate drivers and bootstrap circuits
- Temperature monitor
- Protection shutdown pin
- Low $V_{CE(on)}$ Trench IGBT technology
- Undervoltage lockout for all channels
- Matched propagation delay for all channels
- 3.3V Schmitt-triggered input logic
- Cross-conduction prevention logic
- Motor Power range up to 2kW / 85~253 Vac
- Isolation 2000VRMS min and CTI> 600
- RoHS Compliant
- Recognized by UL (File Number: E252584)

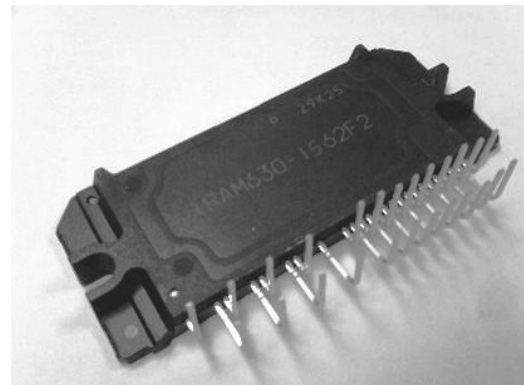

Absolute Maximum Ratings

V_{CES} / V_{RRM}	IGBT/ FW Diode Blocking Voltage	600	V
V_{AC}	AC Input Voltage	253	V_{RMS}
V^+	Positive Bus Voltage	450	V
$I_{in} @ T_C=25^\circ C$	PFC RMS Current at $F_{PWM}=20kHz$	20	A
$I_{in} @ T_C=100^\circ C$	PFC RMS Current at $F_{PWM}=20kHz$	10	
I_{pk_PFC}	PFC Maximum Peak Phase Current (Note 1)	30	
F_{p_PFC}	PFC Maximum PWM Carrier Frequency	20	kHz
P_{d_PFC}	PFC Maximum Power dissipation per IGBT @ $T_C = 25^\circ C$	62	W

Note 1: $t_p < 100ms$, $V_{CC} = 15V$, $T_C = 25^\circ C$, $F_{PWM} = 20kHz$.

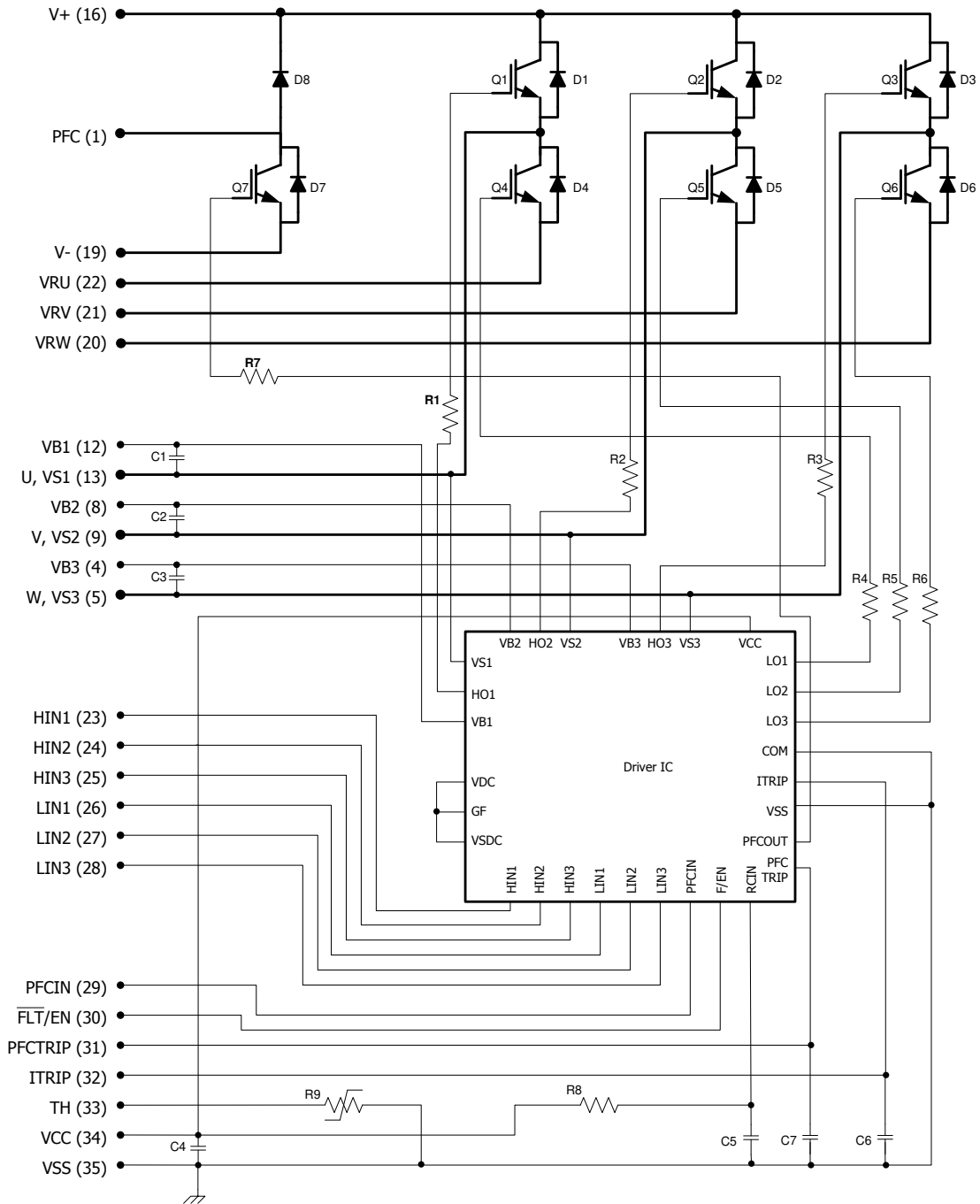
Internal Electrical Schematic – IRAM630-1562F

T_J (IGBT & Diode & IC)	Maximum Operating Junction Temperature	+150	°C
T_C	Operating Case Temperature Range	-20 to +100	
T_{STG}	Storage Temperature Range	-40 to +125	
T	Mounting torque Range (M3 screw)	0.8 to 1.0	Nm

Note 1: $t_p < 100\text{ms}$, $V_{CC} = 15\text{V}$, $T_C = 25^\circ\text{C}$, $F_{PWM} = 20\text{kHz}$.

Note 2: Sinusoidal Modulation at $V^+ = 400\text{V}$, $V_{CC} = 15\text{V}$, $T_J = 150^\circ\text{C}$, $MI = 0.8$, $PF = 0.6$, See Figure 4.

Note 3: $t_p < 100\text{ms}$, $V_{CC} = 15\text{V}$, $T_C = 25^\circ\text{C}$, $F_{PWM} = 6\text{kHz}$.

Absolute Maximum Ratings (Continued)

Symbol	Parameter	Min	Max	Units	Conditions
$V_{S1,2,3}$	High side floating supply offset voltage	$V_{B1,2,3} - 20$	$V_{B1,2,3} + 0.3$	V	
$V_{B1,2,3}$	High side floating supply voltage	-0.3	600	V	
V_{CC}	Low Side and logic fixed supply voltage	-0.3	20	V	
V_{IN}	Input voltage LIN, HIN, PFCIN, I_{TRIP} , FLT/EN	-0.3	Lower of $(V_{SS} + 15\text{V})$ or $V_{CC} + 0.3\text{V}$	V	
$V_{PFCT RIP}$	PFC _{TRIP} input voltage	-2	Lower of $(V_{SS} + 15\text{V})$ or $V_{CC} + 0.3\text{V}$	V	

PFC Section Electrical Characteristics

$V_{BIAS} (V_{CC}, V_{BS1,2,3})=15V, T_J=25^{\circ}C$, unless otherwise specified.

Symbol	Parameter	Min	Typ	Max	Units	Conditions
$V_{(BR)CES}$	Collector-to-Emitter Breakdown Voltage	600	---	---	V	$V_{IN}=0V, I_C=250\mu A$
$\Delta V_{(BR)CES} / \Delta T$	Temperature Coeff. Of Breakdown Voltage	---	0.3	---	V/ $^{\circ}C$	$V_{IN}=0V, I_C=1mA$ ($25^{\circ}C - 150^{\circ}C$)
$V_{CE(ON)}$	Collector-to-Emitter Saturation Voltage	---	1.15	1.4	V	$I_C=10A, T_J=25^{\circ}C$
		---	1.25	---		$I_C=10A, T_J=150^{\circ}C$
I_{CES}	Zero Gate Voltage Collector Current	---	10	150	μA	$V_{IN}=0V, V^+=600V$
		---	100	---		$V_{IN}=0V, V^+=600V, T_J=150^{\circ}C$
V_{FM}	Diode D8 Forward Voltage Drop	--	1.75	2.2	V	$I_F=10A$
		---	1.25	---		$I_F=10A, T_J=150^{\circ}C$
V_{FM}	Diode D7 Forward Voltage Drop	---	1.95	---	V	$I_F=3.5A$

PFC Section Switching Characteristics

$V_{BIAS} (V_{CC}, V_{BS1,2,3})=15V, T_J=25^{\circ}C$, unless otherwise specified.

Symbol	Parameter	Min	Typ	Max	Units	Conditions
E_{ON}	Turn-On Switching Loss	---	540	700	μJ	$I_C=10A, V^+=400V$ $V_{CC}=15V, L=1.2mH$ Energy losses include "tail" and diode reverse recovery
E_{OFF}	Turn-Off Switching Loss	---	220	350		
E_{TOT}	Total Switching Loss	---	760	1050		
E_{REC}	Diode Reverse Recovery energy	---	15	35		
t_{RR}	Diode Reverse Recovery time	---	140	---	ns	See CT1
E_{ON}	Turn-on Switching Loss	---	930	---	μJ	$I_C=10A, V^+=400V$ $V_{CC}=15V, L=1.2mH, T_J=150^{\circ}C$ Energy losses include "tail" and diode reverse recovery
E_{OFF}	Turn-off Switching Loss	---	310	---		
E_{TOT}	Total Switching Loss	---	1240	---		
E_{REC}	Diode Reverse Recovery energy	---	75	---		
t_{RR}	Diode Reverse Recovery time	---	180	---	ns	See CT1
Q_G	Turn-On IGBT Gate Charge	---	95	140	nC	$I_C=48A, V^+=400V, V_{GE}=15V$
RBSOA	Reverse Bias Safe Operating Area	FULL SQUARE				$T_J=150^{\circ}C, I_C=40A, V_P=600V$ $V^+=450V,$ $V_{GE}=+15V$ to 0V See CT3
SCSOA	Short Circuit Safe Operating Area	2	---	---	μs	$T_J=150^{\circ}C, V^+=360V,$ $V_{GE}=+15V$ to 0V

Inverter Section Electrical Characteristics

$V_{BIAS} (V_{CC}, V_{BS1,2,3})=15V, T_J=25^{\circ}C$, unless otherwise specified.

Symbol	Parameter	Min	Typ	Max	Units	Conditions
$V_{(BR)CES}$	Collector-to-Emitter Breakdown Voltage	600	---	---	V	$V_{IN}=0V, I_C=250\mu A$
$\Delta V_{(BR)CES} / \Delta T$	Temperature Coeff. Of Breakdown Voltage	---	0.3	---	V/ $^{\circ}C$	$V_{IN}=0V, I_C=250\mu A$ (25 $^{\circ}C$ - 150 $^{\circ}C$)
$V_{CE(ON)}$	Collector-to-Emitter Saturation Voltage	---	1.5	1.7	V	$I_C=5A, T_J=25^{\circ}C$
		---	1.7	---		$I_C=5A, T_J=150^{\circ}C$
I_{CES}	Zero Gate Voltage Collector Current	---	5	80	μA	$V_{IN}=0V, V^+=600V$
		---	80	---		$V_{IN}=0V, V^+=600V, T_J=150^{\circ}C$
V_{FM}	Diode Forward Voltage Drop	--	1.8	2.35	V	$I_F=5A$
		---	1.45	---		$I_F=5A, T_J=150^{\circ}C$
$C_{1,2,3,4}$	V_{CC} / V_{BS} Capacitor Value	---	47	---	nF	$T_J=25^{\circ}C$
$C_{6,7}$	Itrip / PFCTrip Capacitor Value	---	1	---	nF	$T_J=25^{\circ}C$

Inverter Section Switching Characteristics

$V_{BIAS} (V_{CC}, V_{BS1,2,3})=15V, T_J=25^{\circ}C$, unless otherwise specified.

Symbol	Parameter	Min	Typ	Max	Units	Conditions
E_{ON}	Turn-On Switching Loss	---	220	350	μJ	$I_C=5A, V^+=400V$ $V_{CC}=15V, L=1.2mH$ Energy losses include "tail" and diode reverse recovery
E_{OFF}	Turn-Off Switching Loss	---	85	140		
E_{TOT}	Total Switching Loss	---	305	490		
E_{REC}	Diode Reverse Recovery energy	---	15	35		
t_{RR}	Diode Reverse Recovery time	---	115	---	ns	See CT1
E_{ON}	Turn-on Switching Loss	---	320	---	μJ	$I_C=5A, V^+=400V$ $V_{CC}=15V, L=1.2mH, T_J=150^{\circ}C$ Energy losses include "tail" and diode reverse recovery
E_{OFF}	Turn-off Switching Loss	---	115	---		
E_{TOT}	Total Switching Loss	---	435	---		
E_{REC}	Diode Reverse Recovery energy	---	50	---		
t_{RR}	Diode Reverse Recovery time	---	160	---	ns	See CT1
Q_G	Turn-On IGBT Gate Charge	---	19	29	nC	$I_C=8A, V^+=400V, V_{GE}=15V$
RBSOA	Reverse Bias Safe Operating Area	FULL SQUARE				$T_J=150^{\circ}C, I_C=5A, V_P=600V$ $V^+=450V,$ $V_{CC}=+15V$ to 0V See CT3
SCSOA	Short Circuit Safe Operating Area	2	---	---	μs	$T_J=150^{\circ}C, V^+=360V,$ $V_{GE}=+17.5V$ to 0V

Recommended Operating Conditions Driver Function

The Input/Output logic timing diagram is shown in Figure 1. For proper operation the device should be used within the recommended conditions. All voltages are absolute referenced to COM. The V_S offset is tested with all supplies biased at 15V differential (Note 4)

Symbol	Definition	Min	Typ	Max	Units
$V_{B1,2,3}$	High side floating supply voltage	$V_S+12.5$	V_S+15	$V_S+17.5$	V
$V_{S1,2,3}$	High side floating supply offset voltage	Note 5	---	450	V
V_{CC}	Low side and logic fixed supply voltage	13.5	15	16.5	V
V_{IN}	Logic input voltage LIN, HIN, PFCIN, $\overline{I_{TRIP}}$, $\overline{FLT/EN}$	0	---	5	V
$V_{PFC_{TRIP}}$	PFC _{TRIP} input voltage	-2	---	0	V
HIN	High side PWM pulse width	1	---	---	μs
Deadtime	External dead time between HIN and LIN	1	---	---	μs

Note 4: For more details, see IRS26302D data sheet

Note 5: Logic operational for V_S from COM-5V to COM+600V. Logic state held for V_S from COM-5V to COM- V_{BS} . (please refer to DT97-3 for more details)

Static Electrical Characteristics Driver Function

V_{BIAS} (V_{CC} , $V_{BS1,2,3}$)=15V, $T_J=25^\circ\text{C}$, unless otherwise specified. The V_{IN} and I_{IN} parameters are referenced to COM and are applicable to all six channels. (Note 4)

Symbol	Definition	Min	Typ	Max	Units
$V_{IN,th+}$	Positive going input threshold for LIN, HIN, PFCIN, $\overline{FLT/EN}$	2.5	---	---	V
$V_{IN,th-}$	Negative going input threshold for LIN, HIN, PFCIN, $\overline{FLT/EN}$	---	---	0.8	V
V_{CCUV+} , V_{BSUV+}	V_{CC}/V_{BS} supply undervoltage, Positive going threshold	10.2	11.1	12	V
V_{CCUV-} , V_{BSUV-}	V_{CC}/V_{BS} supply undervoltage, Negative going threshold	10	10.9	11.8	V
V_{CCUVH} , V_{BSUVH}	V_{CC} and V_{BS} supply undervoltage lock-out hysteresis	---	0.2	---	V
$V(I_{TRIP})$	I_{TRIP} threshold Voltage	0.4	0.5	0.6	V
$V(I_{TRIP}, HYS)$	I_{TRIP} Input Hysteresis	---	0.05	---	V
$V(PFC_{TRIP})$	PFC _{TRIP} threshold Voltage	-0.16	-0.2	-0.24	V
$V(PFC_{TRIP}, HYS)$	PFC _{TRIP} Input Hysteresis	---	0.02	---	V
I_{QBS}	Quiescent V_{BS} supply current	---	---	120	μA
I_{QCC}	Quiescent V_{CC} supply current	---	---	4	mA
I_{LK}	Offset Supply Leakage Current	---	---	50	μA
I_{IN+}	Input bias current $V_{IN}=3.3\text{V}$ for LIN, HIN, PFCIN, $\overline{FLT/EN}$	350	--	860	μA
I_{IN-}	Input bias current $V_{IN}=0\text{V}$ for LIN, HIN, PFCIN, $\overline{FLT/EN}$	--	0	1	μA
I_{TRIP+}	I_{TRIP} bias current $V_{T/I_{TRIP}}=3.3\text{V}$	---	1	2	μA
I_{TRIP-}	I_{TRIP} bias current $V_{T/I_{TRIP}}=0\text{V}$	---	0	5	μA
PFC_{TRIP+}	PFC I_{TRIP} bias current $V_{PFC_{TRIP}}=-250\text{mV}$	---	20	---	μA
PFC_{TRIP-}	PFC I_{TRIP} bias current $V_{PFC_{TRIP}}=0\text{V}$	---	0	5	μA
R_{on_FLT}	Fault low on resistance	---	50	100	Ω
R_{BS}	Internal bootstrap FET on resistance	---	200	400	Ω

Dynamic Electrical Characteristics

V_{BIAS} (V_{CC} , $V_{BS1,2,3}$)=15V, T_J =25°C, unless otherwise specified. Driver only timing unless otherwise specified.

Symbol	Parameter	Min	Typ	Max	Units	Conditions
T_{ON}	Input to Output propagation turn-on delay time (see fig.11)	---	---	1.15	μ s	$I_C=5A$, $V^+=400V$
T_{OFF}	Input to Output propagation turn-off delay time (see fig. 11)	---	---	1.15	μ s	
T_{FILIN}	Input filter time (HIN,LIN,PFC,EN)	200	350	---	ns	$V_{IN}=0$ or $V_{IN}=3.3V$
T_{FILEN}	Input filter time (\overline{FLT} /EN)	100	200	---	ns	$V_{IN}=0$ or $V_{IN}=5V$
T_{EN}	EN low to six switch turn-off propagation delay (see fig. 3)	---	---	1.15	μ s	$V_{IN}=0$ or $V_{IN}=3.3V$, $V_{EN}=0$
T_{FLT}	I_{TRIP} to Fault propagation delay	---	800	---	ns	$V_{IN}=0$ or $V_{IN}=3.3V$, $V_{ITRIP}=3.3V$
$T_{BLT-ITRIP}$	I_{TRIP} Blanking Time	---	500	---	ns	$V_{IN}=0$ or $V_{IN}=3.3V$, $V_{ITRIP}=3.3V$
T_{ITRIP}	I_{TRIP} to six switch turn-off propagation delay (see fig. 2)	---	---	1.5	μ s	$I_C=5A$, $V^+=400V$
$T_{PFCTRIP}$	PFC_{TRIP} to switch turn-off propagation delay (see fig. 2)	---	---	1.5	μ s	$I_C=10A$, $V^+=400V$
D_T	Internal Dead Time injected by driver	190	290	420	ns	$V_{IN}=0$ or $V_{IN}=3.3V$
M_T	Matching Propagation Delay Time (On & Off) all channels	---	---	50	ns	External dead time > 400ns
$T_{FLT-CLR}$	Post I_{TRIP} to six switch turn-off clear time (see fig. 2)	1.17	1.7	2.19	ms	$T_C = 25^\circ C$
		---	1.5	---		$T_C = 100^\circ C$

Thermal and Mechanical Characteristics

Symbol	Parameter	Min	Typ	Max	Units	Conditions
$R_{th(J-C)}$	Thermal resistance, PFC IGBT	---	1.6	2.0	°C/W	Inverter Operating Condition Flat, greased surface. Heatsink compound thermal conductivity 1W/mK
$R_{th(J-C)}$	Thermal resistance, PFC Diode	---	3.0	3.6		
$R_{th(J-C)}$	Thermal resistance, per IGBT	---	3.8	4.6		
$R_{th(J-C)}$	Thermal resistance, per Diode	---	5.8	6.9		
$R_{th(C-S)}$	Thermal resistance, C-S	---	0.1	---		
CTI	Comparative Tracking Index	600	---	---	V	

Internal NTC - Thermistor Characteristics

Parameter	Definition	Min	Typ	Max	Units	Conditions
R_{25}	Resistance	44.65	47	49.35	k Ω	$T_C = 25^\circ\text{C}$
R_{125}	Resistance	1.27	1.41	1.56	k Ω	$T_C = 125^\circ\text{C}$
B	B-constant (25-50°C)	3989	4050	4111	k	$R_2 = R_1 e^{[B(1/T_2 - 1/T_1)]}$
Temperature Range		-40	---	125	°C	
Typ. Dissipation constant		---	1	---	mW/°C	$T_C = 25^\circ\text{C}$

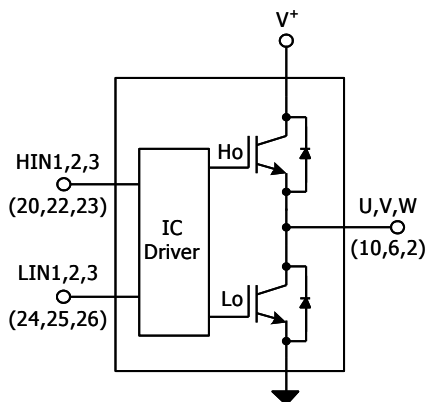
Input-Output Logic Level Table

$\overline{\text{FLT/EN}}$	I_{TRIP}	HIN1,2,3	LIN1,2,3	U,V,W
1	0	1	0	V+
1	0	0	1	0
1	0	0	0	Off
1	0	1	1	Off
1	1	X	X	Off
0	X	X	X	Off

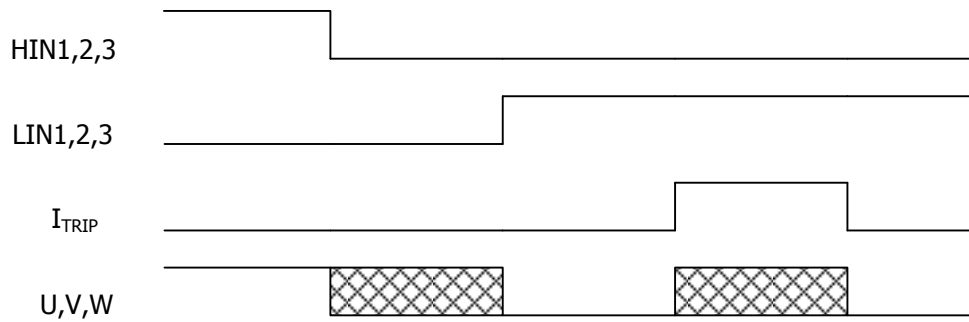

Figure 1. Input/Output Timing Diagram

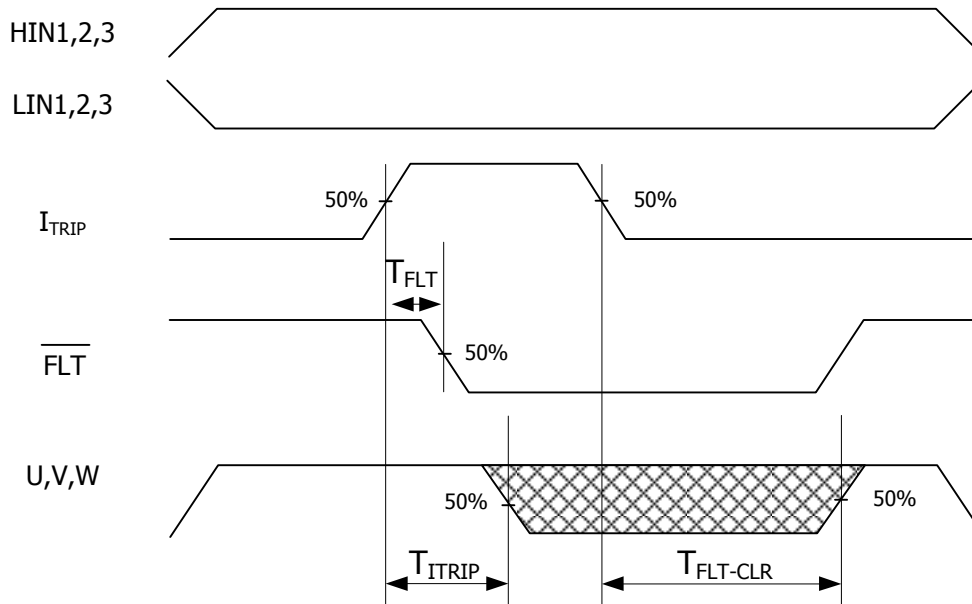

Figure 2. I_{TRIP} Timing Waveform

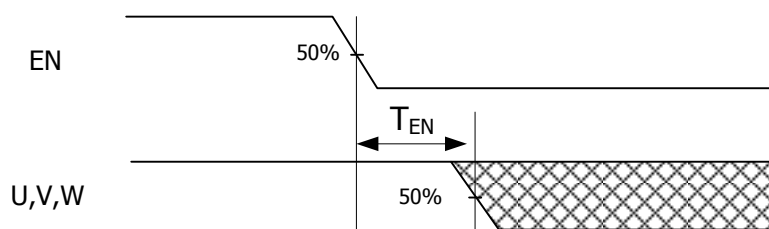
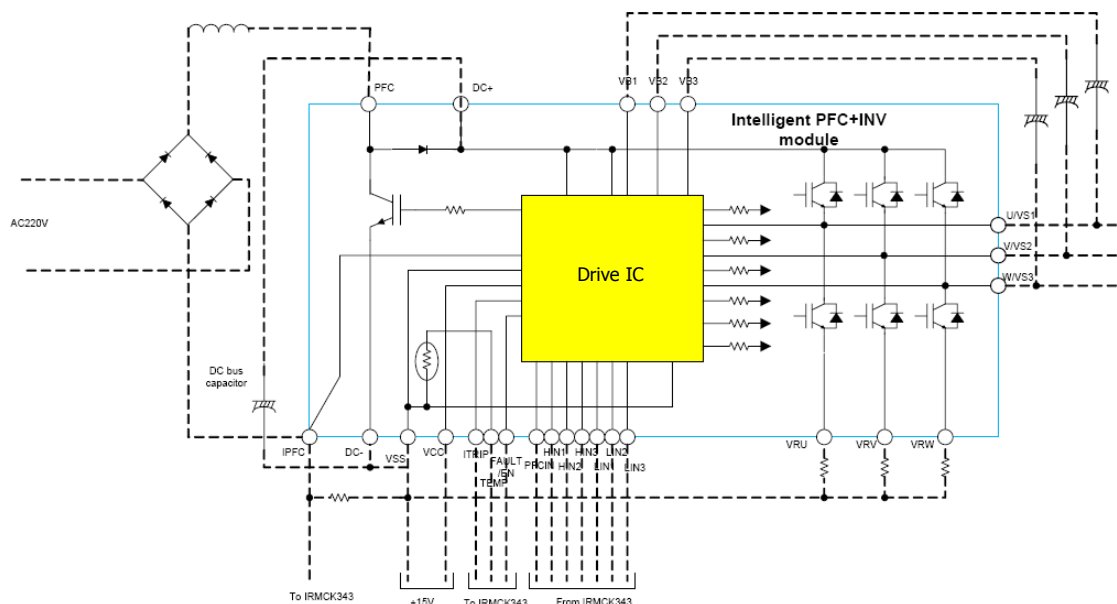

Figure 3. Output Enable Timing Diagram

Note 6: The shaded area indicates that both high-side and low-side switches are off and therefore the half-bridge output voltage would be determined by the direction of current flow in the load.

Module Pin-Out Description

Pin	Name	Description
1	PFC	PFC
2	na	none
3	na	none
4	VB3	High Side Floating Supply Voltage 3
5	W,VS3	Output 3 - High Side Floating Supply Offset Voltage
6	na	none
7	na	none
8	VB2	High Side Floating Supply voltage 2
9	V,VS2	Output 2 - High Side Floating Supply Offset Voltage
10	na	none
11	na	none
12	VB1	High Side Floating Supply voltage 1
13	U,VS1	Output 1 - High Side Floating Supply Offset Voltage
14	na	none
15	na	none
16	V ⁺	Positive Bus Input Voltage
17	na	none
18	na	none
19	V ⁻	Negative Bus Input Voltage
20	VRW	Low Side Emitter Connection - Phase 3
21	VRV	Low Side Emitter Connection - Phase 2
22	VRU	Low Side Emitter Connection - Phase 1
23	HIN1	Logic Input High Side Gate Driver - Phase 1
24	HIN2	Logic Input High Side Gate Driver - Phase 2
25	HIN3	Logic Input High Side Gate Driver - Phase 3
26	LIN1	Logic Input Low Side Gate Driver - Phase 1
27	LIN2	Logic Input Low Side Gate Driver - Phase 2
28	LIN3	Logic Input Low Side Gate Driver - Phase 3
29	PFCIN	PFC input
30	$\overline{\text{FLT/EN}}$	Fault Output and Enable Pin
31	PFC _{TRIP}	Current Protection Pin for PFC
32	I _{TRIP}	Current Protection Pin for Inverter
33	V _{TH}	Temperature Feedback
34	V _{CC}	+15V Main Supply
35	V _{SS}	Negative Main Supply

Typical Application Connection IRAM630-1562F

1. Electrolytic bus capacitors should be mounted as close to the module bus terminals as possible to reduce ringing and EMI problems. Additional high frequency ceramic capacitor mounted close to the module pins will further improve performance.
2. In order to provide good decoupling between VCC-VSS and VB1,2,3-VS1,2,3 terminals, the capacitors shown connected between these terminals should be located very close to the module pins. Additional high frequency capacitors, typically 0.1 μ F, are strongly recommended.
3. Value of the boot-strap capacitors depends upon the switching frequency. Their selection should be made based on IR design tip DT04-4, application note AN-1044 or Figure 11. Bootstrap capacitor value must be selected to limit the power dissipation of the internal resistor in series with the VCC. (see maximum ratings Table on page 3).
4. After approx. 2ms the FAULT is reset. (see Dynamic Characteristics Table on page 5).
5. PWM generator must be disabled within Fault duration to guarantee shutdown of the system, overcurrent condition must be cleared before resuming operation.

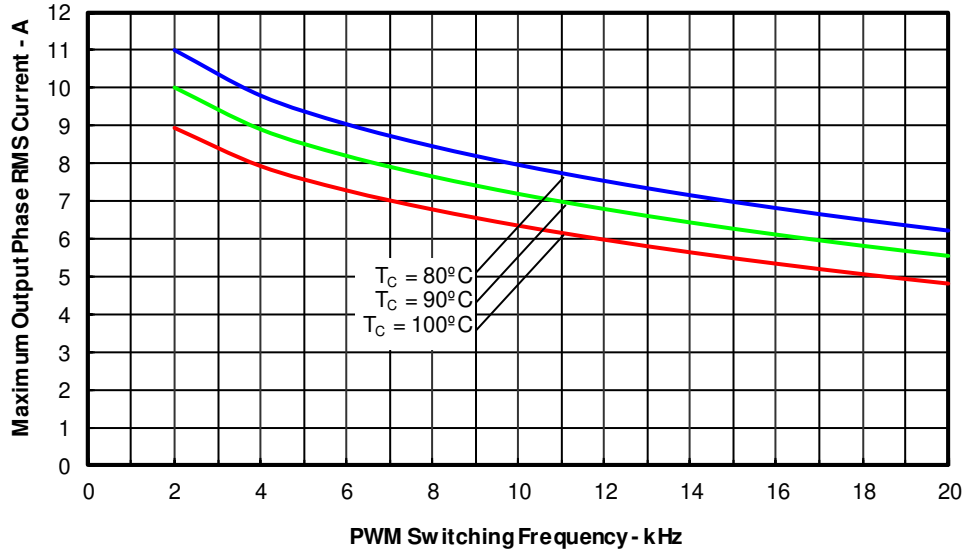

Figure 4. Maximum Sinusoidal Phase Current vs. PWM Switching Frequency
Sinusoidal Modulation, $V^+=400V$, $T_J=150^\circ C$, $MI=0.8$, $PF=0.6$, $f_{mod}=50Hz$

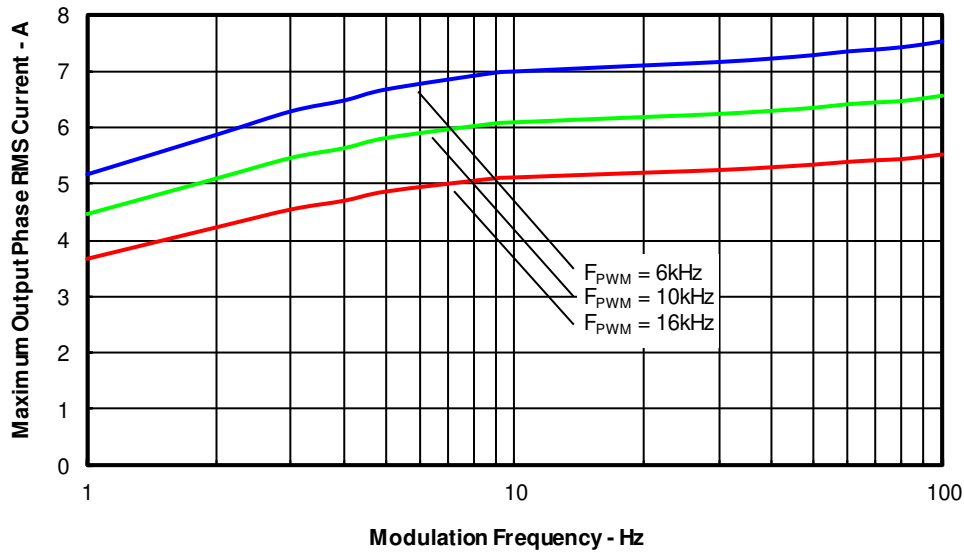

Figure 5. Maximum Sinusoidal Phase Current vs. Modulation Frequency
Sinusoidal Modulation, $V^+=400V$, $T_J=150^\circ C$, $T_C=100^\circ C$, $MI=0.8$, $PF=0.6$

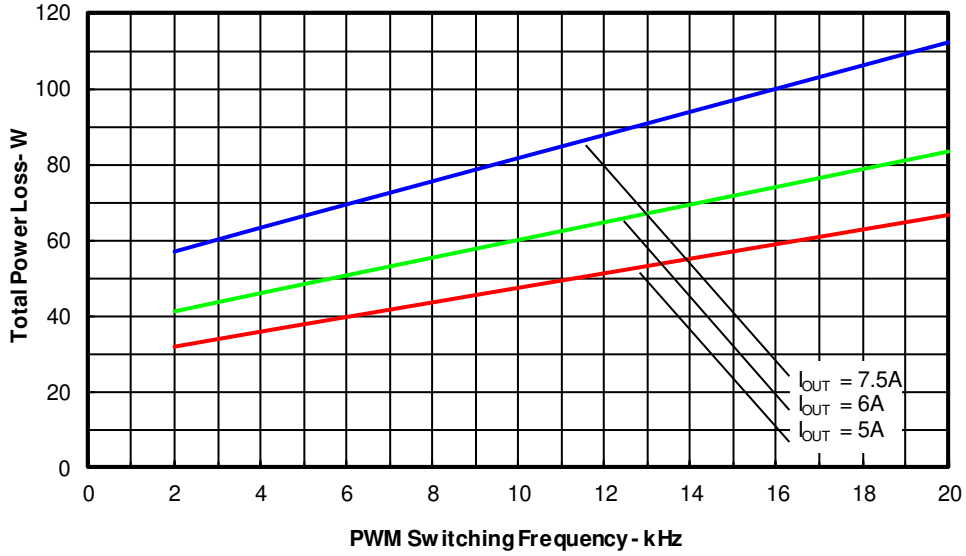

Figure 6. Total Power Losses vs. PWM Switching Frequency
 Sinusoidal Modulation, $V^+=400V$, $T_J=150^\circ C$, $MI=0.8$, $PF=0.6$, $f_{mod}=50Hz$

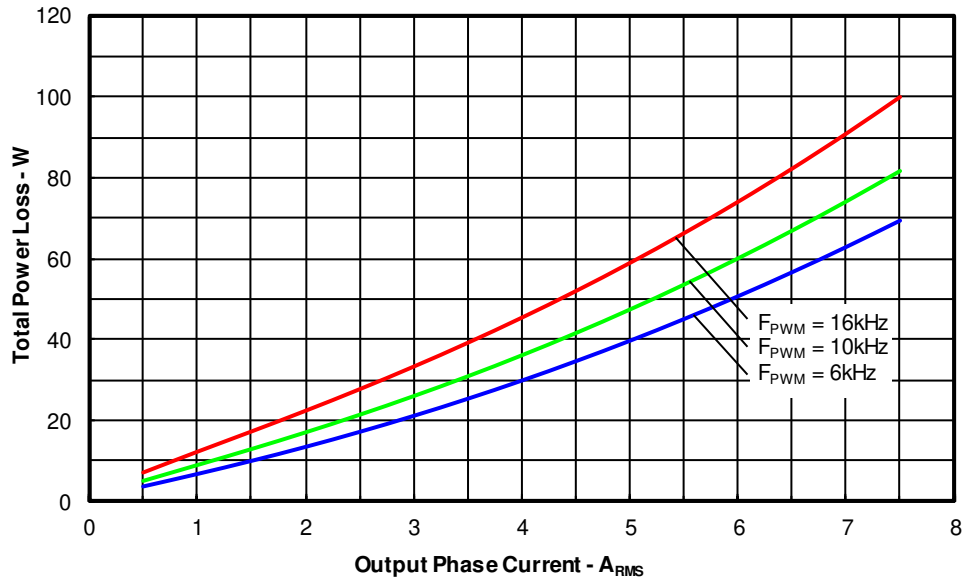

Figure 7. Total Power Losses vs. Output Phase Current
 Sinusoidal Modulation, $V^+=400V$, $T_J=150^\circ C$, $MI=0.8$, $PF=0.6$, $f_{mod}=50Hz$

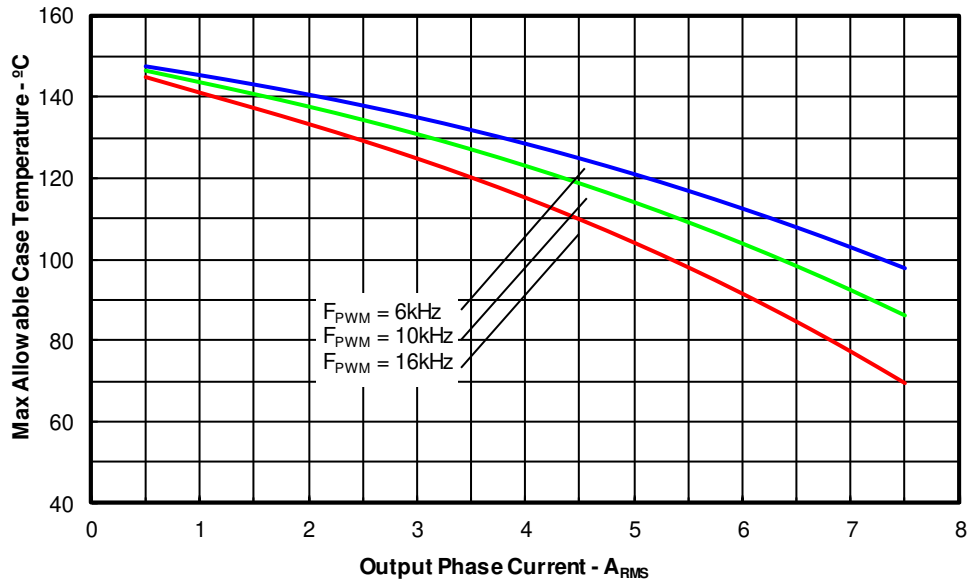

Figure 8. Maximum Allowable Case Temperature vs. Output RMS Current per Phase Sinusoidal Modulation, $V^+=400V$, $T_J=150^\circ C$, $MI=0.8$, $PF=0.6$, $f_{mod}=50Hz$

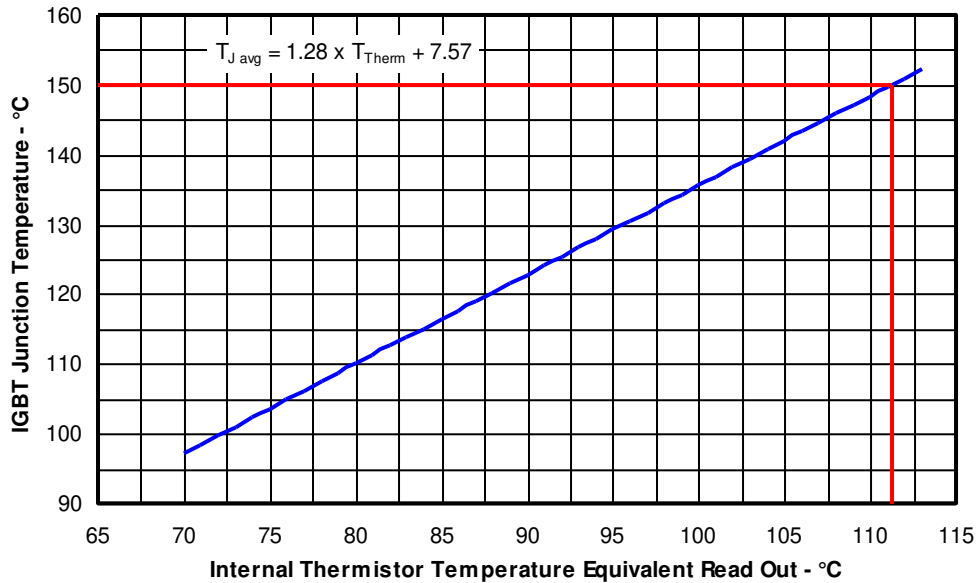

Figure 9. Estimated Maximum IGBT Junction Temperature vs. Thermistor Temperature Sinusoidal Modulation, $V^+=400V$, $I_{phase}=5A_{RMS}$, $f_{sw}=16kHz$, $f_{mod}=50Hz$, $MI=0.8$, $PF=0.6$

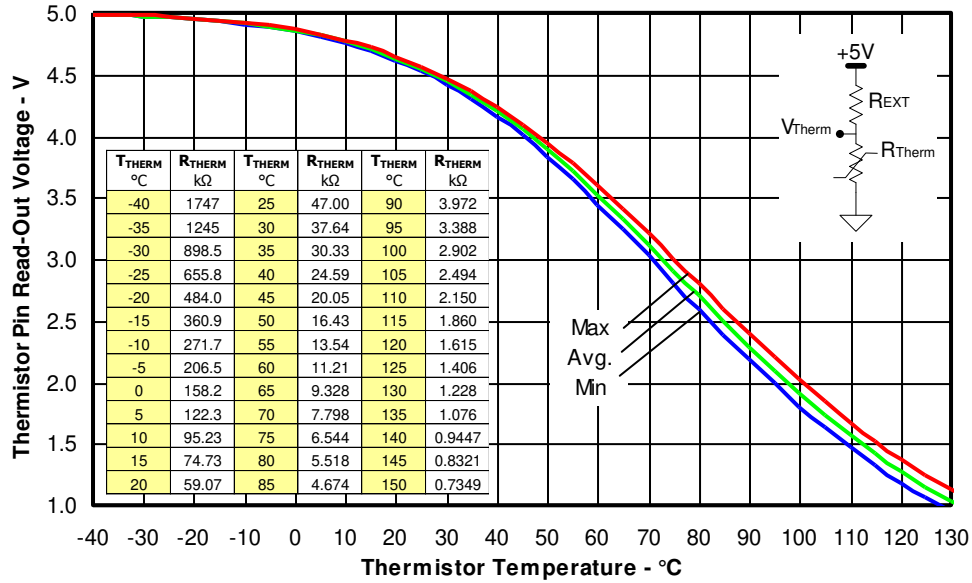

Figure 10. Thermistor Readout vs. Temperature (4.7kohm pull-up resistor, 5V) and Normal Thermistor Resistance values vs. Temperature Table.

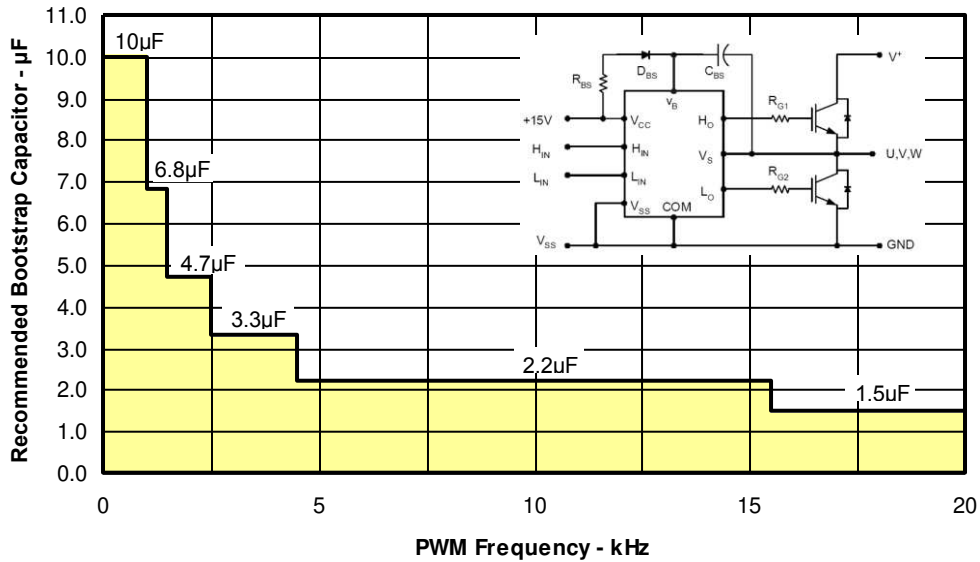

Figure 11. Recommended Bootstrap Capacitor Value vs. Switching Frequency

Figure 12. Switching Parameter Definitions

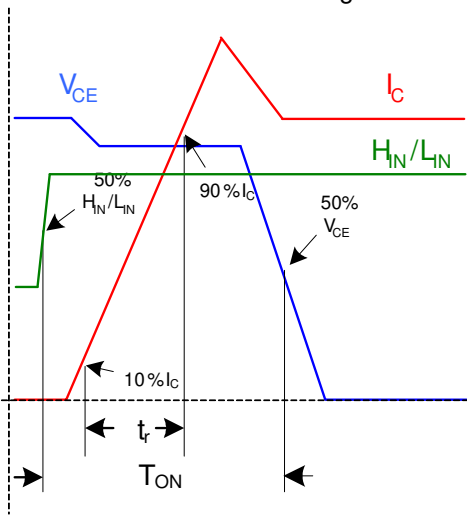

Figure 12a. Input to Output propagation turn-on delay time.

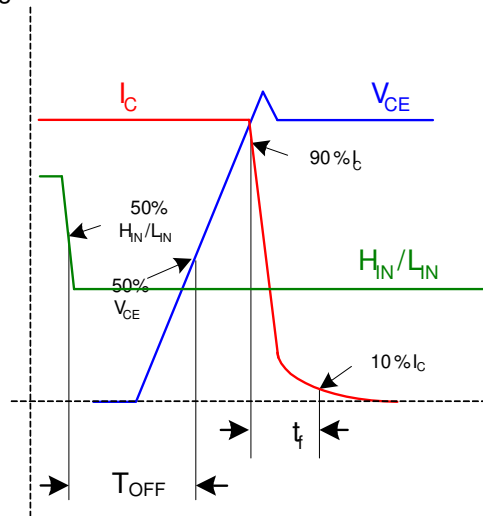

Figure 12b. Input to Output propagation turn-off delay time.

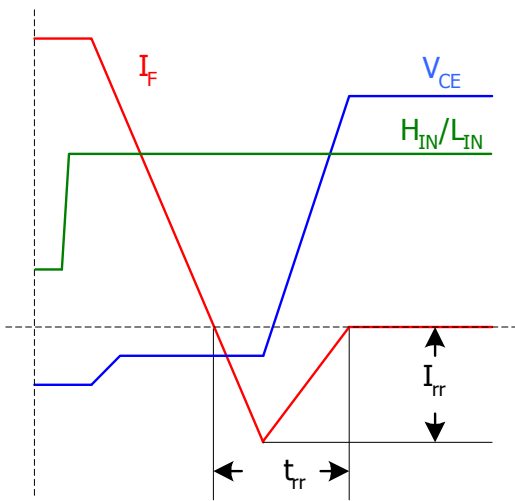

Figure 12c. Diode Reverse Recovery.

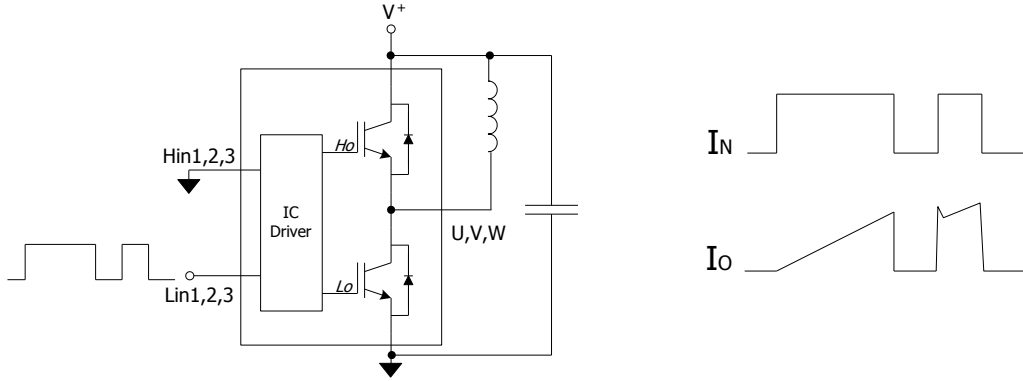

Figure CT1. Switching Loss Circuit

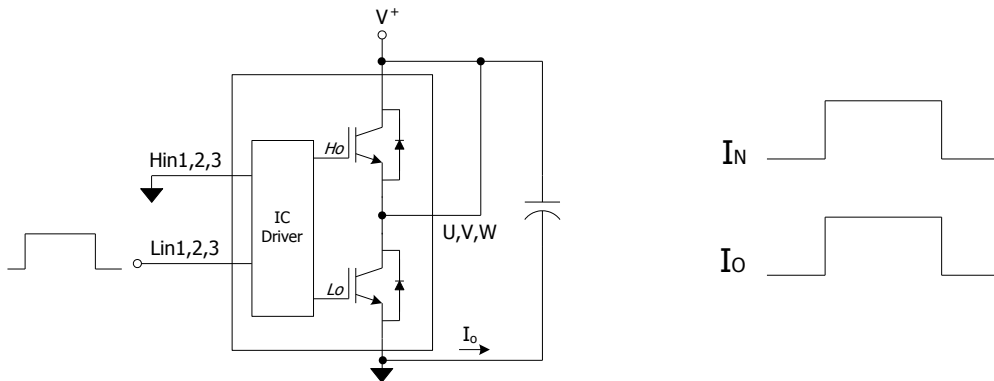

Figure CT2. S.C.SOA Circuit

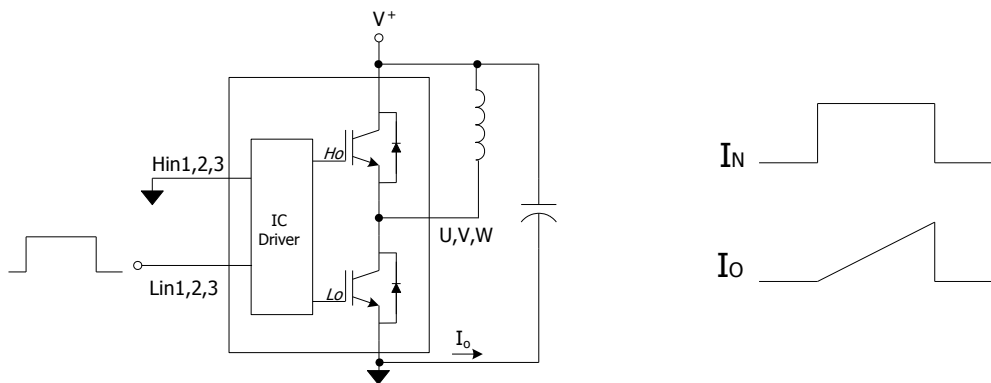
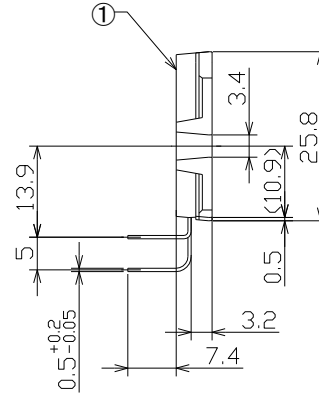
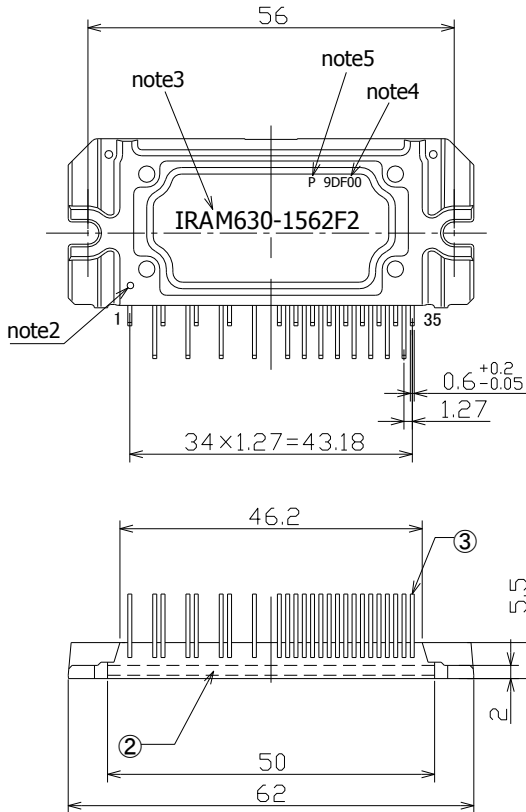

Figure CT3. R.B.SOA Circuit

Package Outline IRAM630-1562F2

missing pin : 2,3,6,7,10,11,14,15,17,18



- note1: Unit Tolerance is +0.5mm, Unless Otherwise Specified.
- note2: Mirror Surface Mark indicates Pin1 Identification.
- note3: Part Number Marking. Characters Font in this drawing differs from Font shown on Module.
- note4: Lot Code Marking. Characters Font in this drawing differs from Font shown on Module.
- note5: "P" Character denotes Lead Free. Characters Font in this drawing differs from Font shown on Module.

Dimensions in mm
For mounting instruction see AN-1049

