



Chipsmall Limited consists of a professional team with an average of over 10 year of expertise in the distribution of electronic components. Based in Hongkong, we have already established firm and mutual-benefit business relationships with customers from,Europe,America and south Asia,supplying obsolete and hard-to-find components to meet their specific needs.

With the principle of “Quality Parts,Customers Priority,Honest Operation,and Considerate Service”,our business mainly focus on the distribution of electronic components. Line cards we deal with include Microchip,ALPS,ROHM,Xilinx,Pulse,ON,Everlight and Freescale. Main products comprise IC,Modules,Potentiometer,IC Socket,Relay,Connector.Our parts cover such applications as commercial,industrial, and automotives areas.

We are looking forward to setting up business relationship with you and hope to provide you with the best service and solution. Let us make a better world for our industry!



Contact us

Tel: +86-755-8981 8866 Fax: +86-755-8427 6832

Email & Skype: info@chipsmall.com Web: www.chipsmall.com

Address: A1208, Overseas Decoration Building, #122 Zhenhua RD., Futian, Shenzhen, China



IRAUDPS1

**12V System Scalable 250W to 1000W Audio Power Supply
For Class D Audio Power Amplifiers
Using the IR2085 self oscillating gate driver
And Direct FETS IRF6648**

By

Manuel Rodríguez



CAUTION:

International Rectifier suggests the following guidelines for safe operation and handling of IRAUDPS1 Demo Board:

- **Always wear safety glasses whenever operating Demo Board**
- **Avoid personal contact with exposed metal surfaces when operating Demo Board**
- **Turn off Demo Board when placing or removing measurement probes**

Item	Table of Contents	Page
1	Introduction	3
2	System Specifications	4
3	Functional Block Description	5
4	IRAUDPS1 Block Diagram	6
5	Schematic IR2085 module	7
6	IRAUDPS1 mother board schematic	8
7	IR2085 module PCB layout	9
8	IRAUDPS1 mother PCB layout	10-11
9	BOM of IR2085 module	12
10	BOM of IRAUDPS1 mother board	13-14
11	BOM of Mechanical parts	14
12	Scalable IRAUDPS1 power table	14
13	Performance and test procedure	15-21
14	IRAUDPS1 Fabrication Drawings	22-24
15	Transformer winding instructions	25-27
16	Design example	28
17	Transformer design	28-30
18	MOSFET selection	30
19	Switching losses	31
20	Efficiency calculations	32
21	Frequency of oscillation	33
22	Selecting dead time	33
23	Over Temperature Protection	33
24	Short circuit protection	33
25	BJT gate driver option	33
26	Music Load	34
25	Revision Changes Descriptions	35

Introduction

The IRAUDPS1 reference design is a 12 volts systems Audio Power Supply for automotive applications designed to provide voltage rails (+B and –B) for Class D audio power amplifiers

This reference design demonstrates how to use the IR2085 as PWM and gate driver for a Push-Pull DC to DC converter, along with IR’s Direct FETS IRF6648

The resulting design uses a compact design with the Direct FETS and provides all the required protections.

NOTE: The IRAUDPS1 is an scalable power output design, and unless otherwise noted, this user’s manual and the reference design board is the 500W

Table 1 IRAUDPS1 scalable table

IRAUDPS1				
		250W	500W	1000W
Nominal Voltage output	+B, -B	±35V	±35V	±35V
Nominal Output Current	+B, -B	3.5A	7A	14A
Application		Stereo System 100W x 2	8 channel System 100W x 4	8 channel System 100W x 8
IR Class D Model		IRAUDAMP7D	IRAUDAMP8	IRAUDAMP8 x 2
Detailed output power versions that can be configured by replacing components given in the component selection of Table 7 on page 14				

System Specification

All specs and tests are based on a 14.4V battery voltage supplying an International Rectifier Class D reference design with all channels driven at 1 kHz and a resistive load.

Table 2

Specification	250W	IRAUDPS1	1000W
IR Class D Load	IRAUDAMP5	IRAUAMP8	IRAUAMP8 x 2
Input current with no load	0.35A +/- 10%	0.35A +/- 10%	0.35A +/- 10%
ACC Remote ON Level	4.5-6V	4.5-6V	4.5-6V
ACC input impedance	10k+/- 10%	10k+/- 10%	10k+/- 10%
Turn ON delay	1-1.5 Sec	1-1.5 Sec	1-1.5 Sec
In-Rush Current	30A Max	30A Max	30A Max
Output power full loaded	250W	500W	1000W
Input current full loaded	18A	35.5A	71A
Output Current per supply	3.5A	7A	14A
Output voltage	+/- 35V +/-10%	+/- 35V +/-10%	+/- 35V +/-10%
Regulation	+/- 10%	+/- 10%	+/- 15%
Ripple outputs, laded at 400W audio 1khz	1.5V P.P.	1.8V P.P.	2V P.P.
Efficiency at 1/2 and full of rated power	90-85%	92-87%	90-80%
Isolation between Battery and Outputs Gnd	1k Ohm	1k Ohm	1k Ohm
Battery OVP	18-18.5V	18-18.5V	18-18.5V
Battery UVP	8.0-8.5V	8.0-8.5V	8.0-8.5V
Output SCP	10A	20A	40A
Outputs OVP	40-45V	40-45V	40-45V
Over temperature protection (OTP)	90C +/- 5C	90C +/- 5C	90C +/- 5C
OTP hysteresis	10C	10C	10C
Led Indicators	Red LED= SCP, Blue LED= OK		
Size	3" W x 5.3" L x 1.5" H		

Table 3

+B, -B Voltage outputs vs. Battery voltage all models

Voltage outputs at 16.0V battery input with no signal input at class D	+/- 39.5V +/- 10%
Voltage outputs at 12.0V	+/- 28V +/- 10%
Voltage outputs at 8.0V battery input with no signal input at class D	+/- 19.2V +/- 10%

Functional Block Description

Fig 1 below shows the functional block diagram which basically is an isolated DC-DC converter with a step-up push-pull transformer from a 12V system that converts it to +/- 35V using the IR2085 as a PWM and gate driver along with the Direct FETS IRF6648.

The IR2085 Module contains all the housekeeping circuitry to protect the IRAUDPS1 against streamer conditions which are:

1. Soft start circuit in order to control the inrush-current at the moment the IRAUDPS1 power is turned ON
2. Short Circuit protection at outputs (SCP), which will shut down the IR2085 and remain in latch mode until the Remote ON /OFF switch is released
3. 12V system Over Voltage protection (OVP1). if Battery input voltage is greater than 18V.. this could happen when the vehicle's battery is disconnected or a vehicle's alternator fails.
4. Over voltage Output (OVP2) is greater than +/-45V at +B terminal if battery input is greater than 16V
5. Over Temperature Protection (OTP), resistor Thermistor senses the chassis temperatures from Direct FETS

Fig 2 is the complete schematic for the IR2085 Module

Fig 3 is the complete schematic for the IRAUDPS1 with all scalable components required

Figs 4 to Fig 10 are the respective PCB layouts for the IR2085 Module and the IRAUDPS1 motherboard

Tables 4 to Table 6 are the respective bills of materials

Table 7 is the IRAUDPS1 detailed output power versions that can be configured by replacing components

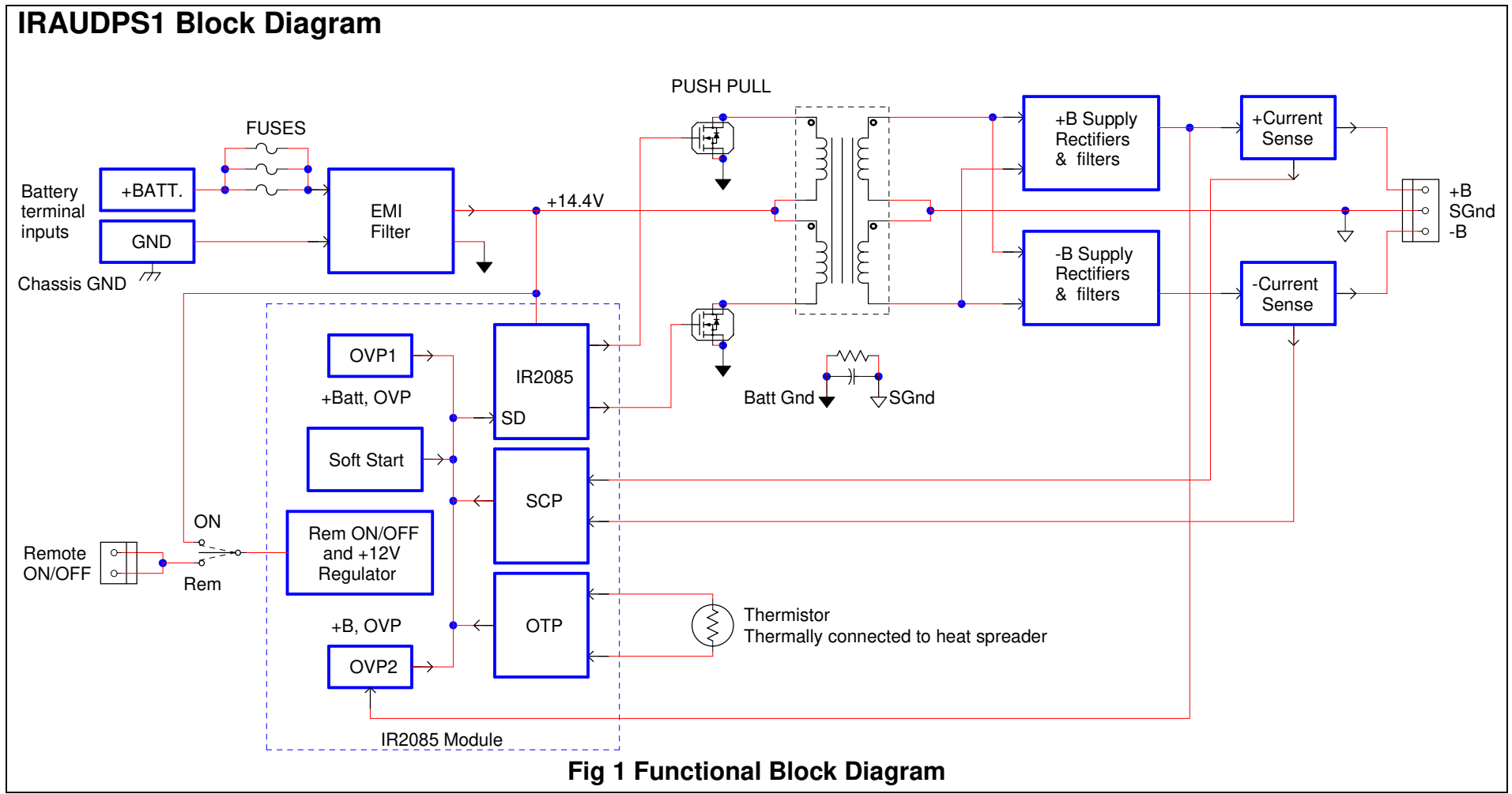

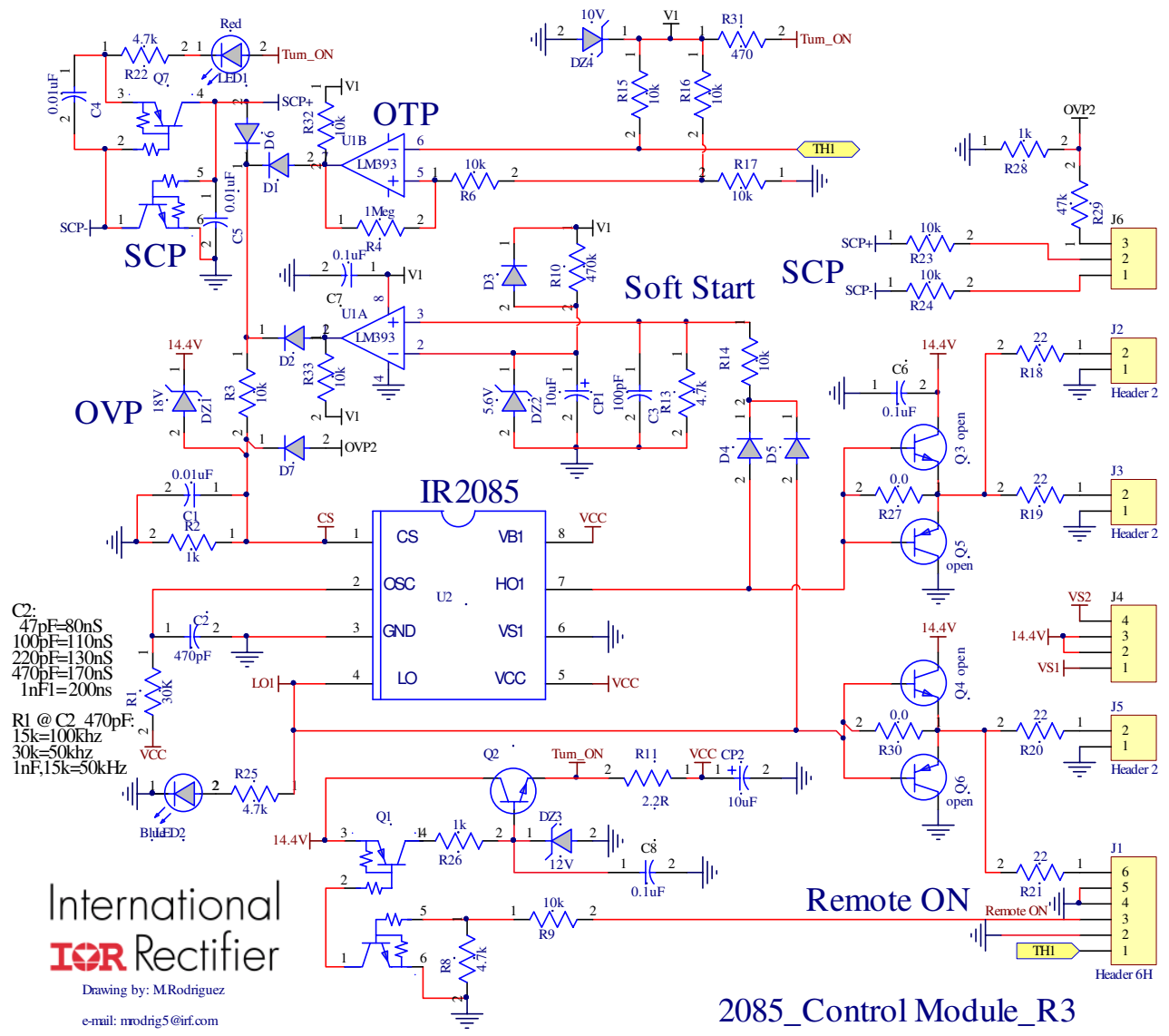

Fig 2 schematic of IR2085 Module

IRAUDPS1, 12V System SMPS, 500W Converter with Direct Fets
And IR2085 PWM Module

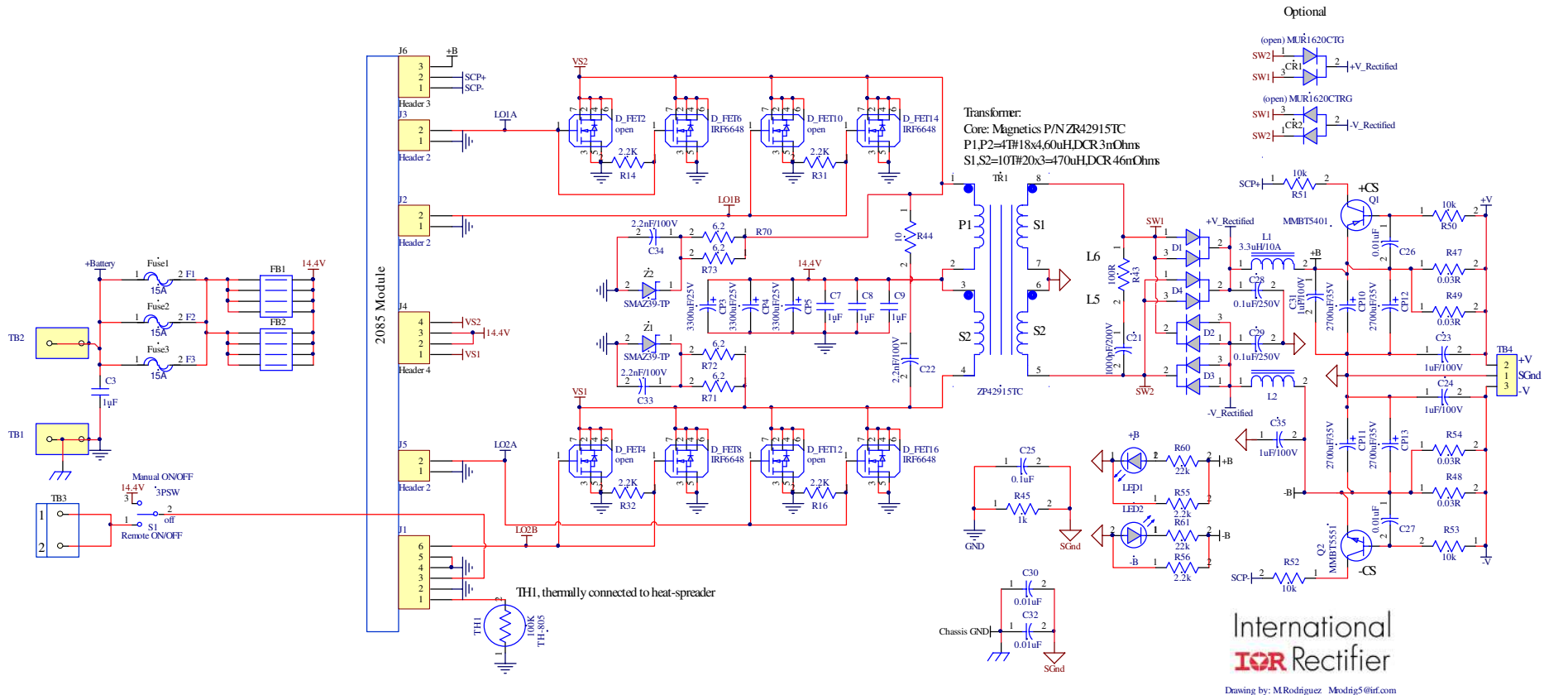
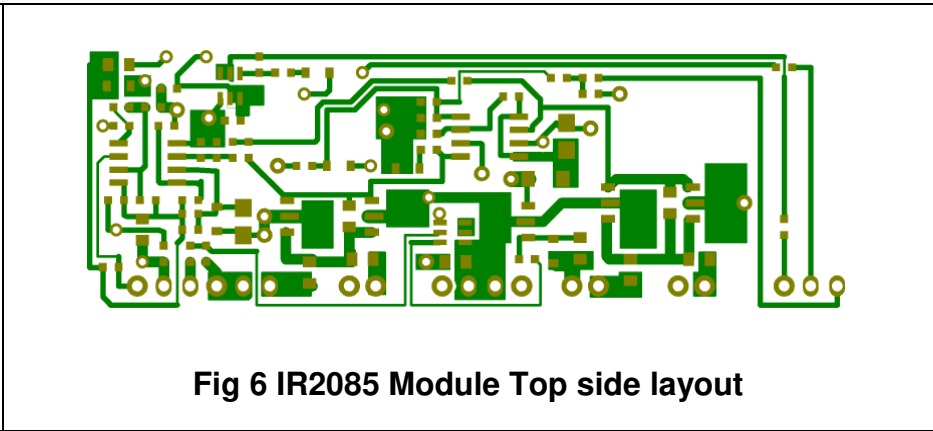
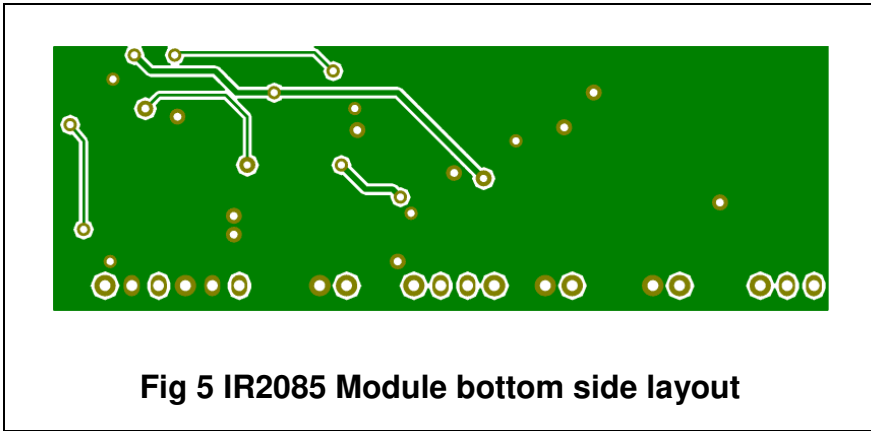
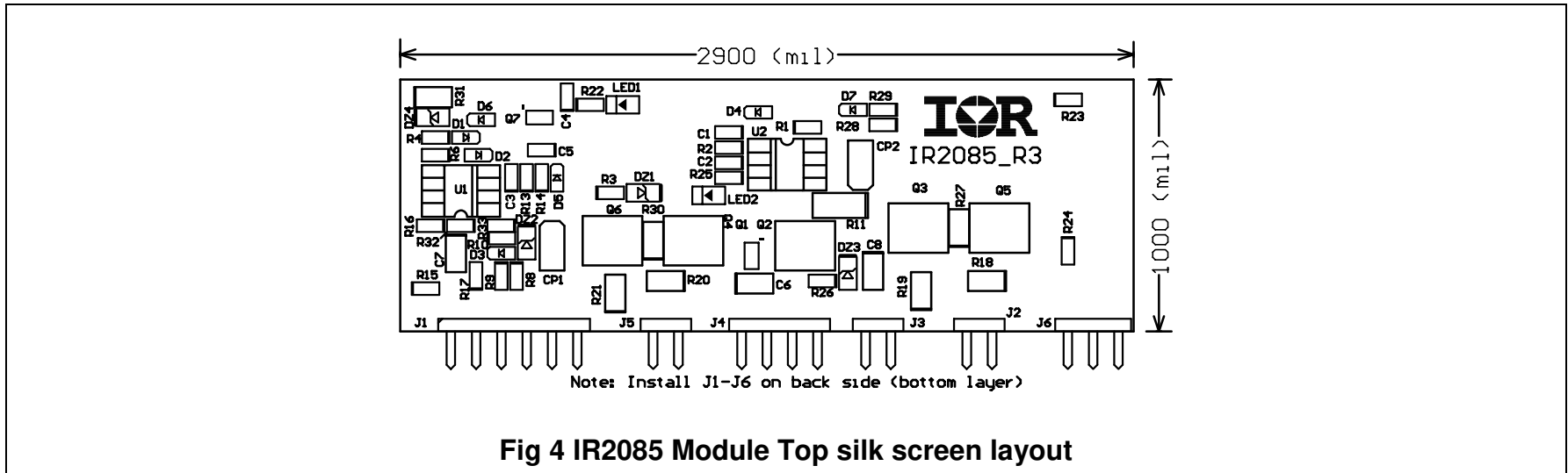
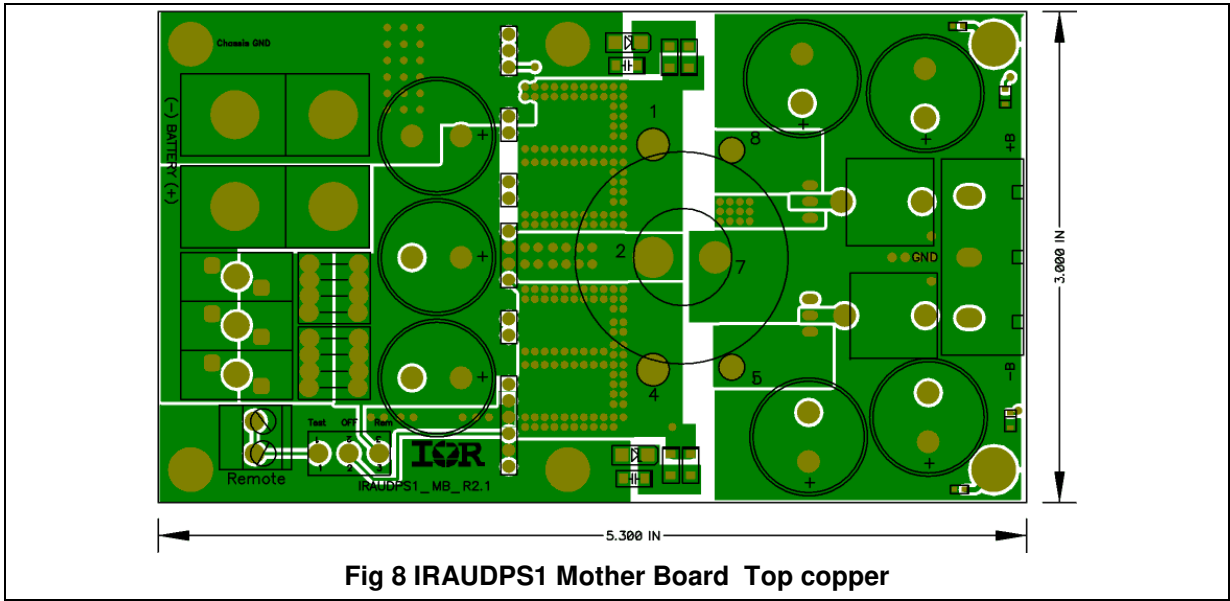
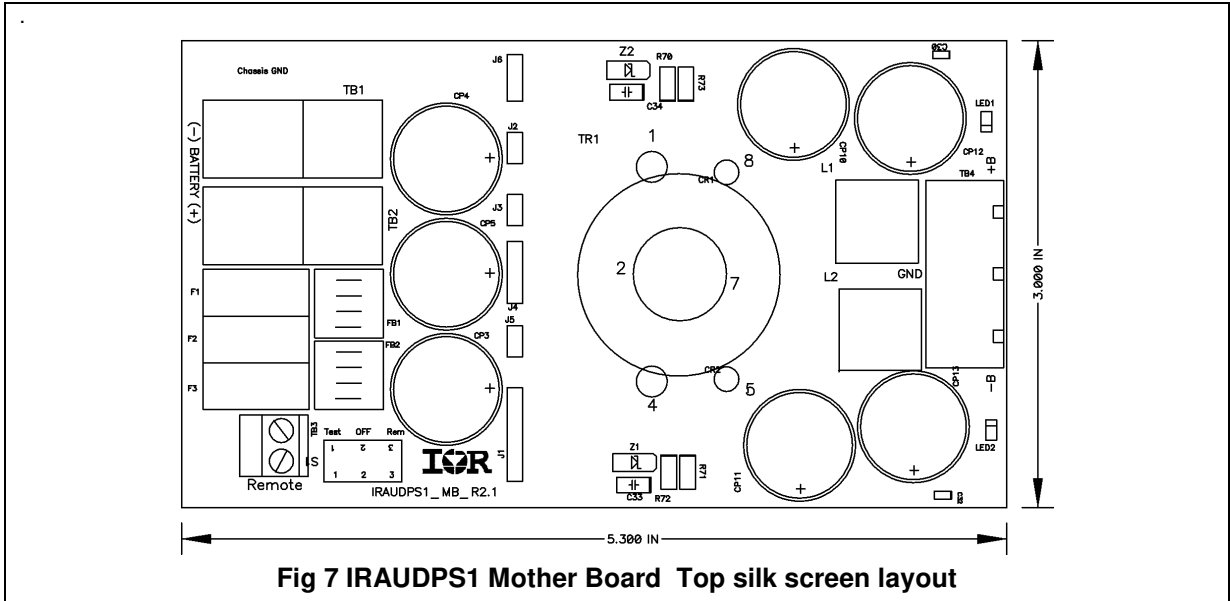
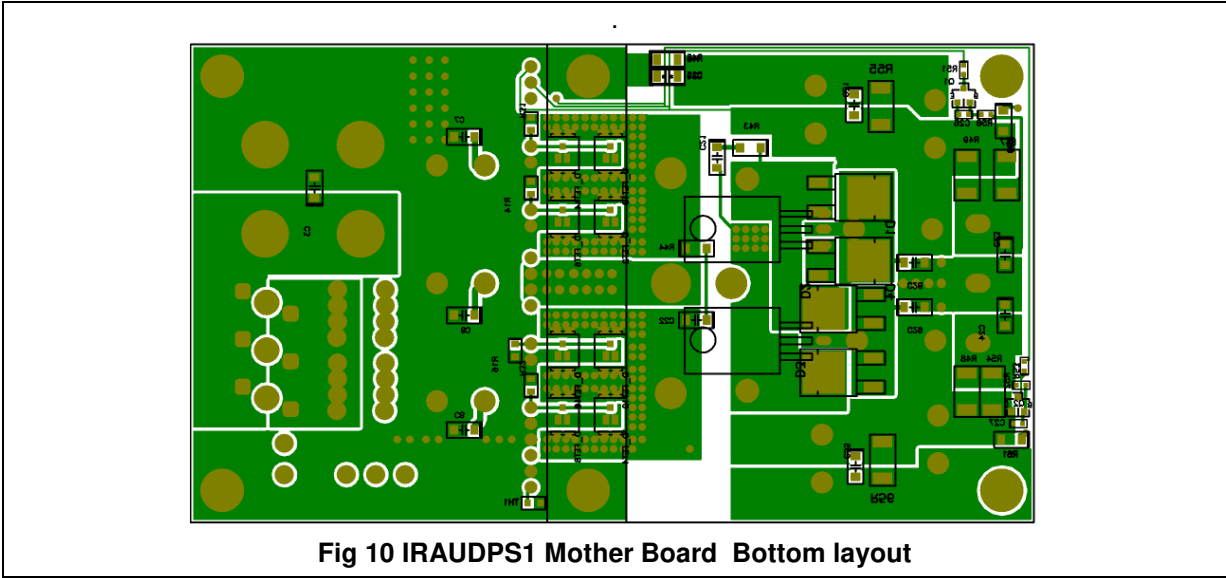
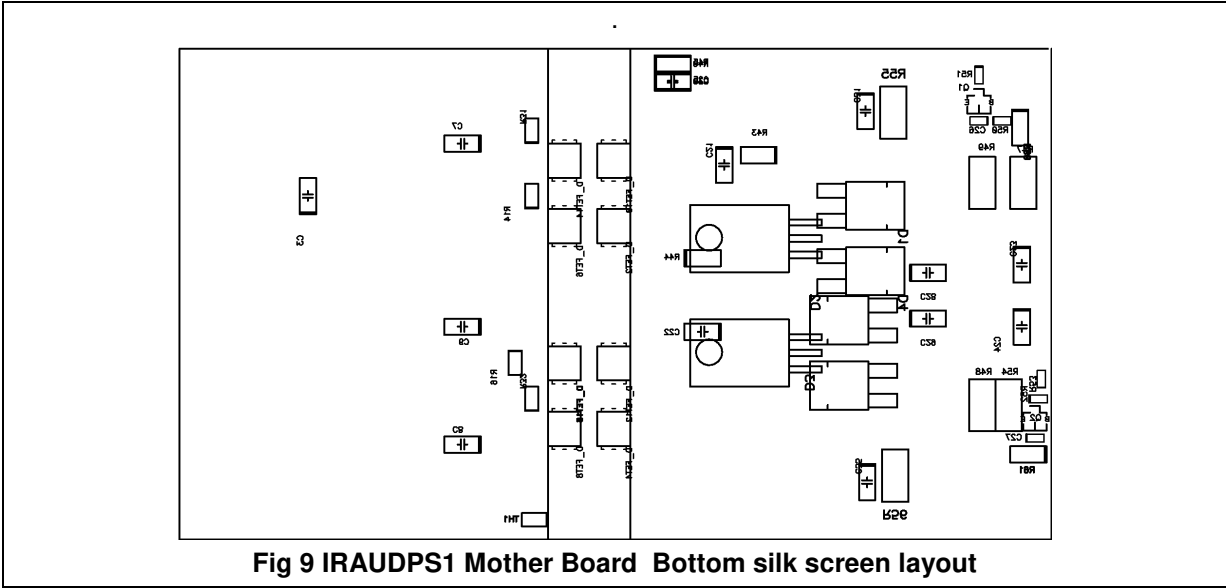

Fig 3 IRAUPS1 Mother Board Schematic







Bill of Materials

Table 4 IRS2085 Module					
Quantity	Value	Description	Designator	Digikey P/N	Vendor
3	0.01uF	CAP 10000PF 50V CERM X7R 0603	C1, C4, C5	PCC1784CT-ND	Panasonic - ECG
1	470pF	CAP CER 470PF 50V 5% C0G 0603	C2	490-1443-1-ND	Murata
1	100pF	CAP CERAMIC 100PF 50V NP0 0603	C3	311-1069-1-ND	Yageo
3	0.1uF	CAP CERM .10UF 50V 20% 0805 SMD	C6, C7, C8	478-3351-1-ND	AVX Corporation
2	10uF	CAP TANTALUM 10UF 16V 10% SMD	CP1, CP2	495-2236-1-ND	Kemet
7	1N4148WT-7	DIODE SWITCH 100V 150MW SOD-523	D1, D2, D3, D4, D5, D6, D7	1N4148WTDICT-ND	Diodes Inc
1	18V	SOD123_Z	DZ1	MMSZ5248BS-FDICT-ND	Diodes Inc
1	5.6V	DIODE ZENER 5.6V 200MW SOD-323	DZ2	UDZSTE-175.6BCT-ND	Rohm
1	12V	DIODE ZENER 200MW 12V SOD323	DZ3	BZT52C12S-TPMSCT-ND	Micro Commercial
1	10V	DIODE ZENER 10V 200MW SOD-323	DZ4	MMSZ5240BSDICT-ND	Diodes Inc
1	Header	Header, 6-Pin, Right Angle	J1,J2,J3,J4,J5,J6	929500E-01-01-ND	3M
1	Red	LED RED ORAN CLEAR THIN 0805 SMD	LED1	160-1422-1-ND	Lite-On Inc
1	Blue	LED 468NM BLUE CLEAR 0805 SMD	LED2	160-1645-1-ND	Lite-On Inc
2	XN04311	TRANS ARRAY PNP/NPN W/RES MINI6P	Q1, Q7	XN0431100LCT-ND	Panasonic - SSG
1	PBSS305NX	TRANS NPN 80V 4.6A SOT-89	Q2	568-4177-1-ND	NXP
2	open	(OPEN) TRANS NPN 80V 4.6A SOT-89	Q3, Q4	568-4177-1-ND	NXP
2	open	(OPEN) TRANS PNP 80V 4A SOT-89	Q5, Q6	568-4178-1-ND	NXP
1	30K	RES 30K OHM 1/10W 5% 0603 SMD	R1	RHM30KGCT-ND	Rohm
1	1k	RES 1K OHM 1/10W 5% 0603 SMD	R2	RHM1.0KGCT-ND	Rohm
11	10k	RES 10K OHM 1/10W 5% 0603 SMD	R3,R6,R9,R14, R15, R16, R17, R23, R24, R32,R33	RHM10KGCT-ND	Rohm
1	1Meg	RES 1.0M OHM 1/10W 5% 0603 SMD	R4	311-1.0MGRCT-ND	Yageo
4	4.7k	RES 4.7K OHM 1/10W 5% 0603 SMD	R8, R13, R22, R25	RHM4.7KGCT-ND	Rohm
1	470k	RES 470K OHM 1/10W 5% 0603 SMD	R10	RHM470KGCT-ND	Rohm
1	2.2	RES 2.2 OHM 1/4W 1% 1206 SMD	R11	P2.2RCT-ND	Panasonic - ECG
4	22	RES 22 OHM 1/8W 5% 0805 SMD	R18, R19, R20, R21	RHM22ARCT-ND	Rohm
2	1k	RES 1.0K OHM 1/10W 5% 0603 SMD	R26, R28	RHM1.0KGCT-ND	Rohm
2	0.0	RES 0.0 OHM 1/8W 5% 0805 SMD	R27, R30	RHM0.0ARCT-ND	Rohm
1	47k	RES 47K OHM 1/10W 5% 0603 SMD	R29	RHM47KGCT-ND	Rohm
1	470	RES 470 OHM 1/8W 5% 0805 SMD	R31	RHM470ARCT-ND	Rohm
1	LM393DR2G	IC COMP DUAL OFFSET LV 8SOIC	U1	LM393DR2GOSCT-ND	ON Semi
1	IR2085	Controller and Gate Driver	U2	IR2085	International Rect

Table 5 IRAUDPS1 Mother Board Bill of Materials

Quantity	Value	Description	Designator	Digikey P/N	Vendor
4	1uF/50V	CAP CER 1UF 50V X7R 1206	C3, C7, C8, C9	490-3908-1-ND	Murata Electronics North
1	1000pF/200V	CAP CER 1000PF 10% 200V X7R 1206	C21	478-1505-1-ND	AVX Corporation
3	2.2nF/100V	CAP CER 2200PF 10% 100V X7R 1206	C22, C33, C34	478-1519-1-ND	AVX Corporation
4	1uF/100V	CAP CER 1UF 100V X7R 1206	C23, C24, C31, C35	490-3909-1-ND	Murata Electronics
4	0.01uF	CAP 10000PF 50V CERM X7R 0603	C26, C27, C30, C32	PCC1784CT-ND	Panasonic - ECG
3	0.1uF/250V	CAP CERAMIC .1UF 250V X7R 1206	C28, C29,C25	399-4674-1-ND	Kemet
3	3300uF/25V	CAP 3300UF 25V ELECT PW RADIAL	CP3, CP4, CP5	493-1842-ND	Nichicon
4	1200uF/63V	CAP 1200UF 63V ELECT PW RADIAL	CP10, CP11, CP12, CP13	493-1958-ND	Nichicon
1	(open)	DIODE Comm Cathode ULT FAST 16A 200V TO220	CR1	MUR1620CTGOS-ND	ON Semiconductor
1	(open)	DIODE Comm Anode ULT FAST 16A 200V TO220	CR2	MUR1620CTRGOS-ND	ON Semiconductor
4	STTH1002CB	DIODE FAST 200V 10A D-PAK	D1, D2, D3, D4	497-3536-5-ND	STMicroelectronics
4	open	Direct-FET MOSFET N-CH 60V 86A	FET2, FET4,FET10,FET12	IRF6648TR1PBFCT-ND	International Rectifier
4	IRF6648	Direct-FET MOSFET N-CH 60V 86A	FET6, FET8, FET14,FET16	IRF6648TR1PBFCT-ND	International Rectifier
3	Fuse Holder	FUSEHOLDR MINI VERT PCB MNT SNGL	F1, F2, F3	F065-ND	Littelfuse Inc
2	FERRITE QUAD LINE 10A	FERRITE 3 LINE 10A 342 OHMS	FB1, FB2	240-2494-ND	Stwart
3	15A	FUSE BLADE 15A/32V MINI FAST-ACT	Fuse1, Fuse2, Fuse3	F992-ND	Littelfuse Inc
1	Module_2085_R2	Control Module	J1,J2, J3, J4,J5,J6	Custom	IR Module_2085_R2 PCB
2	3.3uH/10A	INDUCTOR POWER 3.31UH 11.4A T/H	L1, L2	513-1522-ND	Coiltronics
1	Blue	LED 468NM BLUE CLEAR 0805 SMD	LED1	160-1645-1-ND	Lite-On Inc
1	Blue	LED 468NM BLUE CLEAR 0805 SMD	LED2	160-1645-1-ND	Lite-On Inc
1	MMBT5401	TRANSISTOR PNP 150V SOT-23	Q1	MMBT5401FSCT-ND	Fairchild Semiconductor
1	MMBT5551	TRANSISTOR NPN 160V SOT-23	Q2	MMBT5551FSCT-ND	Fairchild Semiconductor
4	2.2K	RES 2.2K OHM 1/8W 5% 0805 SMD	R14, R16, R31, R32	'RHM2.2KARCT-ND	Rohm
1	100R	RES 100 OHM 1/4W 5% 1206 SMD	R43	311-100ERCT-ND	Yageo
1	10	RES 10 OHM 1/4W 5% 1206 SMD	R44	RHM10ERCT-ND	Rohm
1	1k	RES 1.0K OHM 1/4W 5% 1206 SMD	R45	RHM1.0KERCT-ND	Rohm
4	0.03R	RES .03 OHM 1W 1% 2512 SMD	R47, R48, R49, R54	WSLG-.03CT-ND	Vishay/Dale
4	10k	RES 10K OHM 1/10W 5% 0603 SMD	R50, R51, R52, R53	RHM10KGCT-ND	Rohm
2	2.2k	RES 2.2K OHM 1W 5% 2512 SMD	R55, R56	PT2.2KXCT-ND	Panasonic - ECG
2	22k	RES 22K OHM 1/4W 5% 1206 SMD	R60, R61	RHM22KERCT-ND	Rohm
4	6.2	RES 6.2 OHM 1/4W 5% 1206 SMD	R70, R71, R72, R73	RHM6.2ERCT-ND	Rohm

1	Toggle SW 3Pos	Toggle SW 3Pos	S1	EG2377-ND	E-Switch
2	Gold terminal block	Gold terminal Block #8 AWG	TB1, TB2	070-850	Audio Express
1	TB 2 terminals	CONN TERM BLOCK 2POS 5MM PCB	TB3	277-1022-ND	Phoenix Contact
1	1714984	CONN TERM BLOCK 3POS 9.52MM PCB	TB4	277-1272-ND	Phoenix Contact
1	100K	THERMISTOR 100K OHM NTC 0805 SMD	TH1	490-2451-1-ND	Murata Electronics
1	ZP42915TC	Power Transformer	TR1	Custom TR500-2085	Magnetics
2	SMAZ39-TP	DIODE ZENER 1W 39V SMA	Z1, Z2	SMAZ39-TPMSCT-ND	Micro Commercial Co

Table 6 Mechanical BOM

Quantity	Description	Value	Digikey P/N	Vendor
1	Aluminum Bar heat spreader R2	Aluminum Bar 2085	Custom	China
1	Aluminum Base heat sink R2	Aluminum Bar 2085	Custom 2085	China
1	Print Circuit Board IR2085_MB_R2 .PCB	PCB	IR2085_MB_R1 PCB Assy	China
1	THERMAL PAD .080" 4X4" GAPPAD	THERMAL PAD .080" 4X4" GAPPAD	Ber164-ND	Bergquist
2	(Optional) THERMAL PAD .007" W/ADH	(Optional) THERMAL PAD TO-220	173-7-240A	Wakefield
4	SPACER ROUND 1" #4 SCRW .250" BR	Stand off 0.250"	1454AK-ND	Keystone Electronics
6	NUT HEX 4-40 STAINLESS STEEL	Nut 4-40	H724-ND	Building Fasteners
6	SCREW MACHINE PHILLIPS 4-40X3/4	Screw 4-40X3/4	H350-ND	Building Fasteners
12	WASHER LOCK INTERNAL #4 SS	Washer #4 SS	H729-ND	Building Fasteners

Table 7 Scalable IRAUDPS1 by changing the following components

Component	Notes	250W	IRAUDPS1	1000W
Power Transformer T1	See winding instructions	IR P/N TR-2085-250W	IR P/N TR-2085-500W	IR P/N TR-2085-1000W
Direct FETs	Populate the respective Direct FET by IR6648 as shown on respective model	D_FET6, D_FET16	D_FET6,D_FET8, D_FET14, D_FET16	D_FET6,D_FET8, D_FET14, D_FET2,D_FET4, D_FET10, D_FET12
R47, R48, R47, R54	Short circuit sensitivity	0.06R	0.03R	0.015R
Fuse F1, F2, F3	Input Current	5A	15A	25A
D1, D2, D3, D4	Output Rectifiers	4A	8A	16A
CP3, CP4, CP5	Input Filters	2200uF/25V	3300uF/25V	3900uF/25V

IRAUPS1 Application and connections

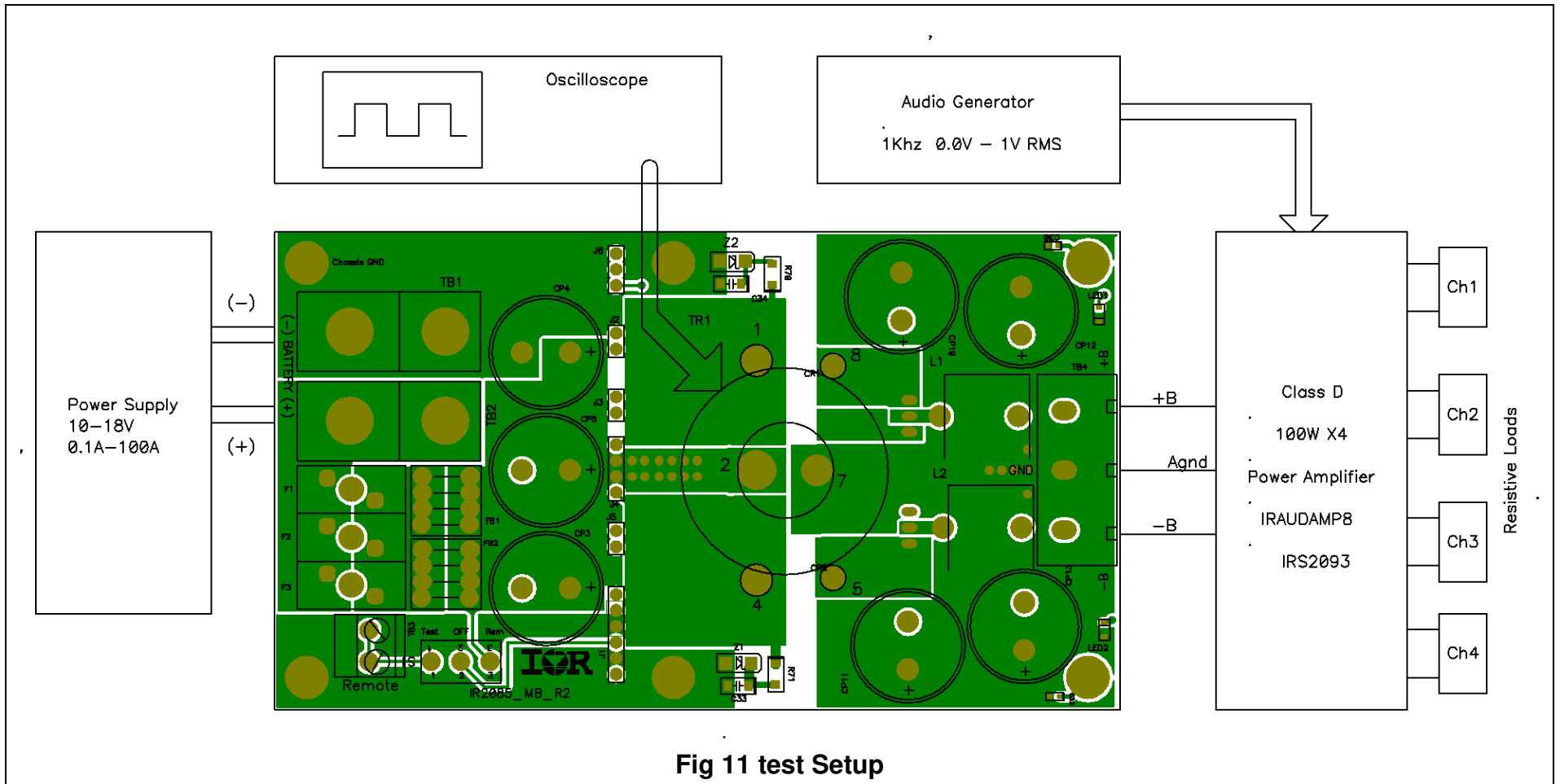

Connector Description

Battery (-)	TB1	Terminal Board for Negative supply source
Battery (+)	TB2	Terminal Board for Positive supply source
+B output	TB4-1	Positive output of +B (+Bus Rail)
Analog GND	TB4-2	Output GND of +B and -B
-B output	TB4-3	Negative output of -B (-Bus Rail)

Switch Description

Remote-OFF-Test

Remote	This position PS1 can be turned ON remotely by vehicle's ACC (Accessory voltage) or vehicle's amplifier
OFF	IRAUDPS1 is always OFF regardless of ACC input
Test	IRAUDPS1 can be turned ON manually or for test purpose

LED Indicator Description

LED1 Red	Indicate the presence of a short circuit condition on +B or -B
LED2 Blue	Indicate the presence of PWM pulses from IR2085
LED3 Blue	Indicate the presence of +B voltage
LED4 Blue	Indicate the presence of -B voltage

Power Source Requirements

The power source shall be capable of delivering 80 Amps with current limited from 1A to 80A during the test; the output voltage shall be variable from 8V to 19V during the test

Test Procedure

1. Pre-adjust the main source power supply to 14.4V and set current limit to 1A
2. Turn on the main source power supply to standby mode
3. On IRAUDPS1 (Unit Under Test) Set the Remote ON switch to OFF (center)
4. Connect an oscilloscope probe on transformer terminals TR1 pin 1
5. **Do NOT Connect the Class D Amp IRAUDAMP8 (IR2093) to +B and -B yet**
6. Connect the resistive load to the class D Amp
7. Set the Audio OSC to 1 kHz and output level to 0.0V

Power up:

8. Turn ON the main source power supply, the input current from the source power supply should be 0.0mA and all LEDs should be OFF
9. Look at LED2 on the IR2085_Module, it should be OFF, then turn ON the Remote-OFF-Test to Test switch while you observe LED2; it will light slightly after turning ON said switch, then LED2 will come fully bright one second after the Remote switch was turned ON (Test position)
10. In the mean time, the figure on the oscilloscope will start from narrow pulses, up to 50% duty cycle and the oscillation frequency shall be 50kHz as shown on Fig 12 and Fig 13 below; This is the soft-start test

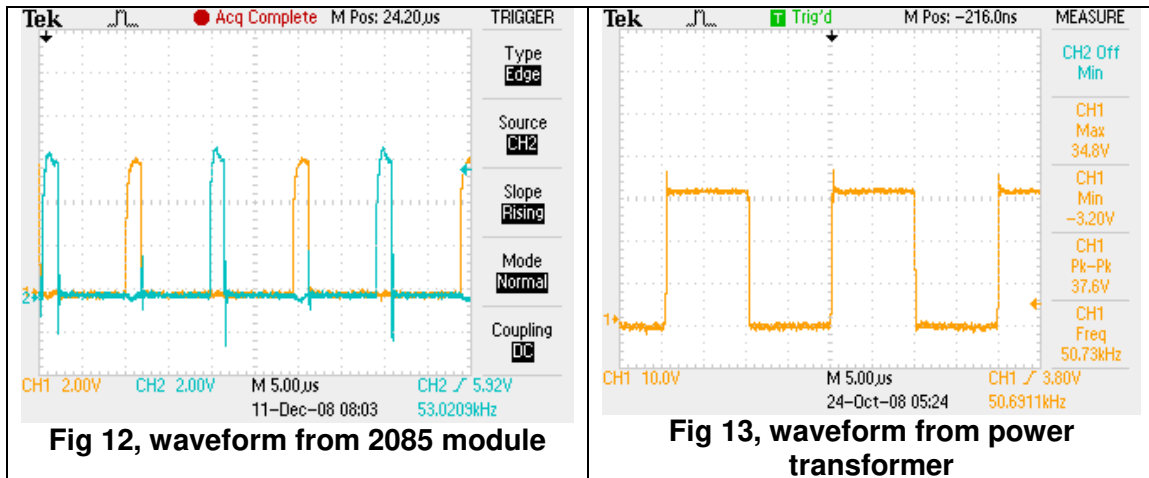

11. The power consumption from the source power supply shall be 0.35A maximum typical is 0.30A and the +B and -B LEDs will turn ON as well
12. Measure the voltage on +B and -B; it will be +/-35V ±1.5V respectively; This is the transformer's windings turns ratio and full-wave rectifiers

UVP Test

13. Decrease the source power supply slowly until it reaches around 8 volts while you observe LED2 or the oscilloscope. LED2 will turn OFF or oscilloscope's pulse will disappear at 8V ±1.5V. Typical is 8.02V

OVP1 Test

14. Increase the source power supply slowly until it reaches around 18V while you observe LED2 or the oscilloscope. LED2 will turn OFF or the oscilloscope's pulse will disappear at 18V ±1.5V. Typical is 18.5V

OVP2 Test

15. Increase the source power supply slowly until it reaches around 16V while you observe LED2 or the oscilloscope;. LED2 will begin blinking or the oscilloscope's pulse will decrease in duty cycle like Fig12 when +B reaches 45V ±2.5V. Typical is 45.0V

SCP Test

16. Adjust the source power supply to 14.4V, then while IRAUPS1 is ON, apply a short circuit between +B and AGnd with external wires, (do not make the SC on the terminal board or it will burn said terminals) LED1 will turn ON and LED2 will be OFF and stay OFF until the Rem-OFF-Test Switch is turned to OFF then ON again; This is the latch of OCP
17. Repeat the last step for -B and GND

Full Load Power Test

18. Turn OFF the IRAUDPS1 and Connect +B and -B to the Class D Amp IRAUDAMP8 (IR2093)
19. Turn ON the IRAUDPS1, the input current from the source power supply should be $0.85A \pm 0.5A$; typical input current is 0.83A with the class D IRAUDAMP8 loaded with no signal input
20. Increase the current limit from the source power supply to 35A
21. Increase slowly the output level from the Audio Oscillator until the Class D amp gets 100W RMS per channel; if resistive loads are 4 Ohms the outputs amplitude from amplifier will be 20V RMS
22. Under these conditions the consumption current from the source power supply shall be 36.6A maximum; this correlates to a 10% loss for each channel and a 20% loss of the IRAUDPS1; this is the power output and efficiency test
23. The output voltages from +B and -B should be $\pm 30V \pm 2.5V$
24. Monitor the transformer waveform; it should be like Fig 14 below
25. The ripple current for +B or -B should be 3V P.P. maximum as shown on Fig 15 below

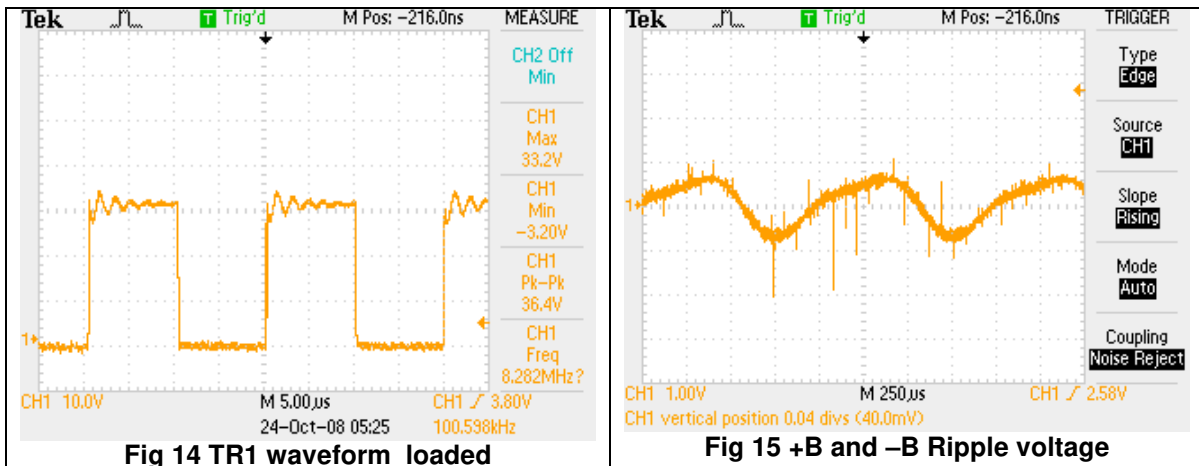

OTP Test

26. Leave the class D amp running with 100W x 4 continuous power until IRAUDPS1 gets hot and trips the shut down level while the temperature on the heat sink is monitored next to the Thermistor sensor. The temperature for shutdown will be $90C \pm 5C$ and the time required to make OTP will be around 30 minutes when tested at ambient temperature
27. The thermal hysteresis shall be 10C and the time to recover it shall be one minute, the time to make shutdown again will be 10 minutes
28. Load Regulation and Efficiency are shown in Fig 16-20 below

Typical Performance

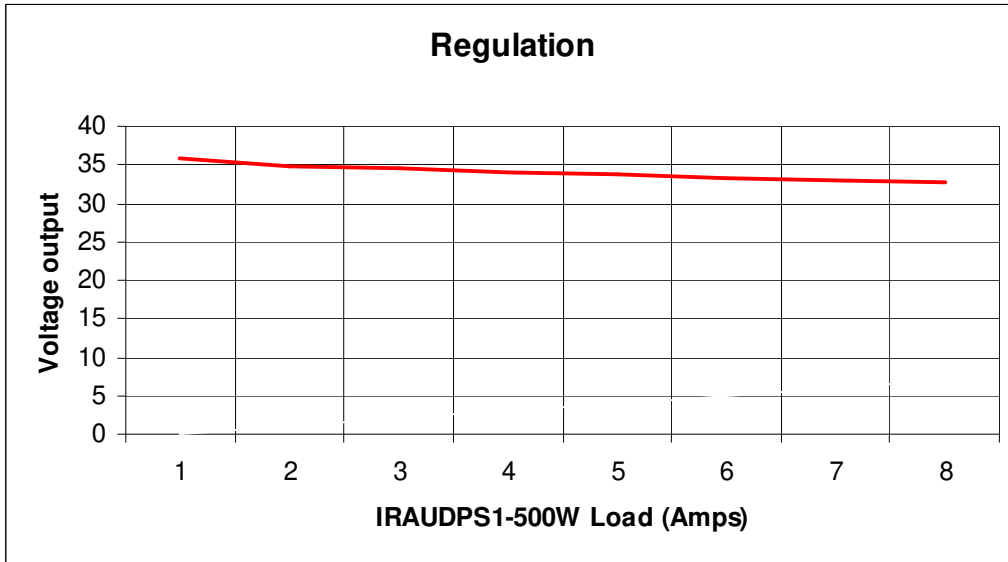

Fig 16

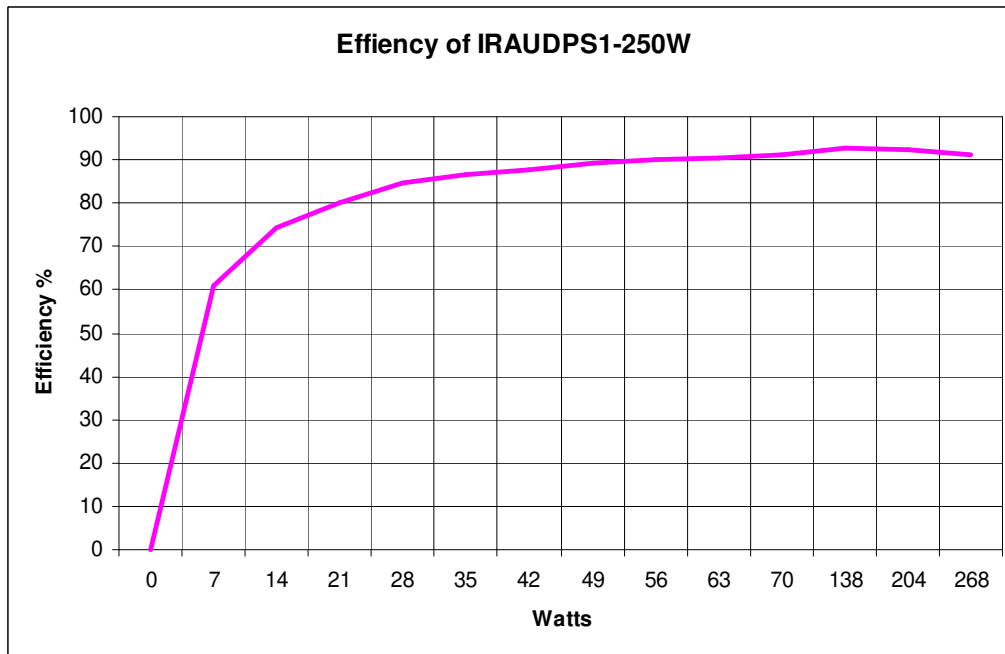

Fig 17

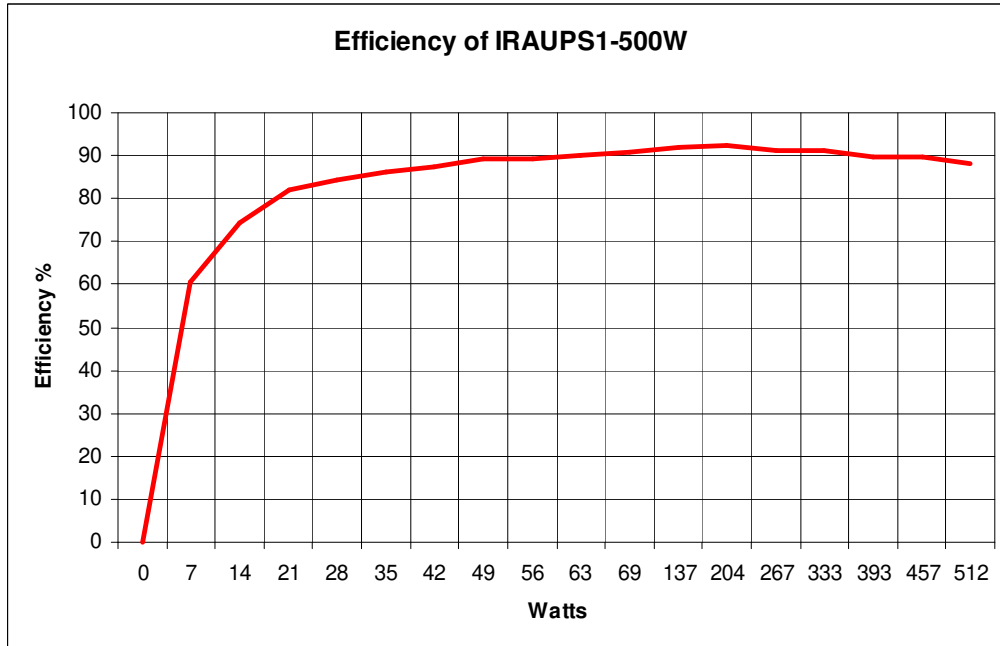

Fig 18

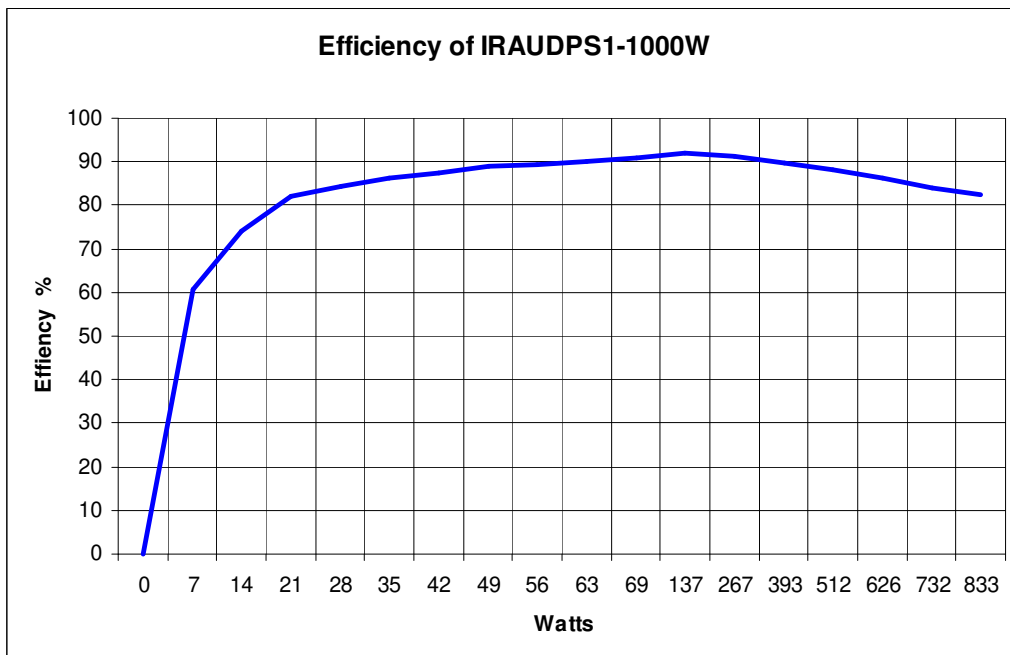

Fig 19

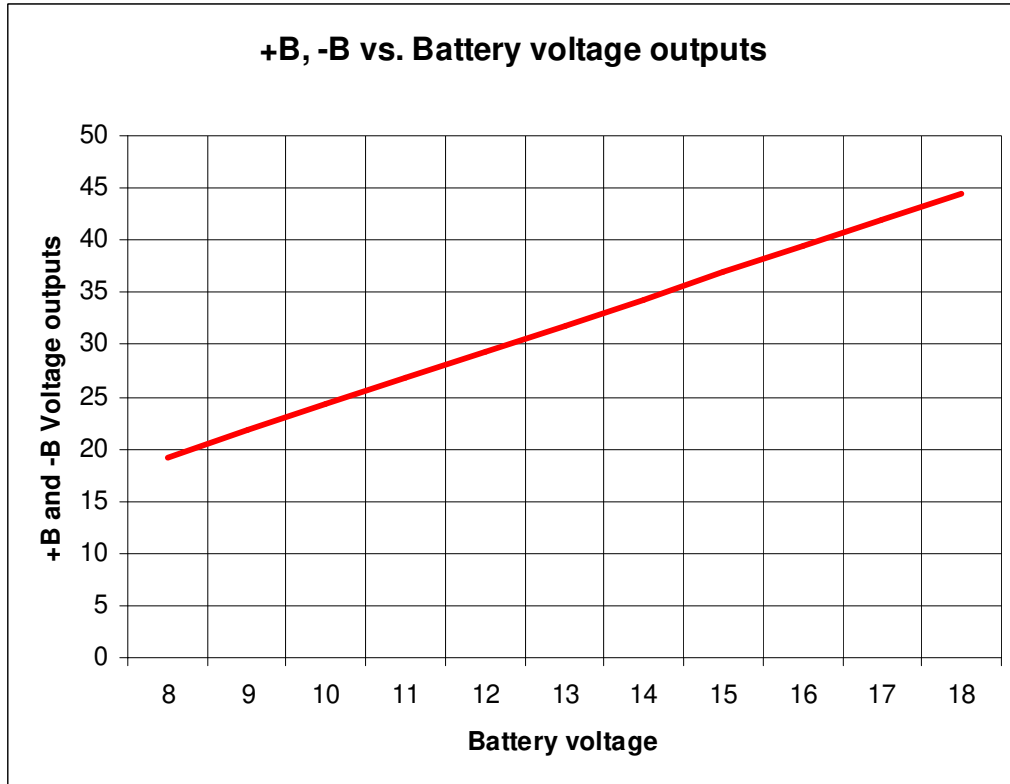
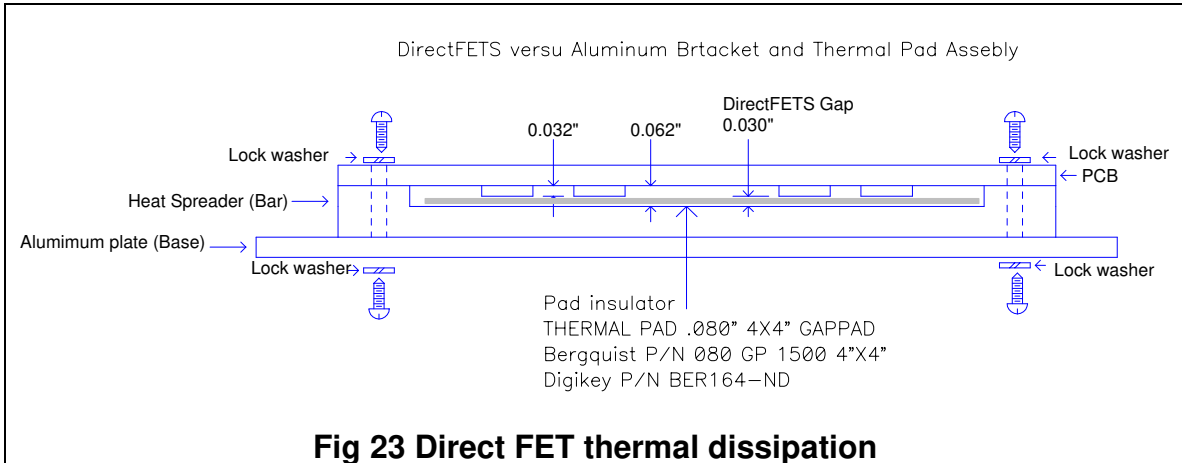
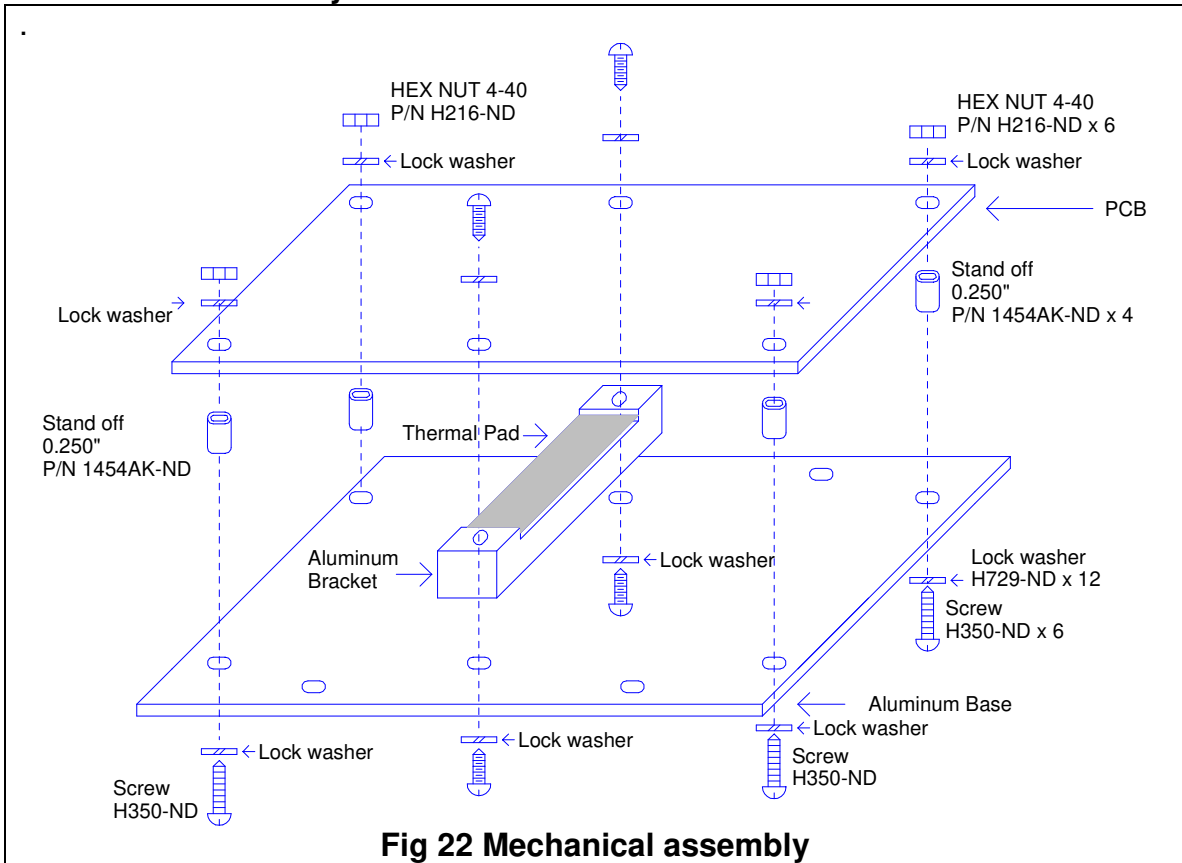
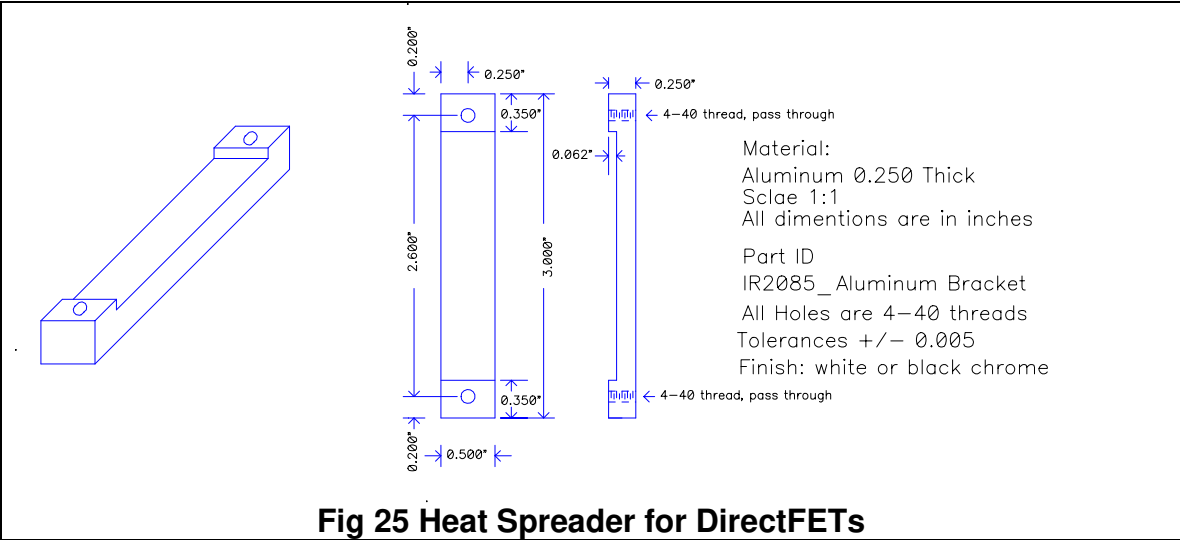
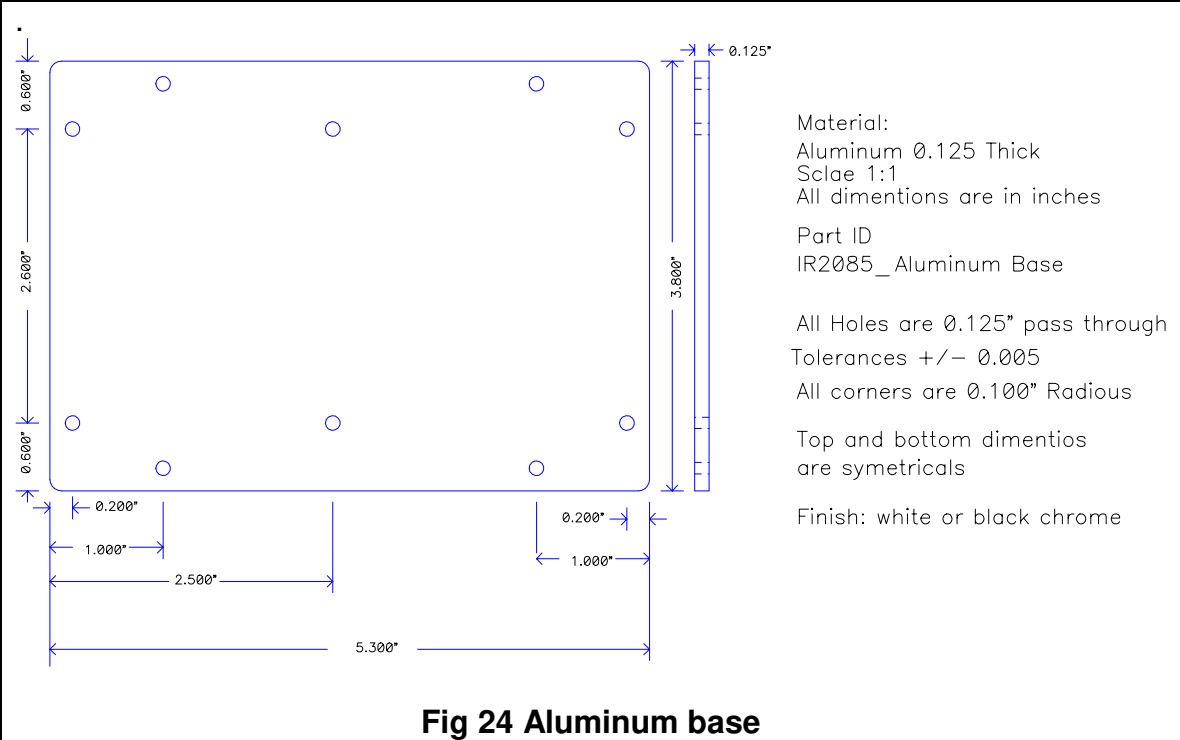

Fig 20

.

IRAUDPS1 Fabrication Drawings
Mechanical assembly





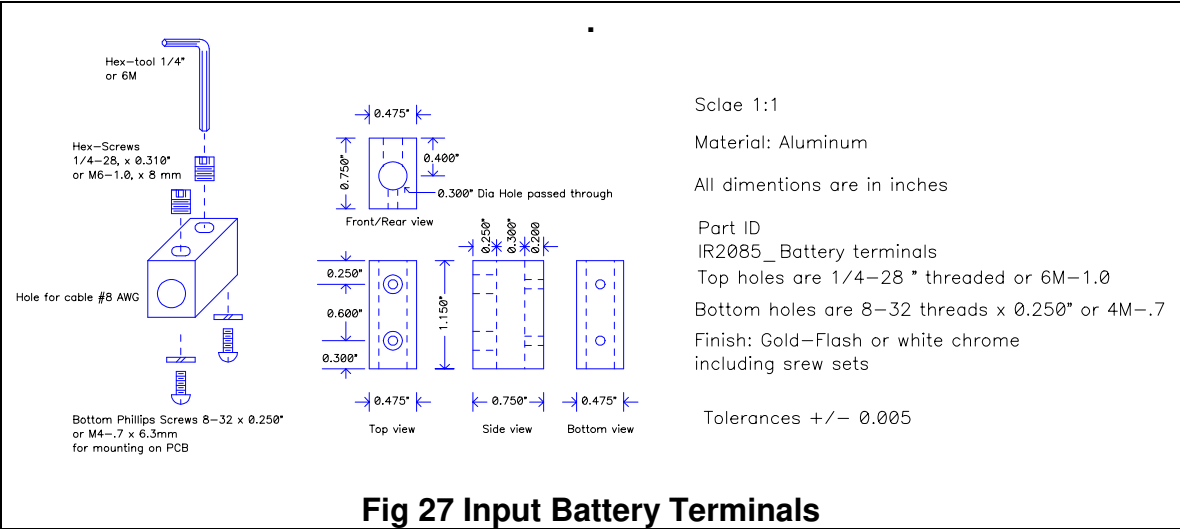
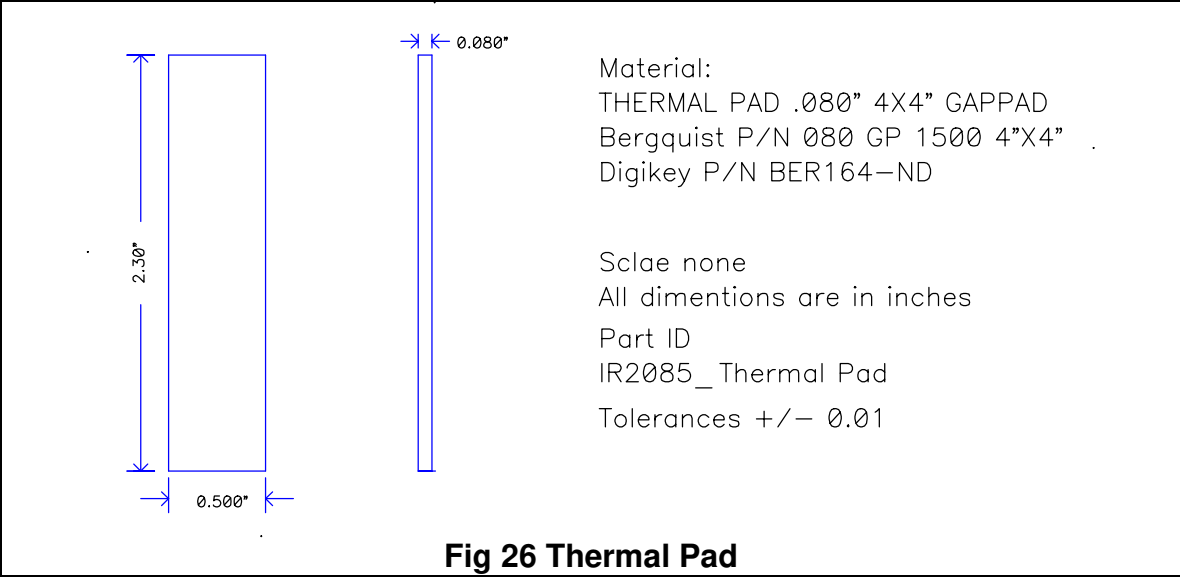

IRAUDPS1 transformer winding instructions

IR Assy P/N IR-TR500-2085-500W

Schematic	Materials required
<p>Fig 28</p>	<p>Core: Magnetics material "P" ZP42915TC</p> <p>Fig 29</p>

	Step No. 1
<p>Fig No. 30</p>	<p>Winding P1:</p> <ol style="list-style-type: none"> 1. Cut 30cm length of 1.0mm gage x 4 wires of magnet wire (AWG 18) 2. Start winding P1 at 0 degrees forward or Clock wise, as shown on Fig 30, start is the top side, and finish is the bottom side 3. Wind 4 turns in parallel at the same time, evenly spaced around the core as shown on Fig 30 4. Leave 4 cm of wire at both ends, spaced ½ inch between ends, as shown on Fig 30

	Step No. 2
<p>Fig No. 31</p>	<p>Winding P2:</p> <ol style="list-style-type: none"> 5. Cut 30cm of 1.0mm gage x 4 wires of magnet wire (AWG 18) 6. Start winding P2 starting on the end of P1, as shown in Fig 31, start is the top side, and finish is the bottom side 7. Wind the 4 at the same time between the spaces of P1 evenly spaced around the core, in the same direction as shown on Fig 31 8. Leave 4 cm of wire at both ends, spaced ½ inch between ends, as shown on Fig 31