



Chipsmall Limited consists of a professional team with an average of over 10 year of expertise in the distribution of electronic components. Based in Hongkong, we have already established firm and mutual-benefit business relationships with customers from,Europe,America and south Asia,supplying obsolete and hard-to-find components to meet their specific needs.

With the principle of “Quality Parts,Customers Priority,Honest Operation,and Considerate Service”,our business mainly focus on the distribution of electronic components. Line cards we deal with include Microchip,ALPS,ROHM,Xilinx,Pulse,ON,Everlight and Freescale. Main products comprise IC,Modules,Potentiometer,IC Socket,Relay,Connector.Our parts cover such applications as commercial,industrial, and automotives areas.

We are looking forward to setting up business relationship with you and hope to provide you with the best service and solution. Let us make a better world for our industry!



Contact us

Tel: +86-755-8981 8866 Fax: +86-755-8427 6832

Email & Skype: info@chipsmall.com Web: www.chipsmall.com

Address: A1208, Overseas Decoration Building, #122 Zhenhua RD., Futian, Shenzhen, China



IRU3137 EVALUATION BOARD USER GUIDE**INTRODUCTION**

The IRU3137 controller IC is designed to provide a low cost and high performance synchronous Buck regulator for on-board DC to DC converter applications. The output voltage can be set as low as 0.8V and higher voltage can be obtained with an external voltage divider. High peak current gate drivers provide fast switching transition for applications requiring high output current in the range of 15A to 20A.

This device features an internal 200KHz oscillator, under-voltage lockout for both V_{CC} and V_C supplies, an external programmable soft-start function as well as output under-voltage detection that latches off the device when an output short is detected.

SPECIFICATION DATAV_{IN} = 5VV_{OUT} = 2.5VI_{OUT} = 15AΔV_{OUT} = 75mVF_S = 200KHz**Supply Voltage:**V_{CC} = V_C = 12V

INPUT/OUTPUT CONNECTIONS

The following is the input/output connections:

Inputs:

JP1: Input (+5V), Gnd

JP4: Input (+12V), Gnd

Outputs:JP2: V_{OUT} (+2.5V)

JP3: Gnd

The connection points is shown in Figure 1. Connect the power supply cables according to this figure, minimize wire lengths to reduce losses in the wire. Test point J1 provides easy connections for the oscilloscope voltage probe to monitor the output voltage.

Note: For proper operation, +5V supply should ramp up first.

CONNECTION DIAGRAM

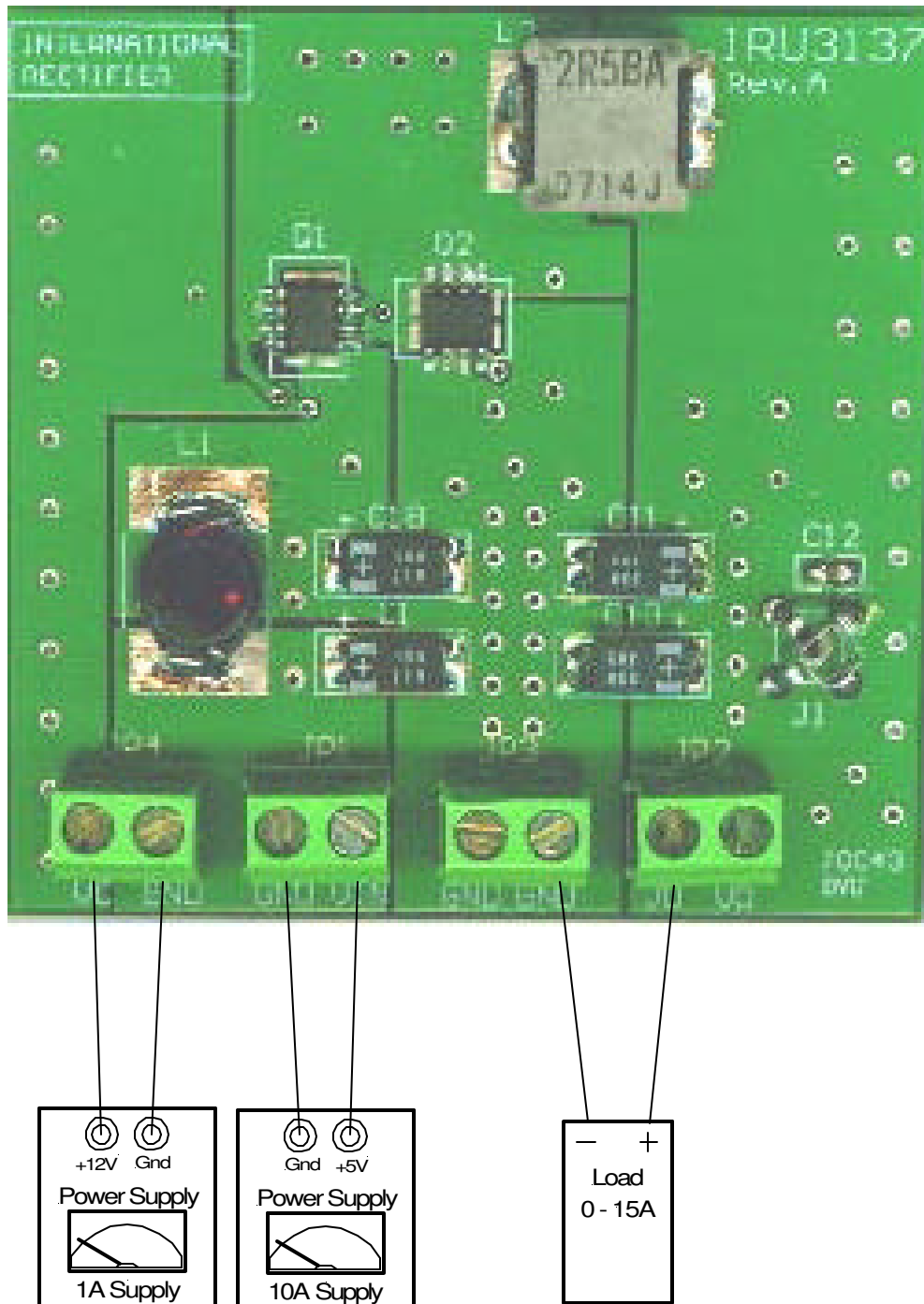

Figure 1 - Connection diagram of evaluation-board for IRU3137.

LAYOUT

The four layers for IRU3137 evaluation board are shown in Figures 2.1-2.4. The layout is designed both for direct FET package and SOIC package for power MOSFETs. The input capacitors are all located close to the MOSFETs. All the decoupling capacitors and feedback components are located close to IC. The feedback re-

sistors are tied to the output voltage at the point of regulation.

The middle layers are dedicated to Power Ground and Analog Ground. Analog Ground is kept separated from the Power Ground and it is connected at a single point as shown in figure 2.3.

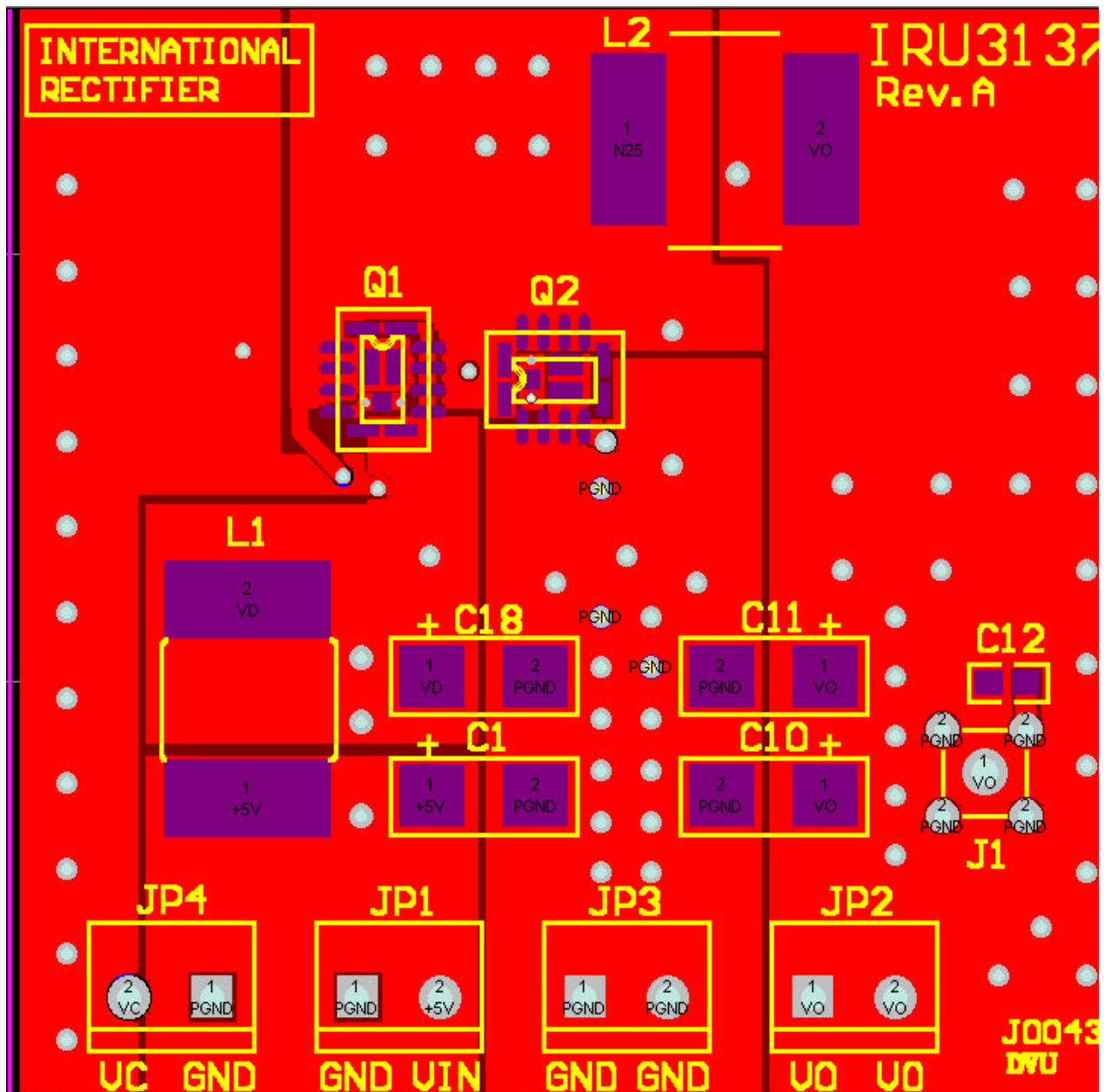

Figure 2.1 - Top layer of evaluation-board for IRU3137.

LAYOUT

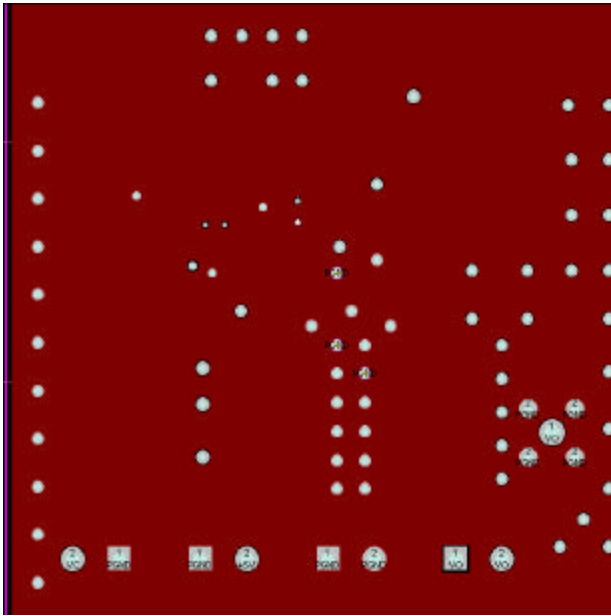

Figure 2.2 - Middle layer 1.

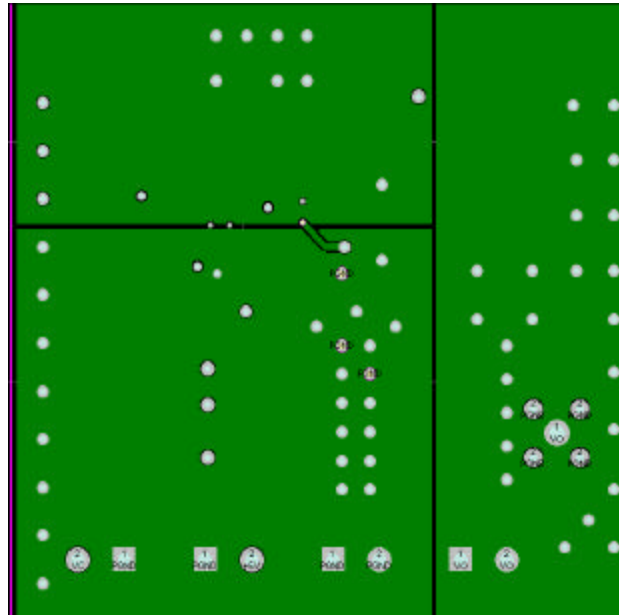

Figure 2.3 - Middle layer 2.

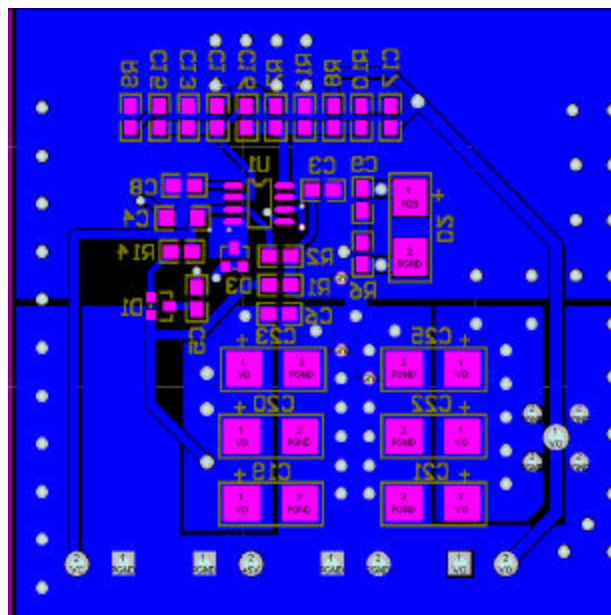

Figure 2.4 - Bottom layer.

SCHEMATIC

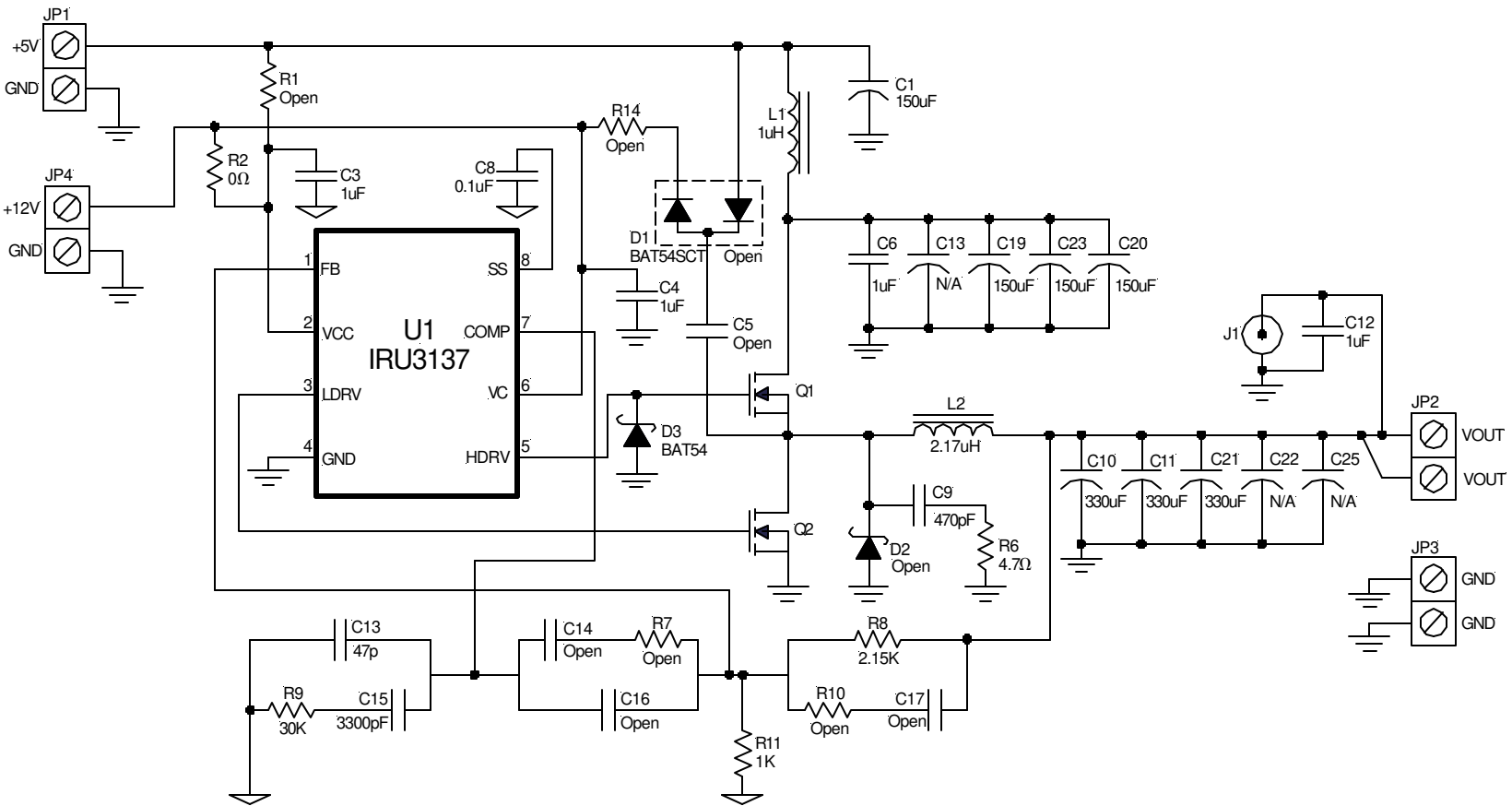

Figure 3 - Schematic of evaluation-board for IRU3137.

BILL OF MATERIAL

Ref Desig	Description	Value	Qty	Part#	Manuf
Q1, Q2	MOSFET	30V, 4mΩ, 15A	2	IRF7832	IR
U1	Controller	Synchronous PWM	1	IRU3137CS	IR
D1, D2	Schottky Diode	Fast Switching	2	N/A Open	IR
D3	Schottky Diode		1	BAT54	IR
L1	Inductor	1μH, 10A	1	D03316P-102HC	Coilcraft
L2	Inductor	2.17μH, 17A	1	ETQP6F2R5BFA	Panasonic
C1,18,19,20,23	Capacitor, Poscap	150μF, 6.3V	5	6TPC150M	Sanyo
C10,11,21	Capacitor, Poscap	330μF, 6.3V	3	6TPC330M	Sanyo
C8	Capacitor	0.1μF, Y5V, 25V	1	ECJ-2VF1E104Z	Panasonic
C15	Capacitor, Ceramic	3300pF, X7R, 50V	1	ECJ-2VB1H332K	Panasonic
C9	Capacitor, Ceramic	470pF, X7R, 50V	1	ECJ-2VC1H471J	Panasonic
C13	Capacitor, Ceramic	47pF, NPO	1	ECJ-2VC1H470J	Panasonic
C3,4,6,12	Capacitor, Ceramic	1μF, Y5V, 16V	4	ECJ-2VF1C105Z	Panasonic
R6	Resistor	4.7Ω, 1%	1		
R8	Resistor	2.15K, 1%	1		
R9	Resistor	30K, 1%	1		
R11	Resistor	1K, 1%	1		
R2	Resistor	0Ω	1		
R1,7,10,14	Resistor	N/A Open	4		
C5,14,16,17,22,25	Capacitor	N/A Open	6		
JP1,JP2,JP3,JP4		2-Pos Terminal	4	ED1973-ND	Digikey
J1			1	131-5031-00	Tektronix

TYPICAL OPERATING CHARACTERISTICS

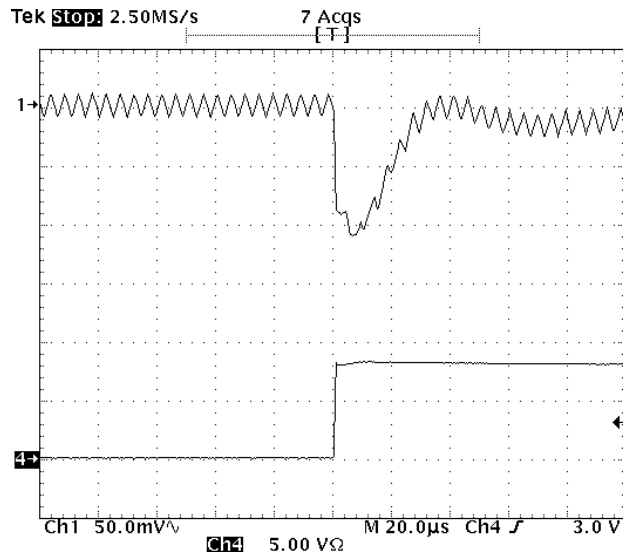

Figure 4 - Transient load response at $I_{OUT}=0A - 8A$.
 Ch1: V_{OUT}
 Ch4: I_{OUT} (5A/div)

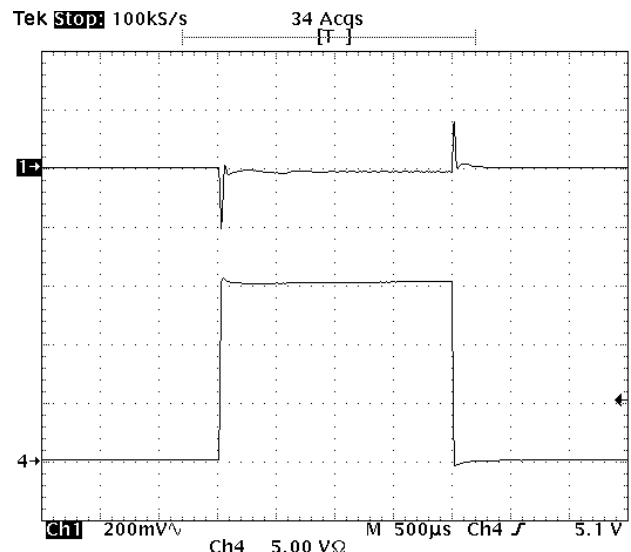

Figure 6 - Transient load response at $I_{OUT}=0A - 15A$.
 Ch1: V_{OUT}
 Ch4: I_{OUT} (5A/div)

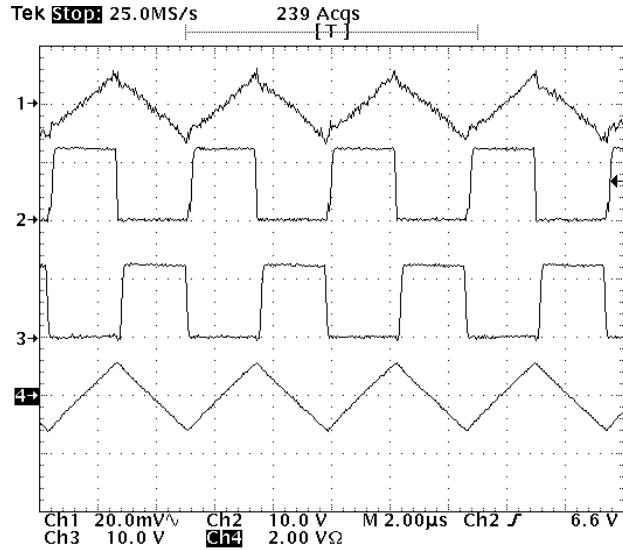

Figure 5 - Normal condition at N/L.
 Ch1: Output Voltage Ripple (20mV/div)
 Ch2: HDrv
 Ch3: LDrv
 Ch4: Inductor Current (2A/div)

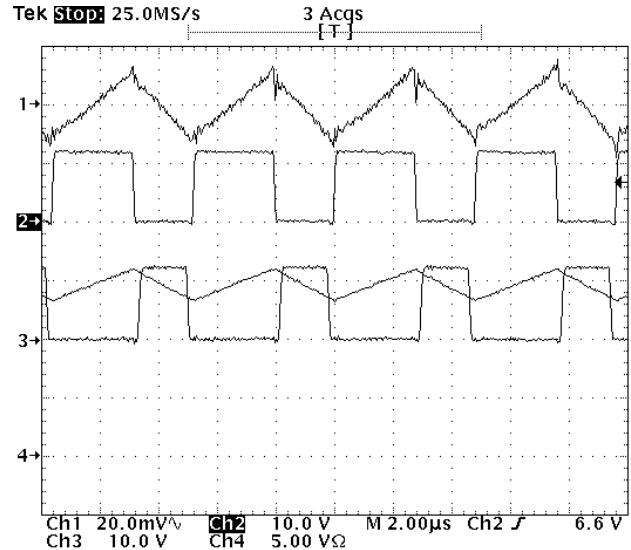

Figure 7 - Normal condition at 15A.
 Ch1: Output Voltage Ripple (20mV/div)
 Ch2: HDrv
 Ch3: LDrv
 Ch4: Inductor Current (5A/div)

TYPICAL OPERATING CHARACTERISTICS

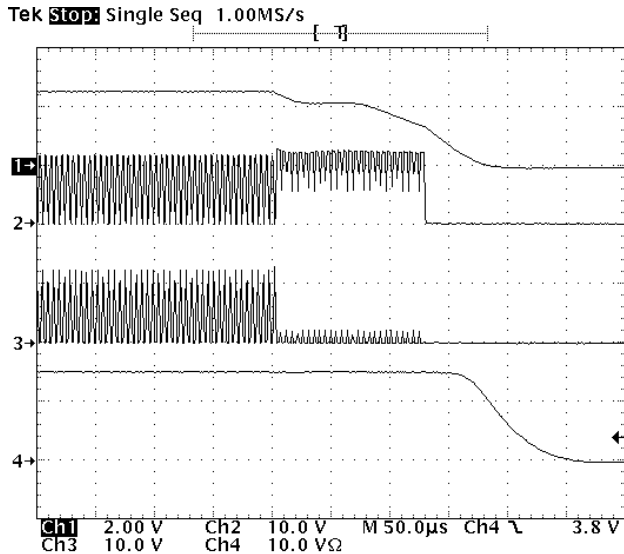

Figure 8 - Shutdown by pulling down the soft-start pin.

- Ch1: V_{OUT}
- Ch2: HDrv
- Ch3: LDrv
- Ch4: I_{OUT} (10A/div)

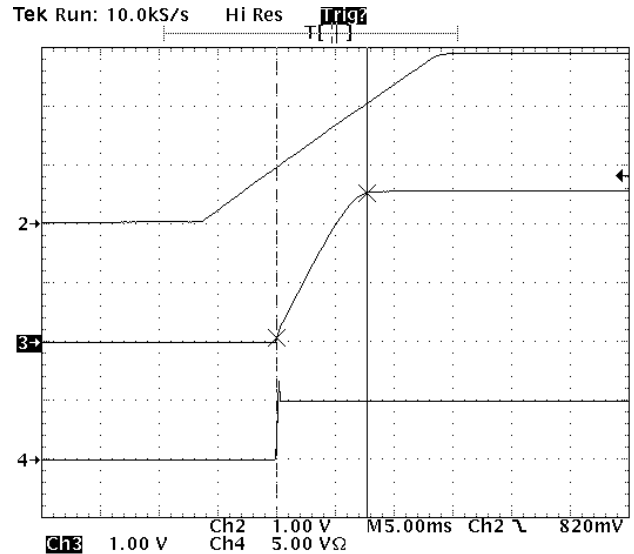

Figure 9 - Start-Up.

- Ch2: V_{SS} (Soft-Start Voltage)
- Ch3: V_{OUT}
- Ch4: I_{OUT} (5A/div)

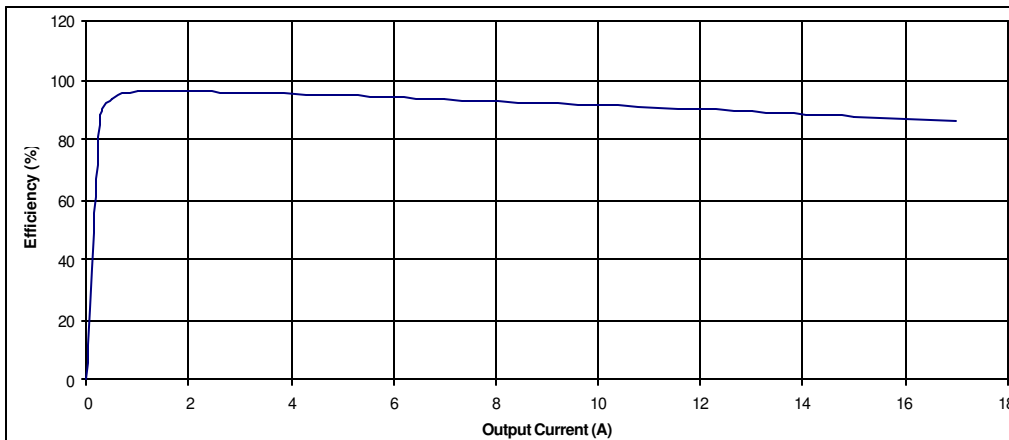

Figure 10 - Application circuit efficiency at ambient temperature.
 5V to 2.5V