



Chipsmall Limited consists of a professional team with an average of over 10 year of expertise in the distribution of electronic components. Based in Hongkong, we have already established firm and mutual-benefit business relationships with customers from,Europe,America and south Asia,supplying obsolete and hard-to-find components to meet their specific needs.

With the principle of "Quality Parts,Customers Priority,Honest Operation,and Considerate Service",our business mainly focus on the distribution of electronic components. Line cards we deal with include Microchip,ALPS,ROHM,Xilinx,Pulse,ON,Everlight and Freescale. Main products comprise IC,Modules,Potentiometer,IC Socket,Relay,Connector.Our parts cover such applications as commercial,industrial, and automotives areas.

We are looking forward to setting up business relationship with you and hope to provide you with the best service and solution. Let us make a better world for our industry!



## Contact us

Tel: +86-755-8981 8866 Fax: +86-755-8427 6832

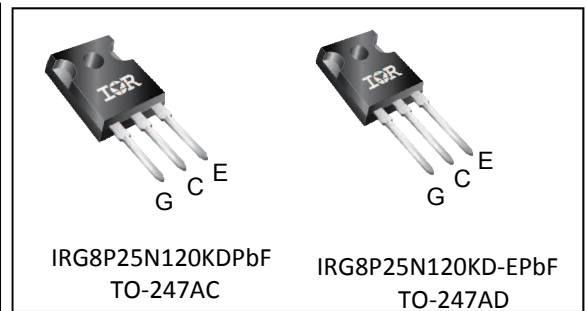
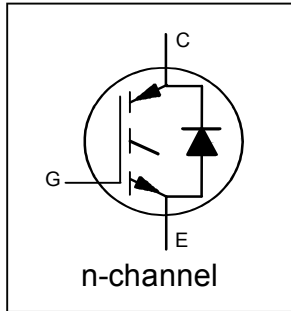
Email & Skype: info@chipsmall.com Web: www.chipsmall.com

Address: A1208, Overseas Decoration Building, #122 Zhenhua RD., Futian, Shenzhen, China



*Insulated Gate Bipolar Transistor with Ultrafast Soft Recovery Diode*

$V_{CES} = 1200V$
$I_C = 25A, T_C = 100^\circ C$
$t_{SC} \geq 10\mu s, T_{J(max)} = 150^\circ C$
$V_{CE(ON)} \text{ typ.} = 1.7V @ I_C = 15A$



**Applications**

- Industrial Motor Drive
- UPS
- Solar Inverters
- Welding

G	C	E
Gate	Collector	Emitter

Features	Benefits
Benchmark Low $V_{CE(ON)}$	High Efficiency in a Motor Drive Applications
10 $\mu s$ Short Circuit SOA	Increases margin for short circuit protection scheme
Positive $V_{CE(ON)}$ Temperature Coefficient	Excellent Current Sharing in Parallel Operation
Square RBSOA and high $I_{LM}$ - rating	Rugged Transient Performance
Lead-Free, RoHS compliant	Environmentally friendly

Base part number	Package Type	Standard Pack		Orderable Part Number
		Form	Quantity	
IRG8P25N120KDPbF	TO-247AC	Tube	25	IRG8P25N120KDPbF
IRG8P25N120KD-EPbF	TO-247AD	Tube	25	IRG8P25N120KD-EPbF

**Absolute Maximum Ratings**

	Parameter	Max.	Units
$V_{CES}$	Collector-to-Emitter Voltage	1200	V
$I_C @ T_C = 25^\circ C$	Continuous Collector Current (Silicon Limited)	40	A
$I_C @ T_C = 100^\circ C$	Continuous Collector Current	25	
$I_{CM}$	Pulse Collector Current (see fig. 2)	45	
$I_{LM}$	Clamped Inductive Load Current (see fig. 3)①	60	
$I_F @ T_C = 25^\circ C$	Diode Continuous Forward Current	25	
$I_F @ T_C = 100^\circ C$	Diode Continuous Forward Current	12	
$I_{FM}$	Diode Maximum Forward Current ⑤	60	
$V_{GE}$	Continuous Gate-to-Emitter Voltage	$\pm 30$	V
$P_D @ T_C = 25^\circ C$	Maximum Power Dissipation	180	W
$P_D @ T_C = 100^\circ C$	Maximum Power Dissipation	70	
$T_J$ $T_{STG}$	Operating Junction and Storage Temperature Range	-40 to +150	C
	Soldering Temperature, for 10 sec.	300 (0.063 in. (1.6mm) from case)	
	Mounting Torque, 6-32 or M3 Screw	10 lbf·in (1.1 N·m)	

**Thermal Resistance**

	Parameter	Min.	Typ.	Max.	Units
$R_{\theta JC}$ (IGBT)	Thermal Resistance Junction-to-Case-(each IGBT) ②	—	—	0.7	$^\circ C/W$
$R_{\theta JC}$ (Diode)	Thermal Resistance Junction-to-Case-(each Diode) ②	—	—	1.5	
$R_{\theta CS}$	Thermal Resistance, Case-to-Sink (flat, greased surface)	—	0.24	—	
$R_{\theta JA}$	Thermal Resistance, Junction-to-Ambient (typical socket mount)	—	40	—	

**Electrical Characteristics @ T<sub>J</sub> = 25°C (unless otherwise specified)**

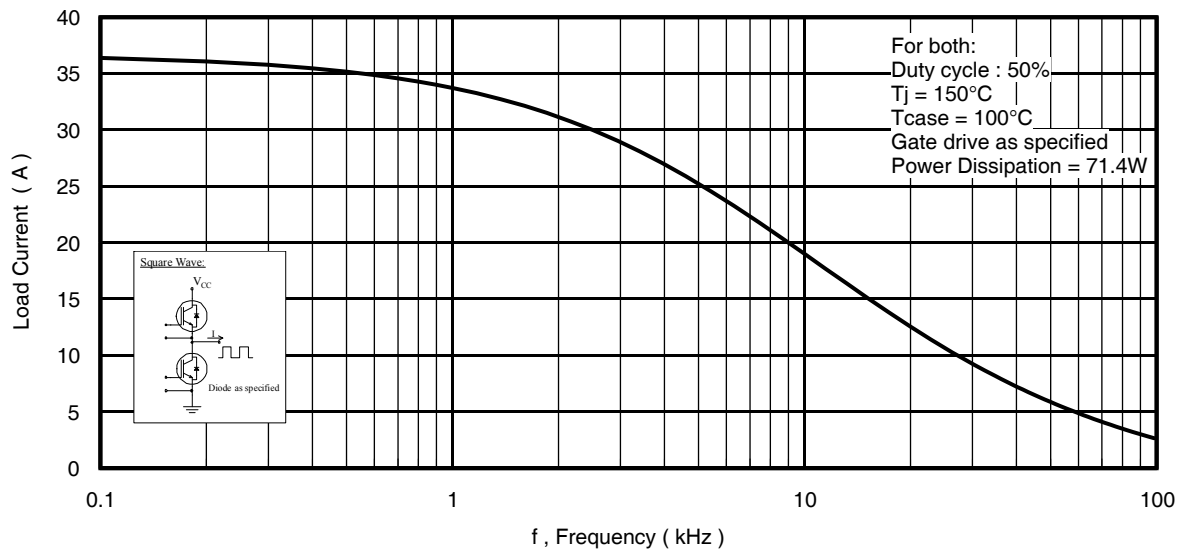
	Parameter	Min.	Typ.	Max.	Units	Conditions
V <sub>(BR)CES</sub>	Collector-to-Emitter Breakdown Voltage	1200	—	—	V	V <sub>GE</sub> = 0V, I <sub>C</sub> = 250μA ③
ΔV <sub>(BR)CES</sub> /ΔT <sub>J</sub>	Temperature Coeff. of Breakdown Voltage	—	0.92	—	V/°C	V <sub>GE</sub> = 0V, I <sub>C</sub> = 1mA (25°C-150°C)
V <sub>CE(on)</sub>	Collector-to-Emitter Saturation Voltage	—	1.7	2.0	V	I <sub>C</sub> = 15A, V <sub>GE</sub> = 15V, T <sub>J</sub> = 25°C
		—	2.0	—		I <sub>C</sub> = 15A, V <sub>GE</sub> = 15V, T <sub>J</sub> = 150°C
V <sub>GE(th)</sub>	Gate Threshold Voltage	5.0	—	6.5	V	V <sub>CE</sub> = V <sub>GE</sub> , I <sub>C</sub> = 600μA
ΔV <sub>GE(th)</sub> /ΔT <sub>J</sub>	Threshold Voltage Temperature Coeff.	—	-16	—	mV/°C	V <sub>CE</sub> = V <sub>GE</sub> , I <sub>C</sub> = 600μA (25°C-150°C)
g <sub>fe</sub>	Forward Transconductance	—	8.5	—	S	V <sub>CE</sub> = 50V, I <sub>C</sub> = 15A, PW = 20μs
I <sub>CES</sub>	Collector-to-Emitter Leakage Current	—	1	30	μA	V <sub>GE</sub> = 0V, V <sub>CE</sub> = 1200V
		—	1	—	mA	V <sub>GE</sub> = 0V, V <sub>CE</sub> = 1200V, T <sub>J</sub> = 150°C
I <sub>GES</sub>	Gate-to-Emitter Leakage Current	—	—	±100	nA	V <sub>GE</sub> = ±30V
V <sub>F</sub>	Diode Forward Voltage Drop	—	2.1	2.7	V	I <sub>F</sub> = 15A
		—	2.4	—		I <sub>F</sub> = 15A, T <sub>J</sub> = 150°C

**Switching Characteristics @ T<sub>J</sub> = 25°C (unless otherwise specified)**

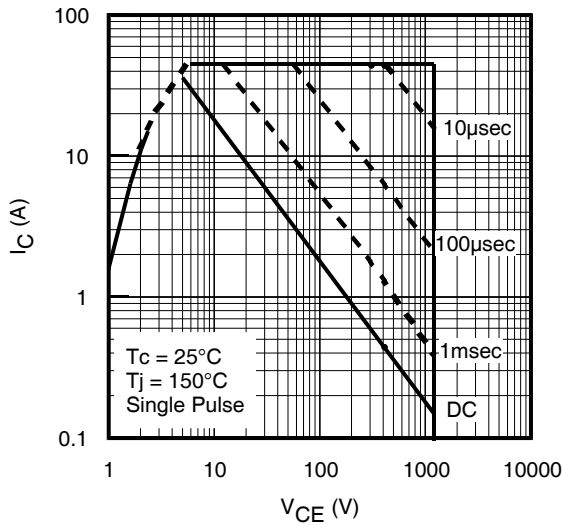
	Parameter	Min.	Typ.	Max④	Units	Conditions
Q <sub>g</sub>	Total Gate Charge (turn-on)	—	90	135	nC	I <sub>C</sub> = 15A V <sub>GE</sub> = 15V V <sub>CC</sub> = 600V
Q <sub>ge</sub>	Gate-to-Emitter Charge (turn-on)	—	5.0	—		
Q <sub>gc</sub>	Gate-to-Collector Charge (turn-on)	—	60	—		
E <sub>on</sub>	Turn-On Switching Loss	—	0.8	—	mJ	I <sub>C</sub> = 15A, V <sub>CC</sub> = 600V, V <sub>GE</sub> = 15V R <sub>G</sub> = 10Ω, T <sub>J</sub> = 25°C
E <sub>off</sub>	Turn-Off Switching Loss	—	0.9	—		
E <sub>total</sub>	Total Switching Loss	—	1.7	—		
t <sub>d(on)</sub>	Turn-On delay time	—	20	—	ns	Energy losses include tail & diode reverse recovery ⑥
t <sub>r</sub>	Rise time	—	20	—		
t <sub>d(off)</sub>	Turn-Off delay time	—	170	—		
t <sub>f</sub>	Fall time	—	190	—		
E <sub>on</sub>	Turn-On Switching Loss	—	1.3	—	mJ	I <sub>C</sub> = 15A, V <sub>CC</sub> = 600V, V <sub>GE</sub> = 15V R <sub>G</sub> = 10Ω, T <sub>J</sub> = 150°C
E <sub>off</sub>	Turn-Off Switching Loss	—	1.7	—		
E <sub>total</sub>	Total Switching Loss	—	3.0	—		
t <sub>d(on)</sub>	Turn-On delay time	—	20	—	ns	Energy losses include tail & diode reverse recovery ⑥
t <sub>r</sub>	Rise time	—	20	—		
t <sub>d(off)</sub>	Turn-Off delay time	—	260	—		
t <sub>f</sub>	Fall time	—	325	—		
C <sub>ies</sub>	Input Capacitance	—	1800	—	pF	V <sub>GE</sub> = 0V V <sub>CC</sub> = 30V f = 1.0Mhz
C <sub>oes</sub>	Output Capacitance	—	90	—		
C <sub>res</sub>	Reverse Transfer Capacitance	—	45	—		
RBSOA	Reverse Bias Safe Operating Area	FULL SQUARE				T <sub>J</sub> = 150°C, I <sub>C</sub> = 60A V <sub>CC</sub> = 960V, V <sub>p</sub> ≤ 1200V V <sub>GE</sub> = +20V to 0V
SCSOA	Short Circuit Safe Operating Area	10	—	—	μs	T <sub>J</sub> = 150°C, V <sub>CC</sub> = 600V, V <sub>p</sub> ≤ 1200V V <sub>GE</sub> = +15V to 0V
E <sub>rec</sub>	Reverse Recovery Energy of the Diode	—	0.7	—	mJ	T <sub>J</sub> = 150°C
t <sub>rr</sub>	Diode Reverse Recovery Time	—	70	—	ns	V <sub>CC</sub> = 600V, I <sub>F</sub> = 15A
I <sub>rr</sub>	Peak Reverse Recovery Current	—	29	—	A	V <sub>GE</sub> = 15V, R <sub>G</sub> = 10Ω

**Notes:**

- ① V<sub>CC</sub> = 80% (V<sub>CES</sub>), V<sub>GE</sub> = 20V.
- ② R<sub>θ</sub> is measured at T<sub>J</sub> of approximately 90°C.
- ③ Refer to AN-1086 for guidelines for measuring V<sub>(BR)CES</sub> safely.
- ④ Maximum limits are based on statistical sample size characterization.
- ⑤ Pulse width limited by max. junction temperature.
- ⑥ Values influenced by parasitic L and C in measurement.

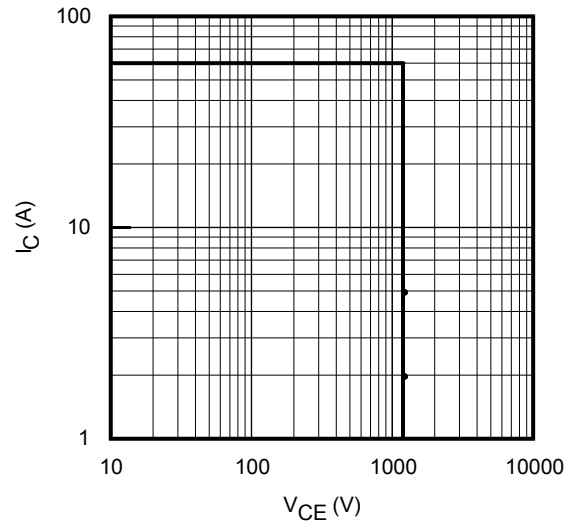


**Fig. 1 - Typical Load Current vs. Frequency**  
(Load Current = IRMS of fundamental)



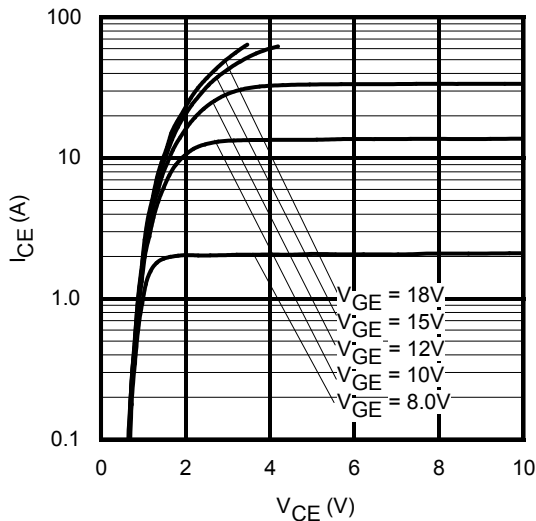
**Fig. 2 - Forward SOA**

$T_C = 25^\circ\text{C}; T_J \leq 150^\circ\text{C}; V_{GE} = 15\text{V}$

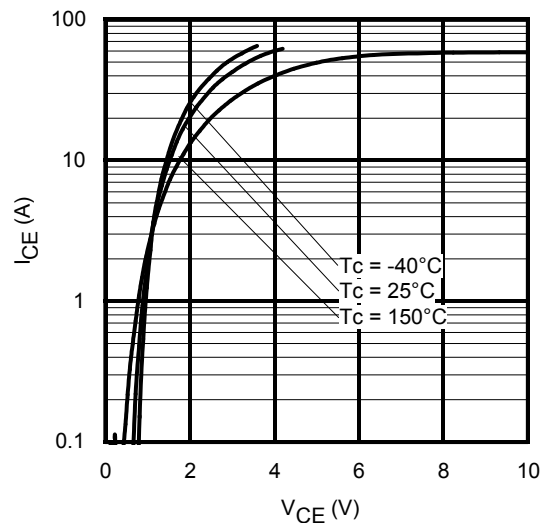


**Fig. 3 - Reverse Bias SOA**

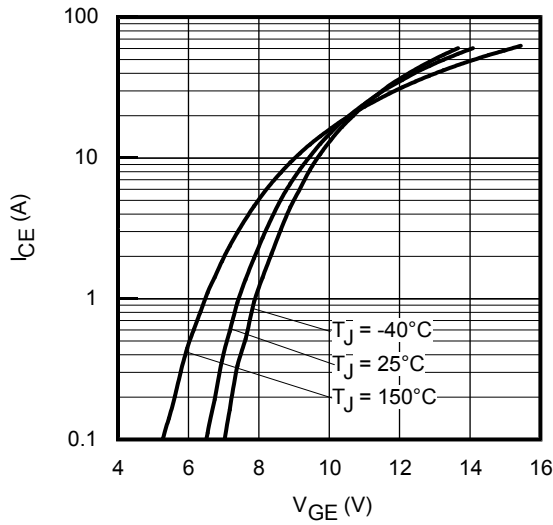
$T_J = 150^\circ\text{C}; V_{GE} = 20\text{V}$



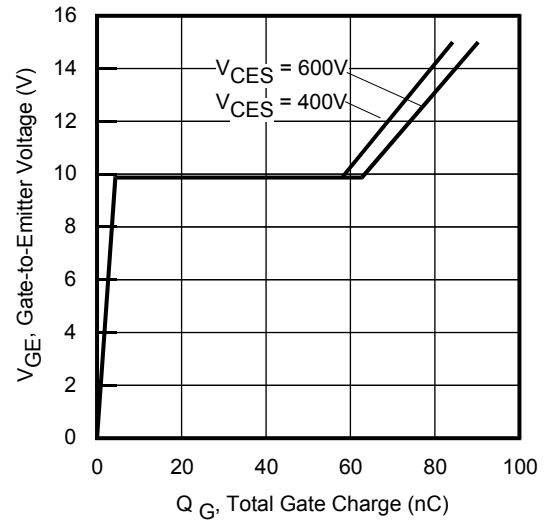
**Fig. 4 - Typ. IGBT Output Characteristics**  
 $T_J = 25^\circ\text{C}; t_p = 20\mu\text{s}$



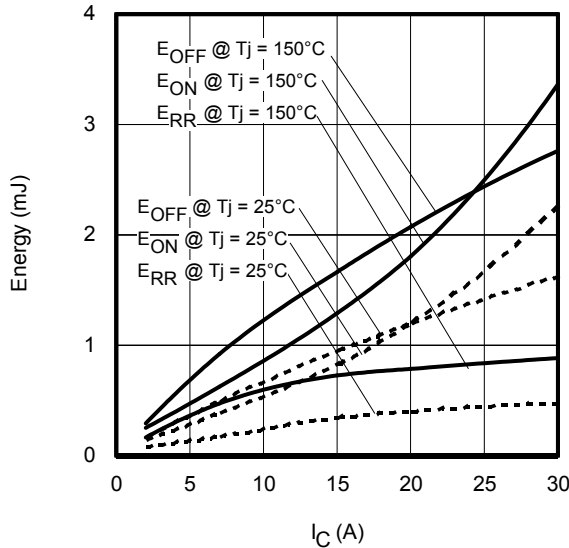
**Fig. 5 - Typ. IGBT Saturation Voltage**  
 $V_{GE} = 15\text{V}; t_p = 20\mu\text{s}$



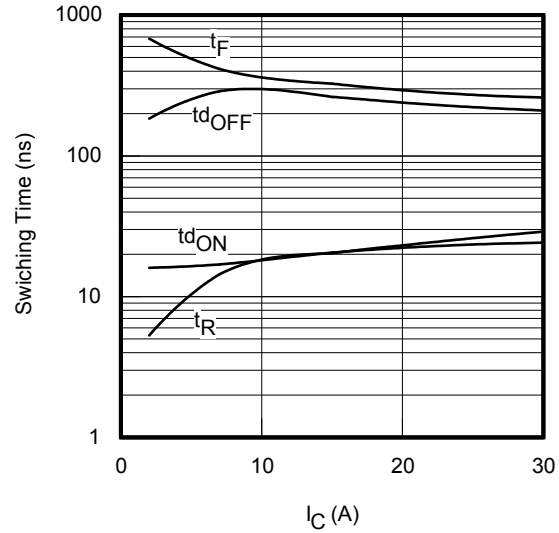
**Fig. 6 - Typ. Transfer Characteristics**  
 $V_{CE} = 50V$ ;  $t_p = 20\mu s$



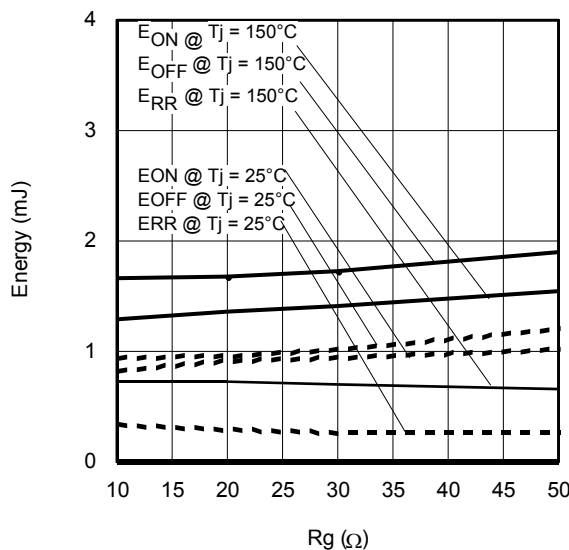
**Fig. 7 - Typical Gate Charge vs.  $V_{GE}$**   
 $I_{CE} = 15A$



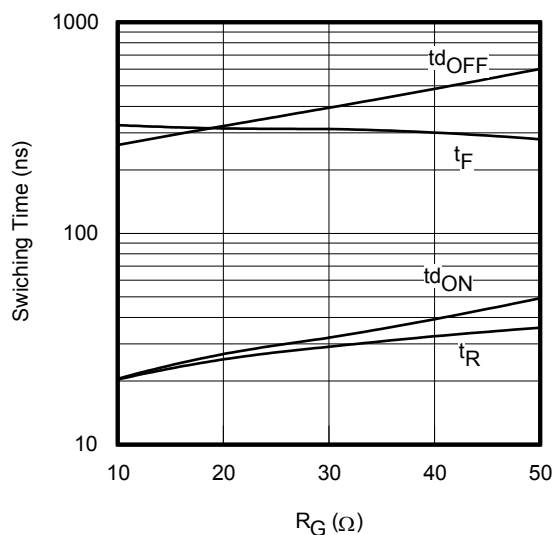
**Fig. 8 - Typ. Energy Loss vs.  $I_C$**   
 $V_{CE} = 600V$ ,  $R_G = 10\Omega$ ;  $V_{GE} = 15V$



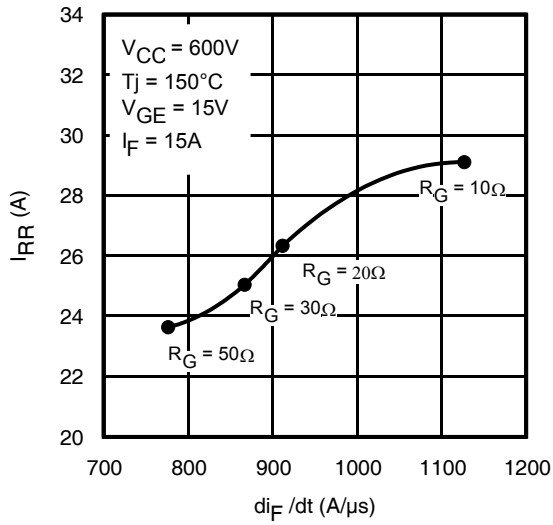
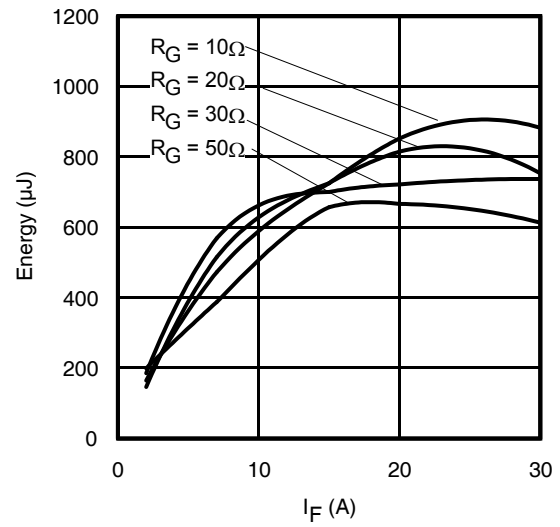
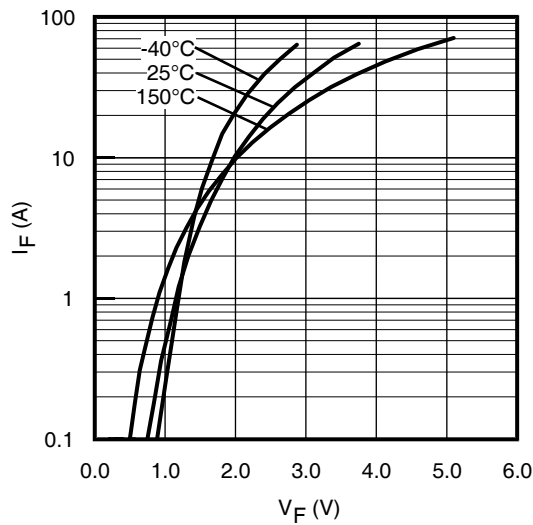
**Fig. 9 - Typ. Switching Time vs.  $I_C$**   
 $T_J = 150^\circ C$ ;  $V_{CE} = 600V$ ,  $R_G = 10\Omega$ ;  $V_{GE} = 15V$

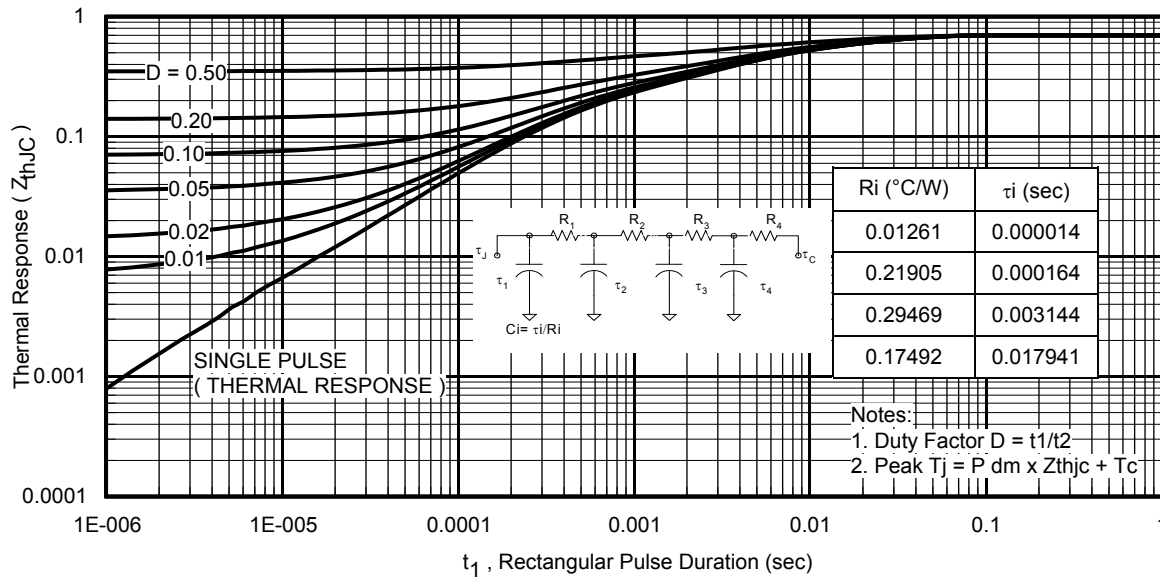
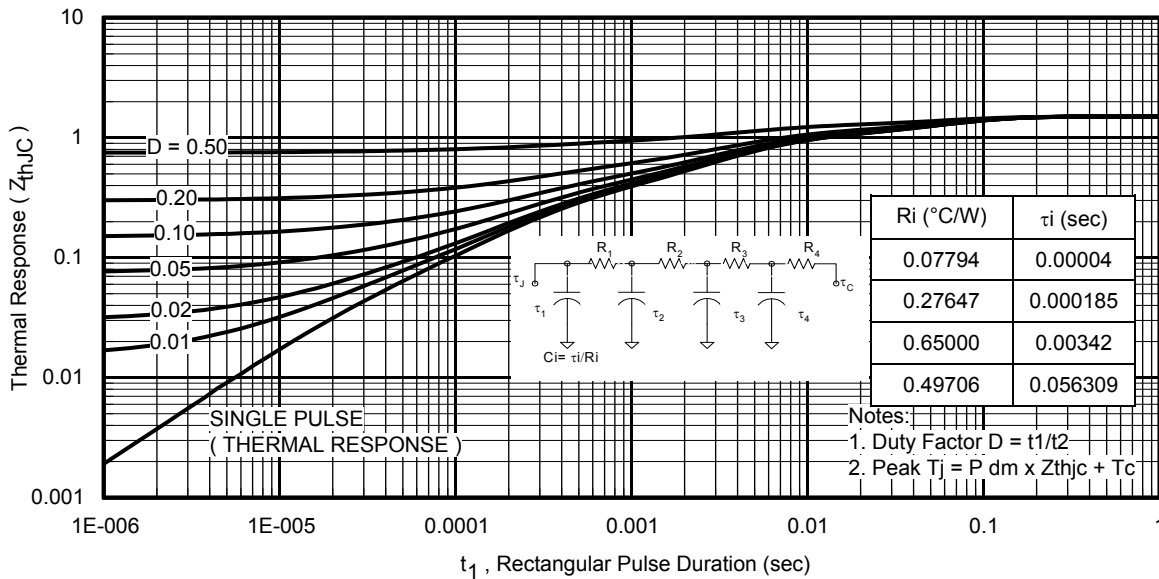


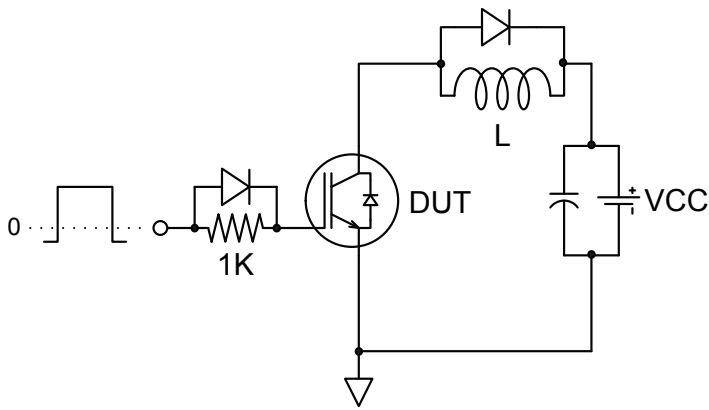
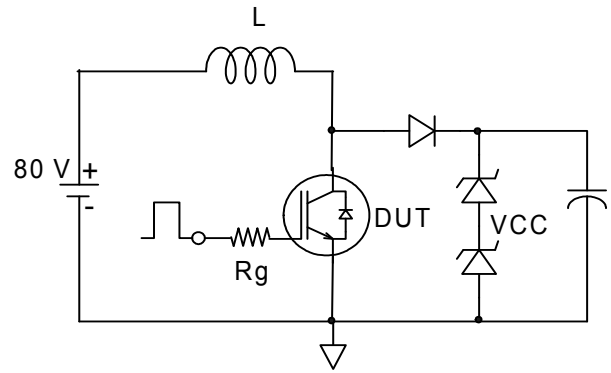
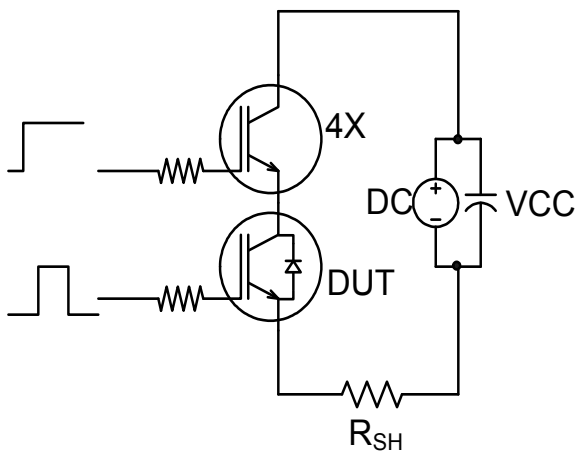
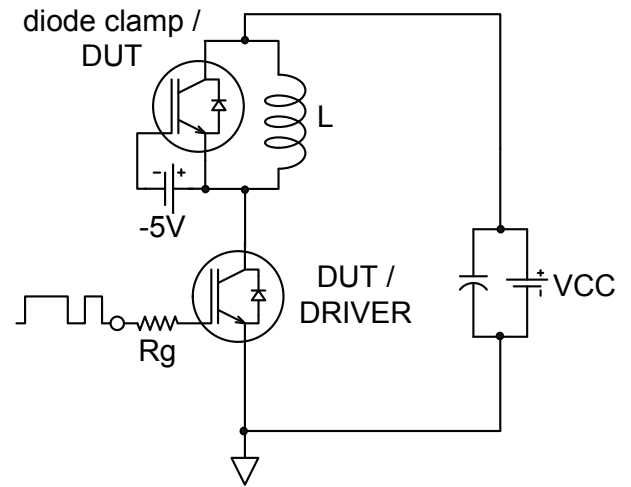
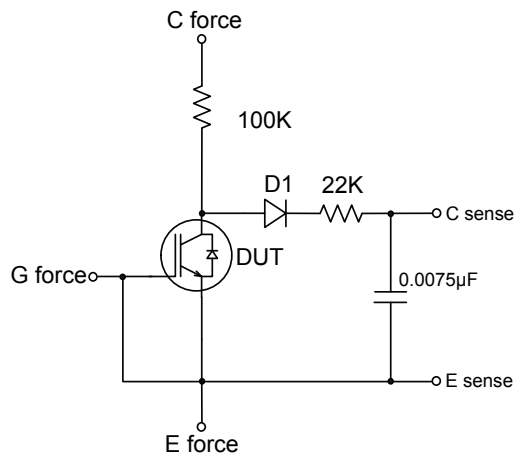
**Fig. 10 - Typ. Energy Loss vs.  $R_G$**   
 $V_{CE} = 600V$ ,  $I_{CE} = 15A$ ;  $V_{GE} = 15V$



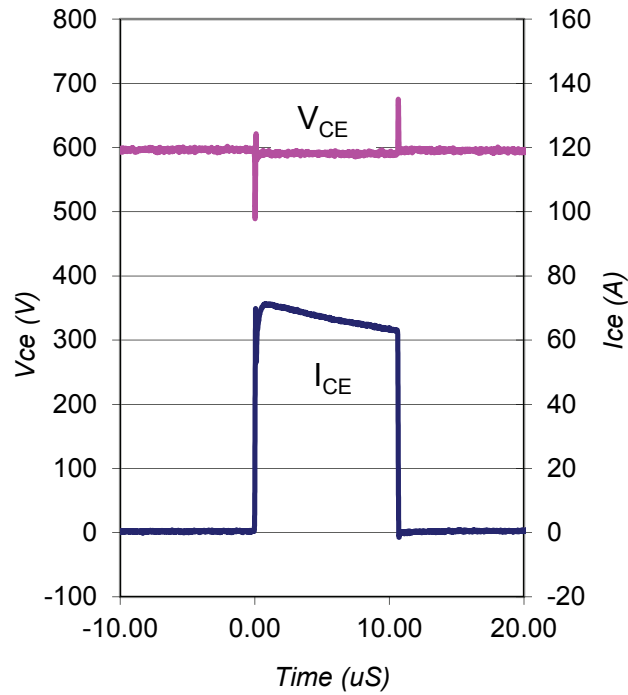
**Fig. 11 - Typ. Switching Time vs.  $R_G$**   
 $T_J = 150^\circ C$ ;  $V_{CE} = 600V$ ,  $I_{CE} = 15A$ ;  $V_{GE} = 15V$


**Fig. 12** - Typ.  $I_{RR}$  vs.  $di/dt$ 

**Fig. 13** - Typ. Diode  $E_{RR}$  vs.  $I_F$   
 $T_J = 150^\circ C$ 

**Fig. 14** - Typ. Diode Forward Voltage Drop Characteristics


**Fig. 15 - Maximum Transient Thermal Impedance, Junction-to-Case (IGBT)**

**Fig. 16 - Maximum Transient Thermal Impedance, Junction-to-Case (DIODE)**


**Fig.C.T.1 - Gate Charge Circuit (turn-off)**

**Fig.C.T.2 - RBSOA Circuit**

**Fig.C.T.3 - S.C. SOA Circuit**

**Fig.C.T.4 - Switching Loss Circuit  
(Board Stray Inductance 180nH)**

**Fig.C.T.5 - BVCES Filter Circuit**

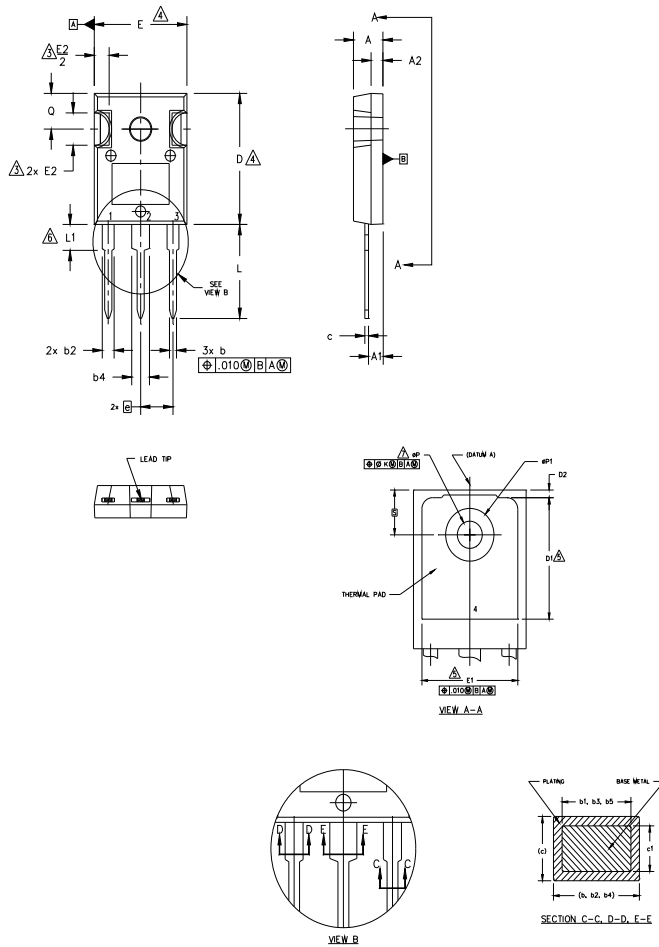




**Fig. WF1** - Typ. S.C. Waveform  
 @  $T_J = 150^\circ\text{C}$  using Fig. CT.3

## TO-247AC Package Outline

Dimensions are shown in millimeters (inches)



**NOTES:**

1. DIMENSIONING AND TOLERANCING AS PER ASME Y14.5M 1994.
2. DIMENSIONS ARE SHOWN IN INCHES.
3. CONTOUR OF SLOT OPTIONAL.
4. DIMENSION D & E DO NOT INCLUDE MOLD FLASH. MOLD FLASH SHALL NOT EXCEED .005" (0.127) PER SIDE. THESE DIMENSIONS ARE MEASURED AT THE OUTERMOST EXTREMES OF THE PLASTIC BODY.
5. THERMAL PAD CONTOUR OPTIONAL WITHIN DIMENSIONS D1 & E1.
6. LEAD FINISH UNCONTROLLED IN L1.
7. ØP TO HAVE A MAXIMUM DRAFT ANGLE OF 1.5 ° TO THE TOP OF THE PART WITH A MAXIMUM HOLE DIAMETER OF .154 INCH.
8. OUTLINE CONFORMS TO JEDEC OUTLINE TO-247AC .

SYMBOL	DIMENSIONS				NOTES
	INCHES		MILLIMETERS		
	MIN.	MAX.	MIN.	MAX.	
A	.183	.209	4.65	5.31	
A1	.087	.102	2.21	2.59	
A2	.059	.098	1.50	2.49	
b	.039	.055	0.99	1.40	
b1	.039	.053	0.99	1.35	
b2	.065	.094	1.65	2.39	
b3	.065	.092	1.65	2.34	
b4	.102	.135	2.59	3.43	
b5	.102	.133	2.59	3.38	
c	.015	.035	0.38	0.89	
c1	.015	.033	0.38	0.84	
D	.776	.815	19.71	20.70	4
D1	.515	-	13.08	-	5
D2	.020	.053	0.51	1.35	
E	.602	.625	15.29	15.87	4
E1	.530	-	13.46	-	
E2	.178	.216	4.52	5.49	
e	.215 BSC		5.46 BSC		
Øk	.010		0.25		
L	.559	.634	14.20	16.10	
L1	.146	.169	3.71	4.29	
ØP	.140	.144	3.56	3.66	
ØP1	-	.291	-	7.39	
Q	.209	.224	5.31	5.69	
S	.217 BSC		5.51 BSC		

**LEAD ASSIGNMENTS**

**HEXFET**

- 1.- GATE
- 2.- DRAIN
- 3.- SOURCE
- 4.- DRAIN

**IGBTs, CoPACK**

- 1.- GATE
- 2.- COLLECTOR
- 3.- EMITTER
- 4.- COLLECTOR

**DIODES**

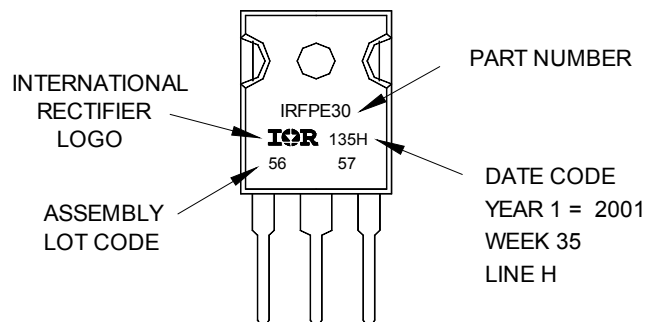
- 1.- ANODE/OPEN
- 2.- CATHODE
- 3.- ANODE

## TO-247AC Part Marking Information

Notes: This part marking information applies to devices produced after 02/26/2001

EXAMPLE: THIS IS AN IRFPE30  
WITH ASSEMBLY  
LOT CODE 5657  
ASSEMBLED ON WW 35, 2001  
IN THE ASSEMBLY LINE "H"

Note: "P" in assembly line position indicates "Lead-Free"

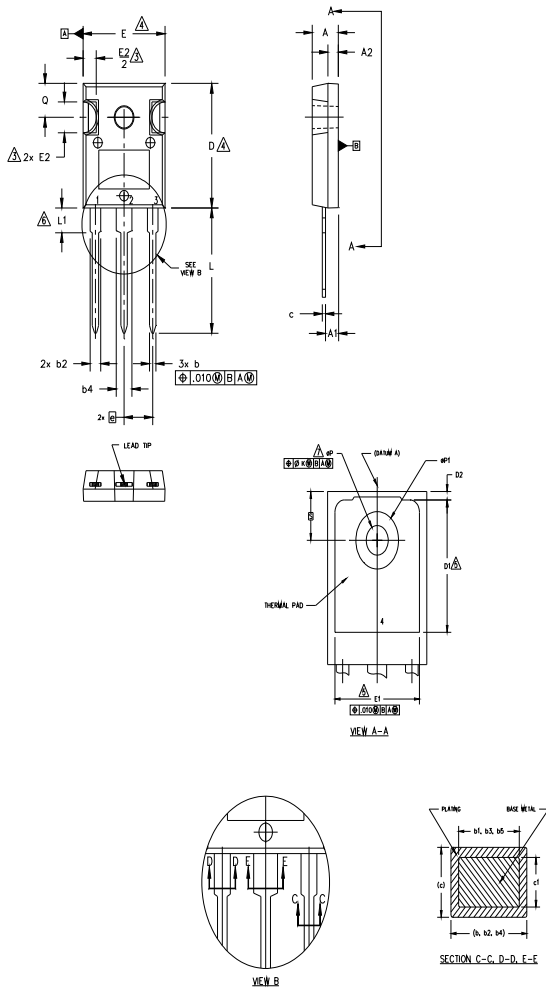


TO-247AC package is not recommended for Surface Mount Application.

Note: For the most current drawing please refer to IR website at <http://www.irf.com/package/>

## TO-247AD Package Outline

Dimensions are shown in millimeters (inches)



**NOTES:**

1. DIMENSIONING AND TOLERANCING AS PER ASME Y14.5M 1994.
2. DIMENSIONS ARE SHOWN IN INCHES.
3. CONTOUR OF SLOT OPTIONAL.
4. DIMENSION D & E DO NOT INCLUDE MOLD FLASH. MOLD FLASH SHALL NOT EXCEED .005" (0.127) PER SIDE. THESE DIMENSIONS ARE MEASURED AT THE OUTERMOST EXTREMES OF THE PLASTIC BODY.
5. THERMAL PAD CONTOUR OPTIONAL WITHIN DIMENSIONS D1 & E1.
6. LEAD FINISH UNCONTROLLED IN L1.
7.  $\phi P$  TO HAVE A MAXIMUM DRAFT ANGLE OF 1.5° TO THE TOP OF THE PART WITH A MAXIMUM HOLE DIAMETER OF .154 INCH.
8. OUTLINE CONFORMS TO JEDEC OUTLINE TO-247AD.

SYMBOL	DIMENSIONS				NOTES
	INCHES		MILLIMETERS		
	MIN.	MAX.	MIN.	MAX.	
A	.183	.209	4.65	5.31	
A1	.087	.102	2.21	2.59	
A2	.059	.098	1.50	2.49	
b	.039	.055	0.99	1.40	
b1	.039	.053	0.99	1.35	
b2	.065	.094	1.65	2.39	
b3	.065	.092	1.65	2.34	
b4	.102	.135	2.59	3.43	
b5	.102	.133	2.59	3.38	
c	.015	.035	0.38	0.89	
c1	.015	.033	0.38	0.84	
D	.776	.815	19.71	20.70	4
D1	.515	-	13.08	-	5
D2	.020	.053	0.51	1.35	
E	.602	.625	15.29	15.87	4
E1	.530	-	13.46	-	
E2	.178	.216	4.52	5.49	
e	.215 BSC		5.46 BSC		
$\phi k$	.010		0.25		
L	.780	.827	19.57	21.00	
L1	.146	.169	3.71	4.29	
$\phi P1$	.140	.144	3.56	3.66	
Q	-	.291	-	7.39	
S	.217 BSC		5.51 BSC		

LEAD ASSIGNMENTS

HEXFET

- 1.- GATE
- 2.- DRAIN
- 3.- SOURCE
- 4.- DRAIN

IGBTs, CoPACK

- 1.- GATE
- 2.- COLLECTOR
- 3.- EMITTER
- 4.- COLLECTOR

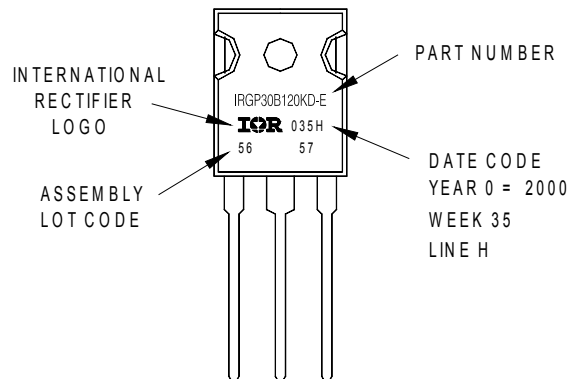
DIODES

- 1.- ANODE/OPEN
- 2.- CATHODE
- 3.- ANODE

## TO-247AD Part Marking Information

EXAMPLE: THIS IS AN IRGP30B120KD-E  
WITH ASSEMBLY  
LOT CODE 5657  
ASSEMBLED ON WW 35, 2000  
IN THE ASSEMBLY LINE "H"

Note: "P" in assembly line position  
indicates "Lead-Free"



TO-247AD package is not recommended for Surface Mount Application.

Note: For the most current drawing please refer to IR website at <http://www.irf.com/package/>

**Qualification Information<sup>†</sup>**

<b>Qualification Level</b>	Industrial <sup>†</sup> (per JEDEC JESD47F) <sup>††</sup>	
<b>Moisture Sensitivity Level</b>	TO-247AC	N/A
	TO-247AD	N/A
<b>RoHS Compliant</b>	Yes	

† Qualification standards can be found at International Rectifier’s web site: <http://www.irf.com/product-info/reliability/>

†† Applicable version of JEDEC standard at the time of product release.