



Chipsmall Limited consists of a professional team with an average of over 10 year of expertise in the distribution of electronic components. Based in Hongkong, we have already established firm and mutual-benefit business relationships with customers from,Europe,America and south Asia,supplying obsolete and hard-to-find components to meet their specific needs.

With the principle of "Quality Parts,Customers Priority,Honest Operation,and Considerate Service",our business mainly focus on the distribution of electronic components. Line cards we deal with include Microchip,ALPS,ROHM,Xilinx,Pulse,ON,Everlight and Freescale. Main products comprise IC,Modules,Potentiometer,IC Socket,Relay,Connector.Our parts cover such applications as commercial,industrial, and automotives areas.

We are looking forward to setting up business relationship with you and hope to provide you with the best service and solution. Let us make a better world for our industry!



## Contact us

Tel: +86-755-8981 8866 Fax: +86-755-8427 6832

Email & Skype: info@chipsmall.com Web: www.chipsmall.com

Address: A1208, Overseas Decoration Building, #122 Zhenhua RD., Futian, Shenzhen, China



**Insulated Gate Bipolar Transistor with Ultrafast Soft Recovery Diode**

$V_{CES} = 600V$   
 $I_C = 30A, T_C = 100^\circ C$   
 $t_{SC} \geq 5\mu s, T_{J(max)} = 175^\circ C$   
 $V_{CE(ON)} \text{ typ.} = 1.65V @ I_C = 18A$

**Applications**

- Industrial Motor Drive
- Inverters
- UPS
- Welding

IRGB4630DPbF TO-220AB      IRGP4630DPbF TO-247AC      IRGP4630D-EPbF TO-247AD

n-channel

IRGIB4630DPbF TO-220AB Full-Pak      IRGS4630DPbF D²Pak

G	C	E
Gate	Collector	Emitter

Features	Benefits
Low $V_{CE(ON)}$ and switching losses	High efficiency in a wide range of applications and switching frequencies
Square RBSOA and maximum junction temperature $175^\circ C$	Improved reliability due to rugged hard switching performance and high power capability
Positive $V_{CE(ON)}$ temperature coefficient and tight distribution of parameters	Excellent current sharing in parallel operation
$5\mu s$ Short Circuit SOA	Enables short circuit protection scheme
Lead-Free, RoHS Compliant	Environmentally friendly

Base part number	Package Type	Standard Pack		Orderable Part Number
		Form	Quantity	
IRGB4630DPbF	TO-220AB	Tube	50	IRGB4630DPbF
IRGIB4630DPbF	TO-220AB Full-Pak	Tube	50	IRGIB4630DPbF
IRGP4630DPbF	TO-247AC	Tube	25	IRGP4630DPbF
IRGP4630D-EPbF	TO-247AD	Tube	25	IRGP4630D-EPbF
IRGS4630DPbF	D²Pak	Tube	50	IRGS4630DPbF
		Tape and Reel Right	800	IRGS4630DTRRPbF
		Tape and Reel Left	800	IRGS4630DTRLpbF



**Absolute Maximum Ratings**

	Parameter	Max.	Units
$V_{CES}$	Collector-to-Emitter Voltage	600	V
$I_C @ T_C = 25^\circ\text{C}$	Continuous Collector Current①	47	A
$I_C @ T_C = 100^\circ\text{C}$	Continuous Collector Current①	30	
$I_{CM}$	Pulse Collector Current, $V_{GE}=15\text{V}$ ④	54	
$I_{LM}$	Clamped Inductive Load Current, $V_{GE}=20\text{V}$ ⑦	72	
$I_F @ T_C = 25^\circ\text{C}$	Diode Continuous Forward Current①	30	
$I_F @ T_C = 100^\circ\text{C}$	Diode Continuous Forward Current①	18	
$I_{FM}$	Diode Maximum Forward Current ④	72	
$V_{GE}$	Continuous Gate-to-Emitter Voltage	$\pm 20$	V
	Transient Gate to Emitter Voltage	$\pm 30$	
$P_D @ T_C = 25^\circ\text{C}$	Maximum Power Dissipation	206	W
$P_D @ T_C = 100^\circ\text{C}$	Maximum Power Dissipation	103	
$T_J$	Operating Junction and Storage Temperature Range	-40 to +175	C
$T_{STG}$			
	Soldering Temperature, for 10 sec. (1.6mm from case)	300	
	Mounting Torque, 6-32 or M3 Screw (TO-220, TO-247)	10 lbf-in (1.1 N·m)	

**Thermal Resistance**

	Parameter	Min.	Typ.	Max.	Units
$R_{\theta JC}$ (IGBT)②	Thermal Resistance Junction-to-Case (D <sup>2</sup> Pak, TO-220)	—	—	0.73	°C/W
	Thermal Resistance Junction-to-Case (TO-220 Full-Pak)	—	—	3.4	
	Thermal Resistance Junction-to-Case (TO-247)	—	—	0.78	
$R_{\theta JC}$ (Diode)②	Thermal Resistance Junction-to-Case (D <sup>2</sup> Pak, TO-220)	—	—	2.0	
	Thermal Resistance Junction-to-Case (TO-220 Full-Pak)	—	—	4.6	
	Thermal Resistance Junction-to-Case (TO-247)	—	—	2.1	
$R_{\theta CS}$	Thermal Resistance, Case-to-Sink (flat, greased surface-TO-220, D <sup>2</sup> Pak, TO-220 Full-Pak )	—	0.5	—	
	Thermal Resistance Case-to-Sink (TO-247)	—	0.24	—	
$R_{\theta JA}$	Thermal Resistance, Junction-to-Ambient (PCB Mount - D <sup>2</sup> Pak) ⑥	—	—	40	
	Thermal Resistance, Junction-to-Ambient (Socket Mount –TO-220)	—	—	62	
	Thermal Resistance, Junction-to-Ambient (Socket Mount –TO-247)	—	—	40	
	Thermal Resistance, Junction-to-Ambient (Socket Mount –TO-220 Full-Pak)	—	—	65	

**Electrical Characteristics @  $T_J = 25^\circ\text{C}$  (unless otherwise specified)**

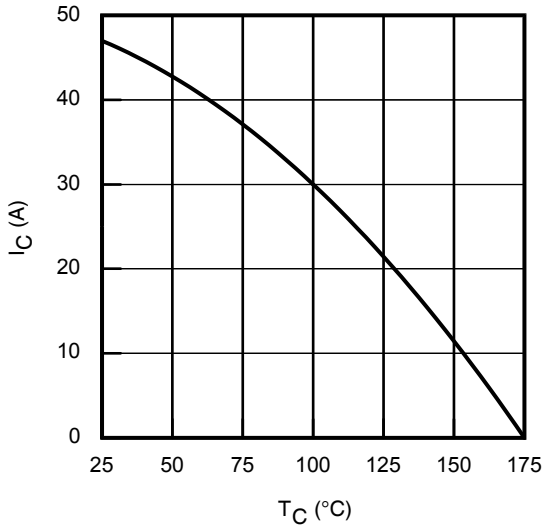
	Parameter	Min.	Typ.	Max.	Units	Conditions
$V_{(BR)CES}$	Collector-to-Emitter Breakdown Voltage	600	—	—	V	$V_{GE} = 0\text{V}$ , $I_C = 100\mu\text{A}$ ③
$\Delta V_{(BR)CES}/\Delta T_J$	Temperature Coeff. of Breakdown Voltage	—	0.40	—	V/°C	$V_{GE} = 0\text{V}$ , $I_C = 1\text{mA}$ (25°C-175°C)
$V_{CE(on)}$	Collector-to-Emitter Saturation Voltage	—	1.65	1.95	V	$I_C = 18\text{A}$ , $V_{GE} = 15\text{V}$ , $T_J = 25^\circ\text{C}$
		—	2.05	—		$I_C = 18\text{A}$ , $V_{GE} = 15\text{V}$ , $T_J = 150^\circ\text{C}$
		—	2.15	—		$I_C = 18\text{A}$ , $V_{GE} = 15\text{V}$ , $T_J = 175^\circ\text{C}$
$V_{GE(th)}$	Gate Threshold Voltage	4.0	—	6.5	V	$V_{CE} = V_{GE}$ , $I_C = 500\mu\text{A}$
$\Delta V_{GE(th)}/\Delta T_J$	Threshold Voltage Temp. Coefficient	—	-18	—	mV/°C	$V_{CE} = V_{GE}$ , $I_C = 1.0\text{mA}$ (25°C-175°C)
$g_{fe}$	Forward Transconductance	—	12	—	S	$V_{CE} = 50\text{V}$ , $I_C = 18\text{A}$ , $PW = 80\mu\text{s}$
$I_{CES}$	Collector-to-Emitter Leakage Current	—	2.0	25	$\mu\text{A}$	$V_{GE} = 0\text{V}$ , $V_{CE} = 600\text{V}$
		—	550	—		$V_{GE} = 0\text{V}$ , $V_{CE} = 600\text{V}$ , $T_J = 175^\circ\text{C}$
$I_{GES}$	Gate-to-Emitter Leakage Current	—	—	$\pm 100$	nA	$V_{GE} = \pm 20\text{V}$
$V_{FM}$	Diode Forward Voltage Drop	—	2.3	3.3	V	$I_F = 18\text{A}$
		—	1.6	—		$I_F = 18\text{A}$ , $T_J = 175^\circ\text{C}$

**Switching Characteristics @  $T_J = 25^\circ\text{C}$  (unless otherwise specified)**

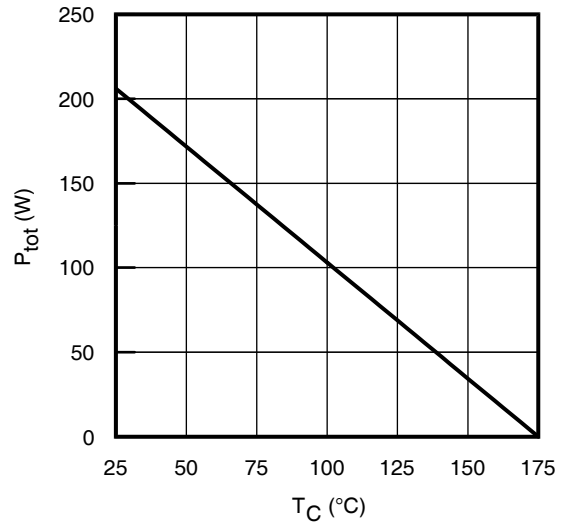
	Parameter	Min.	Typ.	Max	Units	Conditions
$Q_g$	Total Gate Charge	—	35	—	nC	$I_C = 18\text{A}$ $V_{GE} = 15\text{V}$ $V_{CC} = 400\text{V}$
$Q_{ge}$	Gate-to-Emitter Charge	—	10	—		
$Q_{gc}$	Gate-to-Collector Charge	—	15	—		
$E_{on}$	Turn-On Switching Loss	—	95	—	$\mu\text{J}$	$I_C = 18\text{A}$ , $V_{CC} = 400\text{V}$ , $V_{GE} = 15\text{V}$ $R_G = 22\Omega$ , $L = 200\mu\text{H}$ , $L_S = 150\text{nH}$ , $T_J = 25^\circ\text{C}$
$E_{off}$	Turn-Off Switching Loss	—	350	—		
$E_{total}$	Total Switching Loss	—	445	—		
$t_{d(on)}$	Turn-On delay time	—	40	—	ns	Energy losses include tail & diode reverse recovery ⑤
$t_r$	Rise time	—	25	—		
$t_{d(off)}$	Turn-Off delay time	—	105	—		
$t_f$	Fall time	—	25	—		
$t_{d(off)}$	Turn-Off delay time	—	105	—		
$E_{on}$	Turn-On Switching Loss	—	285	—	$\mu\text{J}$	$I_C = 18\text{A}$ , $V_{CC} = 400\text{V}$ , $V_{GE} = 15\text{V}$ $R_G = 22\Omega$ , $L = 200\mu\text{H}$ , $L_S = 150\text{nH}$ , $T_J = 175^\circ\text{C}$
$E_{off}$	Turn-Off Switching Loss	—	570	—		
$E_{total}$	Total Switching Loss	—	855	—		
$t_{d(on)}$	Turn-On delay time	—	40	—	ns	Energy losses include tail & diode reverse recovery ⑤
$t_r$	Rise time	—	25	—		
$t_{d(off)}$	Turn-Off delay time	—	120	—		
$t_f$	Fall time	—	40	—		
$t_{d(off)}$	Turn-Off delay time	—	120	—		
$C_{ies}$	Input Capacitance	—	1040	—	pF	$V_{GE} = 0\text{V}$ $V_{CC} = 30\text{V}$ $f = 1.0\text{MHz}$
$C_{oes}$	Output Capacitance	—	87	—		
$C_{res}$	Reverse Transfer Capacitance	—	32	—		
RBSOA	Reverse Bias Safe Operating Area	FULL SQUARE				$T_J = 175^\circ\text{C}$ , $I_C = 72\text{A}$ $V_{CC} = 480\text{V}$ , $V_p \leq 600\text{V}$ $R_G = 22\Omega$ , $V_{GE} = +20\text{V to } 0\text{V}$
SCSOA	Short Circuit Safe Operating Area	5.0	—	—	$\mu\text{s}$	$V_{CC} = 400\text{V}$ , $V_p \leq 600\text{V}$ $R_G = 22\Omega$ , $V_{GE} = +15\text{V to } 0\text{V}$
$E_{rec}$	Reverse Recovery Energy of the Diode	—	260	—	$\mu\text{J}$	$T_J = 175^\circ\text{C}$
$t_{rr}$	Diode Reverse Recovery Time	—	100	—	ns	$V_{CC} = 400\text{V}$ , $I_F = 18\text{A}$ , $V_{GE} = 15\text{V}$ , $R_g = 22\Omega$ , $L = 200\mu\text{H}$ , $L_S = 150\text{nH}$
$I_{rr}$	Peak Reverse Recovery Current	—	23	—	A	

**Notes:**

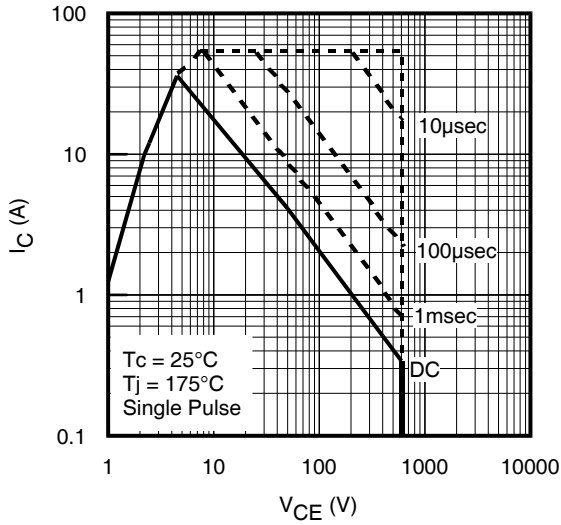
- ① Limited by maximum junction temperature. Not applicable for Full-Pak package: current value limited by  $R_{\theta JC}$ .
- ②  $R_{\theta}$  is measured at  $T_J$  of approximately  $90^\circ\text{C}$ .
- ③ Refer to AN-1086 for guidelines for measuring  $V_{(BR)CES}$  safely.
- ④ Pulse width limited by maximum junction temperature.
- ⑤ Values influenced by parasitic L and C in measurement.
- ⑥ When mounted on 1" square PCB (FR-4 or G-10 Material). For recommended footprint and soldering techniques refer to application note #AN-994, <http://www.irf.com/technical-info/appnotes/an-994.pdf>
- ⑦  $V_{CC} = 80\% (V_{CES})$ ,  $V_{GE} = 20\text{V}$ ,  $L = 100\mu\text{H}$ ,  $R_G = 22\Omega$ .



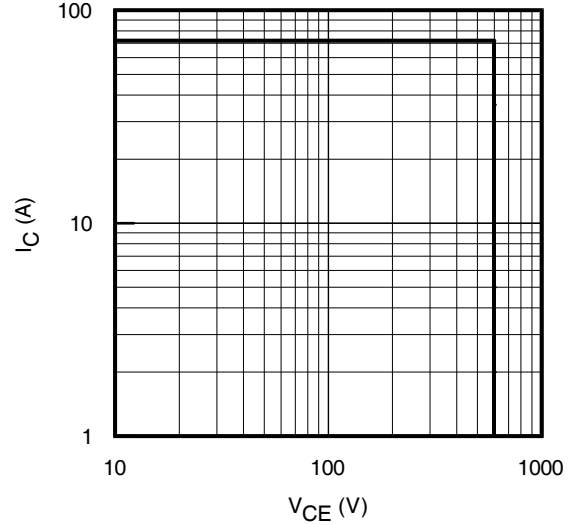
**Fig. 1** - Maximum DC Collector Current vs. Case Temperature



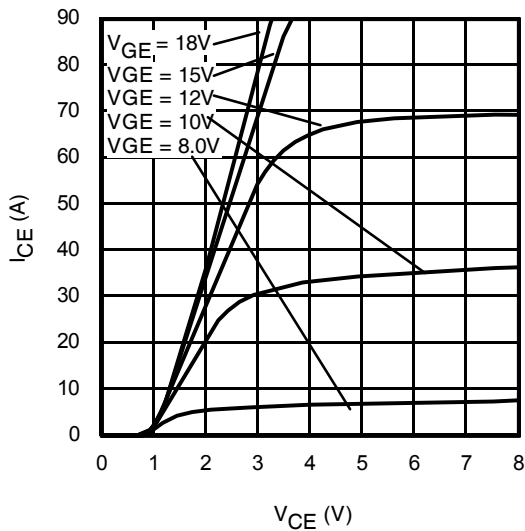
**Fig. 2** - Power Dissipation vs. Case Temperature



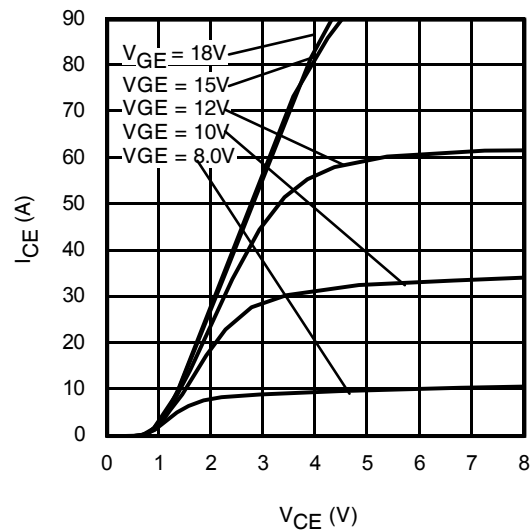
**Fig. 3** - Forward SOA  
 $T_C = 25^\circ\text{C}$ ;  $T_J \leq 175^\circ\text{C}$ ;  $V_{GE} = 15\text{V}$



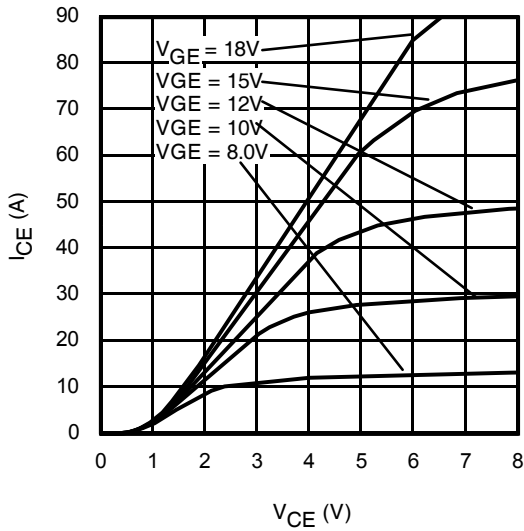
**Fig. 4** - Reverse Bias SOA  
 $T_J = 175^\circ\text{C}$ ;  $V_{GE} = 20\text{V}$



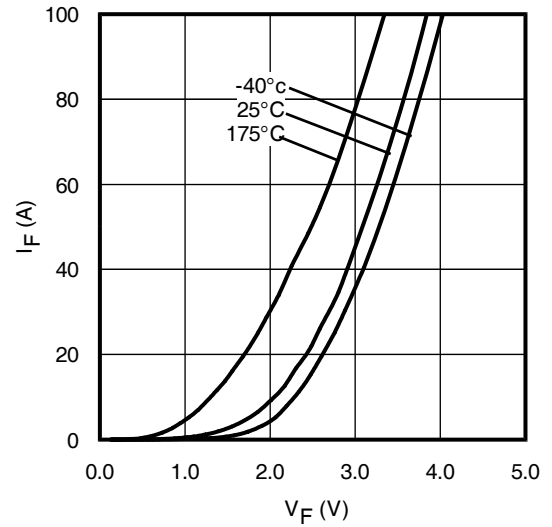
**Fig. 5** - Typ. IGBT Output Characteristics  
 $T_J = -40^\circ\text{C}$ ;  $t_p = 80\mu\text{s}$



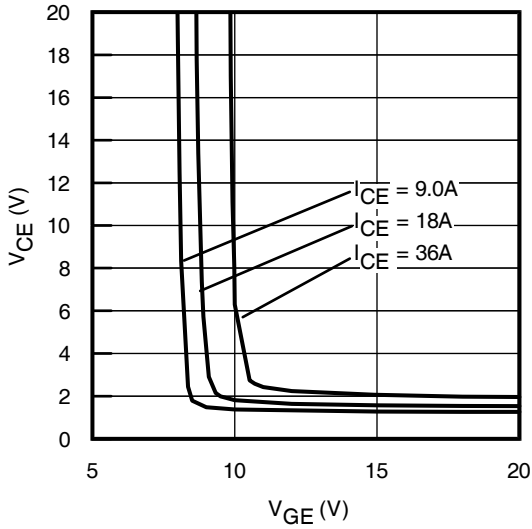
**Fig. 6** - Typ. IGBT Output Characteristics  
 $T_J = 25^\circ\text{C}$ ;  $t_p = 80\mu\text{s}$



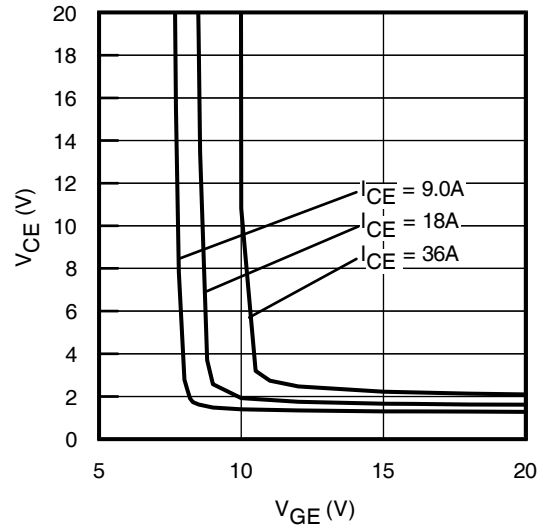
**Fig. 7 - Typ. IGBT Output Characteristics**  
 $T_J = 175^\circ\text{C}$ ;  $t_p = 80\mu\text{s}$



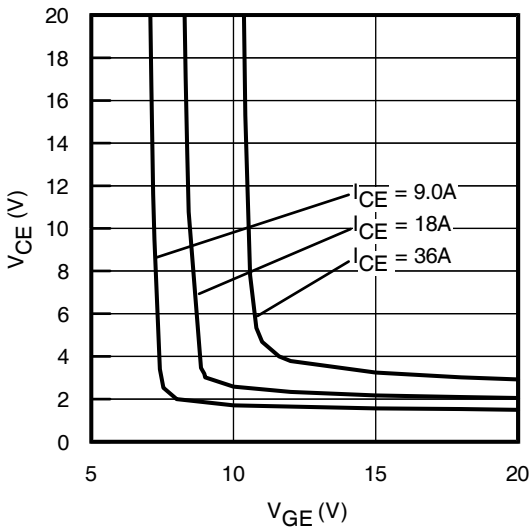
**Fig. 8 - Typ. Diode Forward Voltage Drop Characteristics**



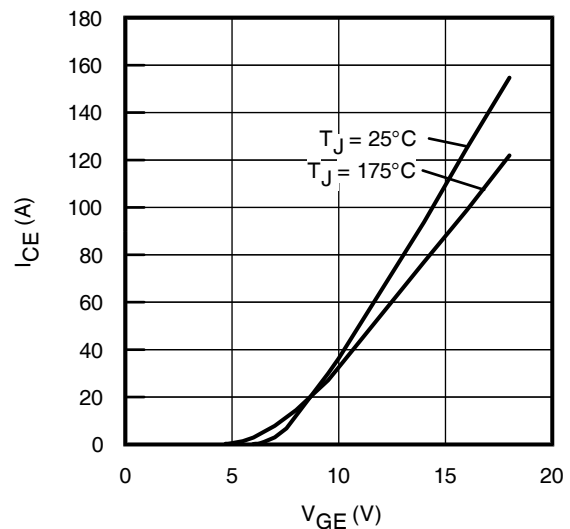
**Fig. 9 - Typical  $V_{CE}$  vs.  $V_{GE}$**   
 $T_J = -40^\circ\text{C}$



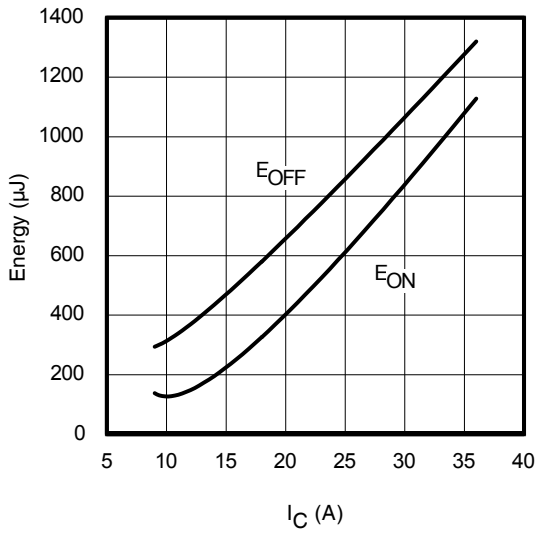
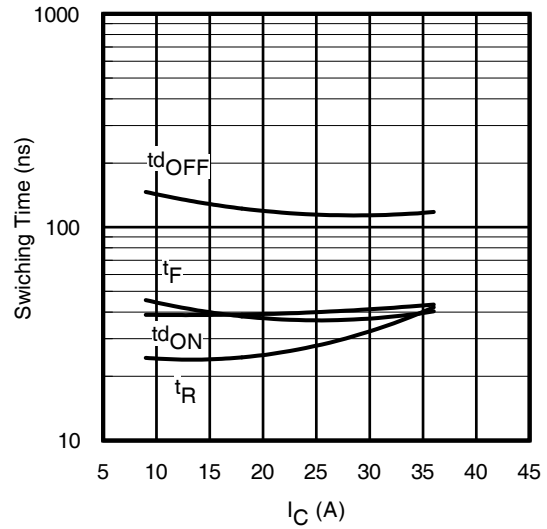
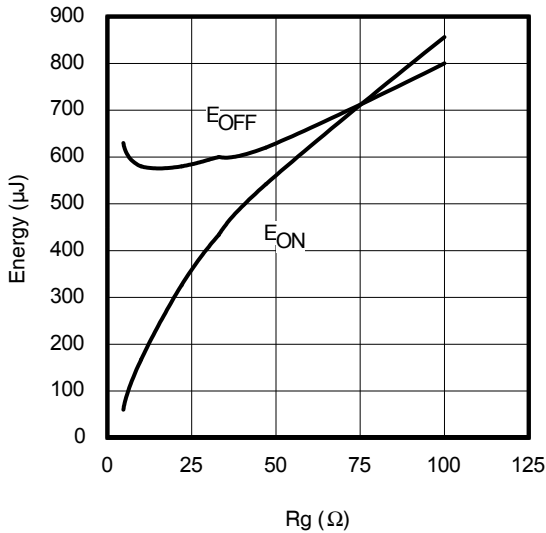
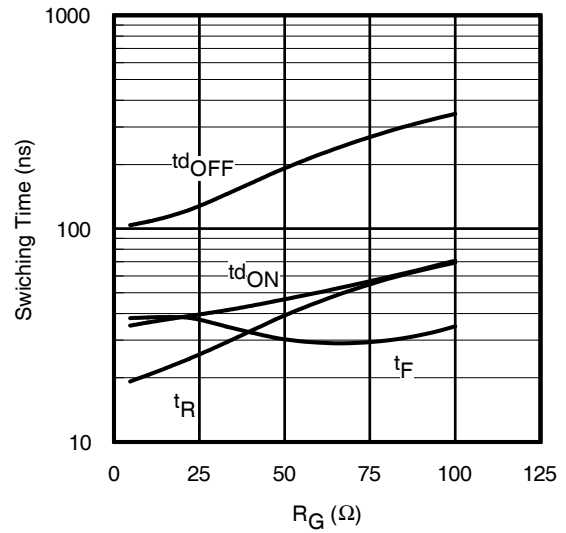
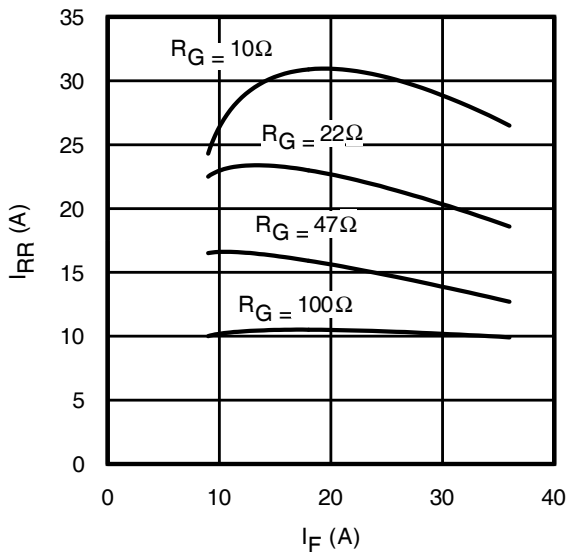
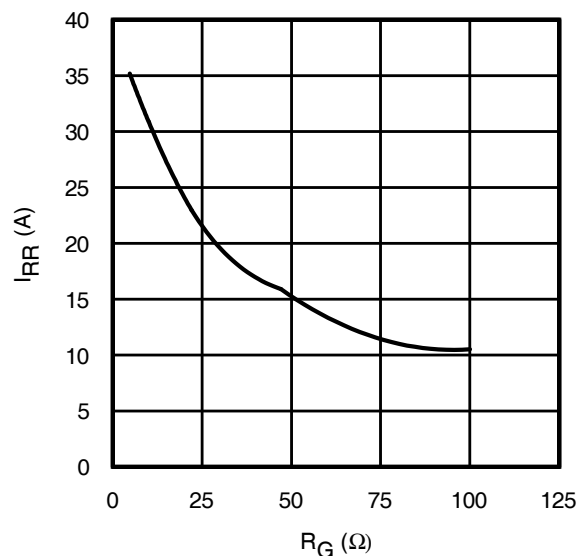
**Fig. 10 - Typical  $V_{CE}$  vs.  $V_{GE}$**   
 $T_J = 25^\circ\text{C}$

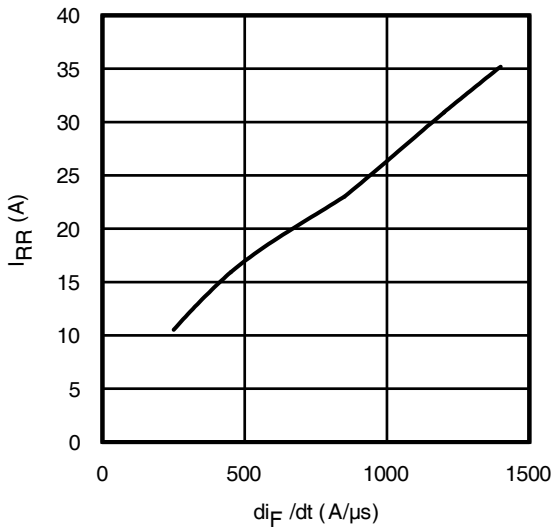


**Fig. 11 - Typical  $V_{CE}$  vs.  $V_{GE}$**   
 $T_J = 175^\circ\text{C}$

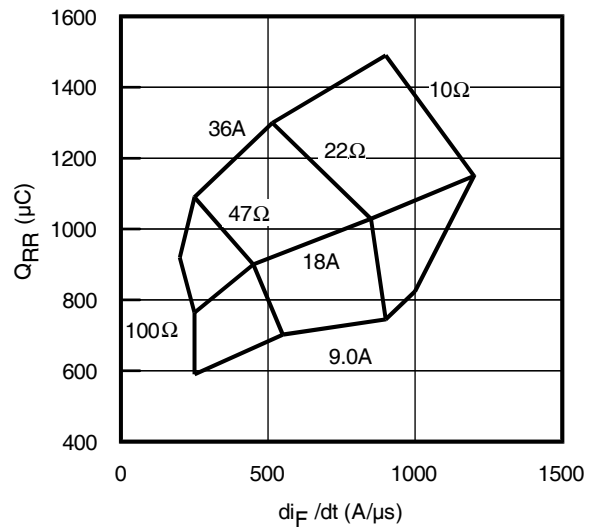


**Fig. 12 - Typ. Transfer Characteristics**  
 $V_{CE} = 50\text{V}$ ;  $t_p = 10\mu\text{s}$

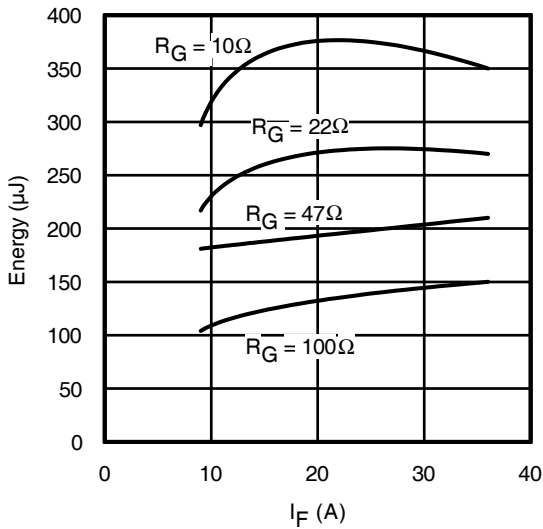

**Fig. 14 - Typ. Energy Loss vs.  $I_C$** 
 $T_J = 175^\circ C$ ;  $L = 200\mu H$ ;  $V_{CE} = 400V$ ;  $R_G = 22\Omega$ ;  $V_{GE} = 15V$ 

**Fig. 15 - Typ. Switching Time vs.  $I_C$** 
 $T_J = 175^\circ C$ ;  $L = 200\mu H$ ;  $V_{CE} = 400V$ ;  $R_G = 22\Omega$ ;  $V_{GE} = 15V$ 

**Fig. 16 - Typ. Energy Loss vs.  $R_G$** 
 $T_J = 175^\circ C$ ;  $L = 200\mu H$ ;  $V_{CE} = 400V$ ;  $I_{CE} = 18A$ ;  $V_{GE} = 15V$ 

**Fig. 17 - Typ. Switching Time vs.  $R_G$** 
 $T_J = 175^\circ C$ ;  $L = 200\mu H$ ;  $V_{CE} = 400V$ ;  $I_{CE} = 18A$ ;  $V_{GE} = 15V$ 

**Fig. 18 - Typ. Diode  $I_{RR}$  vs.  $I_F$** 
 $T_J = 175^\circ C$ 

**Fig. 19 - Typ. Diode  $I_{RR}$  vs.  $R_G$** 
 $T_J = 175^\circ C$



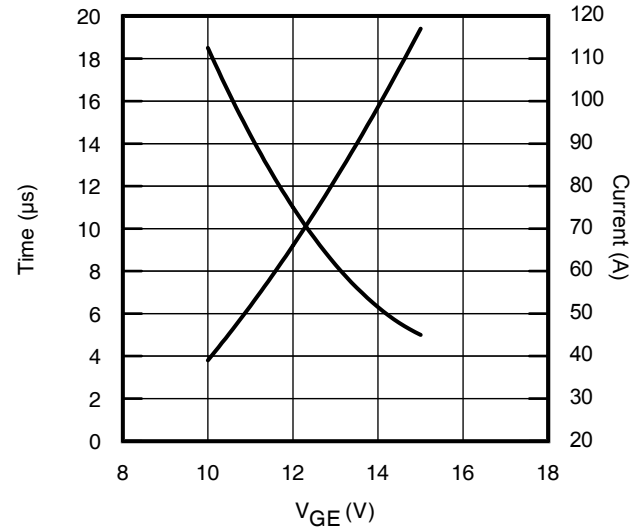
**Fig. 20** - Typ. Diode  $I_{RR}$  vs.  $di_F/dt$   
 $V_{CC} = 400V$ ;  $V_{GE} = 15V$ ;  $I_F = 18A$ ;  $T_J = 175^\circ C$



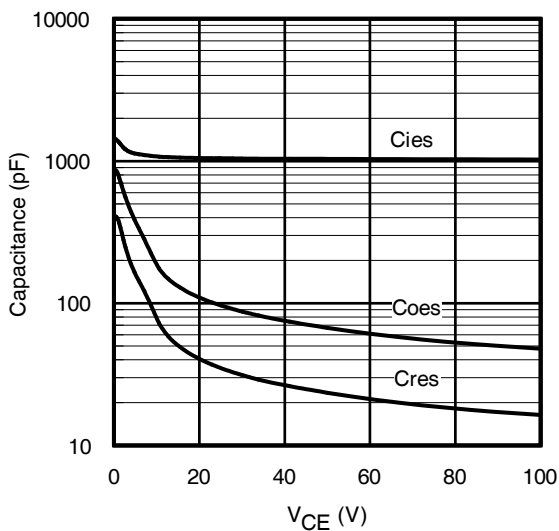
**Fig. 21** - Typ. Diode  $Q_{RR}$  vs.  $di_F/dt$   
 $V_{CC} = 400V$ ;  $V_{GE} = 15V$ ;  $T_J = 175^\circ C$



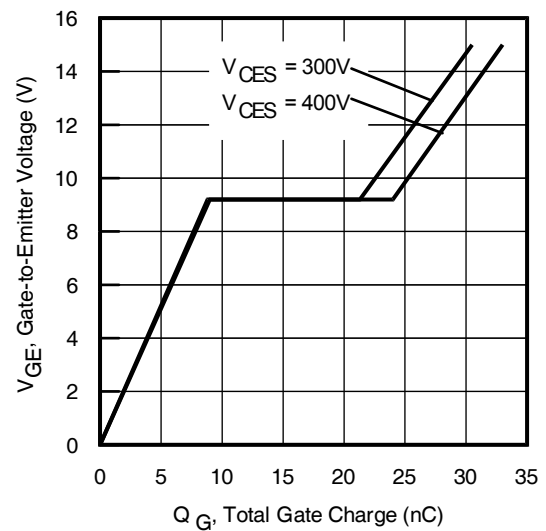
**Fig. 22** - Typ. Diode  $E_{RR}$  vs.  $I_F$   
 $T_J = 175^\circ C$



**Fig. 23** -  $V_{GE}$  vs. Short Circuit Time  
 $V_{CC} = 400V$ ;  $T_C = 25^\circ C$

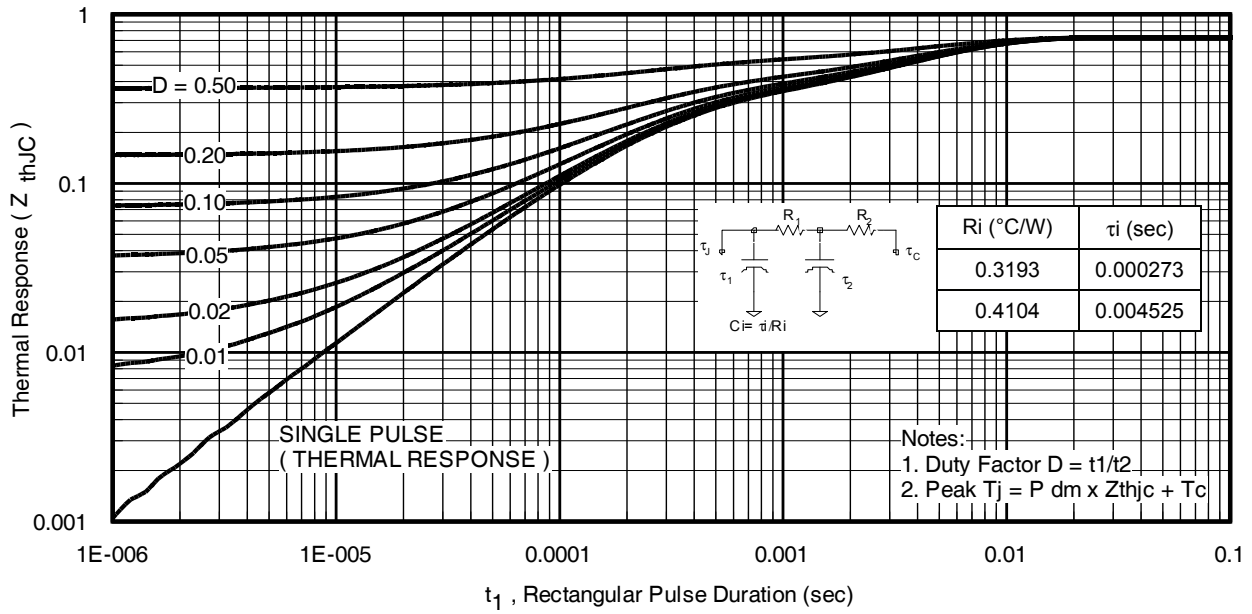
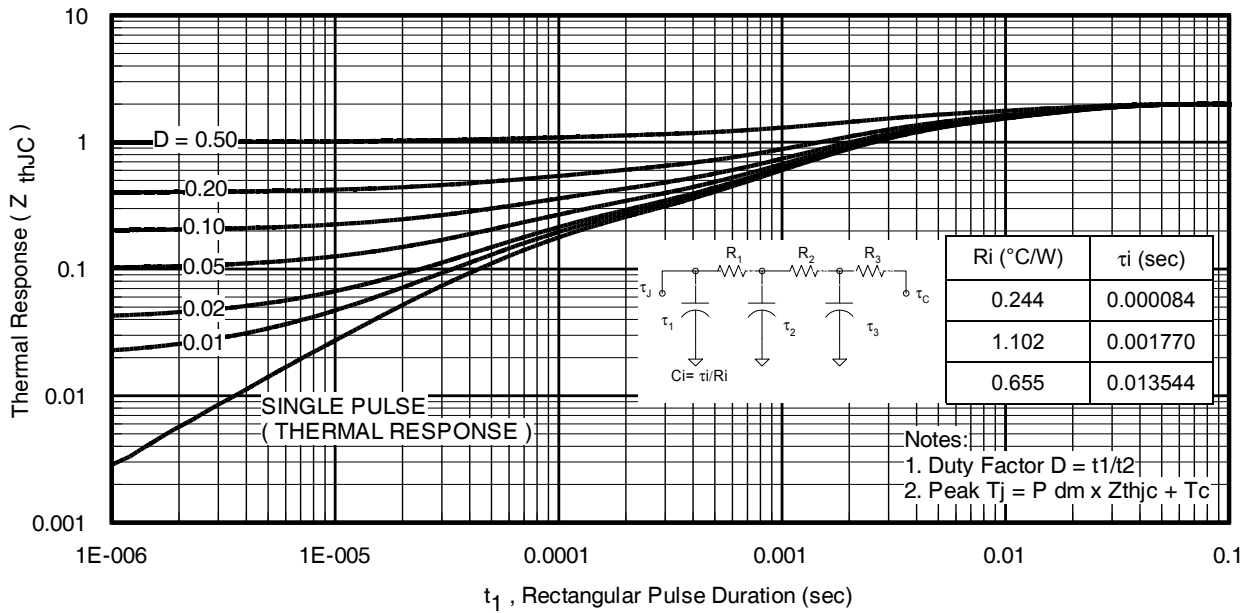


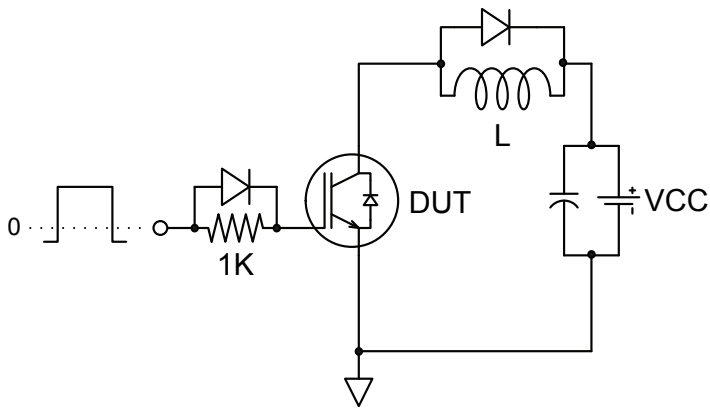
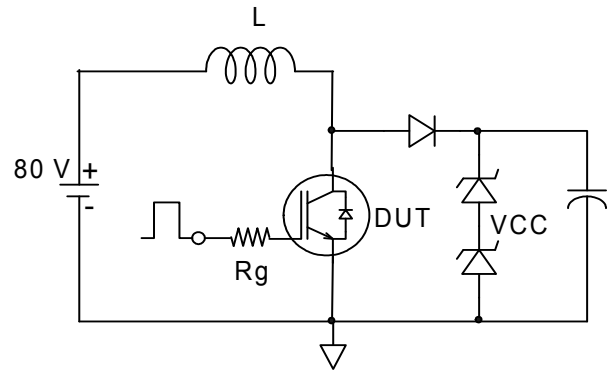
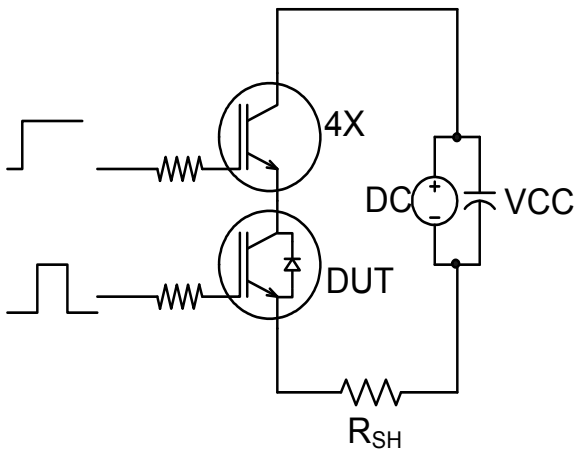
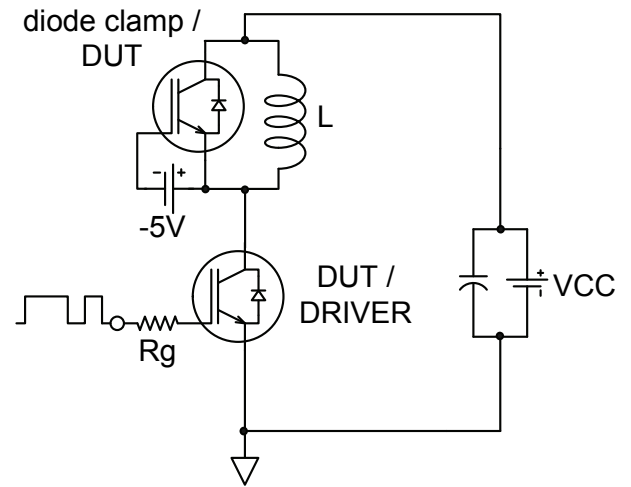
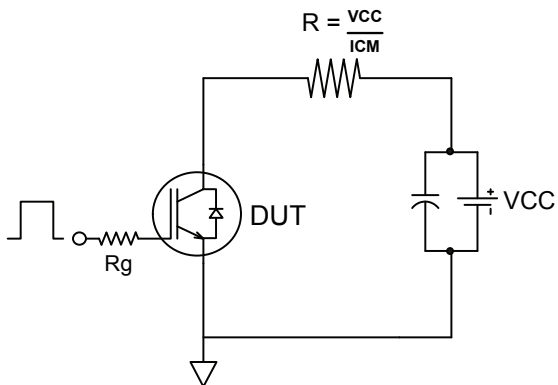
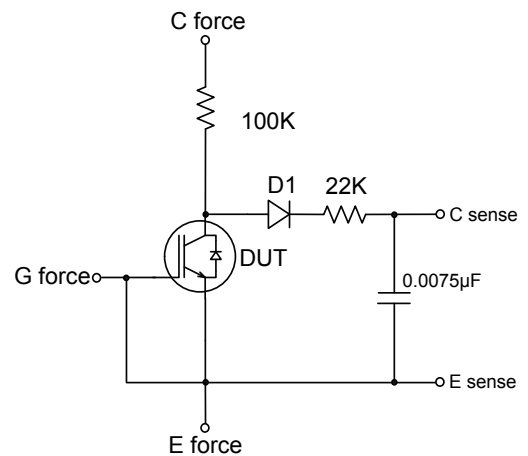
**Fig. 24** - Typ. Capacitance vs.  $V_{CE}$   
 $V_{GE} = 0V$ ;  $f = 1MHz$

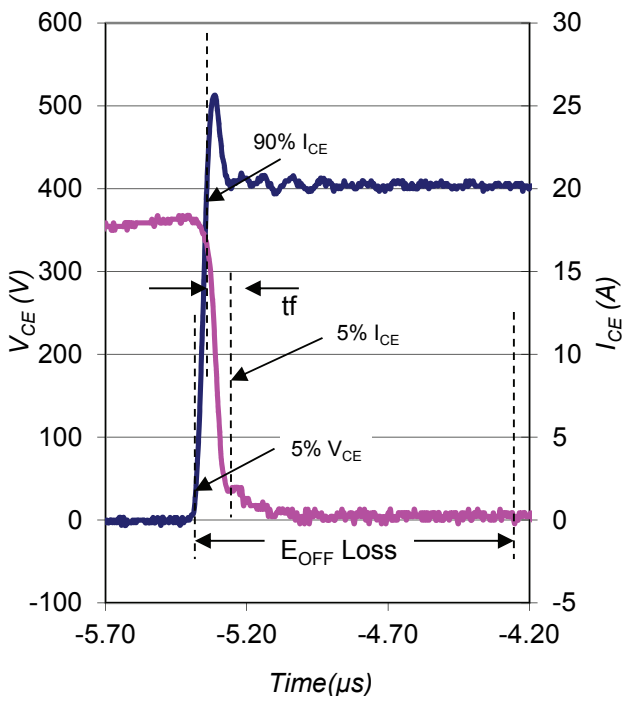


**Fig. 25** - Typical Gate Charge vs.  $V_{GE}$   
 $I_{CE} = 18A$ ;  $L = 600\mu H$

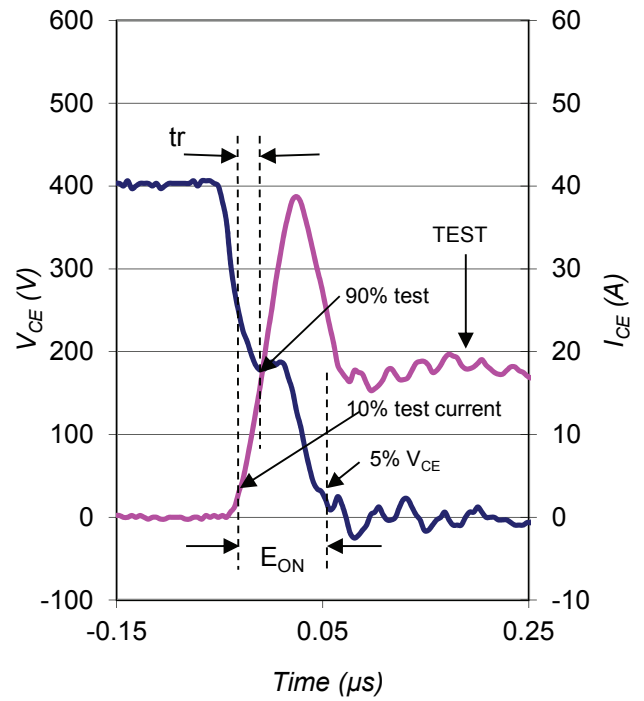



**Fig. 26 - Maximum Transient Thermal Impedance, Junction-to-Case (IGBT-TO-220Pak)**

**Fig. 27 - Maximum Transient Thermal Impedance, Junction-to-Case (DIODE- TO-220Pak)**

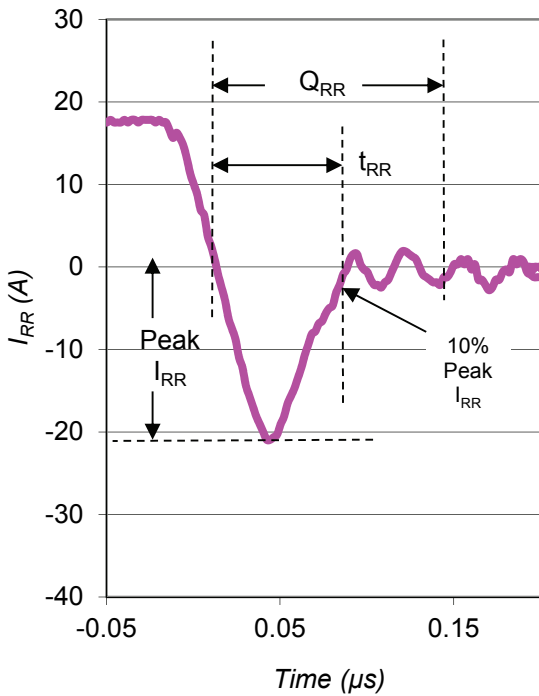

**Fig.C.T.1 - Gate Charge Circuit (turn-off)**

**Fig.C.T.2 - RBSOA Circuit**

**Fig.C.T.3 - S.C. SOA Circuit**

**Fig.C.T.4 - Switching Loss Circuit**

**Fig.C.T.5 - Resistive Load Circuit**

**Fig.C.T.6 - BVCES Filter Circuit**



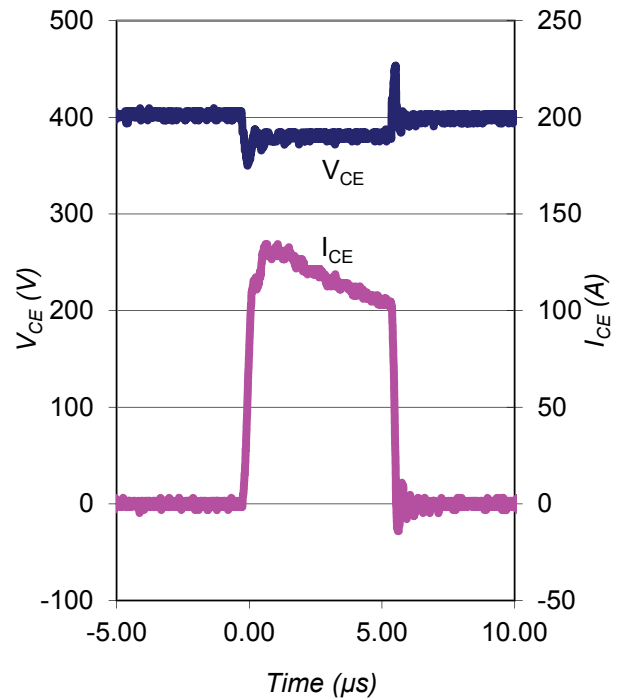
**Fig. WF1** - Typ. Turn-off Loss Waveform  
@  $T_J = 175^\circ C$  using Fig. CT.4



**Fig. WF2** - Typ. Turn-on Loss Waveform  
@  $T_J = 175^\circ C$  using Fig. CT.4



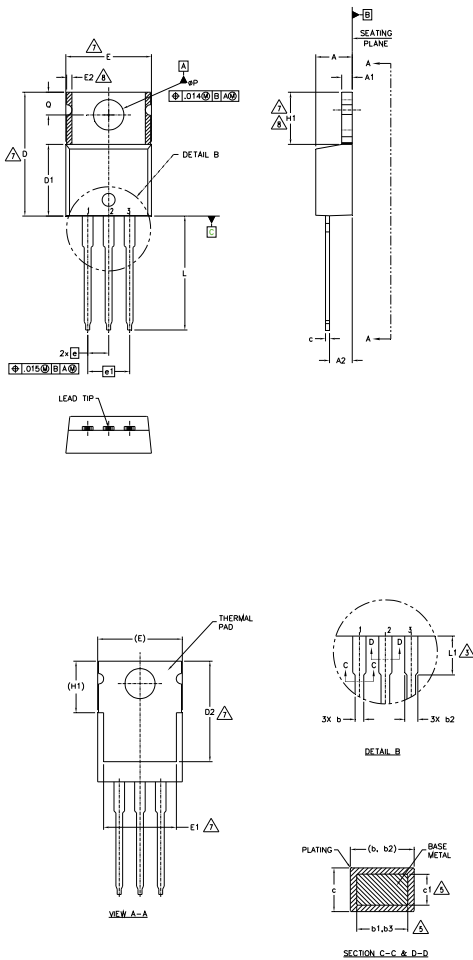
**Fig. WF3** - Typ. Diode Recovery Waveform  
@  $T_J = 175^\circ C$  using Fig. CT.4



**Fig. WF4** - Typ. S.C. Waveform  
@  $T_J = 150^\circ C$  using Fig. CT.3

# TO-220AB Package Outline

(Dimensions are shown in millimeters (inches))



**NOTES:**

- 1.- DIMENSIONING AND TOLERANCING AS PER ASME Y14.5 M- 1994.
- 2.- DIMENSIONS ARE SHOWN IN INCHES [MILLIMETERS].
- 3.- LEAD DIMENSION AND FINISH UNCONTROLLED IN L1.
- 4.- DIMENSION D, D1 & E DO NOT INCLUDE MOLD FLASH. MOLD FLASH SHALL NOT EXCEED .005" (0.127) PER SIDE. THESE DIMENSIONS ARE MEASURED AT THE OUTERMOST EXTREMES OF THE PLASTIC BODY.
- 5.- DIMENSION b1, b3 & c1 APPLY TO BASE METAL ONLY.
- 6.- CONTROLLING DIMENSION : INCHES.
- 7.- THERMAL PAD CONTOUR OPTIONAL WITHIN DIMENSIONS E,H1,D2 & E1
- 8.- DIMENSION E2 X H1 DEFINE A ZONE WHERE STAMPING AND SINGULATION IRREGULARITIES ARE ALLOWED.
- 9.- OUTLINE CONFORMS TO JEDEC TO-220, EXCEPT A2 (max.) AND D2 (min.) WHERE DIMENSIONS ARE DERIVED FROM THE ACTUAL PACKAGE OUTLINE.

SYMBOL	DIMENSIONS				NOTES
	MILLIMETERS		INCHES		
	MIN.	MAX.	MIN.	MAX.	
A	3.56	4.83	.140	.190	
A1	1.14	1.40	.045	.055	
A2	2.03	2.92	.080	.115	
b	0.38	1.01	.015	.040	
b1	0.38	0.97	.015	.038	5
b2	1.14	1.78	.045	.070	
b3	1.14	1.73	.045	.068	5
c	0.36	0.61	.014	.024	
c1	0.36	0.56	.014	.022	5
D	14.22	16.51	.560	.650	4
D1	8.38	9.02	.330	.355	
D2	11.68	12.88	.460	.507	7
E	9.65	10.67	.380	.420	4,7
E1	6.86	8.89	.270	.350	7
E2	-	0.76	-	.030	8
e	2.54 BSC		.100 BSC		
e1	5.08 BSC		.200 BSC		
H1	5.84	6.86	.230	.270	7,8
L	12.70	14.73	.500	.580	
L1	3.56	4.06	.140	.160	3
ØP	3.54	4.08	.139	.161	
Q	2.54	3.42	.100	.135	

**LEAD ASSIGNMENTS**

**HEXFET**

- 1.- GATE
- 2.- DRAIN
- 3.- SOURCE

**IGBTs, CoPACK**

- 1.- GATE
- 2.- COLLECTOR
- 3.- EMITTER

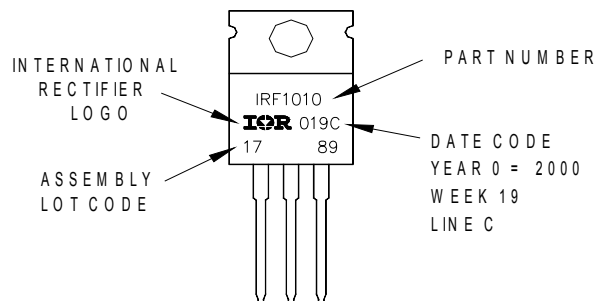
**DIODES**

- 1.- ANODE
- 2.- CATHODE
- 3.- ANODE

## TO-220AB Part Marking Information

EXAMPLE: THIS IS AN IRF1010  
 LOT CODE 1789  
 ASSEMBLED ON WW 19, 2000  
 IN THE ASSEMBLY LINE "C"

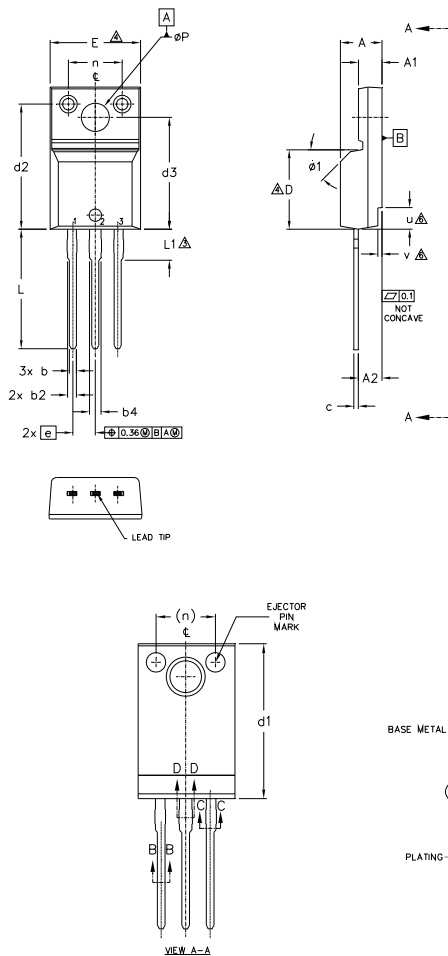
Note: "P" in assembly line position indicates "Lead - Free"



TO-220AB package is not recommended for Surface Mount Application.

# TO-220AB Full- Pak Package Outline

(Dimensions are shown in millimeters (inches))



- NOTES:
- 1.0 DIMENSIONING AND TOLERANCING AS PER ASME Y14.5 M- 1994.
  - 2.0 DIMENSIONS ARE SHOWN IN MILLIMETERS [INCHES].
  - 3.0 LEAD DIMENSION AND FINISH UNCONTROLLED IN L1.
  - 4.0 DIMENSION D & E DO NOT INCLUDE MOLD FLASH. MOLD FLASH SHALL NOT EXCEED .005" (0.127) PER SIDE. THESE DIMENSIONS ARE MEASURED AT THE OUTER MOST EXTREMES OF THE PLASTIC BODY.
  - 5.0 DIMENSION b1, b3, b5 & c1 APPLY TO BASE METAL ONLY.
  - 6.0 STEP OPTIONAL ON PLASTIC BODY DEFINED BY DIMENSIONS u & v.
  - 7.0 CONTROLLING DIMENSION : INCHES.

**LEAD ASSIGNMENTS**

- HEXFEEET
- 1.- GATE
  - 2.- DRAIN
  - 3.- SOURCE

**IGBTs\_CoPACK**

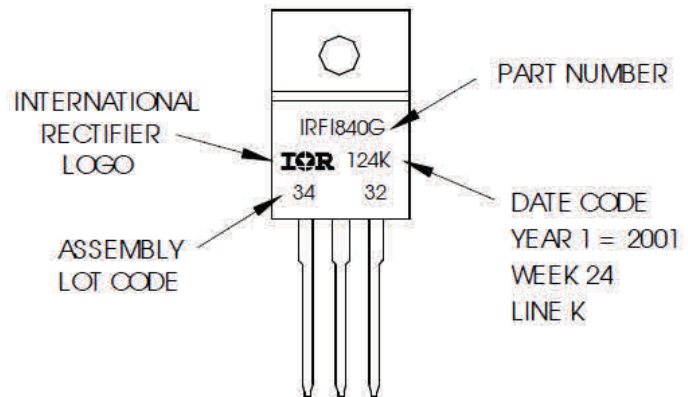
- 1.- GATE
- 2.- COLLECTOR
- 3.- EMITTER

SYMBOL	DIMENSIONS				NOTES
	MILLIMETERS		INCHES		
	MIN.	MAX.	MIN.	MAX.	
A	4.57	4.83	.180	.190	
A1	2.57	2.82	.101	.111	
A2	2.51	2.92	.099	.115	
b	0.61	0.94	.024	.037	
b1	0.61	0.89	.024	.035	5
b2	0.76	1.27	.030	.050	
b3	0.76	1.22	.030	.048	5
b4	1.02	1.52	.040	.060	
b5	1.02	1.47	.040	.058	5
c	0.33	0.63	.013	.025	
c1	0.33	0.58	.013	.023	5
D	8.66	9.80	.341	.386	4
d1	15.80	16.13	.622	.635	
d2	13.97	14.22	.550	.560	
d3	12.29	12.93	.484	.509	
E	9.63	10.74	.379	.423	4
e	2.54 BSC		.100 BSC		
L	13.21	13.72	.520	.540	
L1	3.10	3.68	.122	.145	3
n	6.05	6.60	.238	.260	
øP	3.05	3.45	.120	.136	
u	2.39	2.49	.094	.098	6
v	0.41	0.51	.016	.020	6
ø1	-	45°	-	45°	

## TO-220AB Full- Pak Part Marking Information

EXAMPLE: THIS IS AN IRF1840G  
 WITH ASSEMBLY  
 LOT CODE 3432  
 ASSEMBLED ON WW 24, 2001  
 IN THE ASSEMBLY LINE "K"

Note: "P" in assembly line position  
 indicates "Lead-Free"

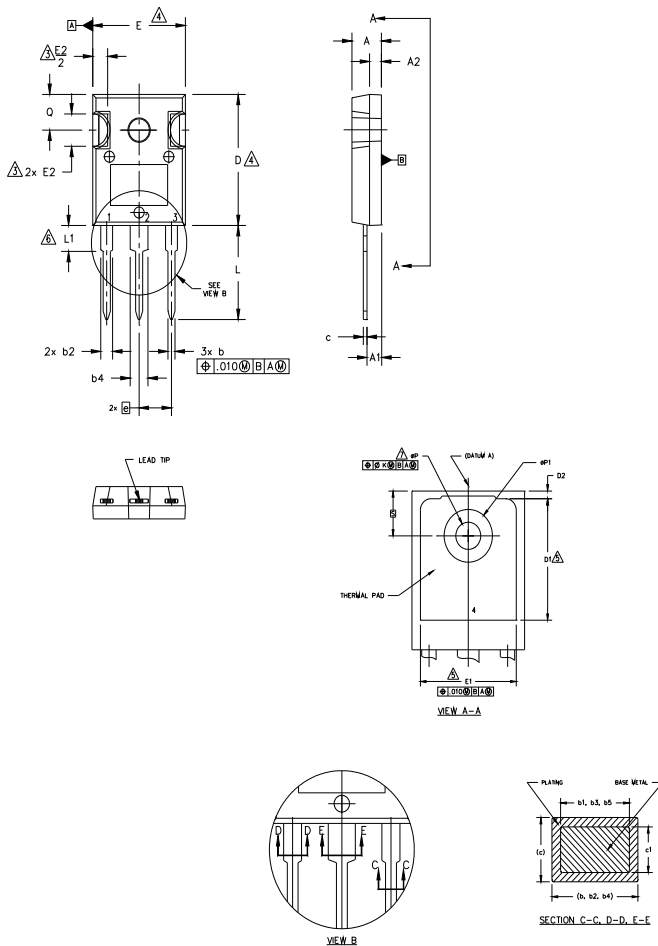


TO-220AB Full-Pak package is not recommended for Surface Mount Application.



# TO-247AC Package Outline

Dimensions are shown in millimeters (inches)



**NOTES:**

1. DIMENSIONING AND TOLERANCING AS PER ASME Y14.5M 1994.
2. DIMENSIONS ARE SHOWN IN INCHES.
3. CONTOUR OF SLOT OPTIONAL.
4. DIMENSION D & E DO NOT INCLUDE MOLD FLASH. MOLD FLASH SHALL NOT EXCEED .005" (0.127) PER SIDE. THESE DIMENSIONS ARE MEASURED AT THE OUTERMOST EXTREMES OF THE PLASTIC BODY.
5. THERMAL PAD CONTOUR OPTIONAL WITHIN DIMENSIONS D1 & E1.
6. LEAD FINISH UNCONTROLLED IN L1.
7.  $\phi P$  TO HAVE A MAXIMUM DRAFT ANGLE OF 1.5 ° TO THE TOP OF THE PART WITH A MAXIMUM HOLE DIAMETER OF .154 INCH.
8. OUTLINE CONFORMS TO JEDEC OUTLINE TO-247AC .

SYMBOL	DIMENSIONS				NOTES
	INCHES		MILLIMETERS		
	MIN.	MAX.	MIN.	MAX.	
A	.183	.209	4.65	5.31	
A1	.087	.102	2.21	2.59	
A2	.059	.098	1.50	2.49	
b	.039	.055	0.99	1.40	
b1	.039	.053	0.99	1.35	
b2	.065	.094	1.65	2.39	
b3	.065	.092	1.65	2.34	
b4	.102	.135	2.59	3.43	
b5	.102	.133	2.59	3.38	
c	.015	.035	0.38	0.89	
c1	.015	.033	0.38	0.84	
D	.776	.815	19.71	20.70	4
D1	.515	-	13.08	-	5
D2	.020	.053	0.51	1.35	
E	.602	.625	15.29	15.87	4
E1	.530	-	13.46	-	
E2	.178	.216	4.52	5.49	
e	.215 BSC		5.46 BSC		
$\phi k$	.010		0.25		
L	.559	.634	14.20	16.10	
L1	.146	.169	3.71	4.29	
$\phi P$	.140	.144	3.56	3.66	
$\phi P1$	-	.291	-	7.39	
Q	.209	.224	5.31	5.69	
S	.217 BSC		5.51 BSC		

**LEAD ASSIGNMENTS**

**HEXFET**

- 1.- GATE
- 2.- DRAIN
- 3.- SOURCE
- 4.- DRAIN

**IGBTs, CoPACK**

- 1.- GATE
- 2.- COLLECTOR
- 3.- EMITTER
- 4.- COLLECTOR

**DIODES**

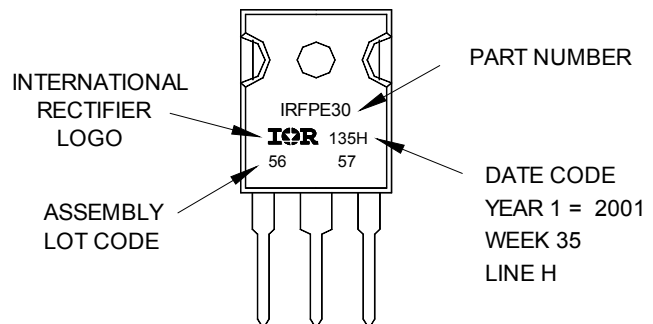
- 1.- ANODE/OPEN
- 2.- CATHODE
- 3.- ANODE

## TO-247AC Part Marking Information

Notes: This part marking information applies to devices produced after 02/26/2001

EXAMPLE: THIS IS AN IRFPE30  
WITH ASSEMBLY  
LOT CODE 5657  
ASSEMBLED ON WW 35, 2001  
IN THE ASSEMBLY LINE "H"

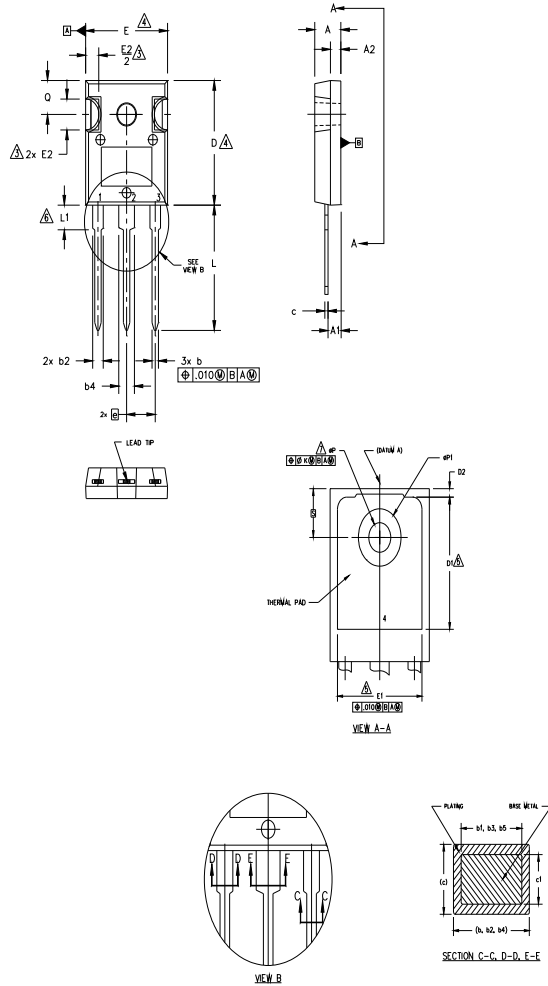
Note: "P" in assembly line position  
indicates "Lead-Free"



TO-247AC package is not recommended for Surface Mount Application.

## TO-247AD Package Outline

Dimensions are shown in millimeters (inches)


**NOTES:**

1. DIMENSIONING AND TOLERANCING AS PER ASME Y14.5M 1994.
2. DIMENSIONS ARE SHOWN IN INCHES.
3. CONTOUR OF SLOT OPTIONAL.
4. DIMENSION D & E DO NOT INCLUDE MOLD FLASH. MOLD FLASH SHALL NOT EXCEED .005" (0.127) PER SIDE. THESE DIMENSIONS ARE MEASURED AT THE OUTERMOST EXTREMES OF THE PLASTIC BODY.
5. THERMAL PAD CONTOUR OPTIONAL WITHIN DIMENSIONS D1 & E1.
6. LEAD FINISH UNCONTROLLED IN L1.
7.  $\phi P$  TO HAVE A MAXIMUM DRAFT ANGLE OF 1.5° TO THE TOP OF THE PART WITH A MAXIMUM HOLE DIAMETER OF .154 INCH.
8. OUTLINE CONFORMS TO JEDEC OUTLINE TO-247AD.

SYMBOL	DIMENSIONS				NOTES
	INCHES		MILLIMETERS		
	MIN.	MAX.	MIN.	MAX.	
A	.183	.209	4.65	5.31	
A1	.087	.102	2.21	2.59	
A2	.059	.098	1.50	2.49	
b	.039	.055	0.99	1.40	
b1	.039	.053	0.99	1.35	
b2	.065	.094	1.65	2.39	
b3	.065	.092	1.65	2.34	
b4	.102	.135	2.59	3.43	
b5	.102	.133	2.59	3.38	
c	.015	.035	0.38	0.89	
c1	.015	.033	0.38	0.84	
D	.776	.815	19.71	20.70	4
D1	.515	-	13.08	-	5
D2	.020	.053	0.51	1.35	
E	.602	.625	15.29	15.87	4
E1	.530	-	13.46	-	
E2	.178	.216	4.52	5.49	
e	.215 BSC		5.46 BSC		
	.010		0.25		
L	.780	.827	19.57	21.00	
L1	.146	.169	3.71	4.29	
$\phi P$	.140	.144	3.56	3.66	
$\phi P1$	-	.291	-	7.39	
Q	.209	.224	5.31	5.69	
S	.217 BSC		5.51 BSC		

**LEAD ASSIGNMENTS**
**HEXFET**

- 1.- GATE
- 2.- DRAIN
- 3.- SOURCE
- 4.- DRAIN

**IGBTs, CoPACK**

- 1.- GATE
- 2.- COLLECTOR
- 3.- EMITTER
- 4.- COLLECTOR

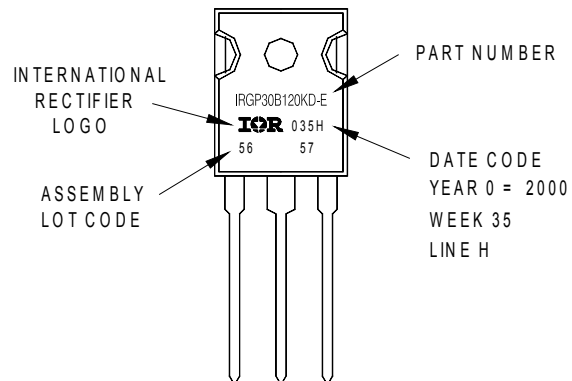
**DIODES**

- 1.- ANODE/OPEN
- 2.- CATHODE
- 3.- ANODE

## TO-247AD Part Marking Information

EXAMPLE: THIS IS AN IRGP30B120KD-E  
WITH ASSEMBLY  
LOT CODE 5657  
ASSEMBLED ON WW 35, 2000  
IN THE ASSEMBLY LINE "H"

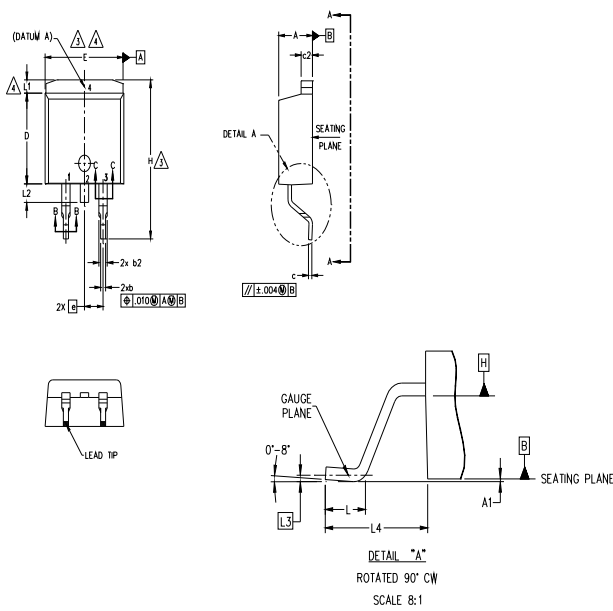
Note: "P" in assembly line position  
indicates "Lead-Free"



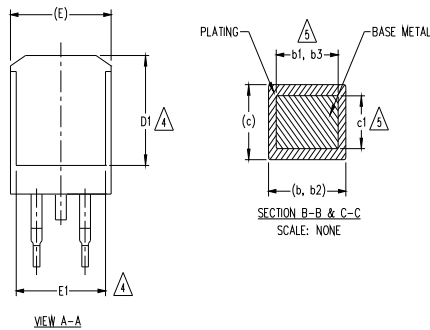
TO-247AD package is not recommended for Surface Mount Application.

## D<sup>2</sup>-PAK (TO-263AB) Package Outline

Dimensions are shown in millimeters (inches)



SYMBOL	DIMENSIONS				NOTES
	MILLIMETERS		INCHES		
	MIN.	MAX.	MIN.	MAX.	
A	4.06	4.83	.160	.190	5
A1	0.00	0.254	.000	.010	
b	0.51	0.99	.020	.039	5
b1	0.51	0.89	.020	.035	
b2	1.14	1.78	.045	.070	5
b3	1.14	1.73	.045	.068	
c	0.38	0.74	.015	.029	5
c1	0.38	0.58	.015	.023	
c2	1.14	1.65	.045	.065	3
D	8.38	9.65	.330	.380	
D1	6.86	—	.270	—	4
E	9.65	10.67	.380	.420	3,4
E1	6.22	—	.245	—	4
e	2.54 BSC		.100 BSC		4
H	14.61	15.88	.575	.625	
L	1.78	2.79	.070	.110	4
L1	—	1.65	—	.066	
L2	—	1.78	—	.070	4
L3	0.25 BSC		.010 BSC		
L4	4.78	5.28	.188	.208	



### LEAD ASSIGNMENTS

#### DIODES

- 1.- ANODE (TWO DIE) / OPEN (ONE DIE)
2. 4.- CATHODE
- 3.- ANODE

#### HEXFET

- 1.- GATE
2. 4.- DRAIN
- 3.- SOURCE

#### IGBTs, CoPACK

- 1.- GATE
2. 4.- COLLECTOR
- 3.- EMITTER

### NOTES:

1. DIMENSIONING AND TOLERANCING PER ASME Y14.5M-1994

2. DIMENSIONS ARE SHOWN IN MILLIMETERS [INCHES]

3. DIMENSION D & E DO NOT INCLUDE MOLD FLASH. MOLD FLASH SHALL NOT EXCEED 0.127 [0.005"] PER SIDE. THESE DIMENSIONS ARE MEASURED AT THE OUTMOST EXTREMES OF THE PLASTIC BODY AT DATUM H.

4. THERMAL PAD CONTOUR OPTIONAL WITHIN DIMENSION E, L1, D1 & E1.

5. DIMENSION b1 AND c1 APPLY TO BASE METAL ONLY.

6. DATUM A & B TO BE DETERMINED AT DATUM PLANE H.

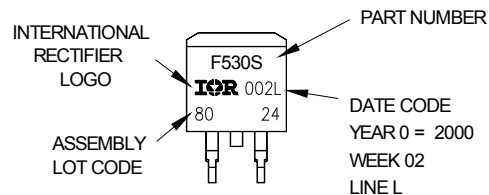
7. CONTROLLING DIMENSION: INCH.

8. OUTLINE CONFORMS TO JEDEC OUTLINE TO-263AB.

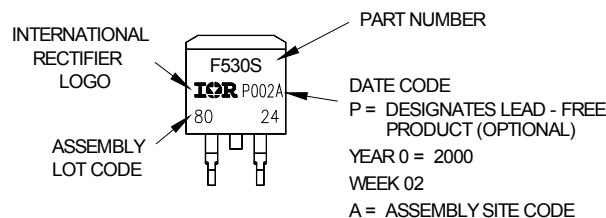
## D<sup>2</sup>-Pak (TO-263AB) Part Marking Information

EXAMPLE: THIS IS AN IRF530S WITH  
LOT CODE 8024  
ASSEMBLED ON WW 02, 2000  
IN THE ASSEMBLY LINE "L"

Note: "P" in assembly line position  
indicates "Lead - Free"

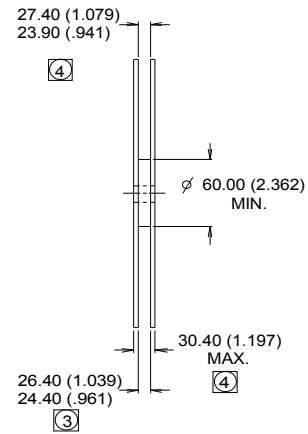
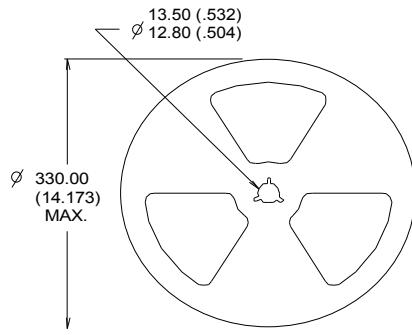
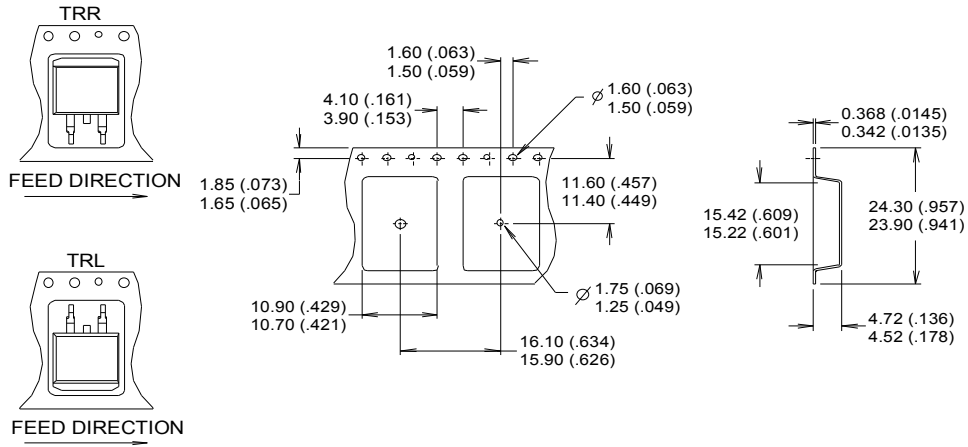


OR



# D<sup>2</sup>Pak Tape & Reel Information

(Dimensions are shown in millimeters (inches))



- NOTES :
1. CONFORMS TO EIA-418.
  2. CONTROLLING DIMENSION: MILLIMETER.
  3. DIMENSION MEASURED @ HUB.
  4. INCLUDES FLANGE DISTORTION @ OUTER EDGE.

**Qualification Information†**

<b>Qualification Level</b>	Industrial (per JEDEC JESD47F) ††	
<b>Moisture Sensitivity Level</b>	TO-220AB	N/A
	TO-220AB-Full-Pak	
	TO-247AC	
	TO-247AD	
	D <sup>2</sup> Pak	MSL1
<b>RoHS Compliant</b>	Yes	

† Qualification standards can be found at International Rectifier's web site: <http://www.irf.com/product-info/reliability/>

†† Applicable version of JEDEC standard at the time of product release.

**Published by**  
**Infineon Technologies AG**  
**81726 München, Germany**  
 © Infineon Technologies AG 2015  
 All Rights Reserved.

**IMPORTANT NOTICE**

The information given in this document shall in no event be regarded as a guarantee of conditions or characteristics ("Beschaffenheitsgarantie"). With respect to any examples, hints or any typical values stated herein and/or any information regarding the application of the product, Infineon Technologies hereby disclaims any and all warranties and liabilities of any kind, including without limitation warranties of non-infringement of intellectual property rights of any third party.

In addition, any information given in this document is subject to customer's compliance with its obligations stated in this document and any applicable legal requirements, norms and standards concerning customer's products and any use of the product of Infineon Technologies in customer's applications.

The data contained in this document is exclusively intended for technically trained staff. It is the responsibility of customer's technical departments to evaluate the suitability of the product for the intended application and the completeness of the product information given in this document with respect to such application.

For further information on the product, technology, delivery terms and conditions and prices please contact your nearest Infineon Technologies office ([www.infineon.com](http://www.infineon.com)).

**WARNINGS**

Due to technical requirements products may contain dangerous substances. For information on the types in question please contact your nearest Infineon Technologies office.

Except as otherwise explicitly approved by Infineon Technologies in a written document signed by authorized representatives of Infineon Technologies, Infineon Technologies' products may not be used in any applications where a failure of the product or any consequences of the use thereof can reasonably be expected to result in personal injury.