



Chipsmall Limited consists of a professional team with an average of over 10 year of expertise in the distribution of electronic components. Based in Hongkong, we have already established firm and mutual-benefit business relationships with customers from,Europe,America and south Asia,supplying obsolete and hard-to-find components to meet their specific needs.

With the principle of “Quality Parts,Customers Priority,Honest Operation,and Considerate Service”,our business mainly focus on the distribution of electronic components. Line cards we deal with include Microchip,ALPS,ROHM,Xilinx,Pulse,ON,Everlight and Freescale. Main products comprise IC,Modules,Potentiometer,IC Socket,Relay,Connector.Our parts cover such applications as commercial,industrial, and automotives areas.

We are looking forward to setting up business relationship with you and hope to provide you with the best service and solution. Let us make a better world for our industry!



## Contact us

Tel: +86-755-8981 8866 Fax: +86-755-8427 6832

Email & Skype: info@chipsmall.com Web: www.chipsmall.com

Address: A1208, Overseas Decoration Building, #122 Zhenhua RD., Futian, Shenzhen, China



**INSULATED GATE BIPOLAR TRANSISTOR WITH  
ULTRAFAST SOFT RECOVERY DIODE**

**Motor Control Co-Pack IGBT**

**Features**

- Low  $V_{CE(on)}$  Non Punch Through (NPT) Technology
- Low Diode  $V_F$  (1.76V Typical @ 25A & 25°C)
- 10  $\mu$ s Short Circuit Capability
- Square RBSOA
- Ultrasoft Diode Recovery Characteristics
- Positive  $V_{CE(on)}$  Temperature Coefficient
- Extended Lead TO-247AD Package
- Lead-Free

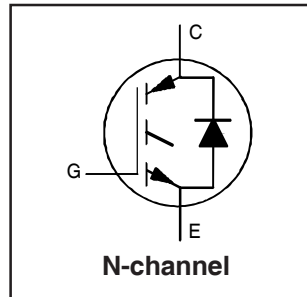

$V_{CES} = 1200V$
$V_{CE(on) typ.} = 2.28V$
$V_{GE} = 15V, I_C = 25A, 25^\circ C$

**Benefits**

- Benchmark Efficiency for Motor Control Applications
- Rugged Transient Performance
- Low EMI
- Significantly Less Snubber Required
- Excellent Current Sharing in Parallel Operation
- Longer leads for Easier Mounting

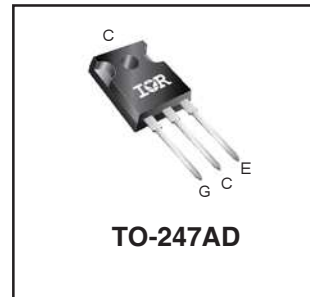

Base Part Number	Package Type	Standard Pack		Orderable Part Number
		Form	Quantity	
IRGP30B120KD-EP	TO-247AD	Tube	25	IRGP30B120KD-EP

**Absolute Maximum Ratings**

	Parameter	Max.	Units
$V_{CES}$	Collector-to-Emitter Breakdown Voltage	1200	V
$I_C @ T_C = 25^\circ C$	Continuous Collector Current (Fig.1)	60	A
$I_C @ T_C = 100^\circ C$	Continuous Collector Current (Fig.1)	30	
$I_{CM}$	Pulsed Collector Current (Fig.3, Fig. CT.5)	120	
$I_{LM}$	Clamped Inductive Load Current(Fig.4, Fig. CT.2)	120	
$I_F @ T_C = 100^\circ C$	Diode Continuous Forward Current	30	
$I_{FM}$	Diode Maximum Forward Current	120	W
$V_{GE}$	Gate-to-Emitter Voltage	$\pm 20$	
$P_D @ T_C = 25^\circ C$	Maximum Power Dissipation (Fig.2)	300	W
$P_D @ T_C = 100^\circ C$	Maximum Power Dissipation (Fig.2)	120	
$T_J$	Operating Junction and	-55 to + 150	°C
$T_{STG}$	Storage Temperature Range		
	Soldering Temperature, for 10 seconds	300, (0.063 in. (1.6mm) from case)	
	Mounting Torque, 6-32 or M3 screw.	10 lbf•in (1.1N•m)	

**Thermal Resistance**

	Parameter	Min.	Typ.	Max.	Units
$R_{\theta JC}$	Junction-to-Case - IGBT	—	—	0.42	°C/W
$R_{\theta JC}$	Junction-to-Case - Diode	—	—	0.83	
$R_{\theta CS}$	Case-to-Sink, flat, greased surface	—	0.24	—	
$R_{\theta JA}$	Junction-to-Ambient, typical socket mount	—	—	40	
$W_t$	Weight	—	6 (0.21)	—	g (oz)
$Z_{\theta JC}$	Transient Thermal Impedance Junction-to-Case (Fig.24)	—	—	—	—

**Electrical Characteristics @ T<sub>J</sub> = 25°C (unless otherwise specified)**

	Parameter	Min.	Typ.	Max.	Units	Conditions	Fig.
V <sub>(BR)CES</sub>	Collector-to-Emitter Breakdown Voltage	1200			V	V <sub>GE</sub> = 0V, I <sub>C</sub> = 250 μA	
ΔV <sub>(BR)CES</sub> / ΔT <sub>J</sub>	Temperature Coeff. of Breakdown Voltage		+1.2		V/°C	V <sub>GE</sub> = 0V, I <sub>C</sub> = 1 mA ( 25 -125 °C )	
V <sub>CE(on)</sub>	Collector-to-Emitter Saturation Voltage		2.28	2.48	V	I <sub>C</sub> = 25A, V <sub>GE</sub> = 15V	5, 6
			2.46	2.66		I <sub>C</sub> = 30A, V <sub>GE</sub> = 15V	7, 9
			3.43	4.00		I <sub>C</sub> = 60A, V <sub>GE</sub> = 15V	10
			2.74	3.10		I <sub>C</sub> = 25A, V <sub>GE</sub> = 15V, T <sub>J</sub> = 125°C	11
			2.98	3.35		I <sub>C</sub> = 30A, V <sub>GE</sub> = 15V, T <sub>J</sub> = 125°C	
V <sub>GE(th)</sub>	Gate Threshold Voltage	4.0	5.0	6.0	V	V <sub>CE</sub> = V <sub>GE</sub> , I <sub>C</sub> = 250 μA	9,10,11,12
ΔV <sub>GE(th)</sub> / ΔT <sub>J</sub>	Temperature Coeff. of Threshold Voltage		- 1.2		mV/°C	V <sub>CE</sub> = V <sub>GE</sub> , I <sub>C</sub> = 1 mA ( 25 -125 °C )	
g <sub>fe</sub>	Forward Transconductance	14.8	16.9	19.0	S	V <sub>CE</sub> = 50V, I <sub>C</sub> = 25A, PW=80μs	
I <sub>CES</sub>	Zero Gate Voltage Collector Current			250	μA	V <sub>GE</sub> = 0V, V <sub>CE</sub> = 1200V	
			325	675		V <sub>GE</sub> = 0v, V <sub>CE</sub> = 1200V, T <sub>J</sub> =125°C	
				2000		V <sub>GE</sub> = 0v, V <sub>CE</sub> = 1200V, T <sub>J</sub> =150°C	
V <sub>FM</sub>	Diode Forward Voltage Drop		1.76	2.06	V	I <sub>C</sub> = 25A	8
			1.86	2.17		I <sub>C</sub> = 30A	
			1.87	2.18		I <sub>C</sub> = 25A, T <sub>J</sub> = 125°C	
			2.01	2.40		I <sub>C</sub> = 30A, T <sub>J</sub> = 125°C	
I <sub>GES</sub>	Gate-to-Emitter Leakage Current			±100	nA	V <sub>GE</sub> = ±20V	

**Switching Characteristics @ T<sub>J</sub> = 25°C (unless otherwise specified)**

	Parameter	Min.	Typ.	Max.	Units	Conditions	Fig.
Q <sub>g</sub>	Total Gate charge (turn-on)		169	254	nC	I <sub>C</sub> = 25A	23
Q <sub>ge</sub>	Gate - Emitter Charge (turn-on)		19	29		V <sub>CC</sub> = 600V	CT 1
Q <sub>gc</sub>	Gate - Collector Charge (turn-on)		82	123		V <sub>GE</sub> = 15V	
E <sub>on</sub>	Turn-On Switching Loss		1066	1250	μJ	I <sub>C</sub> = 25A, V <sub>CC</sub> = 600V	CT 4
E <sub>off</sub>	Turn-Off Switching Loss		1493	1800		V <sub>GE</sub> = 15V, R <sub>g</sub> = 5Ω, L=200μH	WF1
E <sub>tot</sub>	Total Switching Loss		2559	3050		T <sub>J</sub> = 25°C, Energy losses include tail and diode reverse recovery	WF2
E <sub>on</sub>	Turn-on Switching Loss		1660	1856	μJ	I <sub>C</sub> = 25A, V <sub>CC</sub> = 600V	13, 15
E <sub>off</sub>	Turn-off Switching Loss		2118	2580		V <sub>GE</sub> = 15V, R <sub>g</sub> = 5Ω, L=200μH	CT 4
E <sub>tot</sub>	Total Switching Loss		3778	4436		T <sub>J</sub> = 125°C, Energy losses include tail and diode reverse recovery	WF1 & 2
td(on)	Turn - on delay time		50	65	ns	I <sub>C</sub> = 25A, V <sub>CC</sub> = 600V	14, 16
tr	Rise time		25	35		V <sub>GE</sub> = 15V, R <sub>g</sub> = 5Ω, L=200μH	CT 4
td(off)	Turn - off delay time		210	230		T <sub>J</sub> = 125°C,	WF1
tf	Fall time		60	75			WF2
C <sub>ies</sub>	Input Capacitance		2200		pF	V <sub>GE</sub> = 0V	22
C <sub>oes</sub>	Output Capacitance		210			V <sub>CC</sub> = 30V	
C <sub>res</sub>	Reverse Transfer Capacitance		85			f = 1.0 MHz	
RBSOA	Reverse bias safe operating area	FULL SQUARE				T <sub>J</sub> = 150°C, I <sub>C</sub> = 120A V <sub>CC</sub> = 1000V, V <sub>P</sub> = 1200V R <sub>g</sub> = 5Ω, V <sub>GE</sub> = +15V to 0 V	4 CT 2
SCSOA	Short Circuit Safe Operating Area	10	----	----	μs	T <sub>J</sub> = 150°C V <sub>CC</sub> = 900V, V <sub>P</sub> = 1200V R <sub>g</sub> = 5Ω, V <sub>GE</sub> = +15V to 0 V	CT 3 WF4
E <sub>rec</sub>	Reverse recovery energy of the diode		1820	2400	μJ	T <sub>J</sub> = 125°C	17,18,19
trr	Diode Reverse recovery time		300		ns	V <sub>CC</sub> = 600V, I <sub>C</sub> = 25A	20, 21
I <sub>rr</sub>	Peak Reverse Recovery Current		34	38	A	V <sub>GE</sub> = 15V, R <sub>g</sub> = 5Ω, L=200μH	CT 4, WF3
Le	Internal Emitter Inductance		13		nH	Measured 5 mm from the package.	

*Fig.1 - Maximum DC Collector Current vs. Case Temperature*

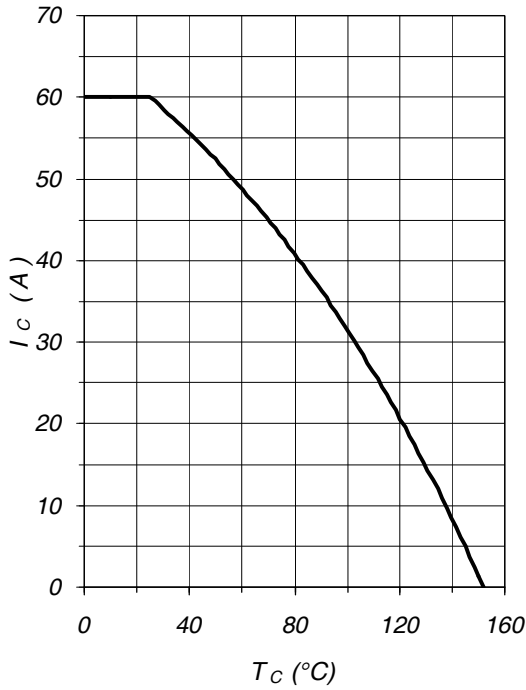

*Fig.2 - Power Dissipation vs. Case Temperature*

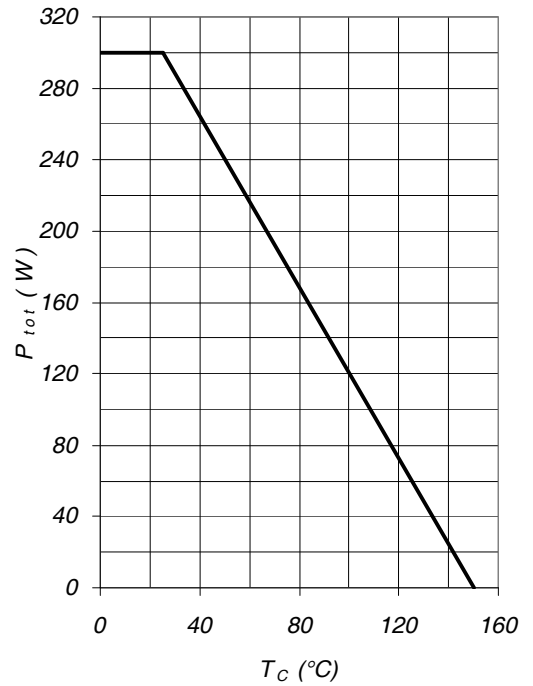

*Fig.3 - Forward SOA  
 $T_C=25^{\circ}C$ ;  $T_j \leq 150^{\circ}C$*

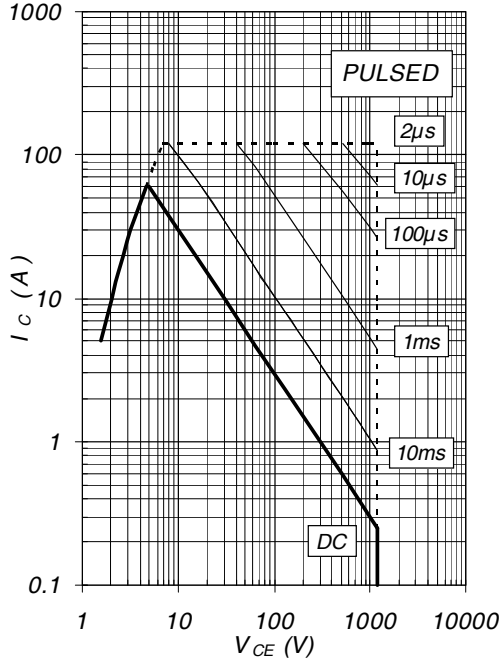

*Fig.4 - Reverse Bias SOA  
 $T_j = 150^{\circ}C$ ,  $V_{GE} = 15V$*

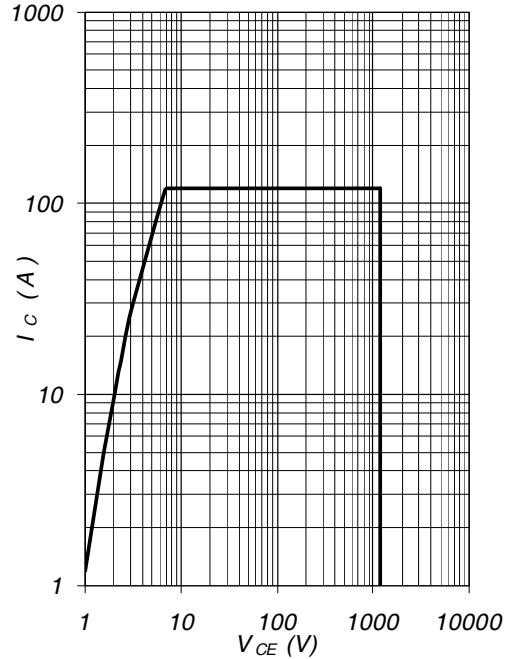

**Fig.5 - Typical IGBT Output Characteristics**  
 $T_j = -40^\circ\text{C}; t_p = 300\mu\text{s}$

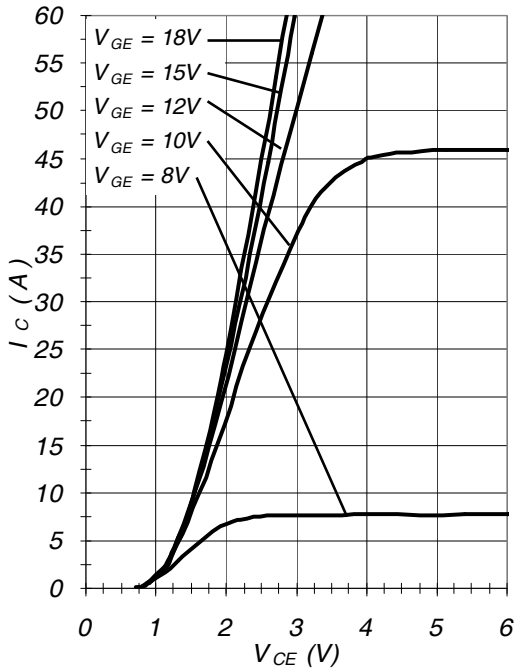

**Fig.6 - Typical IGBT Output Characteristics**  
 $T_j = 25^\circ\text{C}; t_p = 300\mu\text{s}$

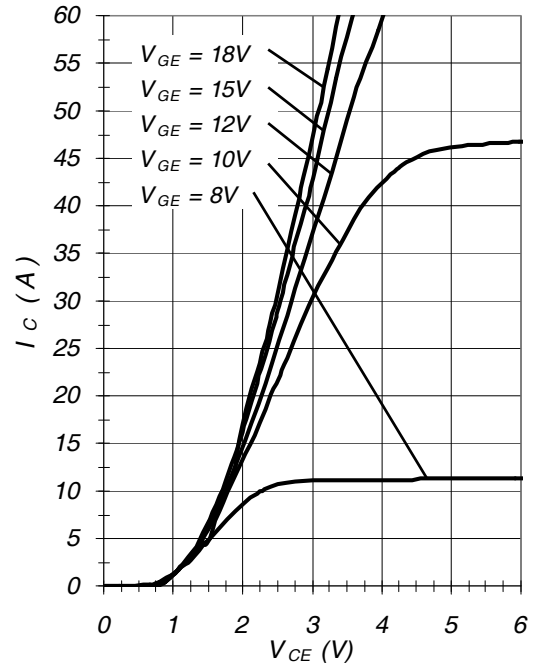

**Fig.7 - Typical IGBT Output Characteristics**  
 $T_j = 125^\circ\text{C}; t_p = 300\mu\text{s}$

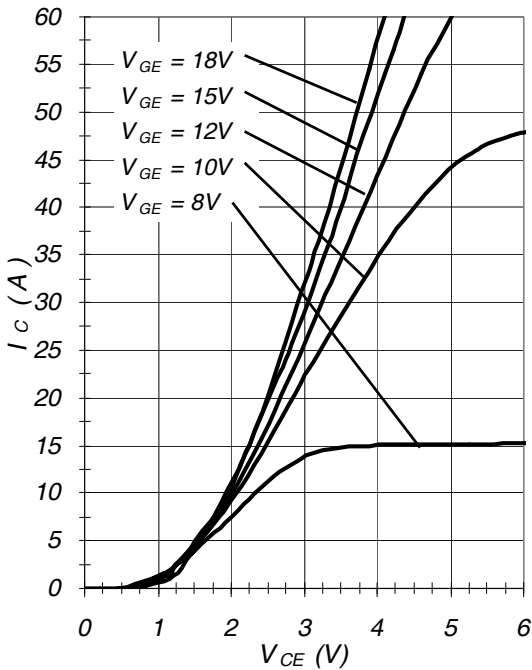

**Fig.8 - Typical Diode Forward Characteristic**  
 $t_p = 300\mu\text{s}$

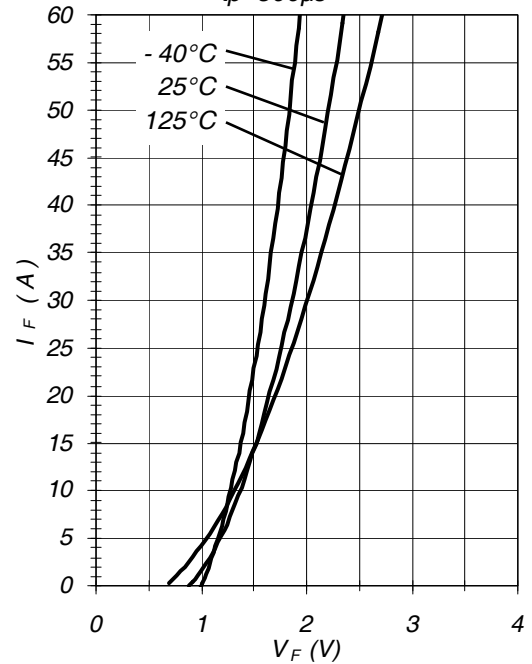

Fig.9 - Typical  $V_{CE}$  vs  $V_{GE}$   
 $T_j = -40^\circ\text{C}$

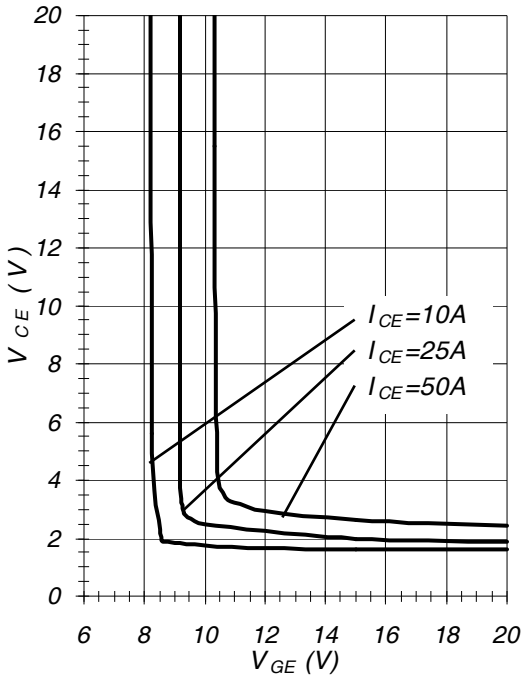

Fig.10 - Typical  $V_{CE}$  vs  $V_{GE}$   
 $T_j = 25^\circ\text{C}$

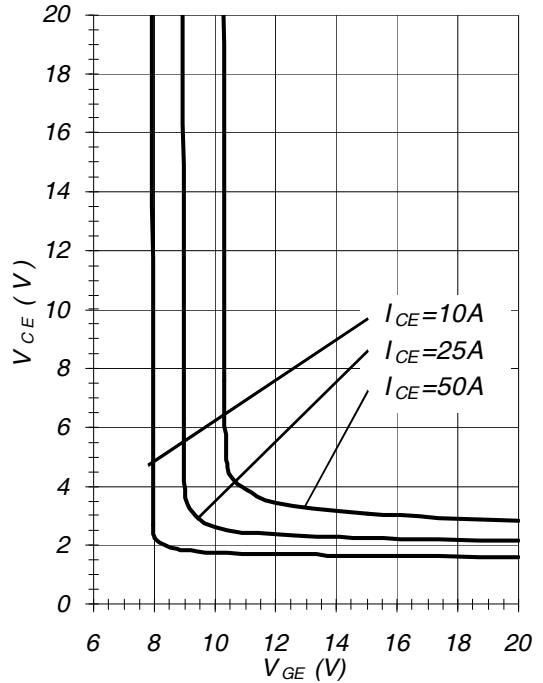

Fig.11 - Typical  $V_{CE}$  vs  $V_{GE}$   
 $T_j = 125^\circ\text{C}$

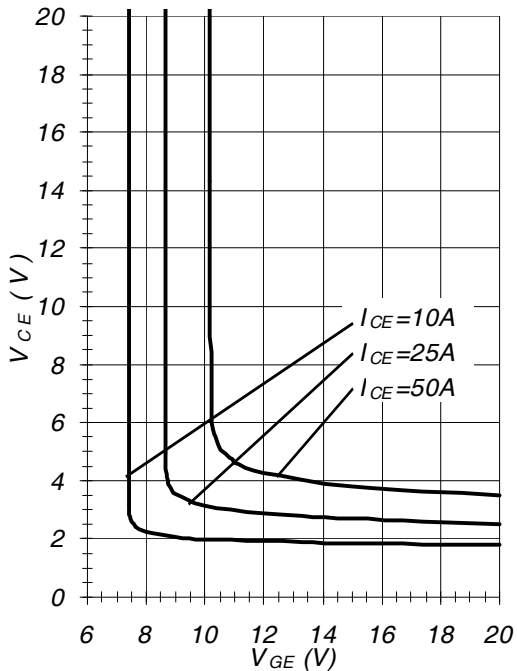

Fig.12 - Typ. Transfer Characteristics  
 $V_{CE} = 20\text{V}$ ;  $t_p = 20\mu\text{s}$

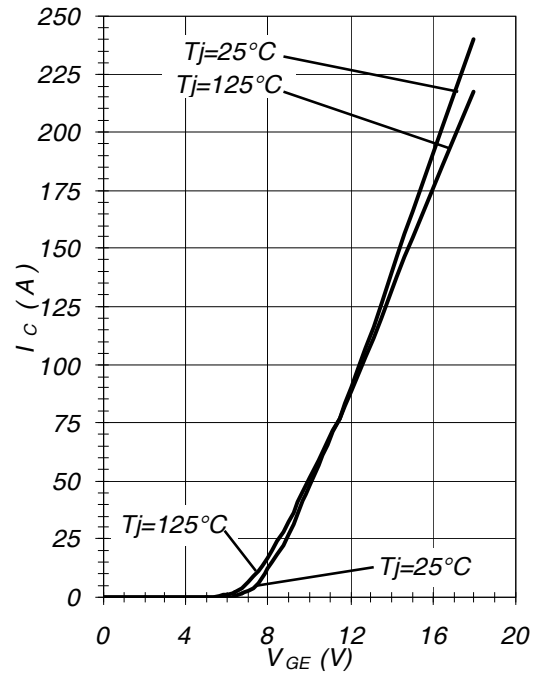

Fig.13 - Typical Energy Loss vs  $I_C$   
 $T_j=125^\circ\text{C}$ ;  $L=200\mu\text{H}$ ;  $V_{CE}=600\text{V}$ ;  
 $R_g=22\ \Omega$ ;  $V_{GE}=15\text{V}$

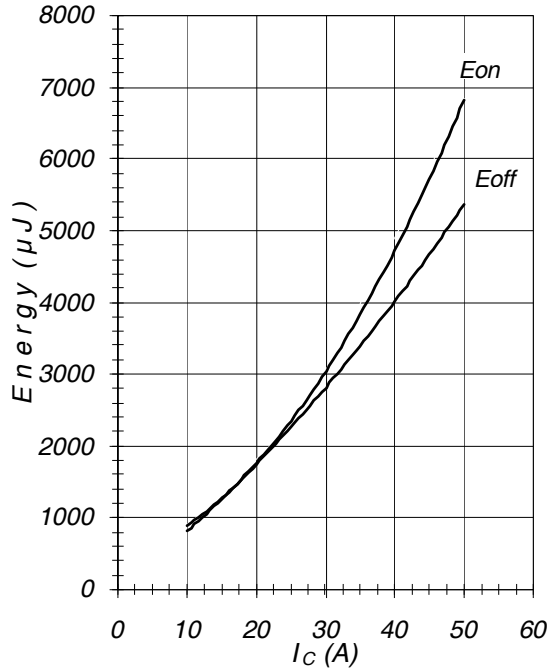

Fig.14 - Typical Switching Time vs  $I_C$   
 $T_j=125^\circ\text{C}$ ;  $L=200\mu\text{H}$ ;  $V_{CE}=600\text{V}$ ;  
 $R_g=22\ \Omega$ ;  $V_{GE}=15\text{V}$

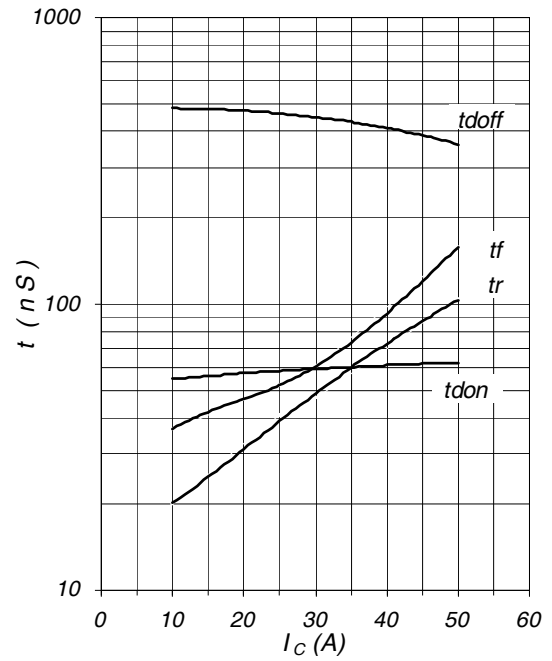

Fig.15 - Typical Energy Loss vs  $R_g$   
 $T_j=125^\circ\text{C}$ ;  $L=200\mu\text{H}$ ;  $V_{CE}=600\text{V}$ ;  
 $I_{CE}=25\text{A}$ ;  $V_{GE}=15\text{V}$

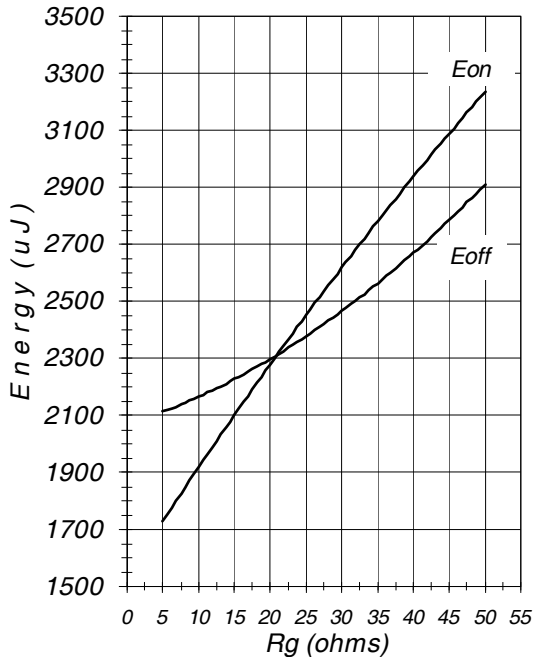

Fig.16 - Typical Switching Time vs  $R_g$   
 $T_j=125^\circ\text{C}$ ;  $L=200\mu\text{H}$ ;  $V_{CE}=600\text{V}$ ;  
 $I_{CE}=25\text{A}$ ;  $V_{GE}=15\text{V}$

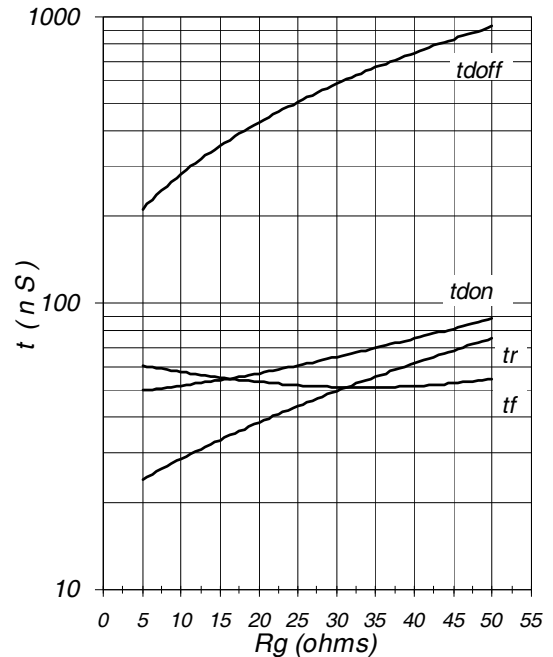

Fig.17 - Typical Diode  $I_{RR}$  vs  $I_F$   
 $T_j=125^\circ\text{C}$

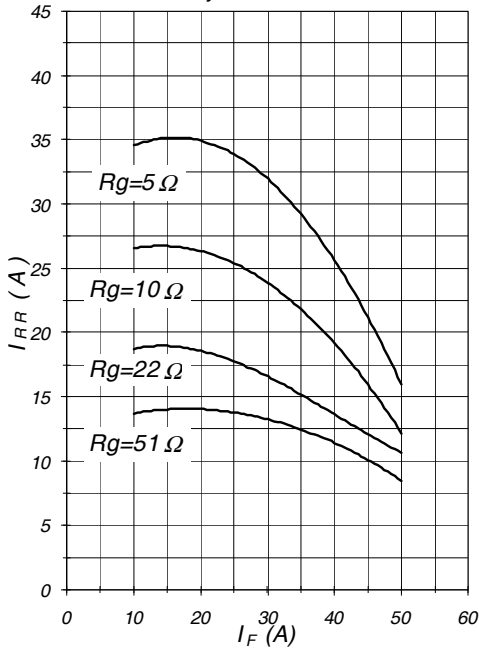

Fig.18 - Typical Diode  $I_{RR}$  vs  $R_g$   
 $T_j=125^\circ\text{C}; I_F=25\text{A}$

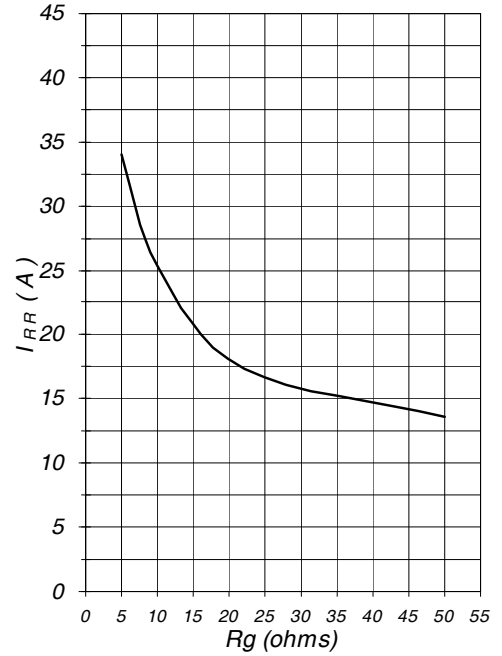

Fig.19 - Typical Diode  $I_{RR}$  vs  $di_F/dt$   
 $V_{CC}=600\text{V}; V_{GE}=15\text{V}$   
 $I_F=25\text{A}; T_j=125^\circ\text{C}$

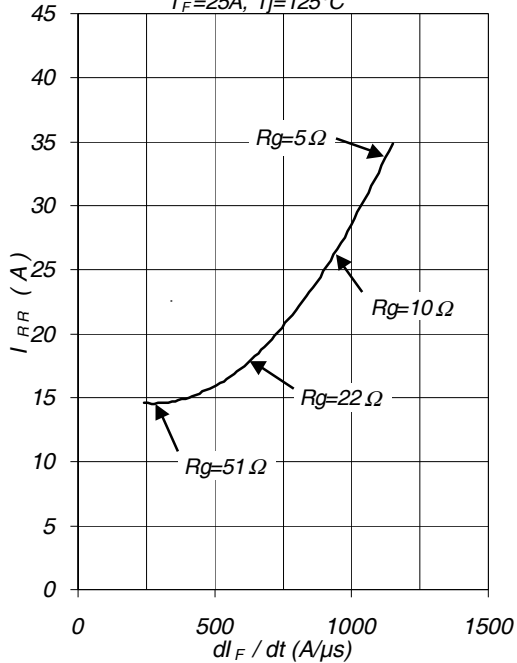

Fig.20 - Typical Diode  $Q_{RR}$   
 $V_{CC}=600\text{V}; V_{GE}=15\text{V}; T_j=125^\circ\text{C}$

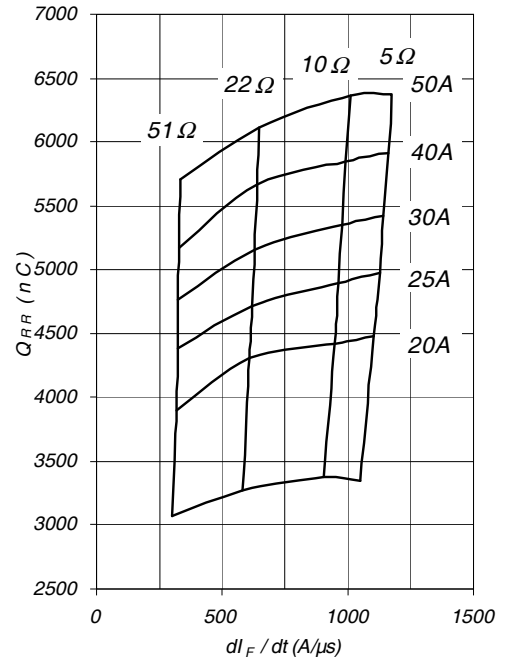



Fig.21 - Typ. Diode  $E_{rec}$  vs.  $I_F$   
 $T_j=125^\circ\text{C}$

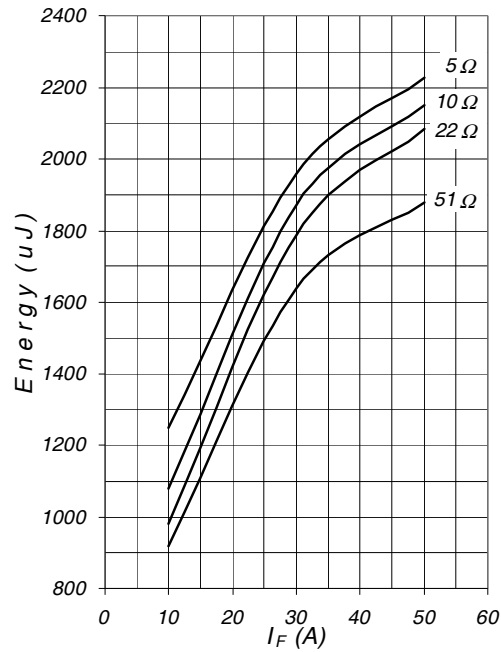

Fig.22 - Typical Capacitance vs  $V_{CE}$   
 $V_{GE}=0\text{V}$ ;  $f=1\text{MHz}$

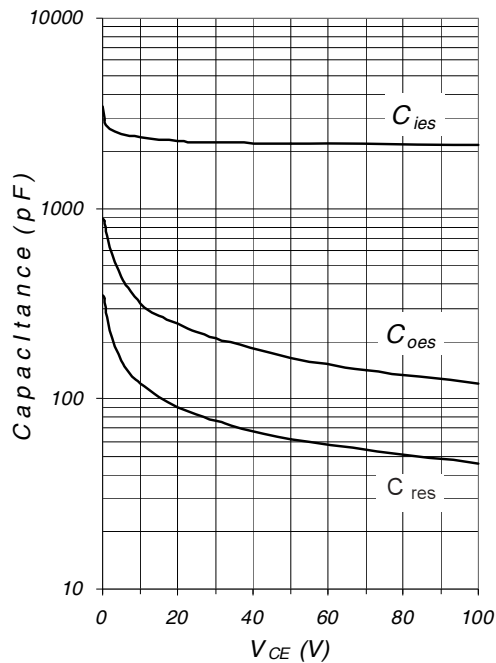

Fig.23 - Typ. Gate Charge vs.  $V_{GE}$   
 $I_C=25\text{A}$ ;  $L=600\mu\text{H}$

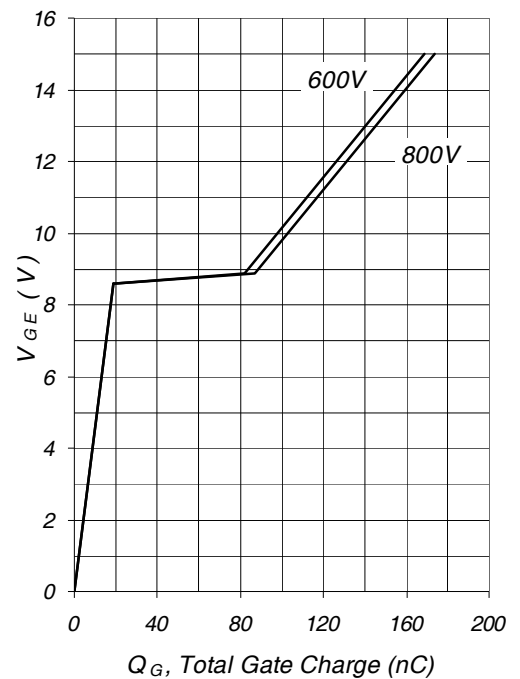
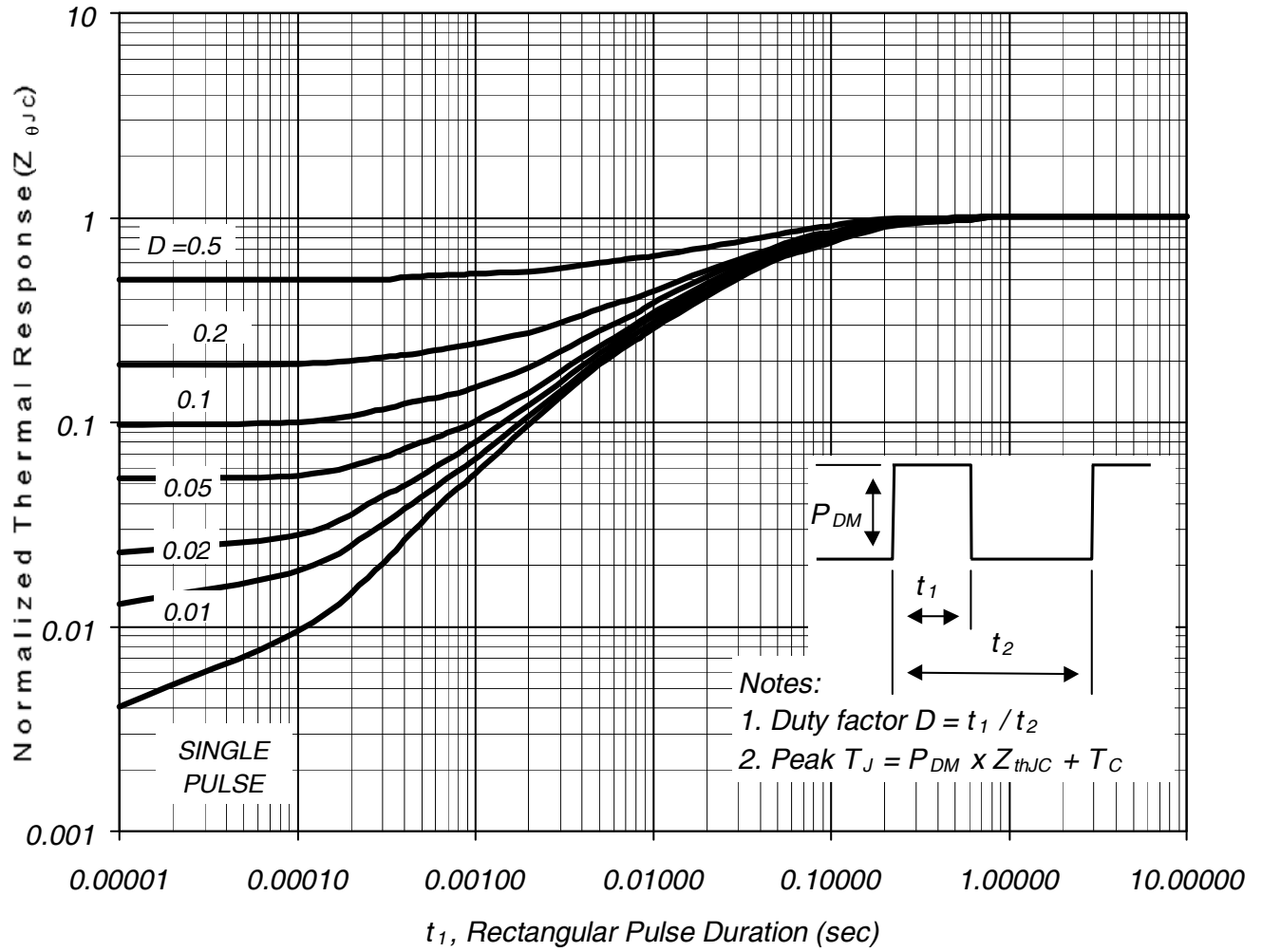

Fig.24 - Normalized Transient Thermal Impedance, Junction-to-Case



**Fig. CT.1 - Gate Charge Circuit (turn-off)**

**Fig. CT.2 - RBSOA Circuit**

**Fig. CT.3 - S.C. SOA Circuit**

**Fig. CT.4 - Switching Loss Circuit**

**Fig. CT.5 - Resistive Load Circuit**

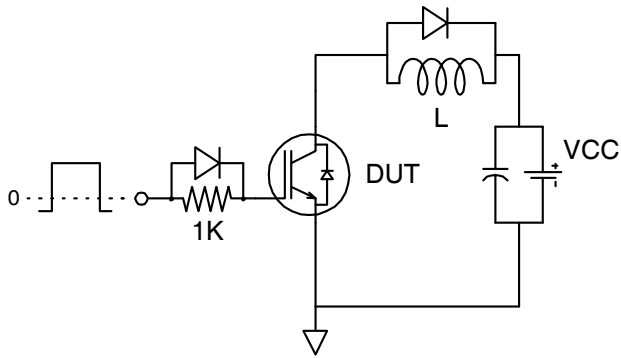
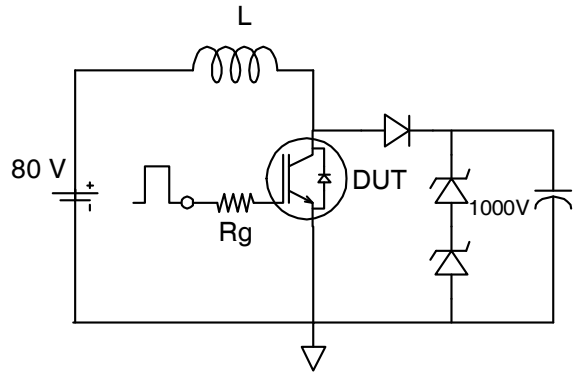
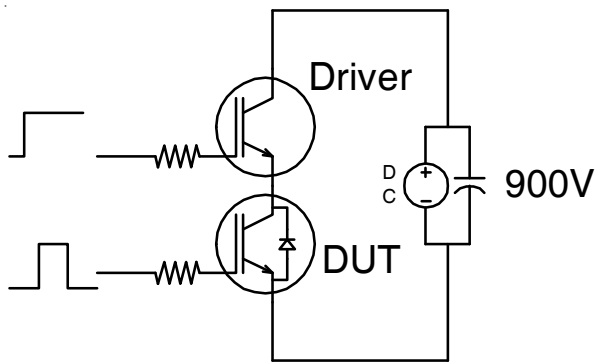
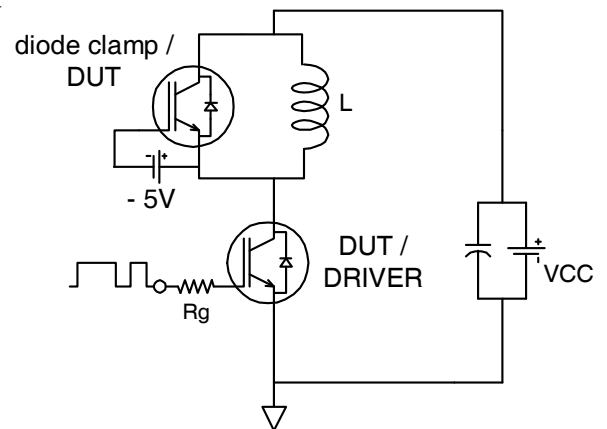
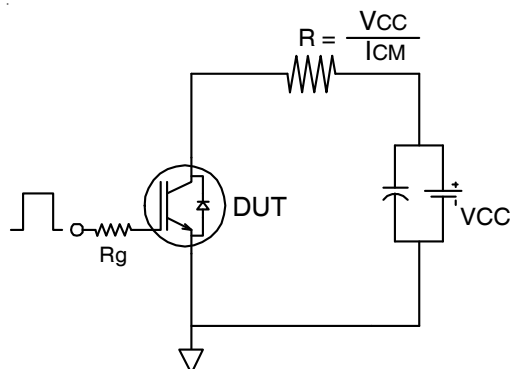
Fig. WF.1 - Typ. Turn-off Loss Waveform  
@  $T_j=125^\circ\text{C}$  using Fig. CT.4

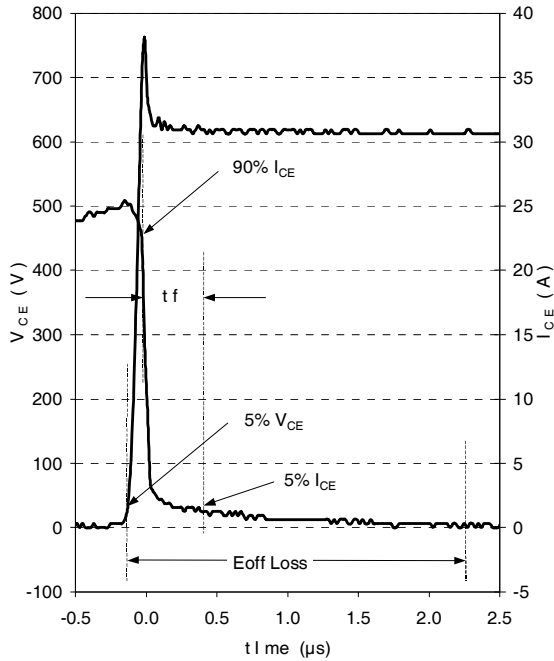

Fig. WF.2 - Typ. Turn-on Loss Waveform  
@  $T_j=125^\circ\text{C}$  using Fig. CT.4

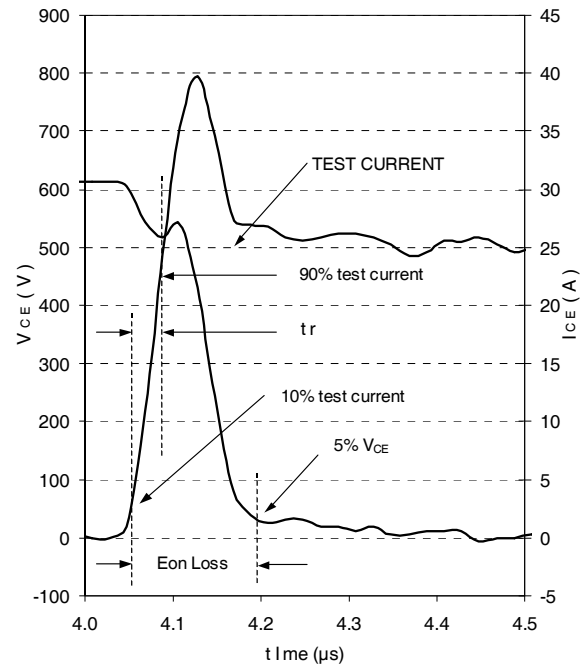

Fig. WF.3 - Typ. Diode Recovery Waveform  
@  $T_j=125^\circ\text{C}$  using Fig. CT.4

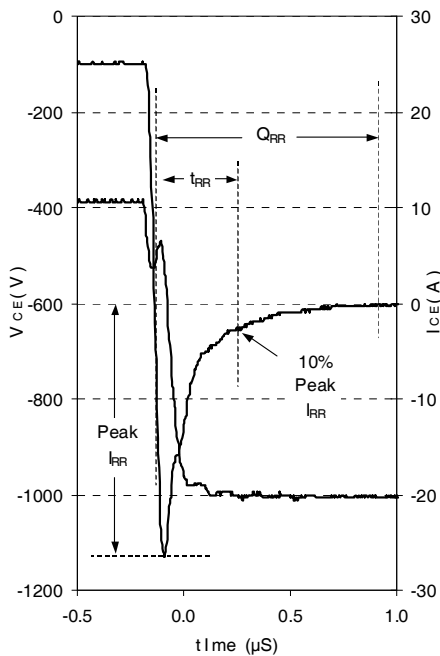
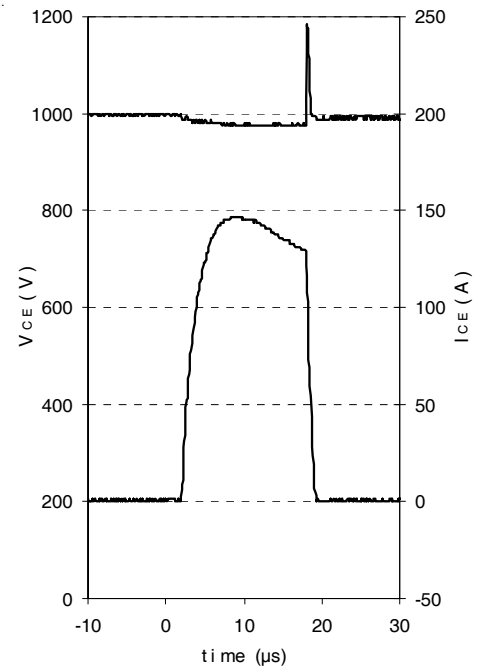
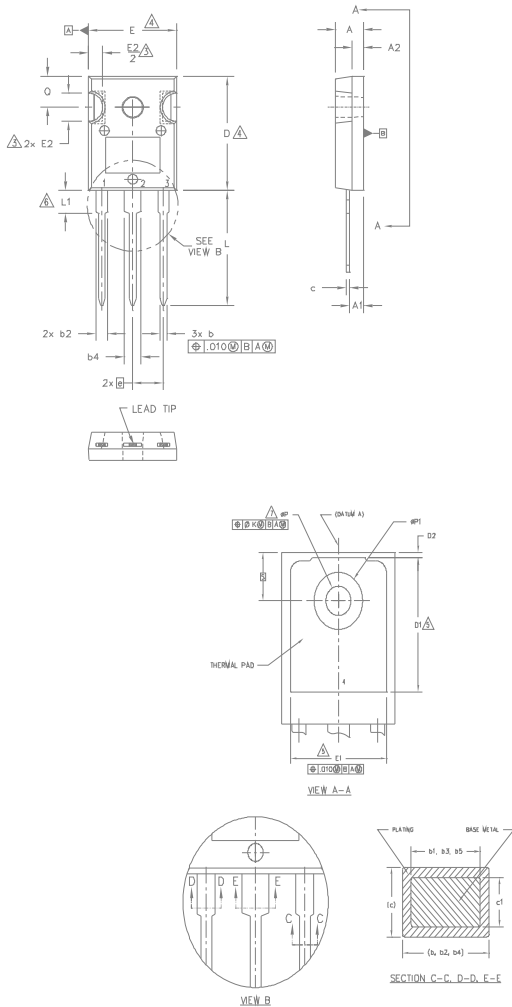

Fig. WF.4 - Typ. S.C. Waveform  
@  $T_C=150^\circ\text{C}$  using Fig. CT.3



**TO-247AD Package Outline** (Dimensions are shown in millimeters (inches))

**NOTES:**

1. DIMENSIONING AND TOLERANCING AS PER ASME Y14.5M 1994.
2. DIMENSIONS ARE SHOWN IN INCHES.
3. CONTOUR OF SLOT OPTIONAL.
4. DIMENSION D & E DO NOT INCLUDE MOLD FLASH. MOLD FLASH SHALL NOT EXCEED .005" (0.127) PER SIDE. THESE DIMENSIONS ARE MEASURED AT THE OUTERMOST EXTREMES OF THE PLASTIC BODY.
5. THERMAL PAD CONTOUR OPTIONAL WITHIN DIMENSIONS D1 & E1.
6. LEAD FINISH UNCONTROLLED IN L1.
7.  $\phi P$  TO HAVE A MAXIMUM DRAFT ANGLE OF 1.5 ° TO THE TOP OF THE PART WITH A MAXIMUM HOLE DIAMETER OF .154 INCH.
8. OUTLINE CONFORMS TO JEDEC OUTLINE TO-247AD.

SYMBOL	DIMENSIONS				NOTES
	INCHES		MILLIMETERS		
	MIN.	MAX.	MIN.	MAX.	
A	.190	.203	4.83	5.13	
A1	.087	.102	2.21	2.59	
A2	.059	.098	1.50	2.49	
b	.039	.055	0.99	1.40	
b1	.039	.053	0.99	1.35	
b2	.065	.094	1.65	2.39	
b3	.065	.092	1.65	2.34	
b4	.102	.135	2.59	3.43	
b5	.102	.133	2.59	3.38	
c	.015	.035	0.38	0.89	
c1	.015	.033	0.38	0.84	
D	.776	.815	19.71	20.70	4
D1	.515	-	13.08	-	5
D2	.020	.053	0.51	1.35	
E	.602	.625	15.29	15.87	4
E1	.530	-	13.46	-	
E2	.178	.216	4.52	5.49	
e	.215 BSC		5.46 BSC		
$\phi k$	.010		0.25		
L	.780	.827	19.57	21.00	
L1	.146	.169	3.71	4.29	
$\phi P$	.140	.144	3.56	3.66	
$\phi P1$	-	.291	-	7.39	
Q	.209	.224	5.31	5.69	
S	.217 BSC		5.51 BSC		

**LEAD ASSIGNMENTS**
**HEXFET**

- 1.- GATE
- 2.- DRAIN
- 3.- SOURCE
- 4.- DRAIN

**IGBTs, CoPACK**

- 1.- GATE
- 2.- COLLECTOR
- 3.- EMITTER
- 4.- COLLECTOR

**DIODES**

- 1.- ANODE/OPEN
- 2.- CATHODE
- 3.- ANODE

**TO-247AD Part Marking Information**

EXAMPLE: THIS IS AN IRGP30B120KD-E  
WITH ASSEMBLY  
LOT CODE 5657  
ASSEMBLED ON WW 35, 2000  
IN THE ASSEMBLY LINE "H"

Note: "P" in assembly line position  
indicates "Lead-Free"

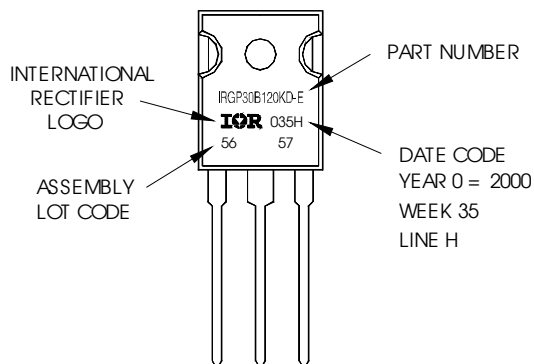

Note: For the most current drawing please refer to IR website at: <http://www.irf.com/package/>

**Qualification information<sup>†</sup>**

Qualification level	Industrial (per JEDEC JESD47F <sup>††</sup> guidelines)	
Moisture Sensitivity Level	TO-247AD	N/A
RoHS compliant	Yes	

<sup>†</sup> Qualification standards can be found at International Rectifier's web site: <http://www.irf.com/product-info/reliability>

<sup>††</sup> Applicable version of JEDEC standard at the time of product release

**Revision History**

Date	Comment
5/29/2014	<ul style="list-style-type: none"> <li>• Updated data sheet with IR corporate template.</li> <li>• Updated package outline on page 12.</li> <li>• Added pin assignment "G,C,E" on page 1.</li> <li>• Added Qualification table -Qual level "Industrial" on page 13.</li> </ul>