



Chipsmall Limited consists of a professional team with an average of over 10 year of expertise in the distribution of electronic components. Based in Hongkong, we have already established firm and mutual-benefit business relationships with customers from,Europe,America and south Asia,supplying obsolete and hard-to-find components to meet their specific needs.

With the principle of “Quality Parts,Customers Priority,Honest Operation,and Considerate Service”,our business mainly focus on the distribution of electronic components. Line cards we deal with include Microchip,ALPS,ROHM,Xilinx,Pulse,ON,Everlight and Freescale. Main products comprise IC,Modules,Potentiometer,IC Socket,Relay,Connector.Our parts cover such applications as commercial,industrial, and automotives areas.

We are looking forward to setting up business relationship with you and hope to provide you with the best service and solution. Let us make a better world for our industry!



Contact us

Tel: +86-755-8981 8866 Fax: +86-755-8427 6832

Email & Skype: info@chipsmall.com Web: www.chipsmall.com

Address: A1208, Overseas Decoration Building, #122 Zhenhua RD., Futian, Shenzhen, China



IRGPS40B120UP

INSULATED GATE BIPOLAR TRANSISTOR

UltraFast IGBT

Features

- Non Punch Through IGBT Technology.
- 10µs Short Circuit Capability.
- Square RBSOA.
- Positive VCE (on) Temperature Coefficient.
- Super-247 Package.
- Lead-Free

Benefits

- Benchmark Efficiency for Motor Control.
- Rugged Transient Performance.
- Low EMI.
- Significantly Less Snubber Required
- Excellent Current Sharing in Parallel Operation.

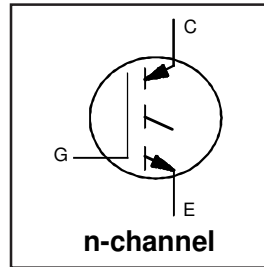

$V_{CES} = 1200V$
$V_{CE(on)} \text{ typ.} = 3.12V$
@ $V_{GE} = 15V,$
$I_{CE} = 40A, T_j = 25^\circ C$

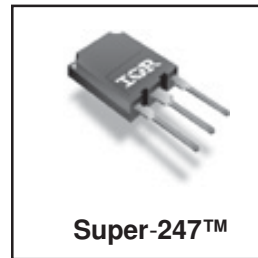

Absolute Maximum Ratings

	Parameter	Max.	Units
V_{CES}	Collector-to-Emitter Voltage	1200	V
$I_C @ T_C = 25^\circ C$	Continuous Collector Current	80	A
$I_C @ T_C = 100^\circ C$	Continuous Collector Current	40	
I_{CM}	Pulsed Collector Current	160	
I_{LM}	Clamped Inductive Load Current $\text{\textcircled{D}}$	160	
V_{GE}	Gate-to-Emitter Voltage	± 20	V
$P_D @ T_C = 25^\circ C$	Maximum Power Dissipation	595	W
$P_D @ T_C = 100^\circ C$	Maximum Power Dissipation	238	
T_J	Operating Junction and	-55 to +150	$^\circ C$
T_{STG}	Storage Temperature Range		
	Soldering Temperature, for 10 sec.	300 (0.063 in. (1.6mm) from case)	

Thermal Resistance

	Parameter	Min.	Typ.	Max.	Units
$R_{\theta JC}$	Junction-to-Case - IGBT	—	—	0.20	$^\circ C/W$
$R_{\theta CS}$	Case-to-Sink, flat, greased surface	—	0.24	—	
$R_{\theta JA}$	Junction-to-Ambient, typical socket mount	—	—	40	
	Recommended Clip Force	20 (2)	—	—	N(kgf)
Wt	Weight	—	6.0 (0.21)	—	g (oz)
Le	Internal Emitter Inductance (5mm from package)	—	13	—	nH

IRGPS40B120UP

Electrical Characteristics @ T_J = 25°C (unless otherwise specified)

	Parameter	Min.	Typ.	Max.	Units	Conditions	Ref.Fig.
V _{(BR)CES}	Collector-to-Emitter Breakdown Voltage	1200	—	—	V	V _{GE} = 0V, I _C = 500μA	
ΔV _{(BR)CES} /ΔT _J	Temperature Coeff. of Breakdown Voltage	—	0.40	—	V/°C	V _{GE} = 0V, I _C = 1.0mA, (25°C-125°C)	
V _{CE(on)}	Collector-to-Emitter Saturation Voltage	—	3.12	3.40	V	I _C = 40A I _C = 50A I _C = 40A, T _J = 125°C I _C = 50A, T _J = 125°C	5, 6
		—	3.39	3.71			7, 9
		—	3.88	4.39			10
		—	4.24	4.79			11
V _{GE(th)}	Gate Threshold Voltage	4.0	5.0	6.0		V _{CE} = V _{GE} , I _C = 250μA	8, 9
ΔV _{GE(th)} /ΔT _J	Temperature Coeff. of Threshold Voltage	—	-12	—	mV/°C	V _{CE} = V _{GE} , I _C = 1.0mA, (25°C-125°C)	10, 11
g _{fe}	Forward Transconductance	—	30.5	—	S	V _{CE} = 50V, I _C = 40A, PW=80μs	
I _{CES}	Zero Gate Voltage Collector Current	—	—	500	μA	V _{GE} = 0V, V _{CE} = 1200V	
		—	100	1200		V _{GE} = 0V, V _{CE} = 1200V, T _J = 125°C	
I _{GES}	Gate-to-Emitter Leakage Current	—	—	±100	nA	V _{GE} = ±20V	

Switching Characteristics @ T_J = 25°C (unless otherwise specified)

	Parameter	Min.	Typ.	Max.	Units	Conditions	Ref.Fig.
Q _g	Total Gate Charge (turn-on)	—	340	510	nC	I _C = 40A V _{CC} = 600V V _{GE} = 15V	17
Q _{ge}	Gate - Emitter Charge (turn-on)	—	43	65			CT1
Q _{gc}	Gate - Collector Charge (turn-on)	—	165	248			
E _{on}	Turn-On Switching Loss	—	1400	1750	μJ	I _C = 40A, V _{CC} = 600V V _{GE} = 15V, R _G = 4.7Ω, L = 200μH L _s = 150nH	CT4
E _{off}	Turn-Off Switching Loss	—	1650	2050			WF1
E _{tot}	Total Switching Loss	—	3050	3800	μJ	T _J = 25°C T _J = 125°C	WF2
E _{on}	Turn-On Switching Loss	—	1950	2300			12, 14
E _{off}	Turn-Off Switching Loss	—	2200	2950	μJ	Energy losses include "tail" and diode reverse recovery.	
E _{tot}	Total Switching Loss	—	4150	5250			
t _{d(on)}	Turn-On Delay Time	—	76	99	ns	I _C = 40A, V _{CC} = 600V V _{GE} = 15V, R _G = 4.7Ω, L = 200μH L _s = 150nH, T _J = 125°C	13, 15
t _r	Rise Time	—	39	55			CT4
t _{d(off)}	Turn-Off Delay Time	—	332	365			WF1
t _f	Fall Time	—	25	33			WF2
C _{ies}	Input Capacitance	—	4300	—	pF	V _{GE} = 0V V _{CC} = 30V f = 1.0MHz	16
C _{oes}	Output Capacitance	—	270	—			
C _{res}	Reverse Transfer Capacitance	—	160	—			
RBSOA	Reverse Bias Safe Operating Area	FULL SQUARE				T _J = 150°C, I _C = 160A, V _p = 1200V V _{CC} = 1000V, V _{GE} = +15V to 0V R _G = 4.7Ω	4
SCSOA	Short Circuit Safe Operating Area	10	—	—	μs	T _J = 150°C, V _p = 1200V V _{CC} = 900V, V _{GE} = +15V to 0V, R _G = 4.7Ω	CT3 WF4

Note:

⊙ V_{CC} = 80% (V_{CES}), V_{GE} = 20V, L = 100μH, R_G = 4.7Ω.

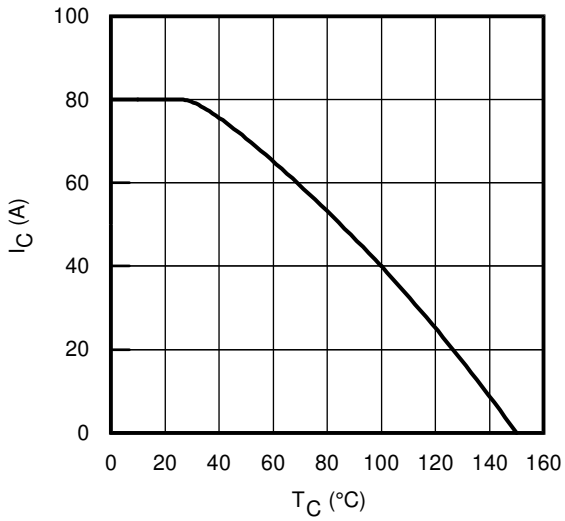

Fig. 1 - Maximum DC Collector Current vs. Case Temperature

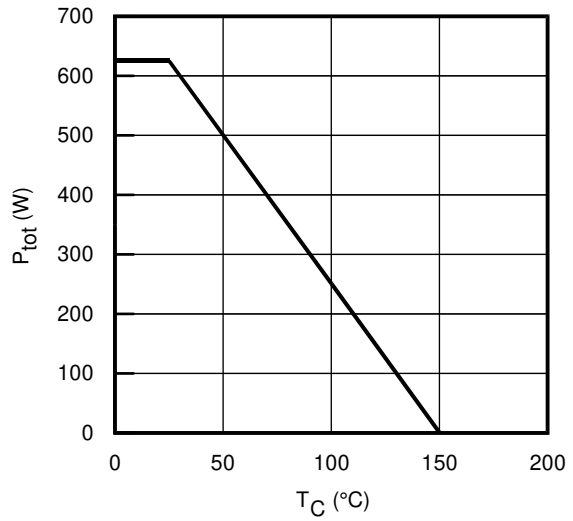

Fig. 2 - Power Dissipation vs. Case Temperature

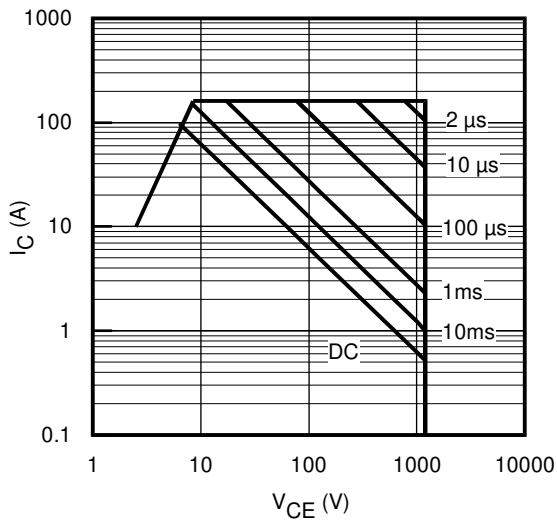

Fig. 3 - Forward SOA
 $T_C = 25^{\circ}C$; $T_{JS} \leq 150^{\circ}C$

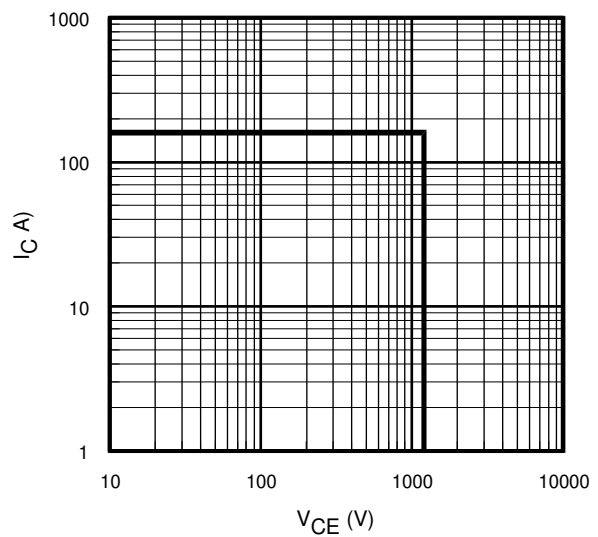

Fig. 4 - Reverse Bias SOA
 $T_J = 150^{\circ}C$; $V_{GE} = 15V$

IRGPS40B120UP

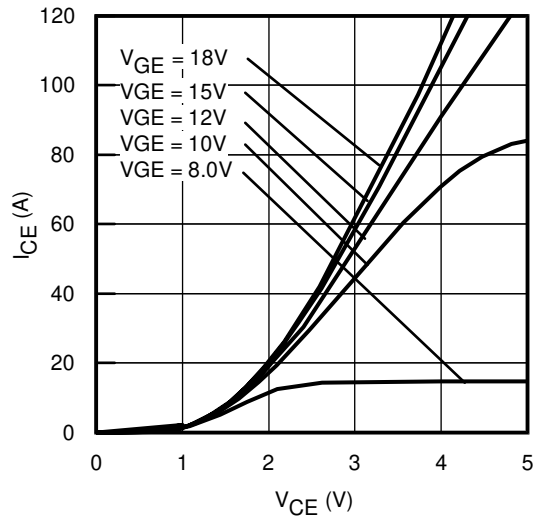

Fig. 5 - Typ. IGBT Output Characteristics
 $T_J = -40^\circ\text{C}$; $t_p = 80\mu\text{s}$

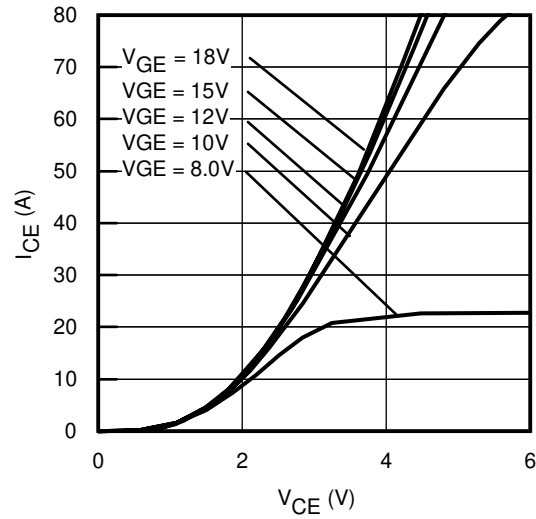

Fig. 6 - Typ. IGBT Output Characteristics
 $T_J = 25^\circ\text{C}$; $t_p = 80\mu\text{s}$

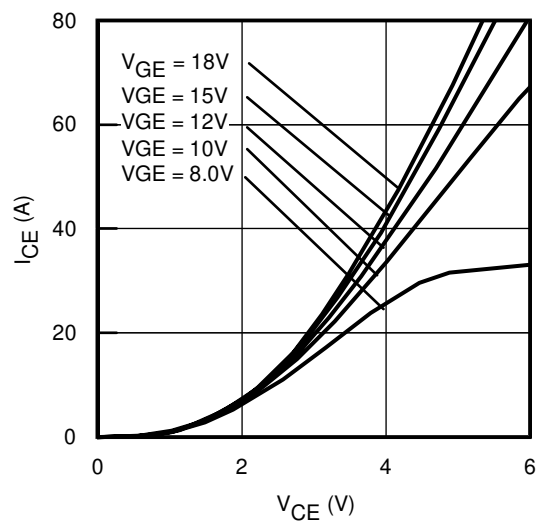

Fig. 7 - Typ. IGBT Output Characteristics
 $T_J = 125^\circ\text{C}$; $t_p = 80\mu\text{s}$

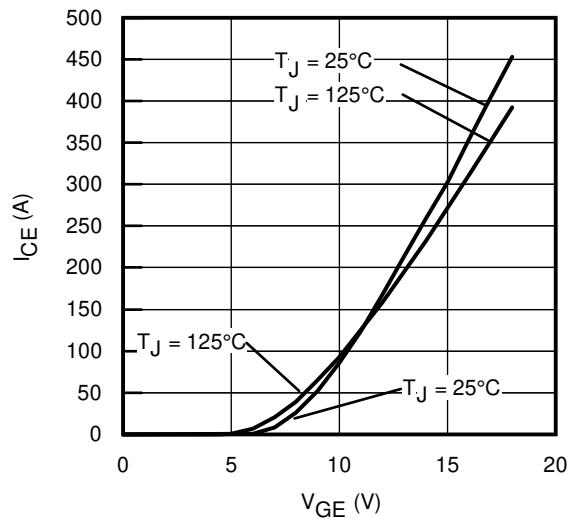

Fig. 8 - Typ. Transfer Characteristics
 $V_{CE} = 50\text{V}$; $t_p = 10\mu\text{s}$

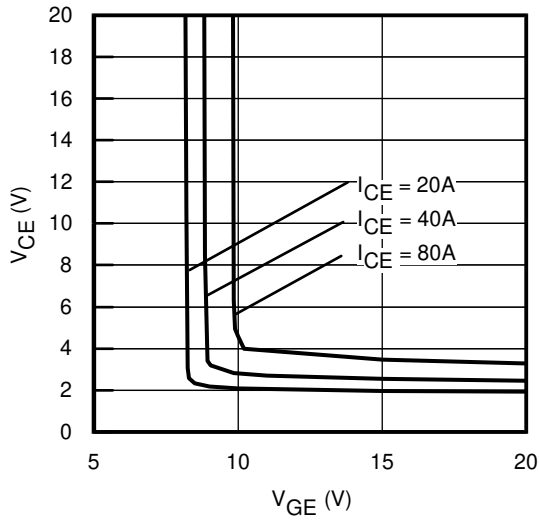

Fig. 9 - Typical V_{CE} vs. V_{GE}
 $T_J = -40^\circ\text{C}$

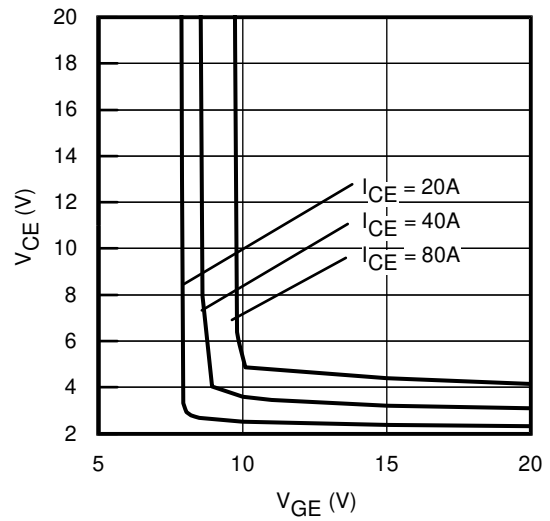

Fig. 10 - Typical V_{CE} vs. V_{GE}
 $T_J = 25^\circ\text{C}$

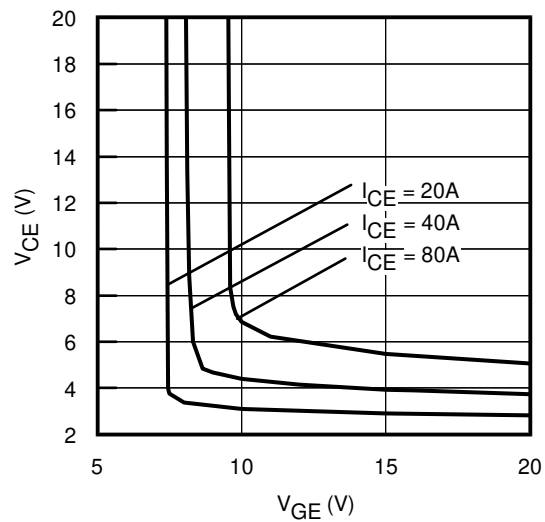

Fig. 11 - Typical V_{CE} vs. V_{GE}
 $T_J = 125^\circ\text{C}$

IRGPS40B120UP

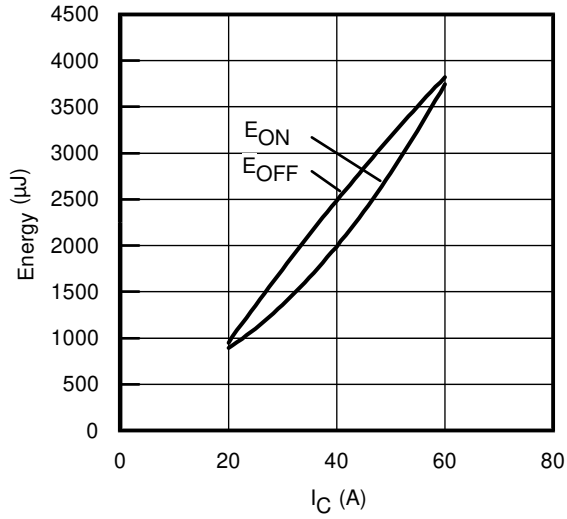

Fig. 12 - Typ. Energy Loss vs. I_C
T_J = 125°C; L=200μH; V_{CE}= 600V
R_G= 4.7Ω; V_{GE}= 15V

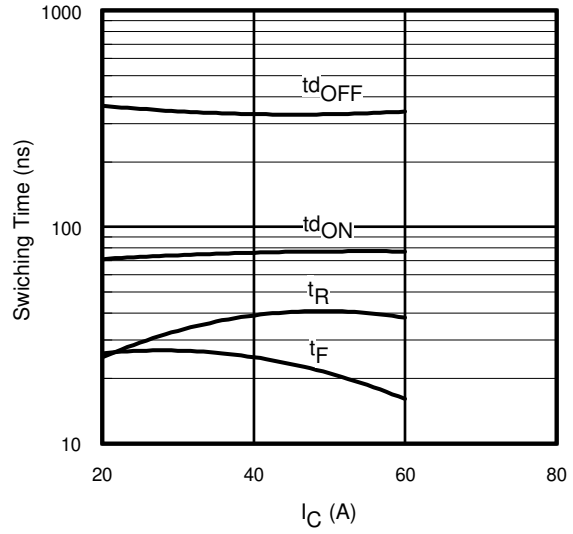

Fig. 13 - Typ. Switching Time vs. I_C
T_J = 125°C; L=200μH; V_{CE}= 600V
R_G= 4.7Ω; V_{GE}= 15V

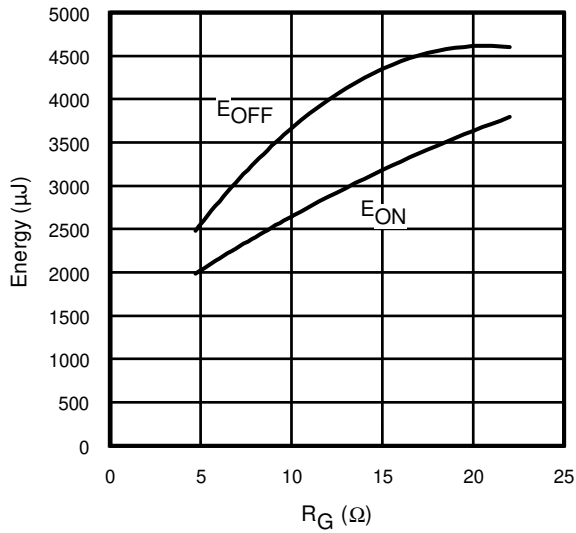

Fig. 14 - Typ. Energy Loss vs. R_G
T_J = 125°C; L=200μH; V_{CE}= 600V
I_{CE}= 40A; V_{GE}= 15V

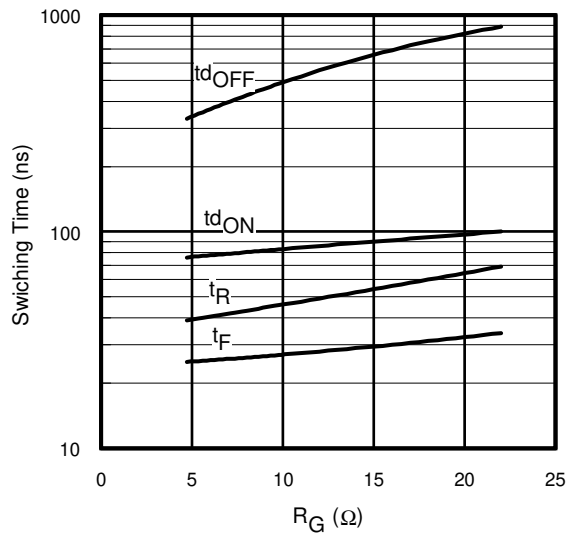

Fig. 15 - Typ. Switching Time vs. R_G
T_J = 125°C; L=200μH; V_{CE}= 600V
I_{CE}= 40A; V_{GE}= 15V

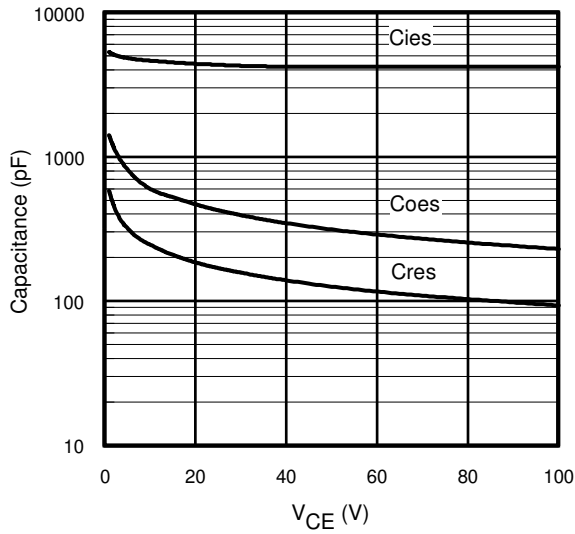

Fig. 16- Typ. Capacitance vs. V_{CE}
 $V_{GE} = 0V$; $f = 1MHz$

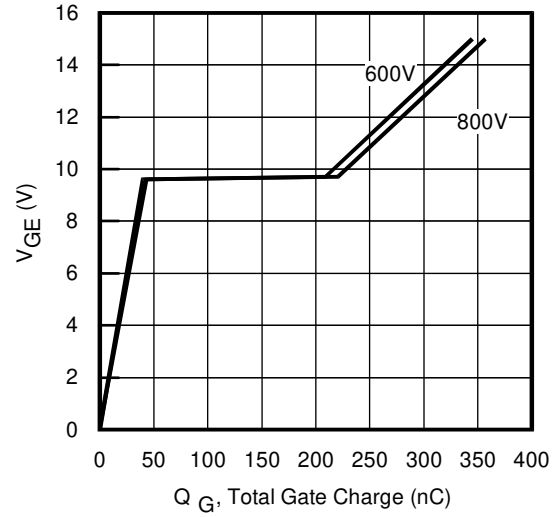

Fig. 17 - Typical Gate Charge vs. V_{GE}
 $I_{CE} = 40A$; $L = 600\mu H$

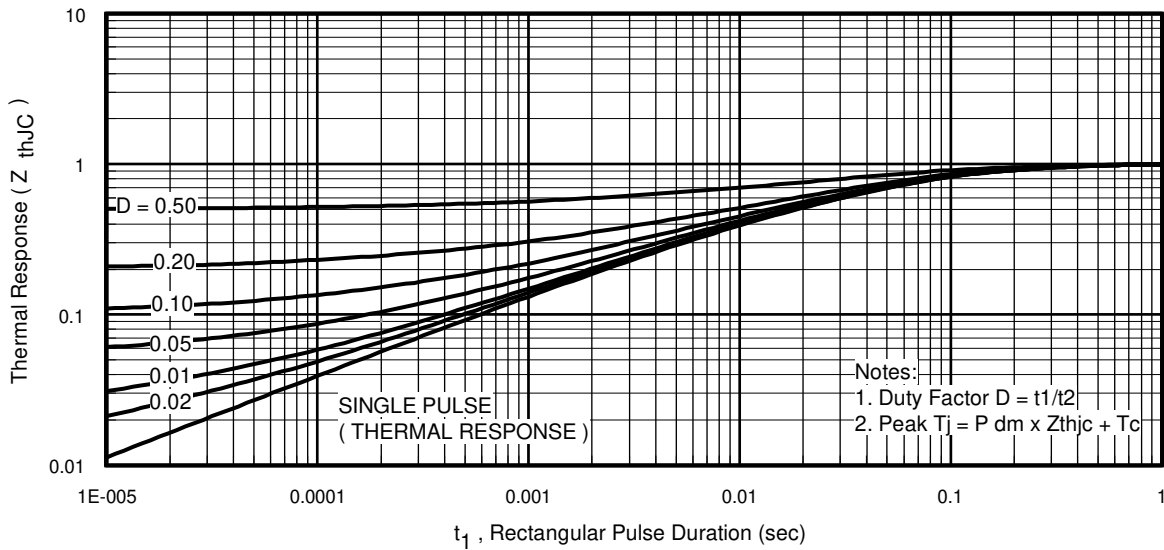

Fig 18. Normalized Transient Thermal Impedance, Junction-to-Case (IGBT)

IRGPS40B120UP

International
IR Rectifier

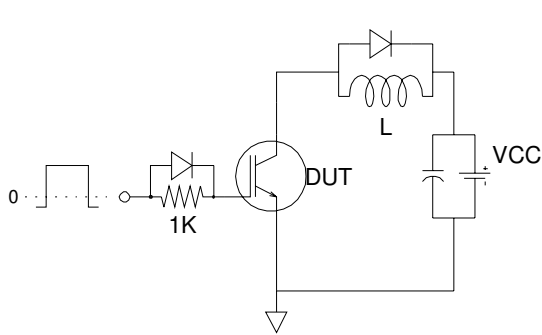

Fig.C.T.1 - Gate Charge Circuit (turn-on)

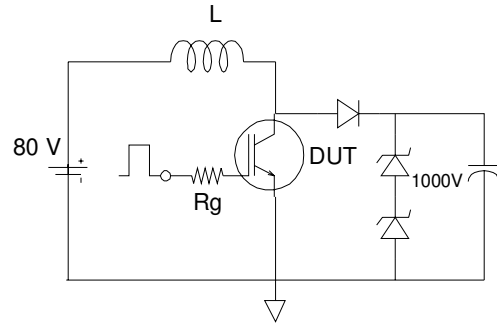

Fig.C.T.2 - RBSOA Circuit

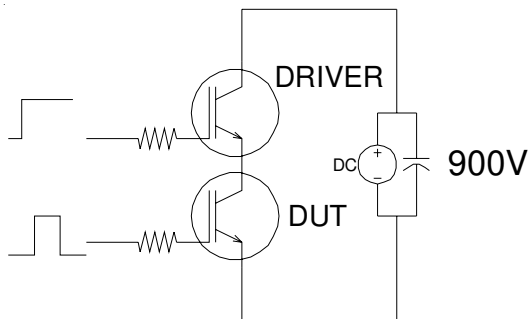

Fig.C.T.3 - S.C. SOA Circuit

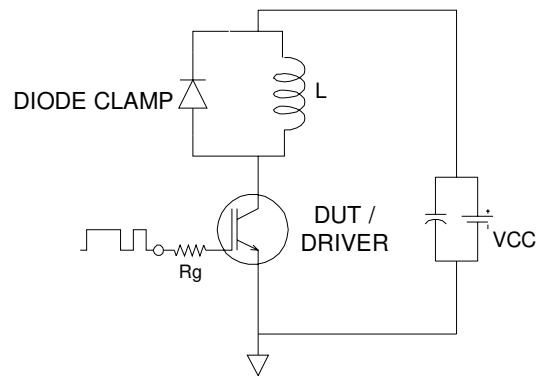

Fig.C.T.4 - Switching Loss Circuit

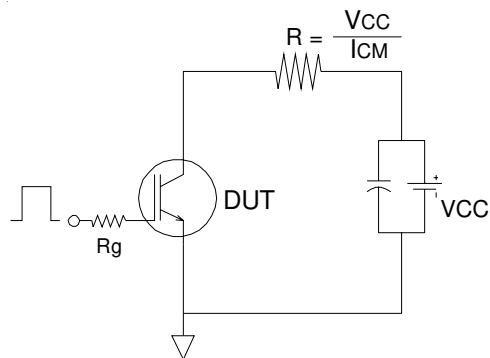

Fig.C.T.5 - Resistive Load Circuit

Fig. WF.1 - Typ. Turn-off Loss Waveform
@ $T_j=125^\circ\text{C}$ using Fig. CT.4

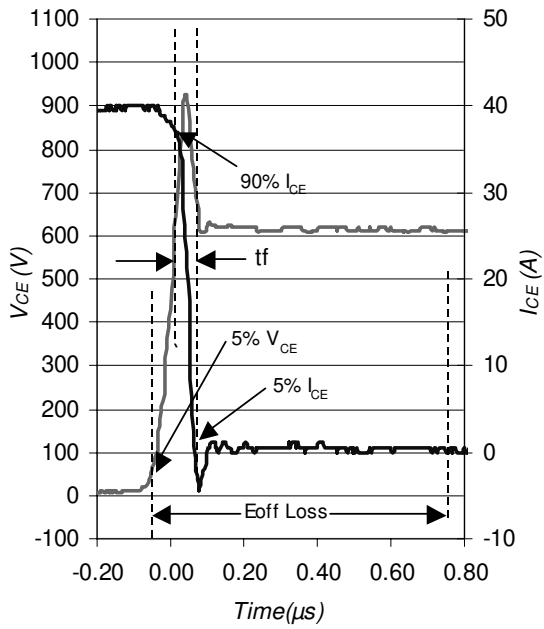

Fig. WF.2 - Typ. Turn-on Loss Waveform
@ $T_j=125^\circ\text{C}$ using Fig. CT.4

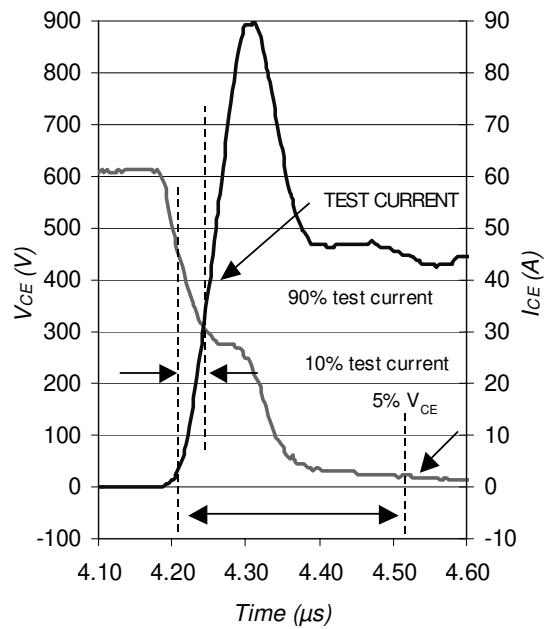
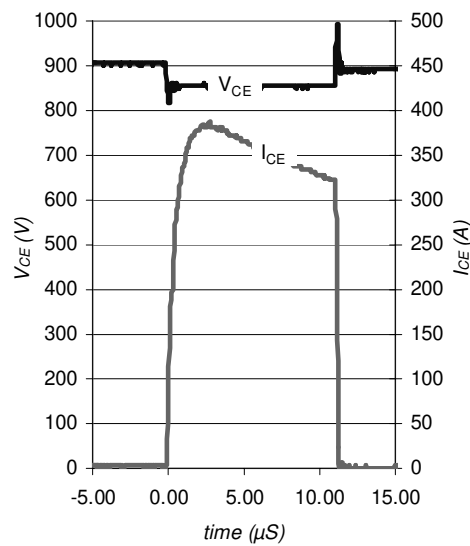

Fig. WF.3 - Typ. S.C. Waveform
@ $T_C=150^\circ\text{C}$ using Fig. CT.3



IRGPS40B120UP

Case Outline and Dimensions — Super-247

International
IR Rectifier

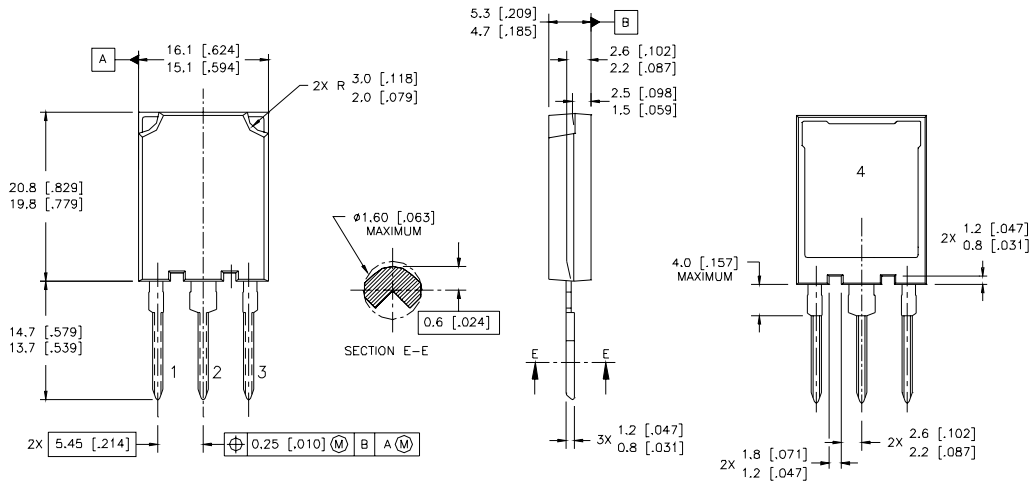

NOTES:

1. DIMENSIONS & TOLERANCING PER ASME Y14.5M-1994
2. CONTROLLING DIMENSION: MILLIMETER
3. DIMENSIONS ARE SHOWN IN MILLIMETRES [INCHES]

LEAD ASSIGNMENTS

MOSFET	IGBT
1 - GATE	1 - GATE
2 - DRAIN	2 - COLLECTOR
3 - SOURCE	3 - EMITTER
4 - DRAIN	4 - COLLECTOR

Super-247 (TO-274AA) Part Marking Information

EXAMPLE: THIS IS AN IRFPS37N50A WITH
ASSEMBLY LOT CODE 1789
ASSEMBLED ON WW 19, 1997
IN THE ASSEMBLY LINE "C"

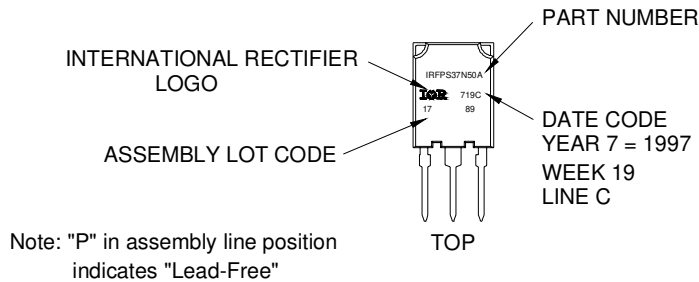

Data and specifications subject to change without notice.
This product has been designed and qualified for the industrial market.
Qualification Standards can be found on IR's Web site.

International
IR Rectifier

IR WORLD HEADQUARTERS: 233 Kansas St., El Segundo, California 90245, USA Tel: (310) 252-7105
TAC Fax: (310) 252-7903

Visit us at www.irf.com for sales contact information.03/05

www.irf.com