



Chipsmall Limited consists of a professional team with an average of over 10 year of expertise in the distribution of electronic components. Based in Hongkong, we have already established firm and mutual-benefit business relationships with customers from,Europe,America and south Asia,supplying obsolete and hard-to-find components to meet their specific needs.

With the principle of "Quality Parts,Customers Priority,Honest Operation,and Considerate Service",our business mainly focus on the distribution of electronic components. Line cards we deal with include Microchip,ALPS,ROHM,Xilinx,Pulse,ON,Everlight and Freescale. Main products comprise IC,Modules,Potentiometer,IC Socket,Relay,Connector.Our parts cover such applications as commercial,industrial, and automotives areas.

We are looking forward to setting up business relationship with you and hope to provide you with the best service and solution. Let us make a better world for our industry!



Contact us

Tel: +86-755-8981 8866 Fax: +86-755-8427 6832

Email & Skype: info@chipsmall.com Web: www.chipsmall.com

Address: A1208, Overseas Decoration Building, #122 Zhenhua RD., Futian, Shenzhen, China



Dual Channel Sensorless Motor Control IC for Appliances

Features

- **MCE™ (Motion Control Engine) - Hardware based computation engine for high efficiency sinusoidal sensorless control of permanent magnet AC motor**
- **Integrated Power Factor Correction control**
- **Supports both interior and surface permanent magnet motors**
- **Built-in hardware peripheral for single shunt current feedback reconstruction**
- **No external current or voltage sensing operational amplifier required**
- **Dual channel three/two-phase Space Vector PWM**
- **Two-channel analog output (PWM)**
- **Embedded 8-bit high speed microcontroller (8051) for flexible I/O and man-machine control**
- **JTAG programming port for emulation/debugger**
- **Two serial communication interface (UART)**
- **I²C/SPI serial interface**
- **Watchdog timer with independent analog clock**
- **Three general purpose timers**
- **Two special timers: periodic timer, capture timer**
- **External EEPROM and internal RAM facilitate debugging and code development**
- **Pin compatible with IRMCK311, OTP-ROM version**
- **1.8V/3.3V CMOS**

Product Summary

Maximum crystal frequency	60 MHz
Maximum internal clock (SYSCLK) frequency	128 MHz
Sensorless control computation time	11 µsec typ
MCE™ computation data range	16 bit signed
Program RAM loaded from external EEPROM	48K bytes
Data RAM	8K bytes
GateKill latency (digital filtered)	2 µsec
PWM carrier frequency counter	16 bits/ SYSCLK
A/D input channels	6
A/D converter resolution	12 bits
A/D converter conversion speed	2 µsec
8051 instruction execution speed	2 SYSCLK
Analog output (PWM) resolution	8 bits
UART baud rate (typ)	57.6K bps
Number of I/O (max)	14
Package (lead-free)	QFP64

Description

IRMCF311 is a high performance RAM based motion control IC designed primarily for appliance applications. IRMCF311 is designed to achieve low cost and high performance control solutions for advanced inverterized appliance motor control. IRMCF311 contains two computation engines. One is Motion Control Engine (MCE™) for sensorless control of permanent magnet motors; the other is an 8-bit high-speed microcontroller (8051). Both computation engines are integrated into one monolithic chip. The MCE™ contains a collection of control elements such as Proportional plus Integral, Vector rotator, Angle estimator, Multiply/Divide, Low loss SVPWM, Single Shunt IFB. The user can program a motion control algorithm by connecting these control elements using a graphic compiler. Key components of the sensorless control algorithms, such as the Angle Estimator, are provided as complete pre-defined control blocks implemented in hardware. A unique analog/digital circuit and algorithm to fully support single shunt current reconstruction is also provided. The 8051 microcontroller performs 2-cycle instruction execution (60MIPS at 120MHz). The MCE and 8051 microcontroller are connected via dual port RAM to process signal monitoring and command input. An advanced graphic compiler for the MCE™ is seamlessly integrated into the MATLAB/Simulink environment, while third party JTAG based emulator tools are supported for 8051 developments. IRMCF311 comes with a small QFP64 pin lead-free package.

TABLE OF CONTENTS

1	Overview.....	4
2	IRMCF311 Block Diagram and Main Functions.....	5
3	Pinout.....	7
4	Input/Output of IRMCF311	8
4.1	8051 Peripheral Interface Group	8
4.2	Motion Peripheral Interface Group	9
4.3	Analog Interface Group.....	10
4.4	Power Interface Group	11
4.5	Test Interface Group.....	11
5	Application Connections	12
6	DC Characteristics	13
6.1	Absolute Maximum Ratings	13
6.2	System Clock Frequency and Power Consumption	13
6.3	Digital I/O DC Characteristics	14
6.4	PLL and Oscillator DC Characteristics	15
6.5	Analog I/O DC Characteristics	15
6.6	Analog I/O DC Characteristics	16
6.7	Under Voltage Lockout DC Characteristics.....	17
6.8	CMEXT and AREF Characteristics	17
7	AC Characteristics	18
7.1	PLL AC Characteristics	18
7.2	Analog to Digital Converter AC Characteristics.....	19
7.3	Op amp AC Characteristics.....	20
7.4	Op Amp AC Characteristics.....	20
7.5	SYNC to SVPWM and A/D Conversion AC Timing.....	21
7.6	GATEKILL to SVPWM AC Timing	22
7.7	Interrupt AC Timing	22
7.8	I ² C AC Timing	23
7.9	SPI AC Timing.....	24
7.9.1	SPI Write AC timing	24
7.9.2	SPI Read AC Timing.....	25
7.10	UART AC Timing	26
7.11	CAPTURE Input AC Timing	27
7.12	JTAG AC Timing	28
8	I/O Structure	29
9	Pin List.....	32
10	Package Dimensions.....	35
11	Part Marking Information.....	36

TABLE OF FIGURES

Figure 1.	Typical Application Block Diagram Using IRMCF311	4
Figure 2.	IRMCF311 Internal Block Diagram.....	5
Figure 3.	IRMCF311 Pin Configuration.....	7
Figure 4.	Input/Output of IRMCF311	8
Figure 5.	Application Connection of IRMCF311.....	12
Figure 6.	Clock Frequency vs. Power Consumption	13
Figure 7	All digital I/O and PWM outputs	29
Figure 8	RESET, GATEKILL I/O.....	29
Figure 9	Analog input.....	30
Figure 10	Analog operational amplifier output and AREF I/O structure.....	30
Figure 11	VSS, AVSS and PLLVSS pin structure.....	30
Figure 12	VDD1, VDD2, AVDD and PLLVDD pin structure	31
Figure 13	XTAL0/XTAL1 pins structure.....	31

TABLE OF TABLES

Table 1.	Absolute Maximum Ratings.....	13
Table 2.	System Clock Frequency	13
Table 3.	Digital I/O DC Characteristics	14
Table 4.	PLL DC Characteristics.....	15
Table 5.	Analog I/O DC Characteristics.....	15
Table 6.	Analog I/O DC Characteristics.....	16
Table 7.	UVcc DC Characteristics	17
Table 8.	CMEXT and AREF DC Characteristics.....	17
Table 9.	PLL AC Characteristics.....	18
Table 10.	A/D Converter AC Characteristics.....	19
Table 11.	Current Sensing OP Amp AC Characteristics.....	20
Table 12.	Voltage sensing OP Amp AC Characteristics	20
Table 13.	SYNC AC Characteristics	21
Table 14.	GATEKILL to SVPWM AC Timing	22
Table 15.	Interrupt AC Timing.....	22
Table 16.	I ² C AC Timing	23
Table 17.	SPI Write AC Timing.....	24
Table 18.	SPI Read AC Timing.....	25
Table 19.	UART AC Timing.....	26
Table 20.	CAPTURE AC Timing	27
Table 21.	JTAG AC Timing.....	28
Table 22.	Pin List	34

Overview

IRMCF311 is a new International Rectifier integrated circuit device primarily designed as a one-chip solution for complete inverter controlled air conditioner motor control applications. Unlike a traditional microcontroller or DSP, the IRMCF311 provides a built-in closed loop sensorless control algorithm using the unique Motion Control Engine (MCE™) for permanent magnet motors. The MCE™ consists of a collection of control elements, motion peripherals, a dedicated motion control sequencer and dual port RAM to map internal signal nodes. IRMCF311 also employs a unique single shunt current reconstruction circuit to eliminate additional analog/digital circuitry and enables a direct shunt resistor interface to the IC. Motion control programming is achieved using a dedicated graphical compiler integrated into the MATLAB/Simulink™ development environment. Sequencing, user interface, host communication, and upper layer control tasks can be implemented in the 8051 high-speed 8-bit microcontroller. The 8051 microcontroller is equipped with a JTAG port to facilitate emulation and debugging tools. Figure 1 shows a typical application schematics using IRMCF311.

IRMCF311 is intended for development purpose and contains 48K bytes of RAM, which can be loaded from external EEPROM for 8051 program execution. For high volume production, IRMCK311 contains OTP ROM in place of program RAM to reduce the cost. Both IRMCF311 and IRMCK311 come in the same 64-pin QFP package with identical pin configuration to facilitate PC board layout and transition to mass production

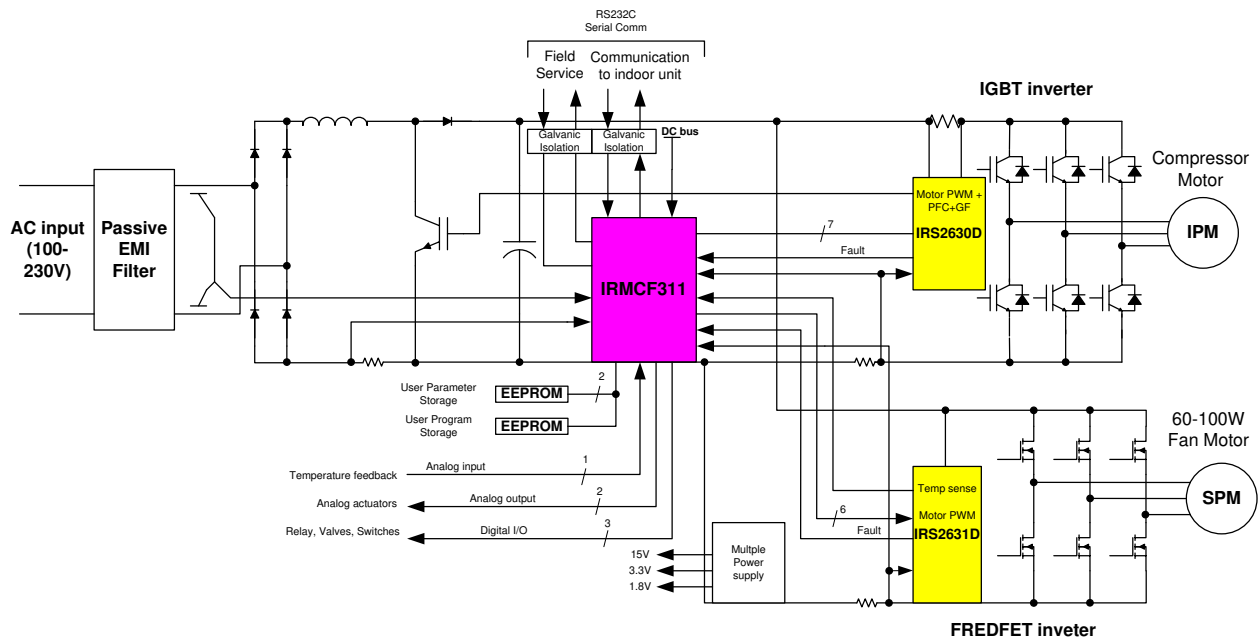

Figure 1. Typical Application Block Diagram Using IRMCF311

2 IRMCF311 Block Diagram and Main Functions

IRMCF311 block diagram is shown in Figure 2.

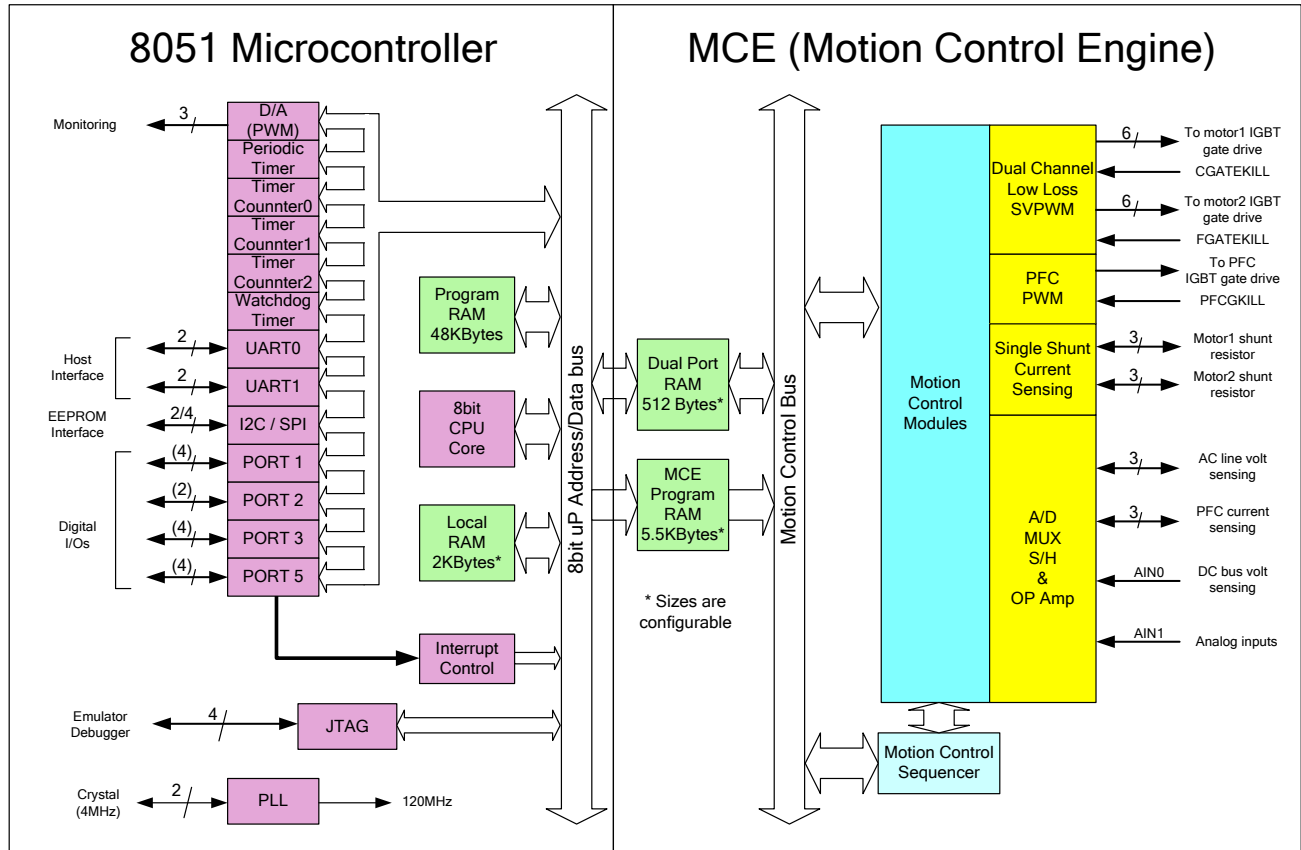

Figure 2. IRMCF311 Internal Block Diagram

IRMCF311 contains the following functions for sensorless AC motor control applications:

- Motion Control Engine (MCE™)
 - Proportional plus Integral block
 - Low pass filter
 - Differentiator and lag (high pass filter)
 - Ramp
 - Limit
 - Angle estimate (sensorless control)
 - Inverse Clark transformation
 - Vector rotator
 - Bit latch

- Peak detect
 - Transition
 - Multiply-divide (signed and unsigned)
 - Divide (signed and unsigned)
 - Adder
 - Subtractor
 - Comparator
 - Counter
 - Accumulator
 - Switch
 - Shift
 - ATAN (arc tangent)
 - Function block (any curve fitting, nonlinear function)
 - 16-bit wide Logic operations (AND, OR, XOR, NOT, NEGATE)
 - MCETM program and data memory (6K byte).^{Note 1}
 - MCETM control sequencer
- 8051 microcontroller
 - Three 16-bit timer
 - 16-bit periodic timer
 - 16-bit analog watchdog timer
 - 16-bit capture timer
 - Up to 14 discrete I/Os
 - Six-channel 12-bit A/D
 - Four buffered channels (0 – 1.2V input)
 - Two unbuffered channels (0 – 1.2V input)
 - JTAG port (4 pins)
 - Up to two channels of analog output (8-bit PWM)
 - Two UART
 - I²C/SPI port
 - 48K byte program RAM loaded from external EEPROM
 - 2K byte data RAM.^{Note 1}

Note 1: Total size of RAM is 8K byte including MCE program, MCE data, and 8051 data. Different sizes can be allocated depending on applications.

3 Pinout

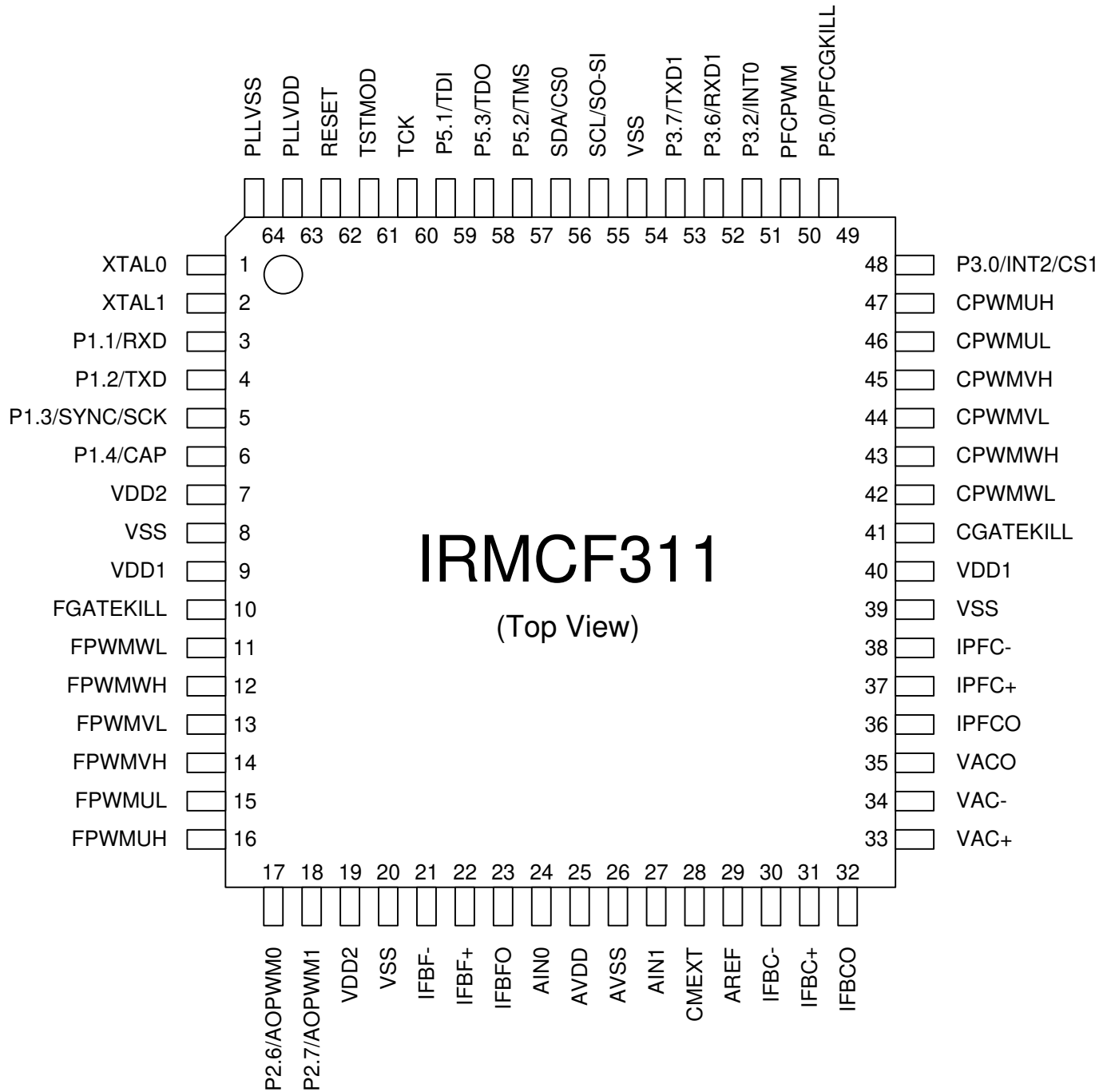

Figure 3. IRMCF311 Pin Configuration

4 Input/Output of IRMCF311

All I/O signals of IRMCF311 are shown in Figure 4. All I/O pins are 3.3V logic interface except A/D interface pins.

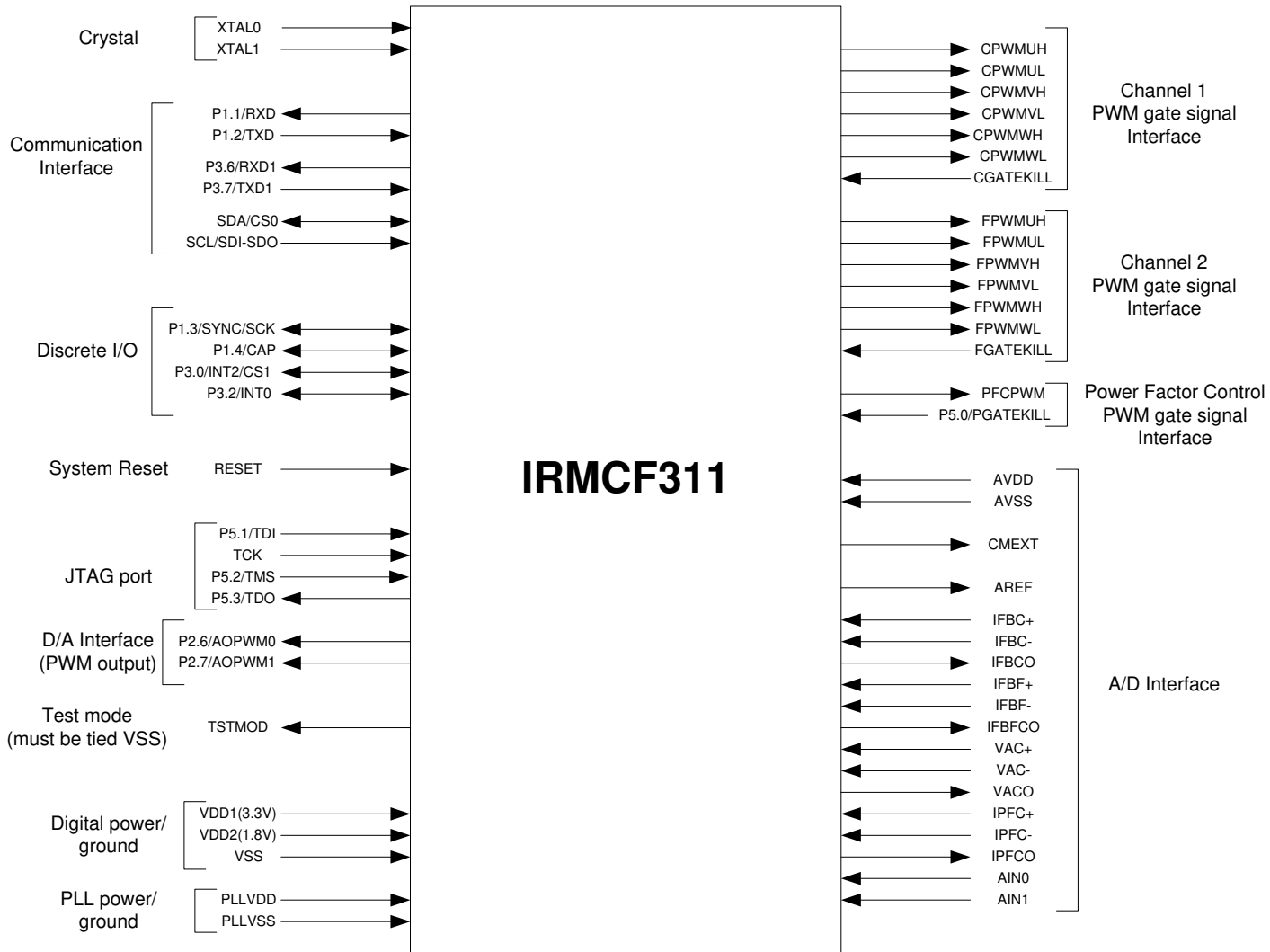

Figure 4. Input/Output of IRMCF311

4.1 8051 Peripheral Interface Group

UART Interface

P1.1/RXD Input, Receive data to IRMCF311

P1.2/TXD	Output, Transmit data from IRMCF311
P3.6/RXD1	Input, 2 nd channel Receive data to IRMCF311
P3.7/TXD1	Output, 2 nd channel Transmit data from IRMCF311

Discrete I/O Interface

P1.3/SYNC/SCK	Input/output port 1.3, can be configured as SYNC output or SPI clock, needs to be pulled up to VDD1 in order to boot from I ² C EEPROM
P1.4/CAP	Input/output port 1.4, can be configured as Capture Timer input
P3.0/INT2/CS1	Input/output port 3.0, can be configured as external interrupt 2 or SPI chip select 1
P3.2/INT0	Input/output port 3.2, can be configured as external interrupt 0

Analog output Interface

P2.6/AOPWM0	Output, PWM output 0, 8-bit resolution, configurable carrier frequency
P2.7/AOPWM1	Output, PWM output 1, 8-bit resolution, configurable carrier frequency

Crystal Interface

XTAL0	Input, connected to crystal
XTAL1	Output, connected to crystal

Reset Interface

RESET	Inout, system reset, needs to be pulled up to VDD1 but doesn't require external RC time constant
-------	--

I²C/SPI Interface

SCL/SO-SI	Output, I ² C clock output or SPI data
SDA/CS0	Input/output, I ² C data line or SPI chip select 0
P3.0/INT2/CS1	Input/output, INT2 or SPI chip select 1
P1.3/SYNC/SCK	Input/output, SYNC output or SPI clock, needs to be pulled up to VDD1 in order boot from I ² C EEPROM

4.2 Motion Peripheral Interface Group

PWM

CPWMUH	Output, motor 1 PWM phase U high side gate signal
CPWMUL	Output, motor 1 PWM phase U low side gate signal
CPWMVH	Output, motor 1 PWM phase V high side gate signal
CPWMVL	Output, motor 1 PWM phase V low side gate signal
CPWMWH	Output, motor 1 PWM phase W high side gate signal

CPWMWL	Output, motor 1 PWM phase W low side gate signal
FPWMUH	Output, motor 2 PWM phase U high side gate signal
FPWMUL	Output, motor 2 PWM phase U low side gate signal
FPWMVH	Output, motor 2 PWM phase V high side gate signal
FPWMVL	Output, motor 2 PWM phase V low side gate signal
FPWMWH	Output, motor 2 PWM phase W high side gate signal
FPWMWL	Output, motor 2 PWM phase W low side gate signal
PFCPWM	Output, PFC PWM

Fault

CGATEKILL	Input, upon assertion, this negates all six PWM signals for motor 1, programmable logic sense
P5.0/PFCGKILL	Input, upon assertion, this negates PFCPWM signal, programmable logic sense, can be configured as discrete I/O in which case CGATEKILL negates PFCPWM
FGATEKILL	Input, upon assertion, this negates all six PWM signals for motor 2, programmable logic sense

4.3 Analog Interface Group

AVDD	Analog power (1.8V)
AVSS	Analog power return
AREF	Buffered 0.6V output
CMEXT	Unbuffered 0.6V, input to the AREF buffer, capacitor needs to be connected.
IFBC+	Input, Operational amplifier positive input for shunt resistor current sensing of motor 1
IFBC-	Input, Operational amplifier negative input for shunt resistor current sensing of motor 1
IFBCO	Output, Operational amplifier output for shunt resistor current sensing of motor 1
IFBF+	Input, Operational amplifier positive input for shunt resistor current sensing of motor 2
IFBF-	Input, Operational amplifier negative input for shunt resistor current sensing of motor 2
IFBFO	Output, Operational amplifier output for shunt resistor current sensing of motor 2
IPFC+	Input, Operational amplifier positive input for PFC current sensing
IPFC-	Input, Operational amplifier negative input for PFC current sensing
IPFO	Output, Operational amplifier output for PFC current sensing
VAC+	Input, Operational amplifier positive input for PFC AC voltage sensing
VAC-	Input, Operational amplifier negative input for PFC AC voltage sensing
VACO	Output, Operational amplifier output for PFC AC voltage sensing

AIN0	Input, Analog input channel 0 (0 - 1.2V), typically configured for DC bus voltage input
AIN1	Input, Analog input channel 1 (0 - 1.2V), needs to be pulled down to AVSS if unused

4.4 Power Interface Group

VDD1	Digital power for I/O (3.3V)
VDD2	Digital power for core logic (1.8V)
VSS	Digital common
PLLVDD	PLL power (1.8V)
PLLVSS	PLL ground return

4.5 Test Interface Group

TSTMOD	Must be tied to VSS, used only for factory testing.
P5.1/TDI	Input, JTAG test data input, or programmable discrete I/O
P5.2/TMS	Input, JTAG test mode select, or programmable discrete I/O
TCK	Input, JTAG test clock
P5.3/TDO	Output, JTAG test data output, or programmable discrete I/O

5 Application Connections

Typical application connection is shown Figure 5. All components necessary to implement a complete sensorless drive control algorithm are shown connected to IRMCF311.

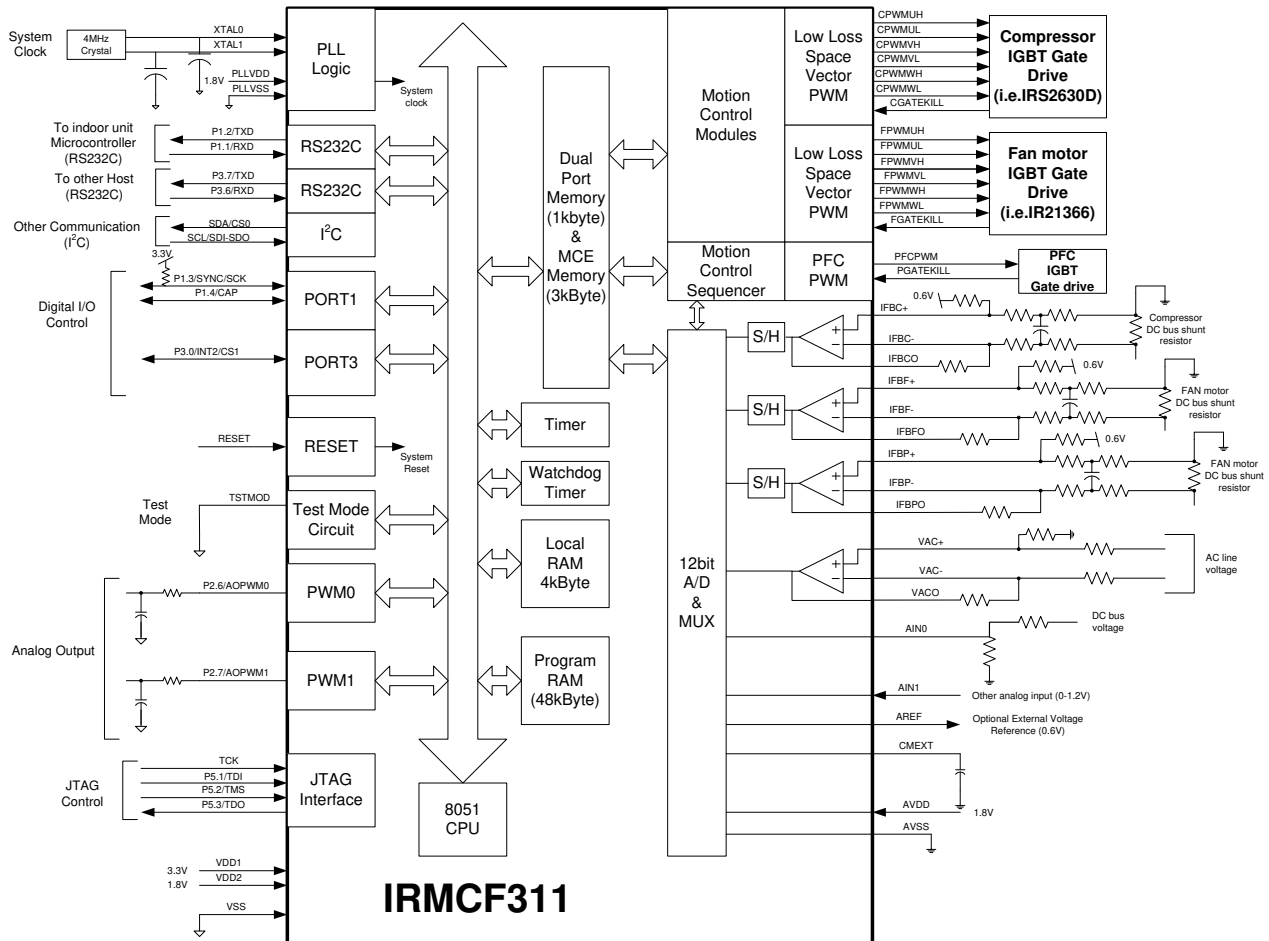

Figure 5. Application Connection of IRMCF311

6 DC Characteristics

6.1 Absolute Maximum Ratings

Symbol	Parameter	Min	Typ	Max	Condition
V _{DD1}	Supply Voltage	-0.3 V	-	3.6 V	Respect to VSS
V _{DD2}	Supply Voltage	-0.3 V	-	1.98 V	Respect to VSS
V _{IA}	Analog Input Voltage	-0.3 V	-	1.98 V	Respect to AVSS
V _{ID}	Digital Input Voltage	-0.3 V	-	3.65 V	Respect to VSS
T _A	Ambient Temperature	-40 °C	-	85 °C	
T _S	Storage Temperature	-65 °C	-	150 °C	

Table 1. Absolute Maximum Ratings

Caution: Stresses beyond those listed in “Absolute Maximum Ratings” may cause permanent damage to the device. These are stress ratings only and function of the device at these or any other conditions beyond those indicated in the operational sections of the specifications are not implied.

6.2 System Clock Frequency and Power Consumption

Symbol	Parameter	Min	Typ	Max	Unit
SYSCLK	System Clock	32	-	128	MHz

Table 2. System Clock Frequency

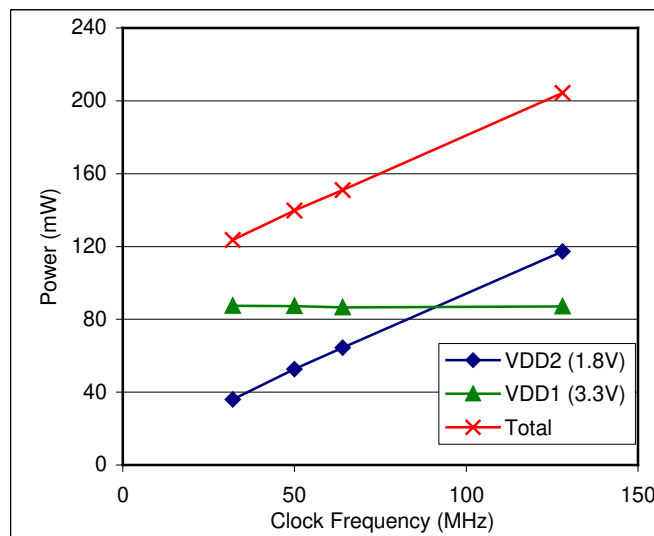

Figure 6. Clock Frequency vs. Power Consumption

6.3 Digital I/O DC Characteristics

Symbol	Parameter	Min	Typ	Max	Condition
V _{DD1}	Supply Voltage	3.0 V	3.3 V	3.6 V	Recommended
V _{DD2}	Supply Voltage	1.62 V	1.8 V	1.98 V	Recommended
V _{IL}	Input Low Voltage	-0.3 V	-	0.8 V	Recommended
V _{IH}	Input High Voltage	2.0 V		3.6 V	Recommended
C _{IN}	Input capacitance	-	3.6 pF	-	⁽¹⁾
I _L	Input leakage current		±10 nA	±1 µA	V _O = 3.3 V or 0 V
I _{OL1} ⁽²⁾	Low level output current	8.9 mA	13.2 mA	15.2 mA	V _{OL} = 0.4 V ⁽¹⁾
I _{OH1} ⁽²⁾	High level output current	12.4 mA	24.8 mA	38 mA	V _{OH} = 2.4 V ⁽¹⁾
I _{OL2} ⁽³⁾	Low level output current	17.9 mA	26.3 mA	33.4 mA	V _{OL} = 0.4 V ⁽¹⁾
I _{OH2} ⁽³⁾	High level output current	24.6 mA	49.5 mA	81 mA	V _{OH} = 2.4 V ⁽¹⁾

Table 3. Digital I/O DC Characteristics

Note:

- (1) Data guaranteed by design.
- (2) Applied to SCL/SO-SI, SDA/CS0 pins.
- (3) Applied to P1.1/RXD, P1.2/TXD, P1.3/SYNC/SCK, P1.4/CAP, P2.6/AOPWM0, P2.7/AOPWM1, P3.0/INT2/CS1, P3.2/INT0, P3.6/RXD1, P3.7/TXD1, P5.0/PFCGKILL, P5.2/TMS, P5.3/TDO, P5.1/TDI, CGATEKILL, FGATEKILL, CPWMUL, CPWMUH, CPWMVL, CPWMVH, CPWMWL, CPWMWH, FPWMUL, FPWMUH, FPWMVL, FPWMVH, FPWMWL, FPWMWH, and PFCPWM pins.

6.4 PLL and Oscillator DC Characteristics

Symbol	Parameter	Min	Typ	Max	Condition
V _{PLLVD}	Supply Voltage	1.62 V	1.8 V	1.92 V	Recommended
V _{IL OSC}	Oscillator Input Low Voltage	V _{PLLSS}	-	0.2* V _{PLLVD}	V _{PLLVD} = 1.8 V (1)
V _{IH OSC}	Oscillator Input High Voltage	0.8* V _{PLLVD}		V _{PLLVD}	V _{PLLVD} = 1.8 V (1)

Table 4. PLL DC Characteristics

Note:

(1) Data guaranteed by design.

6.5 Analog I/O DC Characteristics

- OP amps for current sensing (IFBC+, IFBC-, IFBCO, IFBF+, IFBF-, IFBFO, IPFC+, IPFC-, IPFCO)

C_{AREF} = 1nF, C_{MEXT} = 100nF. Unless specified, Ta = 25°C.

Symbol	Parameter	Min	Typ	Max	Condition
V _{AVDD}	Supply Voltage	1.71 V	1.8 V	1.89 V	Recommended
V _{OFFSET}	Input Offset Voltage	-	-	26 mV	V _{AVDD} = 1.8 V
V _I	Input Voltage Range	0 V		1.2 V	Recommended
V _{OUTSW}	OP amp output operating range	50 mV (1)	-	1.2 V	V _{AVDD} = 1.8 V
C _{IN}	Input capacitance	-	3.6 pF	-	(1)
R _{FDBK}	OP amp feedback resistor	5 kΩ	-	20 kΩ	Requested between op amp output and negative input
OP _{GAINCL}	Operating Close loop Gain	80 db	-	-	(1)
CMRR	Common Mode Rejection Ratio	-	80 db	-	(1)
I _{SRC}	Op amp output source current	-	1 mA	-	V _{OUT} = 0.6 V (1)
I _{SNK}	Op amp output sink current	-	100 μA	-	V _{OUT} = 0.6 V (1)

Table 5. Analog I/O DC Characteristics

Note:

(1) Data guaranteed by design.

6.6 Analog I/O DC Characteristics

- OP amp for voltage sensing (VAC+, VAC-, VACO)

$C_{AREF} = 1\text{nF}$, $C_{MEXT} = 100\text{nF}$. Unless specified, $T_a = 25^\circ\text{C}$.

Symbol	Parameter	Min	Typ	Max	Condition
V_{AVDD}	Supply Voltage	1.71 V	1.8 V	1.89 V	
V_{OFFSET}	Input Offset Voltage	-	-	26 mV	$V_{AVDD} = 1.8\text{ V}$
V_I	Input Voltage Range	0 V		1.2 V	
V_{OUTSW}	OP amp output operating range	50 mV ⁽¹⁾	-	1.2 V	$V_{AVDD} = 1.8\text{ V}$
C_{IN}	Input capacitance	-	3.6 pF	-	(1)
OP_{GAINCL}	Operating Close loop Gain	80 db	-	-	(1)
CMRR	Common Mode Rejection Ratio	-	80 db	-	(1)
I_{SRC}	Op amp output source current	-	5 mA	-	$V_{OUT} = 0.6\text{ V}$ (1)
I_{SNK}	Op amp output sink current	-	500 μA	-	$V_{OUT} = 0.6\text{ V}$ (1)

Table 6. Analog I/O DC Characteristics

Note:

(1) Data guaranteed by design.

6.7 Under Voltage Lockout DC Characteristics

- Based on AVDD (1.8V)

Unless specified, Ta = 25°C.

Symbol	Parameter	Min	Typ	Max	Condition
UV _{CC+}	UVcc positive going Threshold	1.53 V	1.66 V	1.71 V	V _{DD1} = 3.3 V
UV _{CC-}	UVcc negative going Threshold	1.52 V	1.62 V	1.71 V	V _{DD1} = 3.3 V
UV _{CCH}	UVcc Hysteresys	-	40 mV	-	

Table 7. UVcc DC Characteristics

6.8 CMEXT and AREF Characteristics

C_{AREF} = 1nF, C_{CMEXT} = 100nF. Unless specified, Ta = 25°C.

Symbol	Parameter	Min	Typ	Max	Condition
V _{CM}	CMEXT voltage	495 mV	600 mV	700 mV	V _{AVDD} = 1.8 V
V _{AREF}	Buffer Output Voltage	495 mV	600 mV	700 mV	V _{AVDD} = 1.8 V
ΔV _o	Load regulation (V _{DC} -0.6)	-	1 mV	-	(1)
PSRR	Power Supply Rejection Ratio	-	75 db	-	(1)

Table 8. CMEXT and AREF DC Characteristics

Note:

(1) Data guaranteed by design.

7 AC Characteristics

7.1 PLL AC Characteristics

Symbol	Parameter	Min	Typ	Max	Condition
F _{CLKIN}	Crystal input frequency	3.2 MHz	4 MHz	60 MHz	⁽¹⁾ (see figure below)
F _{PLL}	Internal clock frequency	32 MHz	50 MHz	128 MHz	⁽¹⁾
F _{LWPW}	Sleep mode output frequency	F _{CLKIN} ÷ 256	-	-	⁽¹⁾
J _S	Short time jitter	-	200 psec	-	⁽¹⁾
D	Duty cycle	-	50 %	-	⁽¹⁾
T _{LOCK}	PLL lock time	-	-	500 μsec	⁽¹⁾

Table 9. PLL AC Characteristics

Note:

(1) Data guaranteed by design.

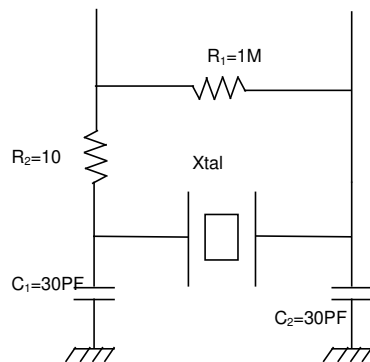

7.2 Analog to Digital Converter AC Characteristics

Unless specified, $T_a = 25^\circ\text{C}$.

Symbol	Parameter	Min	Typ	Max	Condition
T_{CONV}	Conversion time	-	-	2.05 μsec	(1)
T_{HOLD}	Sample/Hold maximum hold time	-	-	10 μsec	Voltage droop \leq 15 LSB (see figure below)

Table 10. A/D Converter AC Characteristics

Note:

(1) Data guaranteed by design.

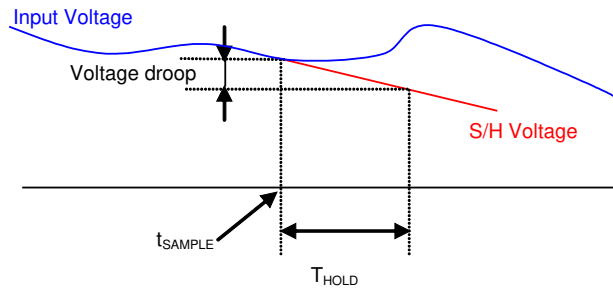

7.3 Op amp AC Characteristics

- OP amps for current sensing (IFBC+, IFBC-, IFBCO, IFBF+, IFBF-, IFBFO, IPFC+, IPFC-, IPFCO)

Unless specified, Ta = 25°C.

Symbol	Parameter	Min	Typ	Max	Condition
OP _{SR}	OP amp slew rate	-	10 V/μsec	-	V _{AVDD} = 1.8 V, CL = 33 pF ⁽¹⁾
OP _{IMP}	OP input impedance	-	10 ⁸ Ω	-	⁽¹⁾
T _{SET}	Settling time	-	400 ns	-	V _{AVDD} = 1.8 V, CL = 33 pF ⁽¹⁾

Table 11. Current Sensing OP Amp AC Characteristics

Note:

(1) Data guaranteed by design.

7.4 Op Amp AC Characteristics

- OP amp for voltage sensing (VAC+, VAC-, VACO)

Unless specified, Ta = 25°C.

Symbol	Parameter	Min	Typ	Max	Condition
OP _{SR}	OP amp slew rate		2.5 V/μsec	-	V _{AVDD} = 1.8 V, CL = 33 pF ⁽¹⁾
OP _{IMP}	OP input impedance	-	10 ⁸ Ω	-	⁽¹⁾
T _{SET}	Settling time		650 ns		V _{AVDD} = 1.8 V, CL = 33 pF ⁽¹⁾

Table 12. Voltage sensing OP Amp AC Characteristics

Note:

(1) Data guaranteed by design.

7.5 SYNC to SVPWM and A/D Conversion AC Timing

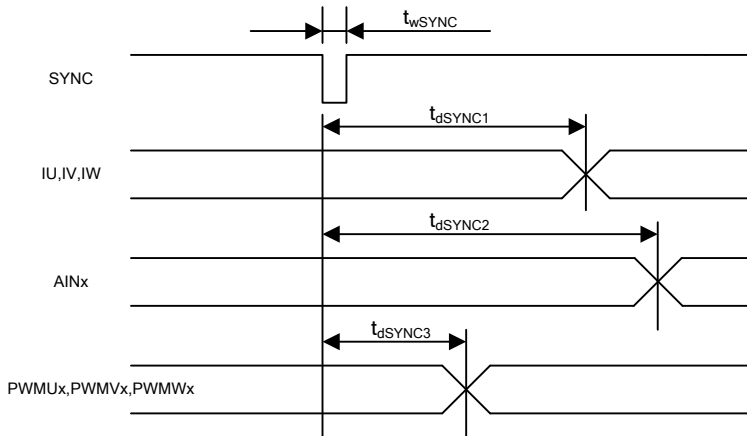

Unless specified, $T_a = 25^\circ\text{C}$.

Symbol	Parameter	Min	Typ	Max	Unit
t_{wSYNC}	SYNC pulse width	-	32	-	SYCLK
t_{dSYNC1}	SYNC to current feedback conversion time	-	-	100	SYCLK
t_{dSYNC2}	SYNC to AIN0-6 analog input conversion time	-	-	200	SYCLK ⁽¹⁾
t_{dSYNC3}	SYNC to PWM output delay time	-	-	2	SYCLK

Table 13. SYNC AC Characteristics

Note:

(1) AIN1 through AIN6 channels are converted once every 6 SYNC events

7.6 GATEKILL to SVPWM AC Timing

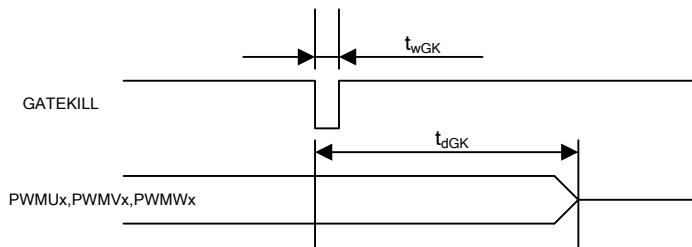

Unless specified, Ta = 25°C.

Symbol	Parameter	Min	Typ	Max	Unit
t_{wGK}	GATEKILL pulse width	32	-	-	SYSCLK
t_{dGK}	GATEKILL to PWM output delay	-	-	100	SYSCLK

Table 14. GATEKILL to SVPWM AC Timing

7.7 Interrupt AC Timing

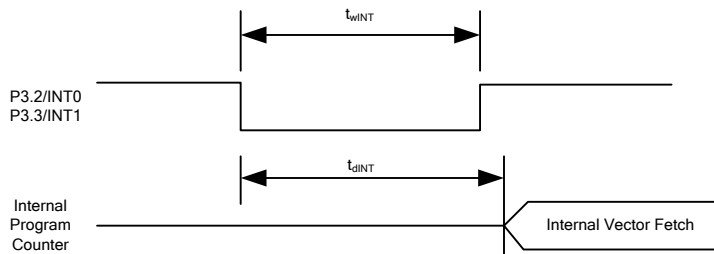

Unless specified, Ta = 25°C.

Symbol	Parameter	Min	Typ	Max	Unit
t_{wINT}	INT0, INT1 Interrupt Assertion Time	4	-	-	SYSCLK
t_{dINT}	INT0, INT1 latency	-	-	4	SYSCLK

Table 15. Interrupt AC Timing

7.8 I²C AC Timing

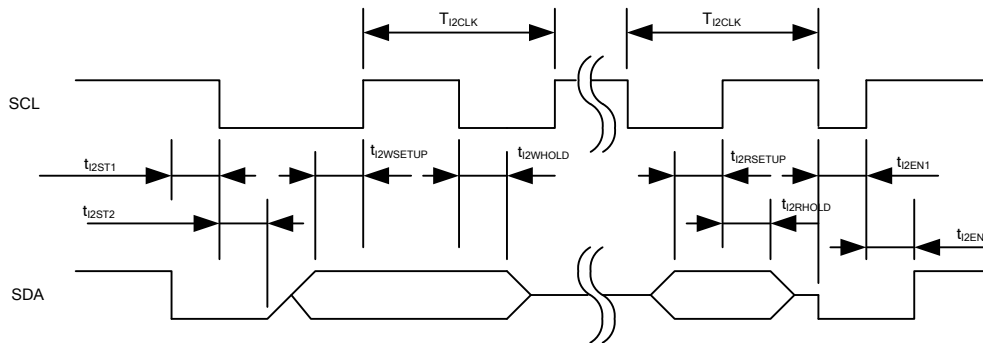

Unless specified, Ta = 25°C.

Symbol	Parameter	Min	Typ	Max	Unit
T _{I2CLK}	I ² C clock period	10	-	8192	SYSCLK
t _{I2ST1}	I ² C SDA start time	0.25	-	-	T _{I2CLK}
t _{I2ST2}	I ² C SCL start time	0.25	-	-	T _{I2CLK}
t _{I2WSETUP}	I ² C write setup time	0.25	-	-	T _{I2CLK}
t _{I2WHOLD}	I ² C write hold time	0.25	-	-	T _{I2CLK}
t _{I2RSETUP}	I ² C read setup time	I ² C filter time ⁽¹⁾	-	-	SYSCLK
t _{I2RHOLD}	I ² C read hold time	1	-	-	SYSCLK

Table 16. I²C AC Timing

Note:

- (1) I²C read setup time is determined by the programmable filter time applied to I²C communication.

7.9 SPI AC Timing

7.9.1 SPI Write AC timing

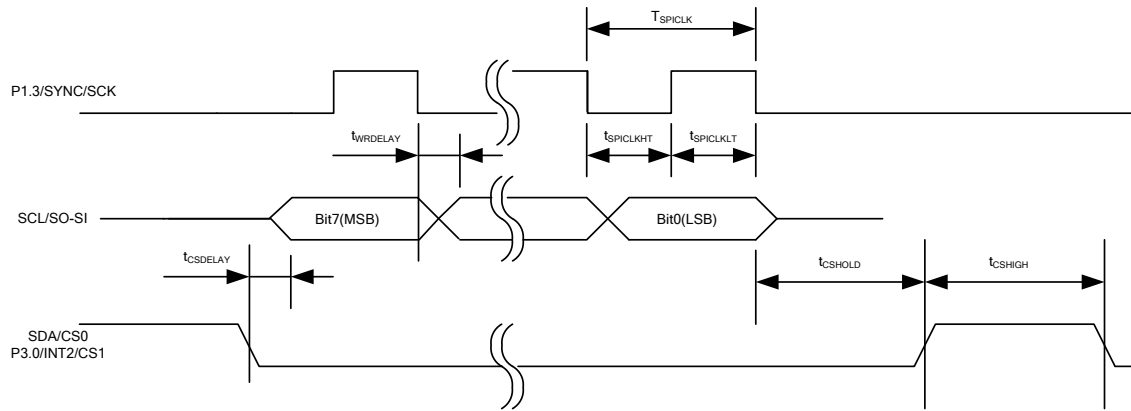

Unless specified, $T_a = 25^\circ\text{C}$.

Symbol	Parameter	Min	Typ	Max	Unit
T_{SPICLK}	SPI clock period	4	-	-	SYCLK
$t_{SPICLKHT}$	SPI clock high time	-	1/2	-	T_{SPICLK}
$t_{SPICLKLT}$	SPI clock low time	-	1/2	-	T_{SPICLK}
$t_{CSDelay}$	CS to data delay time	-	-	10	nsec
$t_{WRDELAY}$	CLK falling edge to data delay time	-	-	10	nsec
t_{CSHIGH}	CS high time between two consecutive byte transfer	1	-	-	T_{SPICLK}
t_{CSHOLD}	CS hold time	-	1	-	T_{SPICLK}

Table 17. SPI Write AC Timing

7.9.2 SPI Read AC Timing

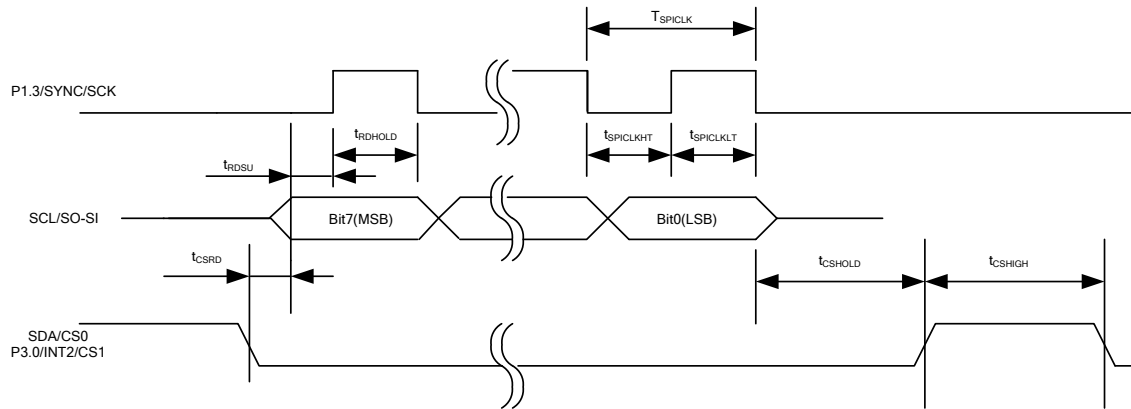

Unless specified, Ta = 25°C.

Symbol	Parameter	Min	Typ	Max	Unit
T _{SPICLK}	SPI clock period	4	-	-	SYSClk
t _{SPICLKHT}	SPI clock high time	-	1/2	-	T _{SPICLK}
t _{SPICLKLT}	SPI clock low time	-	1/2	-	T _{SPICLK}
t _{CSRd}	CS to data delay time	-	-	10	nsec
t _{RDSU}	SPI read data setup time	10	-	-	nsec
t _{RDHOLD}	SPI read data hold time	10	-	-	nsec
t _{CSHIGH}	CS high time between two consecutive byte transfer	1	-	-	T _{SPICLK}
t _{CSHOLD}	CS hold time	-	1	-	T _{SPICLK}

Table 18. SPI Read AC Timing