



Chipsmall Limited consists of a professional team with an average of over 10 year of expertise in the distribution of electronic components. Based in Hongkong, we have already established firm and mutual-benefit business relationships with customers from,Europe,America and south Asia,supplying obsolete and hard-to-find components to meet their specific needs.

With the principle of “Quality Parts,Customers Priority,Honest Operation,and Considerate Service”,our business mainly focus on the distribution of electronic components. Line cards we deal with include Microchip,ALPS,ROHM,Xilinx,Pulse,ON,Everlight and Freescale. Main products comprise IC,Modules,Potentiometer,IC Socket,Relay,Connector.Our parts cover such applications as commercial,industrial, and automotives areas.

We are looking forward to setting up business relationship with you and hope to provide you with the best service and solution. Let us make a better world for our industry!



## Contact us

Tel: +86-755-8981 8866 Fax: +86-755-8427 6832

Email & Skype: info@chipsmall.com Web: www.chipsmall.com

Address: A1208, Overseas Decoration Building, #122 Zhenhua RD., Futian, Shenzhen, China



## Sensorless Motor Control IC for Appliances

### Features

- **MCE™ (Motion Control Engine) - Hardware based computation engine for high efficiency sinusoidal sensorless control of permanent magnet AC motor**
- **Supports both interior and surface permanent magnet motors**
- **Built-in hardware peripheral for single shunt current feedback reconstruction**
- **No external current or voltage sensing operational amplifier required**
- **Three/two-phase Space Vector PWM**
- **Three-channel analog output (PWM)**
- **Embedded 8-bit high speed microcontroller (8051) for flexible I/O and man-machine control**
- **JTAG programming port for emulation/debugger**
- **Serial communication interface (UART)**
- **I<sup>2</sup>C/SPI serial interface**
- **Watchdog timer with independent analog clock**
- **Three general purpose timers/counters**
- **Two special timers: periodic timer, capture timer**
- **External EEPROM and internal RAM facilitate debugging and code development**
- **Pin compatible with IRMCK341, OTP-ROM version**
- **1.8V/3.3V CMOS**

### Product Summary

Maximum crystal frequency	60 MHz
Maximum internal clock (SYSCLK) frequency	128 MHz
Sensorless control computation time	11 µsec typ
MCE™ computation data range	16 bit signed
Program RAM loaded from external EEPROM	48K bytes
Data RAM	8K bytes
GateKill latency (digital filtered)	2 µsec
PWM carrier frequency counter	16 bits/ SYSCLK
A/D input channels	8
A/D converter resolution	12 bits
A/D converter conversion speed	2 µsec
8051 instruction execution speed	2 SYSCLK
Analog output (PWM) resolution	8 bits
UART baud rate (typ)	57.6K bps
Number of I/O (max)	24
Package (lead-free)	QFP64

### Description

IRMCF341 is a high performance RAM based motion control IC designed primarily for appliance applications. IRMCF341 is designed to achieve low cost and high performance control solutions for advanced inverterized appliance motor control. IRMCF341 contains two computation engines. One is Motion Control Engine (MCE™) for sensorless control of permanent magnet motors; the other is an 8-bit high-speed microcontroller (8051). Both computation engines are integrated into one monolithic chip. The MCE™ contains a collection of control elements such as Proportional plus Integral, Vector rotator, Angle estimator, Multiply/Divide, Low loss SVPWM, Single Shunt IFB. The user can program a motion control algorithm by connecting these control elements using a graphic compiler. Key components of the sensorless control algorithms, such as the Angle Estimator, are provided as complete pre-defined control blocks implemented in hardware. A unique analog/digital circuit and algorithm to fully support single shunt current reconstruction is also provided. The 8051 microcontroller performs 2-cycle instruction execution (60MIPS at 120MHz). The MCE and 8051 microcontroller are connected via dual port RAM to process signal monitoring and command input. An advanced graphic compiler for the MCE™ is seamlessly integrated into the MATLAB/Simulink environment, while third party JTAG based emulator tools are supported for 8051 developments. IRMCF341 comes with a small QFP64 pin lead-free package.

## TABLE OF CONTENTS

1	Overview .....	4
2	IRMCF341 Block Diagram and Main Functions .....	5
3	Pinout .....	7
4	Input/Output of IRMCF341 .....	8
4.1	8051 Peripheral Interface Group .....	8
4.2	Motion Peripheral Interface Group .....	10
4.3	Analog Interface Group .....	10
4.4	Power Interface Group .....	11
4.5	Test Interface Group .....	11
5	Application Connections .....	12
6	DC Characteristics .....	13
6.1	Absolute Maximum Ratings .....	13
6.2	System Clock Frequency and Power Consumption .....	13
6.3	Digital I/O DC Characteristics .....	14
6.4	PLL and Oscillator DC characteristics .....	15
6.5	Analog I/O DC Characteristics .....	15
6.6	Under Voltage Lockout DC characteristics .....	16
6.7	CMEXT and AREF Characteristics .....	16
7	AC Characteristics .....	17
7.1	PLL AC Characteristics .....	17
7.2	Analog to Digital Converter AC Characteristics .....	18
7.3	Op amp AC Characteristics .....	19
7.4	SYNC to SVPWM and A/D Conversion AC Timing .....	20
7.5	GATEKILL to SVPWM AC Timing .....	21
7.6	Interrupt AC Timing .....	21
7.7	I <sup>2</sup> C AC Timing .....	22
7.8	SPI AC Timing .....	23
7.8.1	SPI Write AC timing .....	23
7.8.2	SPI Read AC Timing .....	24
7.9	UART AC Timing .....	25
7.10	CAPTURE Input AC Timing .....	26
7.11	JTAG AC Timing .....	27
8	Pin List .....	28
9	Package Dimensions .....	31
10	Part Marking Information .....	32

## TABLE OF FIGURES

Figure 1. Typical Application Block Diagram Using IRMCF341 .....	4
Figure 2. IRMCF341 Internal Block Diagram .....	5
Figure 3. IRMCF341 Pin Configuration .....	7
Figure 4. Input/Output of IRMCF341 .....	8
Figure 5. Application Connection of IRMCF341 .....	12
Figure 6. Clock Frequency vs. Power Consumption .....	13

## TABLE OF TABLES

Table 1. Absolute Maximum Ratings .....	13
Table 2. System Clock Frequency .....	13
Table 3. Digital I/O DC Characteristics .....	14
Table 4. PLL DC Characteristics .....	15
Table 5. Analog I/O DC Characteristics .....	15
Table 6. UVcc DC Characteristics .....	16
Table 7. CMEXT and AREF DC Characteristics .....	16
Table 8. PLL AC Characteristics .....	17
Table 9. A/D Converter AC Characteristics .....	18
Table 10. Current Sensing OP Amp AC Characteristics .....	19
Table 11. SYNC AC Characteristics .....	20
Table 12. GATEKILL to SVPWM AC Timing .....	21
Table 13. Interrupt AC Timing .....	21
Table 14. I <sup>2</sup> C AC Timing .....	22
Table 15. SPI Write AC Timing .....	23
Table 16. SPI Read AC Timing .....	24
Table 17. UART AC Timing .....	25
Table 18. CAPTURE AC Timing .....	26
Table 19. JTAG AC Timing .....	27
Table 20. Pin List .....	30

# 1 Overview

IRMCF341 is a new International Rectifier integrated circuit device primarily designed as a one-chip solution for complete inverter controlled appliance motor control applications. Unlike a traditional microcontroller or DSP, the IRMCF341 provides a built-in closed loop sensorless control algorithm using the unique Motion Control Engine (MCE™) for permanent magnet motors. The MCE™ consists of a collection of control elements, motion peripherals, a dedicated motion control sequencer and dual port RAM to map internal signal nodes. IRMCF341 also employs a unique single shunt current reconstruction circuit to eliminate additional analog/digital circuitry and enables a direct shunt resistor interface to the IC. Motion control programming is achieved using a dedicated graphical compiler integrated into the MATLAB/Simulink™ development environment. Sequencing, user interface, host communication, and upper layer control tasks can be implemented in the 8051 high-speed 8-bit microcontroller. The 8051 microcontroller is equipped with a JTAG port to facilitate emulation and debugging tools. Figure 1 shows a typical application schematic using the IRMCF341.

IRMCF341 is intended for development purpose and contains 48K bytes of RAM, which can be loaded from external EEPROM for 8051 program execution. For high volume production, IRMCK341 contains OTP ROM in place of program RAM to reduce the cost. Both IRMCF341 and IRMCK341 come in the same 64-pin QFP package with identical pin configuration to facilitate PC board layout and transition to mass production

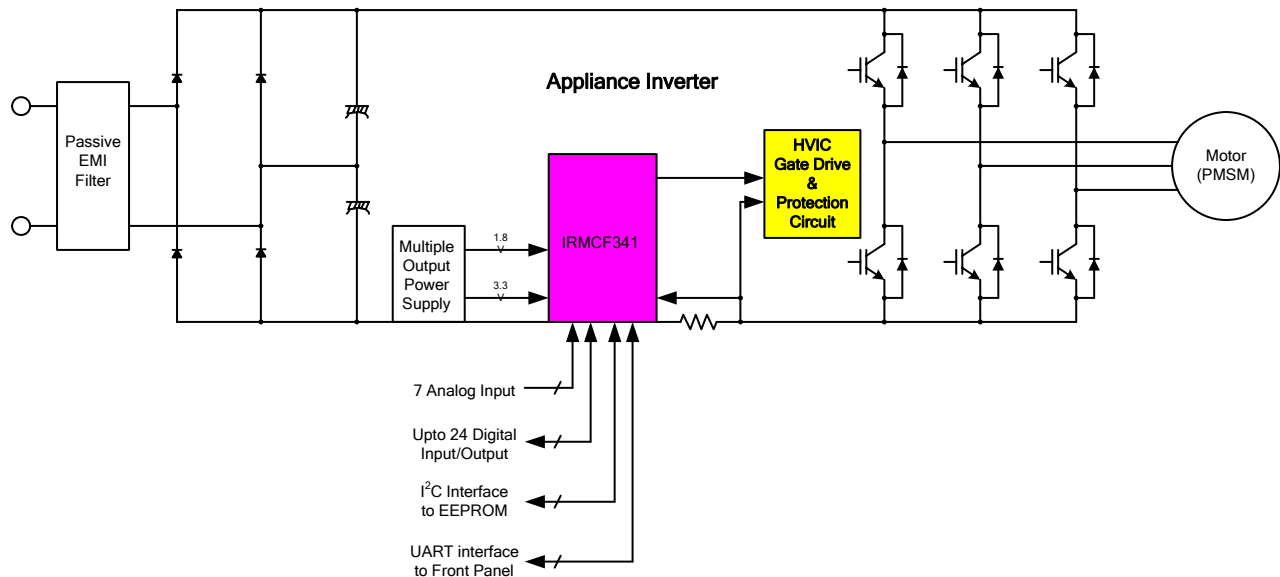

**Figure 1. Typical Application Block Diagram Using IRMCF341**

## 2 IRMCF341 Block Diagram and Main Functions

IRMCF341 block diagram is shown in Figure 2.

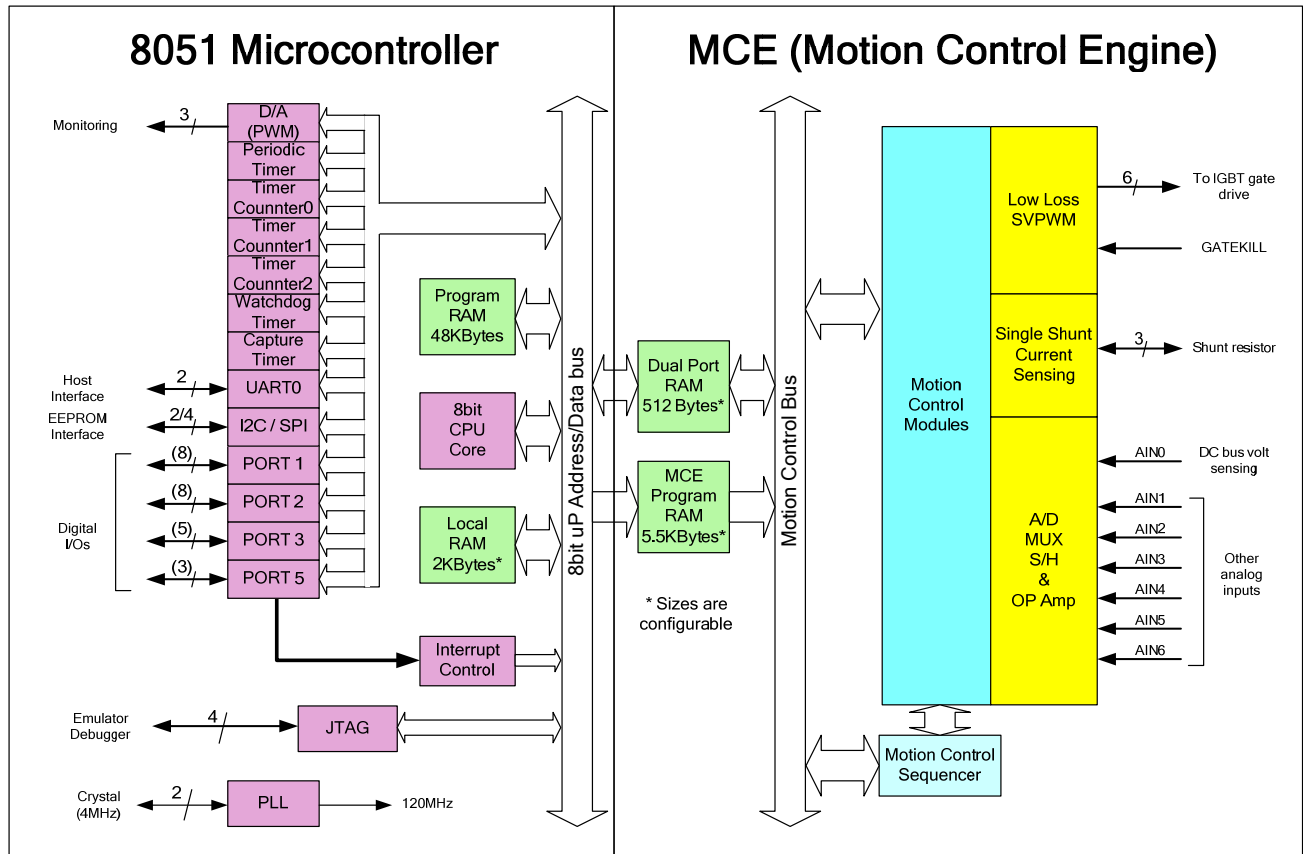

Figure 2. IRMCF341 Internal Block Diagram

IRMCF341 contains the following functions for sensorless AC motor control applications:

- Motion Control Engine (MCE™)
  - Proportional plus Integral block
  - Low pass filter
  - Differentiator and lag (high pass filter)
  - Ramp
  - Limit
  - Angle estimate (sensorless control)
  - Inverse Clark transformation
  - Vector rotator
  - Bit latch
  - Peak detect

- Transition
  - Multiply-divide (signed and unsigned)
  - Divide (signed and unsigned)
  - Adder
  - Subtractor
  - Comparator
  - Counter
  - Accumulator
  - Switch
  - Shift
  - ATAN (arc tangent)
  - Function block (any curve fitting, nonlinear function)
  - 16-bit wide Logic operations (AND, OR, XOR, NOT, NEGATE)
  - MCE™ program and data memory (6K byte). <sup>Note 1</sup>
  - MCE™ control sequencer
- 8051 microcontroller
    - Three 16-bit timer/counters
    - 16-bit periodic timer
    - 16-bit analog watchdog timer
    - 16-bit capture timer
    - Up to 24 discrete I/Os
    - Eight-channel 12-bit A/D
      - One buffered channel for current sensing (0 – 1.2V input)
      - Seven unbuffered channels (0 – 1.2V input)
    - JTAG port (4 pins)
    - Up to three channels of analog output (8-bit PWM)
    - UART
    - I<sup>2</sup>C/SPI port
    - 48K byte program RAM loaded from external EEPROM
    - 2K byte data RAM. <sup>Note 1</sup>

Note 1: Total size of RAM is 8K byte including MCE program, MCE data, and 8051 data. Different sizes can be allocated depending on applications.

### 3 Pinout

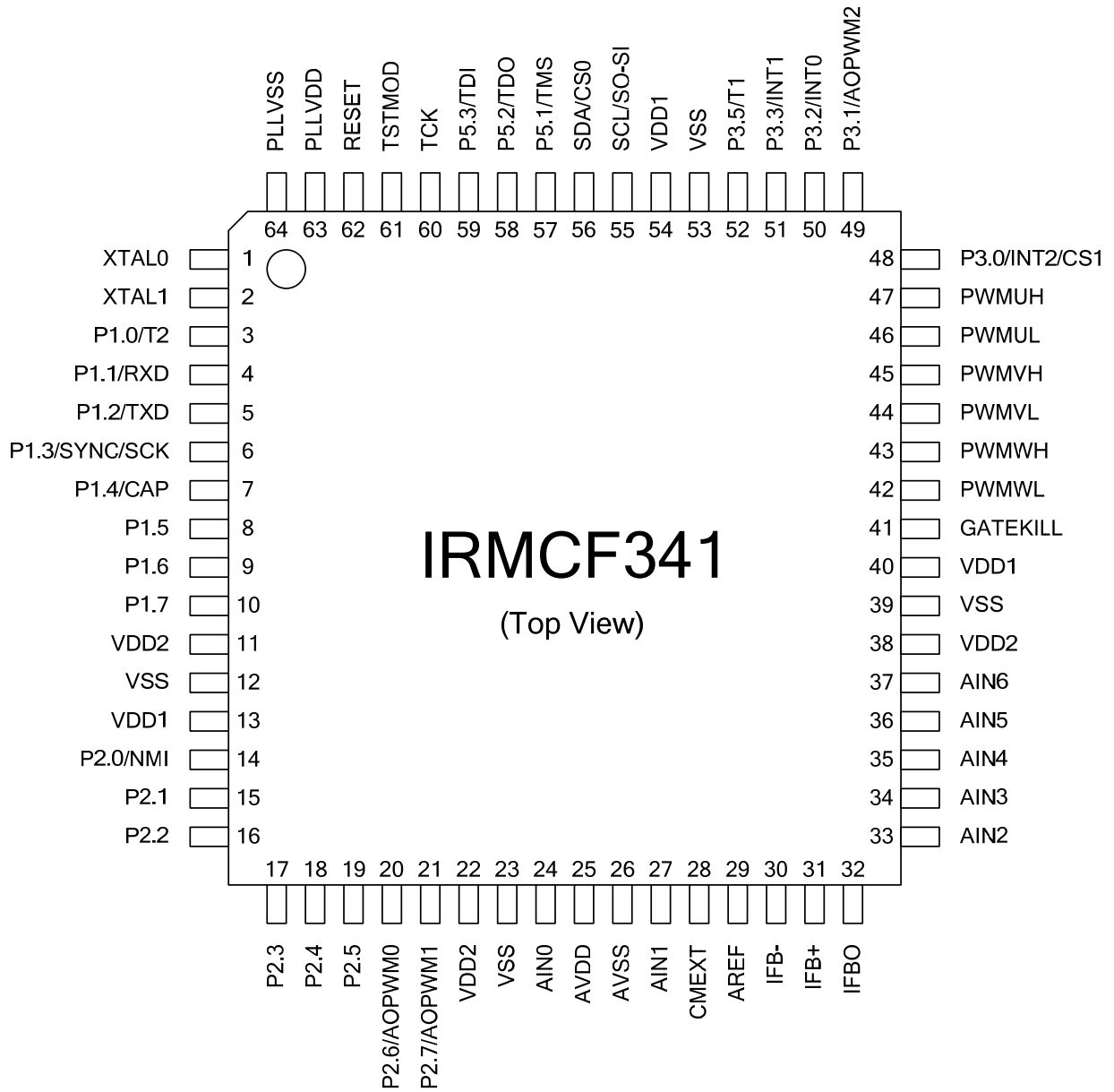

**Figure 3. IRMCF341 Pin Configuration**



## 4 Input/Output of IRMCF341

All I/O signals of IRMCF341 are shown in Figure 4. All I/O pins are 3.3V logic interface except A/D interface pins.

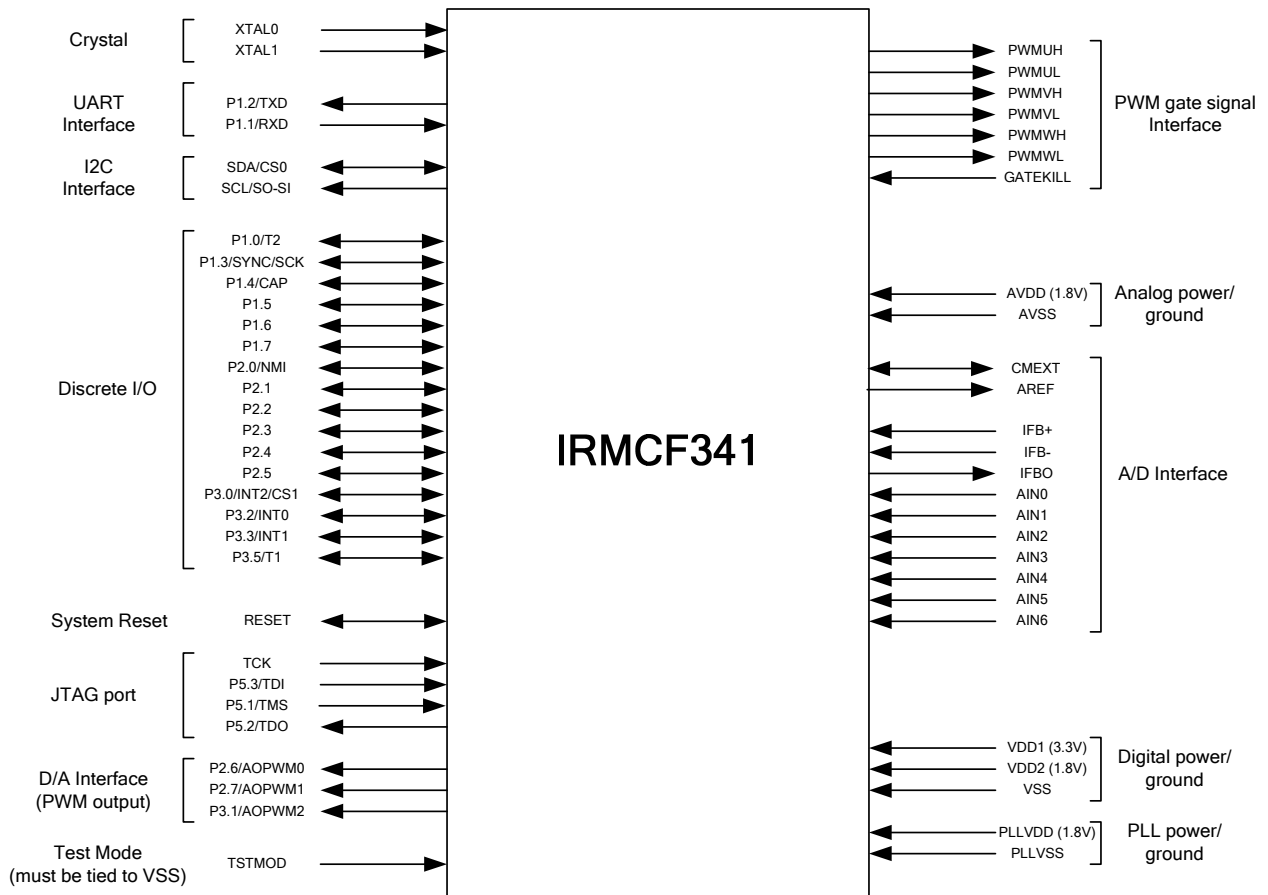

Figure 4. Input/Output of IRMCF341

### 4.1 8051 Peripheral Interface Group

#### UART Interface

TXD Output, Transmit data from IRMCF341  
RXD Input, Receive data to IRMCF341

#### Discrete I/O Interface

P1.0/T2 Input/output port 1.0, can be configured as Timer/Counter 2 input  
P1.1/RXD Input/output port 1.1, can be configured as RXD input  
P1.2/TXD Input/output port 1.2, can be configured as TXD output

P1.3/SYNC/SCK	Input/output port 1.3, can be configured as SYNC output or SPI clock output, needs to be pulled up to VDD1 in order to boot from I <sup>2</sup> C EEPROM
P1.4/CAP	Input/output port 1.4, can be configured as Capture Timer input
P1.5	Input/output port 1.5
P1.6	Input/output port 1.6
P1.7	Input/output port 1.7
P2.0/NMI	Input/output port 2.0, can be configured as non-maskable interrupt input
P2.1	Input/output port 2.1
P2.2	Input/output port 2.2
P2.3	Input/output port 2.3
P2.4	Input/output port 2.4
P2.5	Input/output port 2.5
P2.6/AOPWM0	Input/output port 2.6, can be configured as AOPWM0 output
P2.7/AOPWM1	Input/output port 2.7, can be configured as AOPWM1 output
P3.0/INT2/CS1	Input/output port 3.0, can be configured as INT2 input or SPI chip select 1
P3.1/AOPWM2	Input/output port 3.1, can be configured as AOPWM2 output
P3.2/NINT0	Input/output port 3.2, can be configured as INT0 input
P3.3/NINT1	Input/output port 3.3, can be configured as INT1 input
P3.5/T1	Input/output port 3.5, can be configured as Timer/Counter 1 input
P5.1/TSM	Input/output port 5.1, configured as JTAG port by default
P5.2/TDO	Input/output port 5.2, configured as JTAG port by default
P5.3/TDI	Input/output port 5.3, configured as JTAG port by default

### Analog Output Interface

P2.6/AOPWM0	Input/output, can be configured as 8-bit PWM output 0 with programmable carrier frequency
P2.7/AOPWM1	Input/output, can be configured as 8-bit PWM output 1 with programmable carrier frequency
P3.1/AOPWM2	Input/output, can be configured as 8-bit PWM output 2 with programmable carrier frequency

### Crystal Interface

XTAL0	Input, connected to crystal
XTAL1	Output, connected to crystal

### Reset Interface

RESET	Inout, system reset, needs to be pulled up to VDD1 but doesn't require external RC time constant
-------	--

### I<sup>2</sup>C Interface

SCL/SO-SI	Output, I <sup>2</sup> C clock output, or SPI data
SDA/CS0	Input/output, I <sup>2</sup> C Data line or SPI chip select 0

### I<sup>2</sup>C/SPI Interface

SCL/SO-SI	Output, I <sup>2</sup> C clock output, or SPI data
SDA/CS0	Input/output, I <sup>2</sup> C data line or SPI chip select 0

P1.3/SYNC/SCK	Input/output port 1.3, can be configured as SYNC output or SPI clock output, needs to be pulled up to VDD1 in order to boot from I <sup>2</sup> C EEPROM
P3.0/INT2/CS1	Input/output port 3.0, can be configured as INT2 input or SPI chip select 1

## 4.2 Motion Peripheral Interface Group

### PWM

PWMUH	Output, PWM phase U high side gate signal
PWMUL	Output, PWM phase U low side gate signal
PWMVH	Output, PWM phase V high side gate signal
PWMVL	Output, PWM phase V low side gate signal
PWMWH	Output, PWM phase W high side gate signal
PWMWL	Output, PWM phase W low side gate signal

### Fault

GATEKILL	Input, upon assertion, this negates all six PWM signals, programmable logic sense
----------	---

## 4.3 Analog Interface Group

AVDD	Analog power (1.8V)
AVSS	Analog power return
AREF	0.6V buffered output
CMEXT	Unbuffered 0.6V, input to the AREF buffer, capacitor needs to be connected.
IFB+	Input, Operational amplifier positive input for shunt resistor current sensing
IFB-	Input, Operational amplifier negative input for shunt resistor current sensing
IFBO	Output, Operational amplifier output for shunt resistor current sensing
AIN0	Input, Analog input channel 0 (0 – 1.2V), typically configured for DC bus voltage input
AIN1	Input, Analog input channel 1 (0 – 1.2V), needs to be pulled down to AVSS if unused
AIN2	Input, Analog input channel 2 (0 – 1.2V), needs to be pulled down to AVSS if unused
AIN3	Input, Analog input channel 3 (0 – 1.2V), needs to be pulled down to AVSS if unused
AIN4	Input, Analog input channel 4 (0 – 1.2V), needs to be pulled down to AVSS if unused
AIN5	Input, Analog input channel 5 (0 – 1.2V), needs to be pulled down to AVSS if unused
AIN6	Input, Analog input channel 6 (0 – 1.2V), needs to be pulled down to AVSS if unused

#### 4.4 Power Interface Group

VDD1	Digital power for I/O (3.3V)
VDD2	Digital power for core logic (1.8V)
VSS	Digital common
PLLVD	PLL power (1.8V)
PLLVSS	PLL ground return

#### 4.5 Test Interface Group

TSTMOD	Must be tied to VSS, used only for factory testing.
P5.1/TSM	Input/output port 5.1, configured as JTAG port by default
P5.2/TDO	Input/output port 5.2, configured as JTAG port by default
P5.3/TDI	Input/output port 5.3, configured as JTAG port by default
TCK	Input, JTAG test clock

## 5 Application Connections

Typical application connection is shown in Figure 5. All components necessary to implement a complete sensorless drive control algorithm are shown connected to IRMCF341.

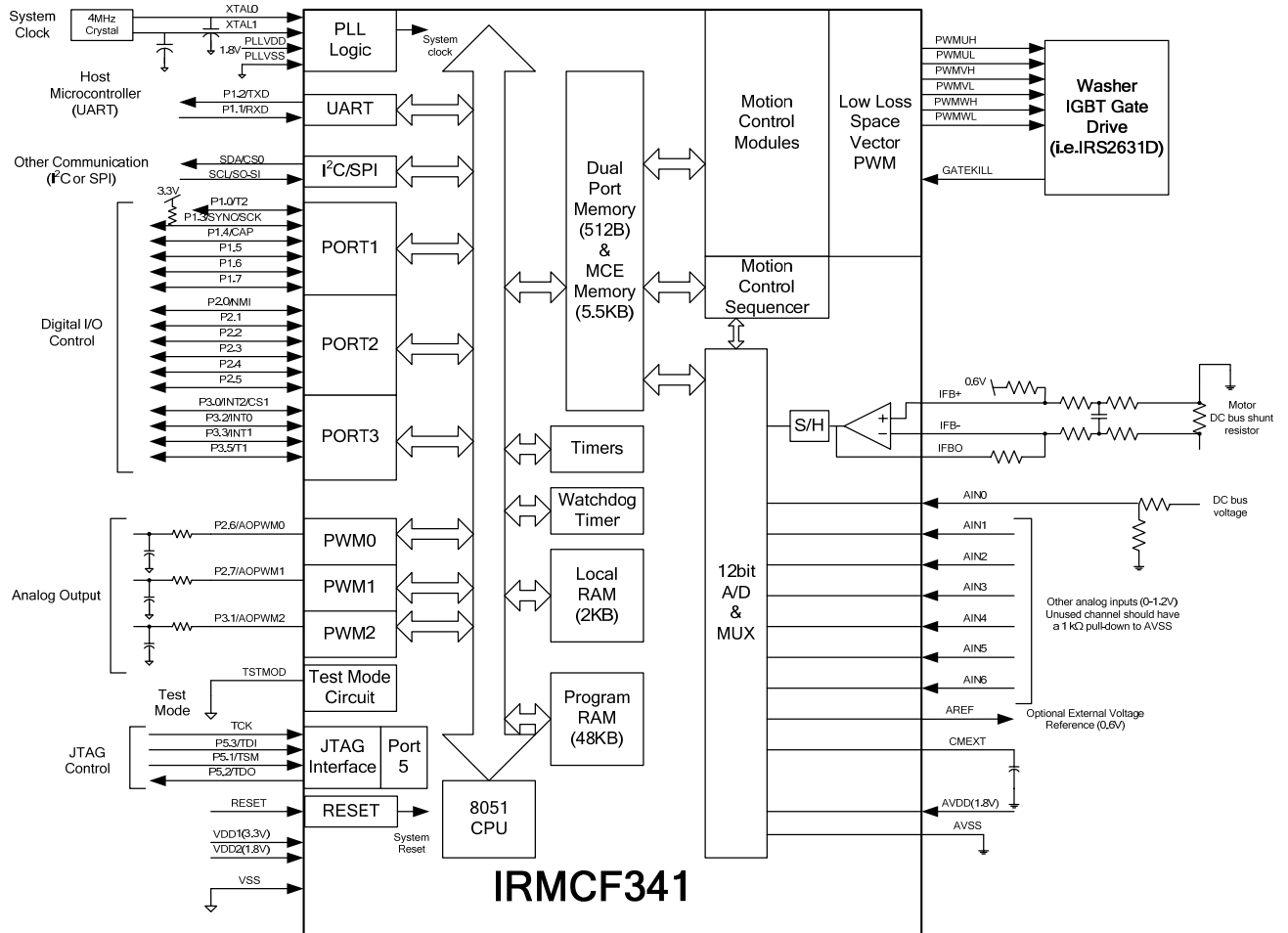

Figure 5. Application Connection of IRMCF341

## 6 DC Characteristics

### 6.1 Absolute Maximum Ratings

Symbol	Parameter	Min	Typ	Max	Condition
V <sub>DD1</sub>	Supply Voltage	-0.3 V	-	3.6 V	Respect to VSS
V <sub>DD2</sub>	Supply Voltage	-0.3 V	-	1.98 V	Respect to VSS
V <sub>IA</sub>	Analog Input Voltage	-0.3 V	-	1.98 V	Respect to AVSS
V <sub>ID</sub>	Digital Input Voltage	-0.3 V	-	3.65 V	Respect to VSS
T <sub>A</sub>	Ambient Temperature	-40 °C	-	85 °C	
T <sub>S</sub>	Storage Temperature	-65 °C	-	150 °C	

**Table 1. Absolute Maximum Ratings**

**Caution:** Stresses beyond those listed in “Absolute Maximum Ratings” may cause permanent damage to the device. These are stress ratings only and function of the device at these or any other conditions beyond those indicated in the operational sections of the specifications are not implied.

### 6.2 System Clock Frequency and Power Consumption

Symbol	Parameter	Min	Typ	Max	Unit
SYSCLOCK	System Clock	32	-	128	MHz

**Table 2. System Clock Frequency**

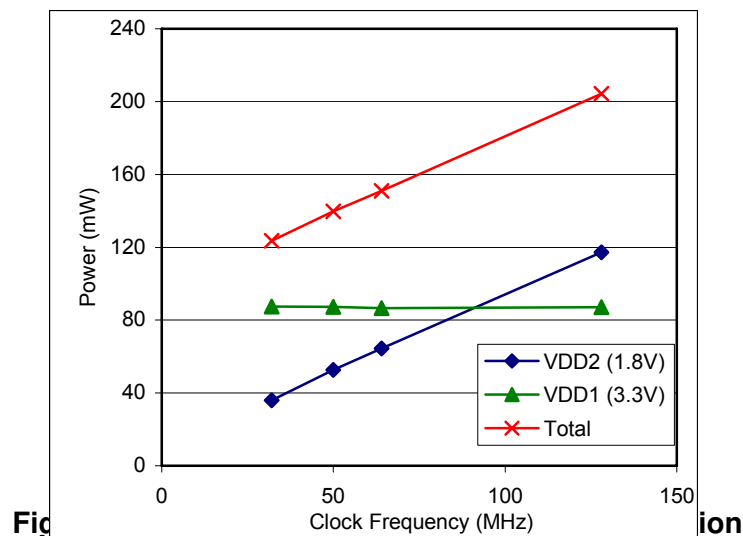

### 6.3 Digital I/O DC Characteristics

Symbol	Parameter	Min	Typ	Max	Condition
V <sub>DD1</sub>	Supply Voltage	3.0 V	3.3 V	3.6 V	Recommended
V <sub>DD2</sub>	Supply Voltage	1.62 V	1.8 V	1.98 V	Recommended
V <sub>IL</sub>	Input Low Voltage	-0.3 V	-	0.8 V	Recommended
V <sub>IH</sub>	Input High Voltage	2.0 V		3.6 V	Recommended
C <sub>IN</sub>	Input capacitance	-	3.6 pF	-	(1)
I <sub>L</sub>	Input leakage current		±10 nA	±1 µA	V <sub>O</sub> = 3.3 V or 0 V
I <sub>OL1</sub> <sup>(2)</sup>	Low level output current	8.9 mA	13.2 mA	15.2 mA	V <sub>OL</sub> = 0.4 V (1)
I <sub>OH1</sub> <sup>(2)</sup>	High level output current	12.4 mA	24.8 mA	38 mA	V <sub>OH</sub> = 2.4 V (1)
I <sub>OL2</sub> <sup>(3)</sup>	Low level output current	17.9 mA	26.3 mA	33.4 mA	V <sub>OL</sub> = 0.4 V (1)
I <sub>OH2</sub> <sup>(3)</sup>	High level output current	24.6 mA	49.5 mA	81 mA	V <sub>OH</sub> = 2.4 V (1)

**Table 3. Digital I/O DC Characteristics**

**Note:**

- (1) Data guaranteed by design.
- (2) Applied to SCL/SO-SI, SDA/CS0 pins.
- (3) Applied to P1.0/T2, P1.1/RXD, P1.2/TXD, P1.3/SYNC/SCK, P1.4/CAP, P1.5, P1.6, P1.7, P2.0/NMI, P2.1, P2.2, P2.3, P2.4, P2.5, P2.6/AOPWM0, P2.7/AOPWM1, P3.0/INT2/CS1, P3.1/AOPWM2, P3.2/INT0, P3.3/INT1, P3.5/T1, P3.6/RXD1, P3.7/TXD1, P5.1/TMS, P5.2/TDO, P5.3/TDI, GATEKILL, PWMUL, PWMUH, PWMVL, PWMVH, PWMWL, and PWMWH pins.

## 6.4 PLL and Oscillator DC characteristics

Symbol	Parameter	Min	Typ	Max	Condition
V <sub>PLLVD</sub>	Supply Voltage	1.62 V	1.8 V	1.92 V	Recommended
V <sub>IL OSC</sub>	Oscillator Input Low Voltage	V <sub>PLLSS</sub>	-	0.2* V <sub>PLLVD</sub>	V <sub>PLLVD</sub> = 1.8 V (1)
V <sub>IH OSC</sub>	Oscillator Input High Voltage	0.8* V <sub>PLLVD</sub>		V <sub>PLLVD</sub>	V <sub>PLLVD</sub> = 1.8 V (1)

**Table 4. PLL DC Characteristics**

Note:

(1) Data guaranteed by design.

## 6.5 Analog I/O DC Characteristics

- OP amp for current sensing (IFB+, IFB-, IFBO)

C<sub>AREF</sub> = 1nF, C<sub>MEXT</sub> = 100nF. Unless specified, Ta = 25°C.

Symbol	Parameter	Min	Typ	Max	Condition
V <sub>AVDD</sub>	Supply Voltage	1.71 V	1.8 V	1.89 V	Recommended
V <sub>OFFSET</sub>	Input Offset Voltage	-	-	26 mV	V <sub>AVDD</sub> = 1.8 V
V <sub>I</sub>	Input Voltage Range	0 V		1.2 V	Recommended
V <sub>OUTSW</sub>	OP amp output operating range	50 mV (1)	-	1.2 V	V <sub>AVDD</sub> = 1.8 V
C <sub>IN</sub>	Input capacitance	-	3.6 pF	-	(1)
R <sub>FDBK</sub>	OP amp feedback resistor	5 kΩ	-	20 kΩ	Requested between IFBO and IFB-
OP <sub>GAINCL</sub>	Operating Close loop Gain	80 db	-	-	(1)
CMRR	Common Mode Rejection Ratio	-	80 db	-	(1)
I <sub>SRC</sub>	Op amp output source current	-	1 mA	-	V <sub>OUT</sub> = 0.6 V (1)
I <sub>SNK</sub>	Op amp output sink current	-	100 μA	-	V <sub>OUT</sub> = 0.6 V (1)

**Table 5. Analog I/O DC Characteristics**

Note:

(1) Data guaranteed by design.



## 6.6 Under Voltage Lockout DC characteristics

- Based on AVDD (1.8V)

Unless specified,  $T_a = 25^\circ\text{C}$ .

Symbol	Parameter	Min	Typ	Max	Condition
$UV_{CC+}$	UVcc positive going Threshold	1.53 V	1.66 V	1.71 V	$V_{DD1} = 3.3\text{ V}$
$UV_{CC-}$	UVcc negative going Threshold	1.52 V	1.62 V	1.71 V	$V_{DD1} = 3.3\text{ V}$
$UV_{CCH}$	UVcc Hysteresys	-	40 mV	-	

**Table 6. UVcc DC Characteristics**

## 6.7 CMEXT and AREF Characteristics

$C_{AREF} = 1\text{nF}$ ,  $C_{MEXT} = 100\text{nF}$ . Unless specified,  $T_a = 25^\circ\text{C}$ .

Symbol	Parameter	Min	Typ	Max	Condition
$V_{CM}$	CMEXT voltage	495 mV	600 mV	700 mV	$V_{AVDD} = 1.8\text{ V}$
$V_{AREF}$	Buffer Output Voltage	495 mV	600 mV	700 mV	$V_{AVDD} = 1.8\text{ V}$
$\Delta V_o$	Load regulation ( $V_{DC}-0.6$ )	-	1 mV	-	(1)
PSRR	Power Supply Rejection Ratio	-	75 db	-	(1)

**Table 7. CMEXT and AREF DC Characteristics**

## 7 AC Characteristics

### 7.1 PLL AC Characteristics

Symbol	Parameter	Min	Typ	Max	Condition
$F_{CLKIN}$	Crystal input frequency	3.2 MHz	4 MHz	60 MHz	<sup>(1)</sup> (see figure below)
$F_{PLL}$	Internal clock frequency	32 MHz	50 MHz	128 MHz	<sup>(1)</sup>
$F_{LWPW}$	Sleep mode output frequency	$F_{CLKIN} \div 256$	-	-	<sup>(1)</sup>
$J_S$	Short time jitter	-	200 psec	-	<sup>(1)</sup>
D	Duty cycle	-	50 %	-	<sup>(1)</sup>
$T_{LOCK}$	PLL lock time	-	-	500 $\mu$ sec	<sup>(1)</sup>

**Table 8. PLL AC Characteristics**

Note:

(1) Data guaranteed by design.

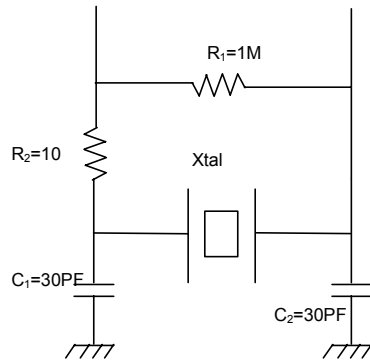

## 7.2 Analog to Digital Converter AC Characteristics

Unless specified,  $T_a = 25^\circ\text{C}$ .

Symbol	Parameter	Min	Typ	Max	Condition
$T_{\text{CONV}}$	Conversion time	-	-	2.05 $\mu\text{sec}$	<sup>(1)</sup>
$T_{\text{HOLD}}$	Sample/Hold maximum hold time	-	-	10 $\mu\text{sec}$	Voltage droop $\leq$ 15 LSB (see figure below)

**Table 9. A/D Converter AC Characteristics**

Note:

(1) Data guaranteed by design.

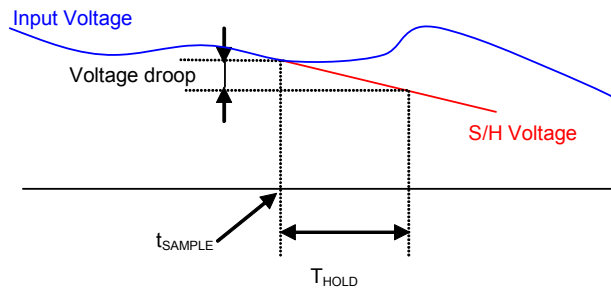

### 7.3 Op amp AC Characteristics

- OP amp for current sensing (IFB+, IFB-, IFBO)

Unless specified, Ta = 25°C.

Symbol	Parameter	Min	Typ	Max	Condition
OP <sub>SR</sub>	OP amp slew rate	-	10 V/μsec	-	V <sub>AVDD</sub> = 1.8 V, CL = 33 pF <sup>(1)</sup>
OP <sub>IMP</sub>	OP input impedance	-	10 <sup>8</sup> Ω	-	<sup>(1)</sup>
T <sub>SET</sub>	Settling time	-	400 ns	-	V <sub>AVDD</sub> = 1.8 V, CL = 33 pF <sup>(1)</sup>

**Table 10. Current Sensing OP Amp AC Characteristics**

Note:

(1) Data guaranteed by design.

## 7.4 SYNC to SVPWM and A/D Conversion AC Timing

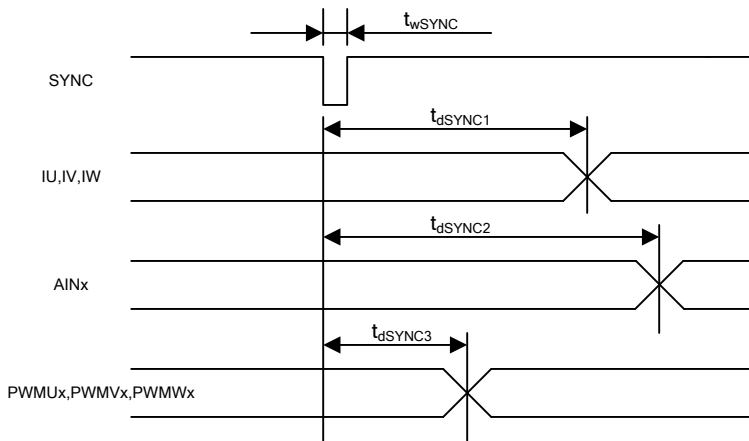

Unless specified,  $T_a = 25^\circ\text{C}$ .

Symbol	Parameter	Min	Typ	Max	Unit
$t_{wSYNC}$	SYNC pulse width	-	32	-	SYSClk
$t_{dSYNC1}$	SYNC to current feedback conversion time	-	-	100	SYSClk
$t_{dSYNC2}$	SYNC to AIN0-6 analog input conversion time	-	-	200	SYSClk <sup>(1)</sup>
$t_{dSYNC3}$	SYNC to PWM output delay time	-	-	2	SYSClk

**Table 11. SYNC AC Characteristics**

Note:

(1) AIN1 through AIN6 channels are converted once every 6 SYNC events

### 7.5 GATEKILL to SVPWM AC Timing

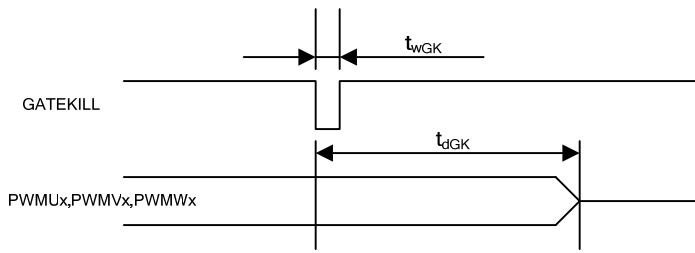

Unless specified, Ta = 25°C.

Symbol	Parameter	Min	Typ	Max	Unit
$t_{wGK}$	GATEKILL pulse width	32	-	-	SYSClk
$t_{dGK}$	GATEKILL to PWM output delay	-	-	100	SYSClk

**Table 12. GATEKILL to SVPWM AC Timing**

### 7.6 Interrupt AC Timing

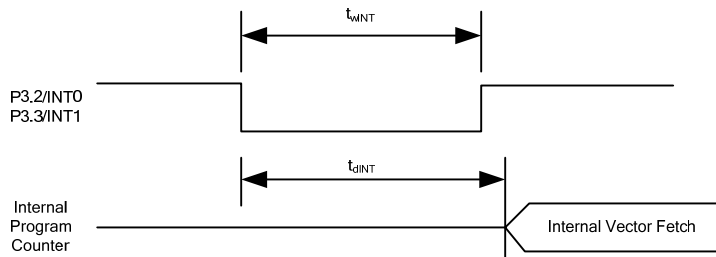

Unless specified, Ta = 25°C.

Symbol	Parameter	Min	Typ	Max	Unit
$t_{wINT}$	INT0, INT1 Interrupt Assertion Time	4	-	-	SYSClk
$t_{dINT}$	INT0, INT1 latency	-	-	4	SYSClk

**Table 13. Interrupt AC Timing**

## 7.7 I<sup>2</sup>C AC Timing

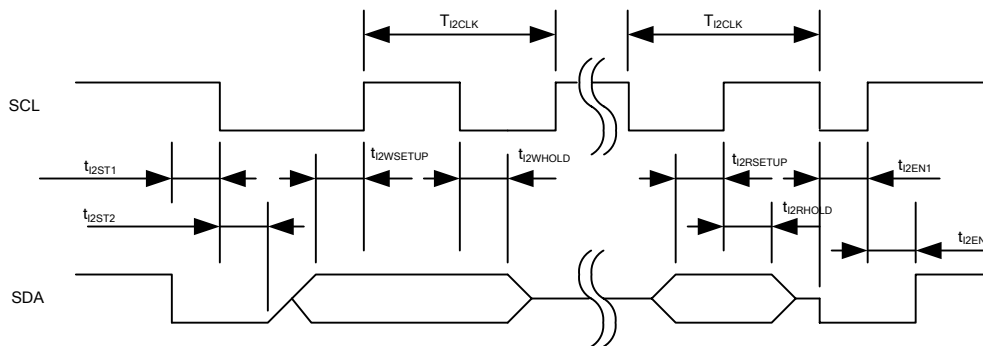

Unless specified,  $T_a = 25^\circ\text{C}$ .

Symbol	Parameter	Min	Typ	Max	Unit
$T_{I2CLK}$	I <sup>2</sup> C clock period	10	-	8192	SYCLK
$t_{I2ST1}$	I <sup>2</sup> C SDA start time	0.25	-	-	$T_{I2CLK}$
$t_{I2ST2}$	I <sup>2</sup> C SCL start time	0.25	-	-	$T_{I2CLK}$
$t_{I2WSETUP}$	I <sup>2</sup> C write setup time	0.25	-	-	$T_{I2CLK}$
$t_{I2WHOLD}$	I <sup>2</sup> C write hold time	0.25	-	-	$T_{I2CLK}$
$t_{I2RSETUP}$	I <sup>2</sup> C read setup time	I <sup>2</sup> C filter time <sup>(1)</sup>	-	-	SYCLK
$t_{I2RHOLD}$	I <sup>2</sup> C read hold time	1	-	-	SYCLK

Table 14. I<sup>2</sup>C AC Timing

Note:

- (1) I<sup>2</sup>C read setup time is determined by the programmable filter time applied to I<sup>2</sup>C communication.

## 7.8 SPI AC Timing

### 7.8.1 SPI Write AC timing

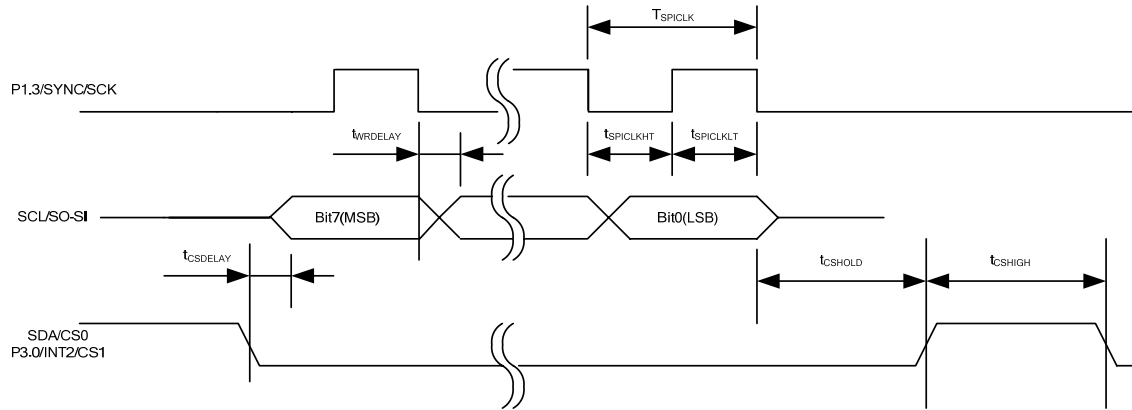

Unless specified,  $T_a = 25^\circ\text{C}$ .

Symbol	Parameter	Min	Typ	Max	Unit
$T_{\text{SPICLK}}$	SPI clock period	4	-	-	SYSCLK
$t_{\text{SPICLKHT}}$	SPI clock high time	-	1/2	-	$T_{\text{SPICLK}}$
$t_{\text{SPICLKLT}}$	SPI clock low time	-	1/2	-	$T_{\text{SPICLK}}$
$t_{\text{CSDELAY}}$	CS to data delay time	-	-	10	nsec
$t_{\text{WRDELAY}}$	CLK falling edge to data delay time	-	-	10	nsec
$t_{\text{CSHIGH}}$	CS high time between two consecutive byte transfer	1	-	-	$T_{\text{SPICLK}}$
$t_{\text{CSHOLD}}$	CS hold time	-	1	-	$T_{\text{SPICLK}}$

Table 15. SPI Write AC Timing



### 7.8.2 SPI Read AC Timing

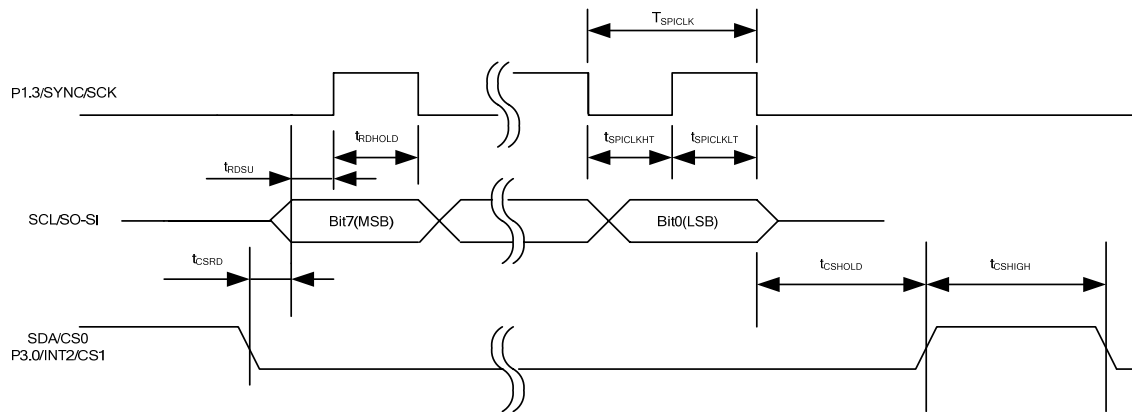

Unless specified,  $T_a = 25^\circ\text{C}$ .

Symbol	Parameter	Min	Typ	Max	Unit
$T_{\text{SPICLK}}$	SPI clock period	4	-	-	SYSCCLK
$t_{\text{SPICLKHT}}$	SPI clock high time	-	1/2	-	$T_{\text{SPICLK}}$
$t_{\text{SPICLKLT}}$	SPI clock low time	-	1/2	-	$T_{\text{SPICLK}}$
$t_{\text{CSRd}}$	CS to data delay time	-	-	10	nsec
$t_{\text{RDSU}}$	SPI read data setup time	10	-	-	nsec
$t_{\text{RDHOLD}}$	SPI read data hold time	10	-	-	nsec
$t_{\text{CSHIGH}}$	CS high time between two consecutive byte transfer	1	-	-	$T_{\text{SPICLK}}$
$t_{\text{CSHOLD}}$	CS hold time	-	1	-	$T_{\text{SPICLK}}$

Table 16. SPI Read AC Timing

## 7.9 UART AC Timing

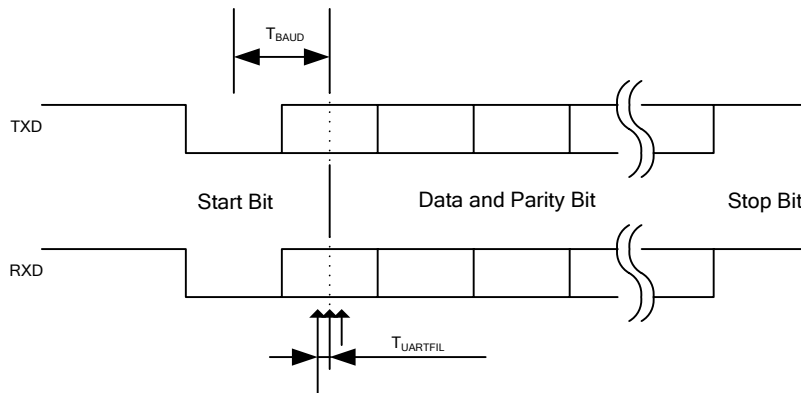

Unless specified,  $T_a = 25^\circ\text{C}$ .

Symbol	Parameter	Min	Typ	Max	Unit
$T_{BAUD}$	Baud Rate Period	-	57600	-	bit/sec
$T_{UARTFIL}$	UART sampling filter period <sup>(1)</sup>	-	1/16	-	$T_{BAUD}$

**Table 17. UART AC Timing**

Note:

- (1) Each bit including start and stop bit is sampled three times at center of a bit at an interval of  $1/16 T_{BAUD}$ . If three sampled values do not agree, then UART noise error is generated.