



Chipsmall Limited consists of a professional team with an average of over 10 year of expertise in the distribution of electronic components. Based in Hongkong, we have already established firm and mutual-benefit business relationships with customers from,Europe,America and south Asia,supplying obsolete and hard-to-find components to meet their specific needs.

With the principle of “Quality Parts,Customers Priority,Honest Operation,and Considerate Service”,our business mainly focus on the distribution of electronic components. Line cards we deal with include Microchip,ALPS,ROHM,Xilinx,Pulse,ON,Everlight and Freescale. Main products comprise IC,Modules,Potentiometer,IC Socket,Relay,Connector.Our parts cover such applications as commercial,industrial, and automotives areas.

We are looking forward to setting up business relationship with you and hope to provide you with the best service and solution. Let us make a better world for our industry!



Contact us

Tel: +86-755-8981 8866 Fax: +86-755-8427 6832

Email & Skype: info@chipsmall.com Web: www.chipsmall.com

Address: A1208, Overseas Decoration Building, #122 Zhenhua RD., Futian, Shenzhen, China



IR2233 Reference Design Kit: 3-Phase 460VAC 3HP Motor Drive

Product Description

The IRMDAC3 Reference Design is a kit of parts that work together as an evaluation platform for IR2233 three phase motor control IC and IRPT2062A power module. User connects three phase AC, drive signals, motor and hall sensors to complete the system. Power hook-up is via terminal blocks and control signals are made using a single in line header.

How the IR2233 Control IC Adds Value

- Monolithic HVIC Integrates Control and Drive Yields Compact, Robust, Economical Designs
- Allows Elegant, Convenient System Partition
- Compatible with Short Circuit, Ground Fault and Over-Temperature Protection Schemes

How the Power Module Adds Value

- Integration of All Inverter Power Components;
- Low Parasitic Coupling = High Performance
- Current Sensing Shunts in DC Feed and Return
- Onboard Temperature Sensor
- Easily Mounted Package
- Short Circuit Rated, Ultrafast IGBT Gen #4
- Wide Operating Temperature Range
- Metal Base gives Excellent Thermal Transfer and Isolation to 2500V RMS

System Block Diagram *Fig 2*

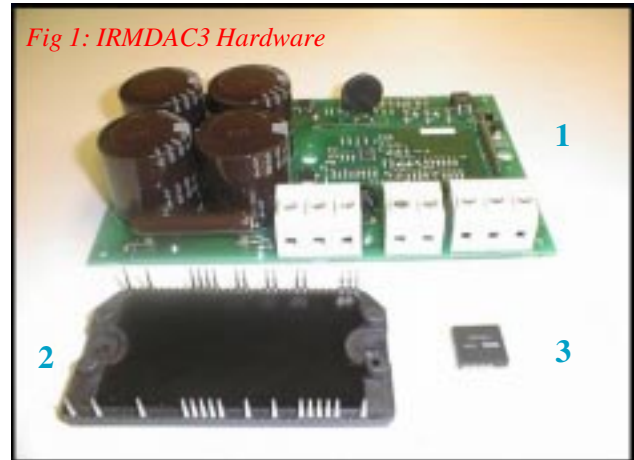
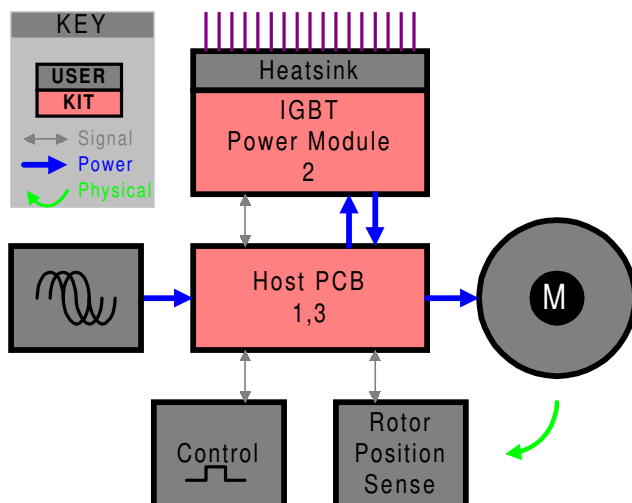

Kit Content

- 1 Host PCB for Input Processing and Control
- 2 IRPT2062A Integrated Power Module
- 3 IR2233 Three Phase Motor Control IC
- Technical Contact and License Detail
- Schematic and PCB Layout Data
- Bill of Materials and Supplier Information

System Features

- 460V Three Phase AC Inlet, 50/60Hz
- Convenient Signal and Power Terminations
- Inrush Current Limit and Surge Suppression
- Integral +15V and +5V Bias Supplies
- DC Bus Voltage and Current Feedback
- 150% Overload Capability (1 Minute)
- Optimized Drive for Power Module
- Includes **Brake Switch** and Drive

Fig 3

IRMDAC3
 Host PCB
 Bottom Layer



IRMDAC3 Kit Overview and System Benefits

- When furnished with user-provided logic level control signals, the IRMDAC3 forms a complete reference design for a 3HP AC motor. Unlike outdated circuits based upon transformer drive or opto-couplers, the system uses International Rectifier proprietary level-shifting gate drive circuits integrated within the IR2233J Control IC. Separation of gate drive / control and low-voltage circuits from the power module included in the kit results in a compact, efficient system. The user benefits from immediate hands-on experience and may customize at will using schematics and circuit ideas as the basis for production designs.
- Gate drive, control and protection circuits are designed to closely match the operating characteristics of the power semiconductors. This allows power losses to be minimized and power rating to be enhanced to a greater extent than is possible by designing with individual components.

1. Host PCB Description

The host PCB receives power input from a 3-phase line and control signals provided by the user. In conjunction with the power module the result is a flexible power conversion system, primarily designed for interface with a 3HP Motor, however other 3-phase loads may also be applied. The host PCB supports soft-start function which reduces inrush current by using an NTC thermistor. Surge suppression is implemented using MOV's as a further degree of protection. Also on-board is a regulated low voltage power supply to provide bias for the IR2233J and other low voltage components. When connected to the power module, the unit is fully protected against overcurrent and ground faults through DC bus voltage and current feedback. Over-temperature is guarded against through feedback from a thermistor embedded within the power module. A 16-pin single in line header connector is provided to interface control signals and two terminal blocks connect 3-phase AC inlet and output to the load. The user provides 5V CMOS / TTL level signals which are then processed by the IR2233J Control IC and delivered to the power module.

Signals Available to User

In addition to availability of bias supplies derived for the host PCB, signals from the power module circuits and those derived and processed on the host PCB such as fault status are available to the user. Current feedback signal from the low side shunt is available on the IFB pin at 0.025V/A. If filtering of this signal is required to remove noise, a high impedance buffer stage should be inserted between signal and filter. DC bus voltage feedback is provided on the VFB pin. This reference is been scaled down by a factor of 100 and should be protected with a high impedance buffer stage.

Fault Behavior.

The system is designed to tolerate overload conditions for one minute. The user should prevent such conditions persisting beyond this period. In the event of shutdown initiated by ground-fault, overcurrent or over-temperature, the inverter outputs are terminated and an LED will light to signal this condition. For more information on fault response for IR2233J, please consult the data sheet.

Brake Function

In order to use the integrated brake switch, an external power resistor should be connected between pins BR and P of terminal block J5. This resistor should be dimensioned for desired braking performance. Carefully choose the value of this component to ensure the brake IGBT integrated within the power module remains below its maximum current capability.

2. Power Module Description

The power module integrates all rectifiers, ultra-fast short circuit rated IGBTs, fast recovery commutation diodes, brake IGBT and other processing components needed for a 3HP Motor Drive or other loads requiring a 3-phase variable frequency and/or PWM drive. Semiconductor dice are mounted on a thermally efficient substrate and housed within a convenient, potted module. When connected to the host PCB, the power components become configured as a 3-phase input bridge rectifier, and IGBT inverter with current sensing shunt resistors. An NTC thermistor is bonded to the substrate to furnish the host PCB with accurate temperature reading. A galvanically isolated metal backplate provides excellent thermal coupling to an external heatsink, which is necessary for full-load operation.

Circuit Layout within the module is carefully designed to minimize inductance in the power path, reduce noise during inverter operation and to improve inverter efficiency. The IR2233 host board should be soldered to the power module pins to complete the assembly. For detailed electrical specifications, please refer to the power module datasheet.

Power Module Mounting and Hook-up Instructions

1. Remove all particles and grit from the heatsink and power substrate
2. Spread a thin layer of silicone grease on the heatsink, covering the entire area that the power substrate will occupy
3. Place the power substrate onto the heatsink with the mounting holes aligned and press firmly into the grease
4. Place the 2XM4 mounting screws and tighten to 1NM torque

External Connections

All input and output control connections are made via a 16-terminal single in line connector J6. Three phase input connections are made to terminals R,S and T of J1. Inverter output terminal connections are made to terminals U,V and W of J7. Positive DC Bus and brake IGBT collector connections are available on terminals P and BR respectively of J5. An external power resistor may be connected between P and BR to dissipate braking energy.

Power-Up Procedure

Upon application of 3-phase input power, PWM inputs must be held high until the protection latch circuitry is reset. To reset this latch before inverter start-up, RESET pin on J6 connector must be pulled down low for at least 2usec. This will set the Fault feedback signal on J6 high. PWM input signals may then be actively driven.

Figure 4 Signal Connector

Figure 5 Power Terminal Blocks

Figure 6 Power Module Mounting Screw Sequence

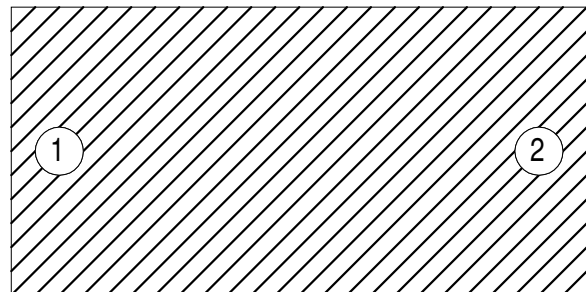
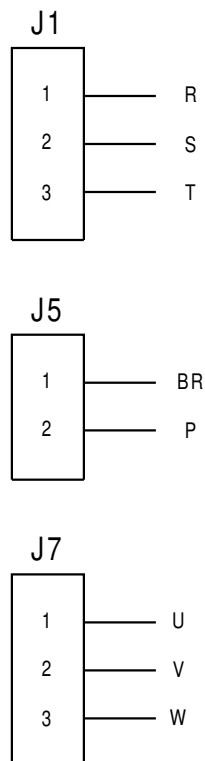
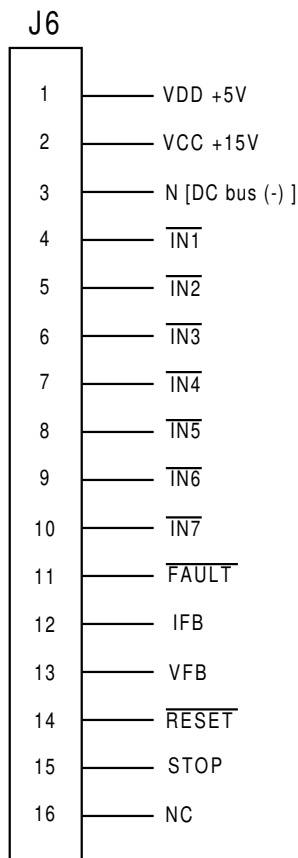

Mechanical Details

Figure 7

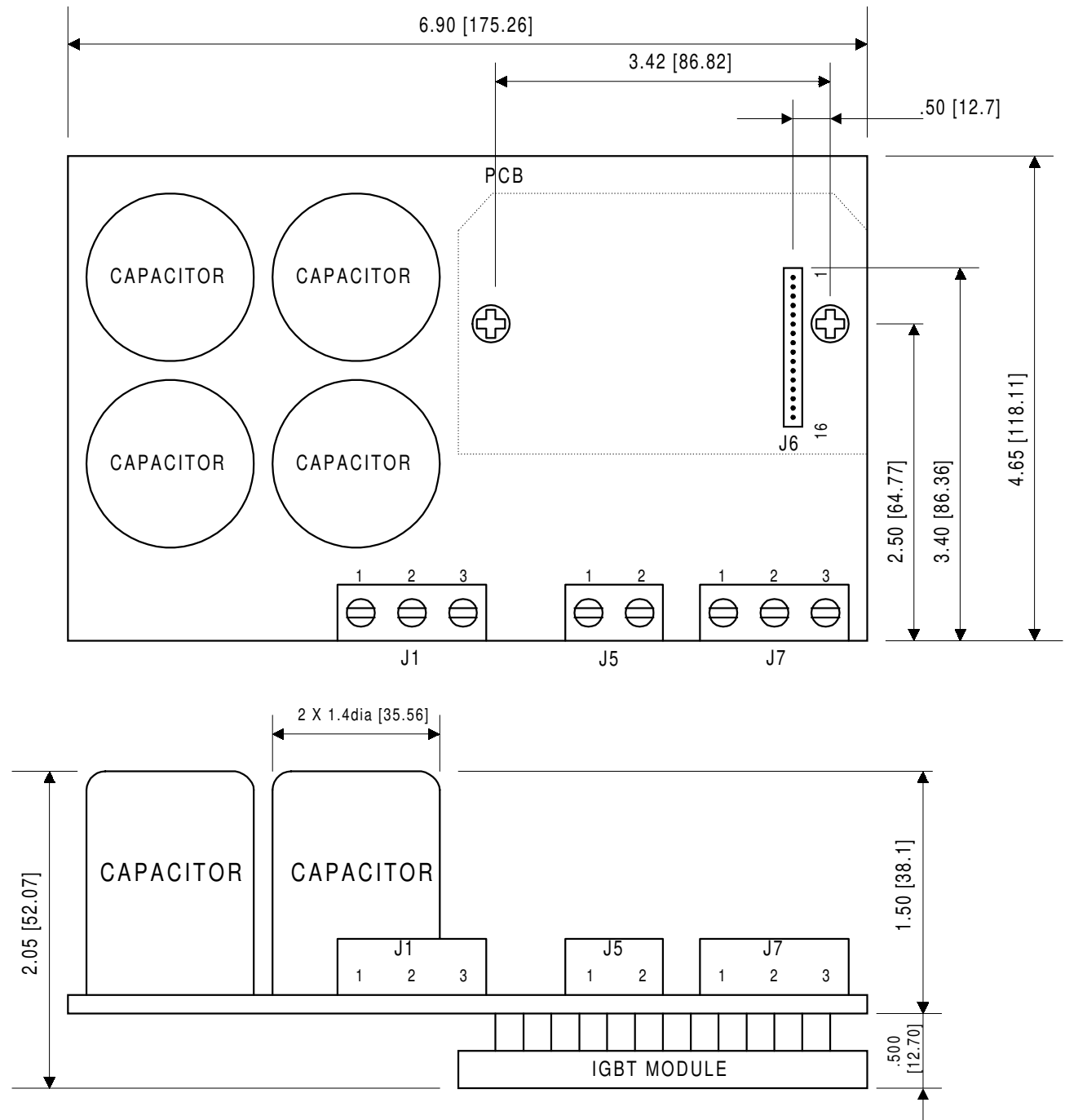

Figure 8: Efficiency Maximization Charts Extract From Module Data Sheet

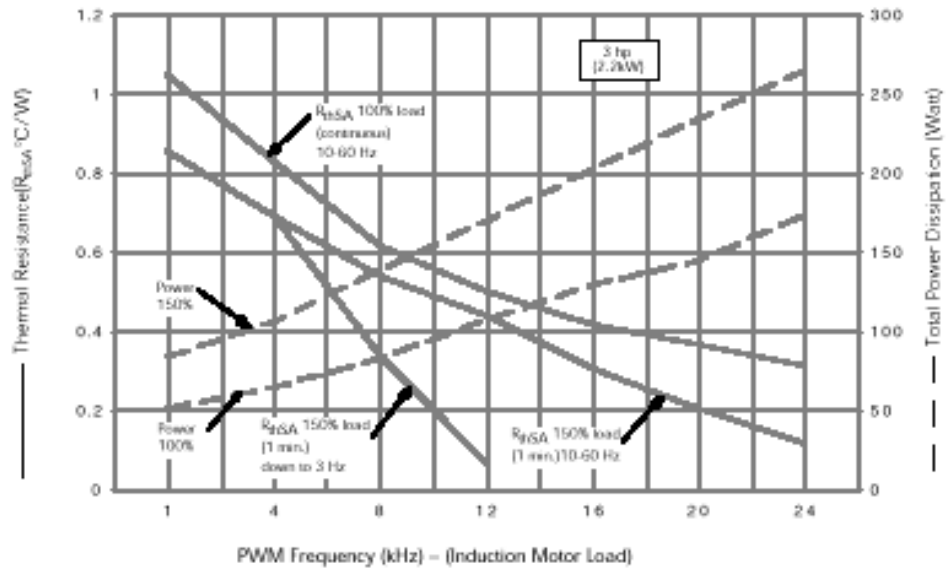

Figure 4a. 3 hp/5.9A Output Heat Sink Thermal Resistance and Power Dissipation vs. PWM Frequency

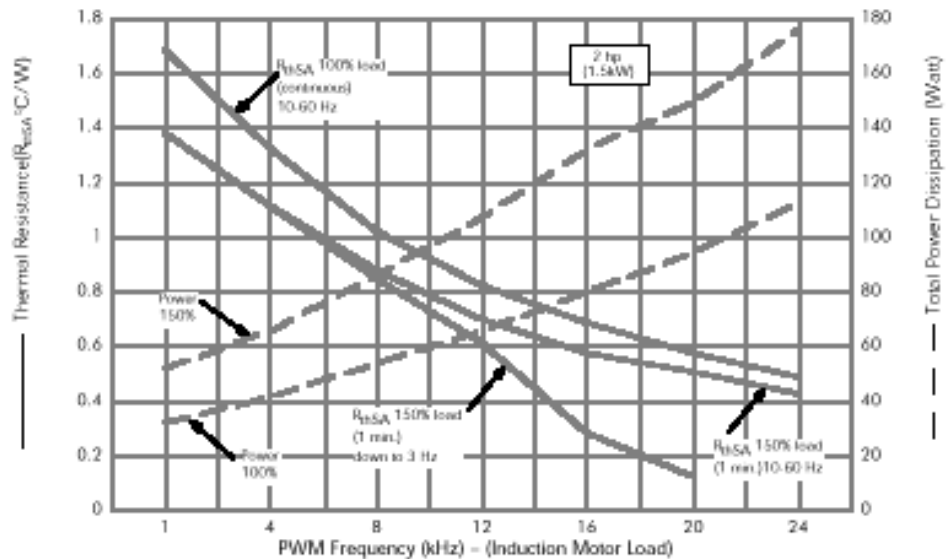

Figure 4b. 2 hp/4.2A Output Heat Sink Thermal Resistance and Power Dissipation vs. PWM Frequency

NOTE: For figures 4a and 4b: Operating Conditions: $V_{in} = 460V_{rms}$, $M = 1.15$, $PF = 0.8$, $T_A = 40^{\circ}\text{C}$, $T_c < 145^{\circ}\text{C}$, $T_s < 95^{\circ}\text{C}$, $Z_{\theta JA}$ limits ΔT_c during 1 minute overload to 10°C

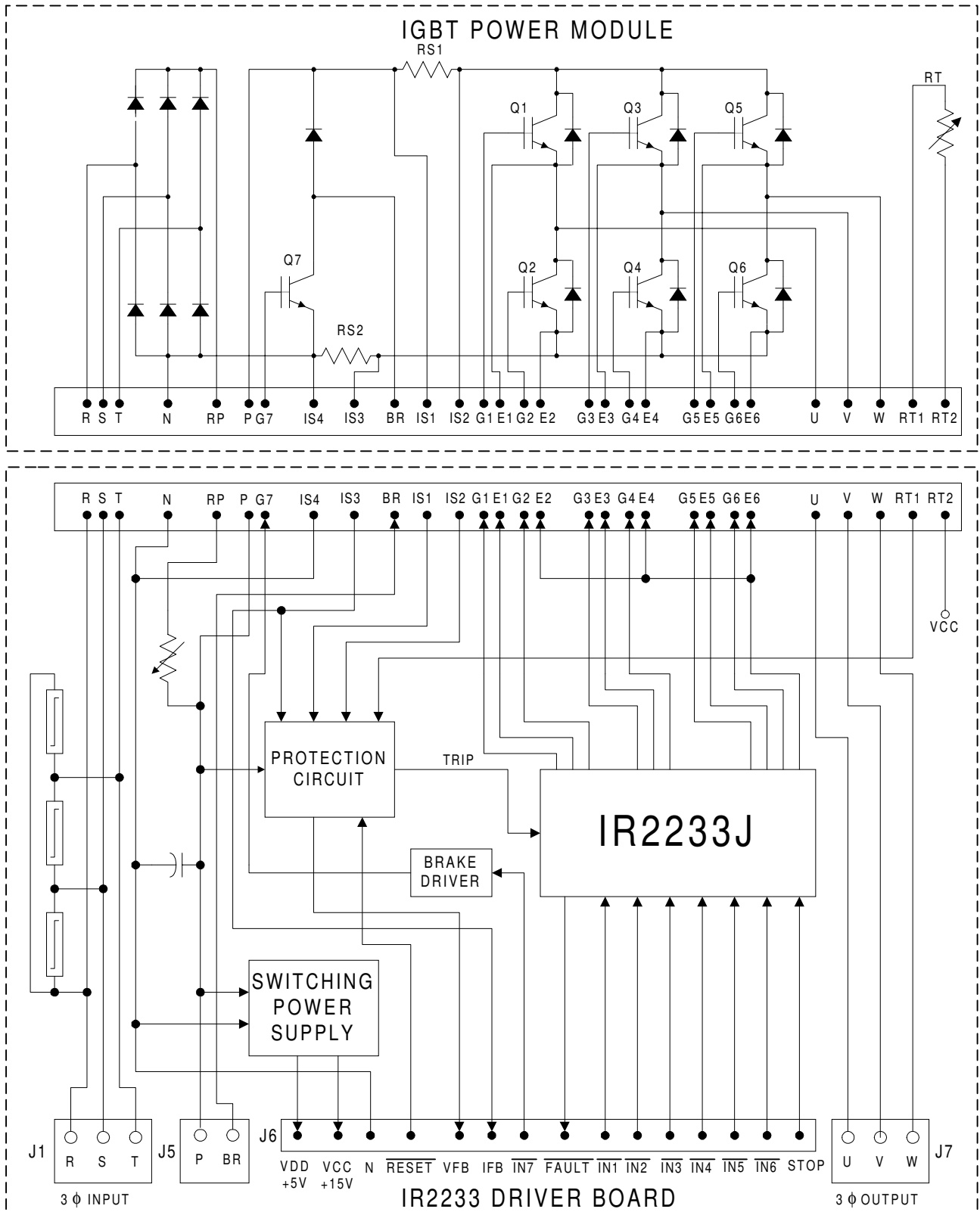

Figure 9: Technical Specifications @ Tc=25C Unless Stated Otherwise

Parameter	Value	Condition
POWER INPUTS		
Voltage	460Vrms- 20% + 10%	
Frequency	50 / 60 Hz	
Current	8.26A RMS @ Nominal Full Load Surge Max: 150A Peak	Ta=40C, RthSA= 0.42C / Watt
Line Impedance	4% to 8% Recommended	Line Reactor Required for Source Input Impedance <4%
POWER OUTPUTS		
Voltage	0-460Vrms	
Power	3HP (2.2KW) Nominal Power 150% Overload for 1 Minute	Vin=460VAC, Fpwm=4KHz, Fo=60Hz, Ta=40C, RthSA=0.42C / Watt ZthSA Limits Temp Rise During Overload
Current	5.9Arms Nominal, 8.85Arms Overload	
Brake	10.5A	Maximum Current
CONTROL INPUTS		
/In1.../In7,/Reset	5V Maximum (Active Low)	CMOS, LSTTL or Open Collector Compatible
Stop	5V Maximum (Active High)	CMOS, LSTTL
Deadtime	0.2uSec Minimum	See IR2233 Data
Minimum Input Pulse Width	1.0 uSec	Limited only by Bootstrap Capacitor. See Design Tip 98-2
PROTECTION		
Output Current Trip Level	28A Peak +/- 10%	
Ground Fault Trip Level	50A Peak +/- 10%	
Over-Temperature Trip	100C +/- 5%	Case Temperature
Over-Voltage Trip Level	850V +/- 10%	Maximum Persistence 30Sec
Maximum DC Link Voltage	800V	Maximum Persistence 30Sec
Minimum DC Link Voltage	150V	To Maintain Auxilliary Supply
Short Circuit Response Time	2.5Usec	Line to Line or Line to Bus
FEEDBACK		
Current (Ifb)	0.025V/Abus Typical	
Bus Voltage (Vfb)	0.010V/Vbus Typical	
Fault Feedback (/Fault)	5V Maximum (Active Low)	CMOS or LSTTL Compatible
AUXILLIARY SUPPLY		
Vcc	15V +/- 10%	
Vdd	5V +/- 5%	
Icc+Idd	60mA	Available to User
POWER MODULE		
Isolation Voltage	2500VAC 60Hz for 1 Minute	Pin to Baseplate Isolation
Operating Case Temp	-20C to +95C	95% RH Max (Non Condensing)
Mounting Torque	1 Newton Metre	M4 Screw
SYSTEM ENVIRONMENT		
Ambient Operating Temp	0 to 40C Recommended With Heatsink	95% RH Max (Non Condensing)

International
IR Rectifier

WORLD HEADQUARTERS: 233 Kansas St., El Segundo, California USA 90245: Tel: (310) 322 3331

EUROPEAN HEADQUARTERS: Hurst Green, Oxted, Surrey RH8 9BB, United Kingdom: Tel: ++ 44 1883 732020

IR CANADA: 7321 Victoria Park Ave., Suite 201, Markham, Ontario L3R 2Z8: Tel: (905) 475 1897

IR GERMANY: Saalburgstrasse 157, 61350 Bad Homburg Tel: ++ 49 6172 96590

IIR ITALY: Via Liguria 49, 10071 Borgaro, Torino Tel: ++ 39 11 451 0111

IR FAR EAST: 171 (K&H Bldg.), 30-4 Nishi-ikebukuro 3-Chome, Toshima-ku, Tokyo, Japan Tel: 81 3 3983 0086

IR SOUTHEAST ASIA: 315 Outram Road, #10-02 Tan Boon Liat Building, Singapore 0316 Tel: 65 221 8371

Worldwide Web

<http://www.irf.com>

Sales Offices, Agents and Distributors in Major Cities Throughout the World.

Data and specifications subject to change without notice.