



Chipsmall Limited consists of a professional team with an average of over 10 year of expertise in the distribution of electronic components. Based in Hongkong, we have already established firm and mutual-benefit business relationships with customers from,Europe,America and south Asia,supplying obsolete and hard-to-find components to meet their specific needs.

With the principle of "Quality Parts,Customers Priority,Honest Operation,and Considerate Service",our business mainly focus on the distribution of electronic components. Line cards we deal with include Microchip,ALPS,ROHM,Xilinx,Pulse,ON,Everlight and Freescale. Main products comprise IC,Modules,Potentiometer,IC Socket,Relay,Connector.Our parts cover such applications as commercial,industrial, and automotives areas.

We are looking forward to setting up business relationship with you and hope to provide you with the best service and solution. Let us make a better world for our industry!



Contact us

Tel: +86-755-8981 8866 Fax: +86-755-8427 6832

Email & Skype: info@chipsmall.com Web: www.chipsmall.com

Address: A1208, Overseas Decoration Building, #122 Zhenhua RD., Futian, Shenzhen, China



IRS210614S
HIGH AND LOW SIDE DRIVER

IC Features

- Floating channel designed for bootstrap operation
- Fully operational to +600 V
- Tolerant to negative transient voltage, dV/dt immune
- Gate drive supply range from 10 V to 20 V
- Undervoltage lockout for both channels
- 3.3 V, 5 V, and 15 V input logic compatible
- Matched propagation delay for both channels
- Logic and power ground +/- 5 V offset
- Lower di/dt gate driver for better noise immunity
- Outputs in phase with inputs
- RoHS compliant

Product Summary

Topology	Half-Bridge
V _{OFFSET}	600 V
V _{OUT}	10 V-20 V
I _{O+} & I _{O-} (typical)	290 mA & 600 mA
T _{on} & t _{off} (typical)	165 ns & 165 ns

Package Types



Typical Connection Diagram

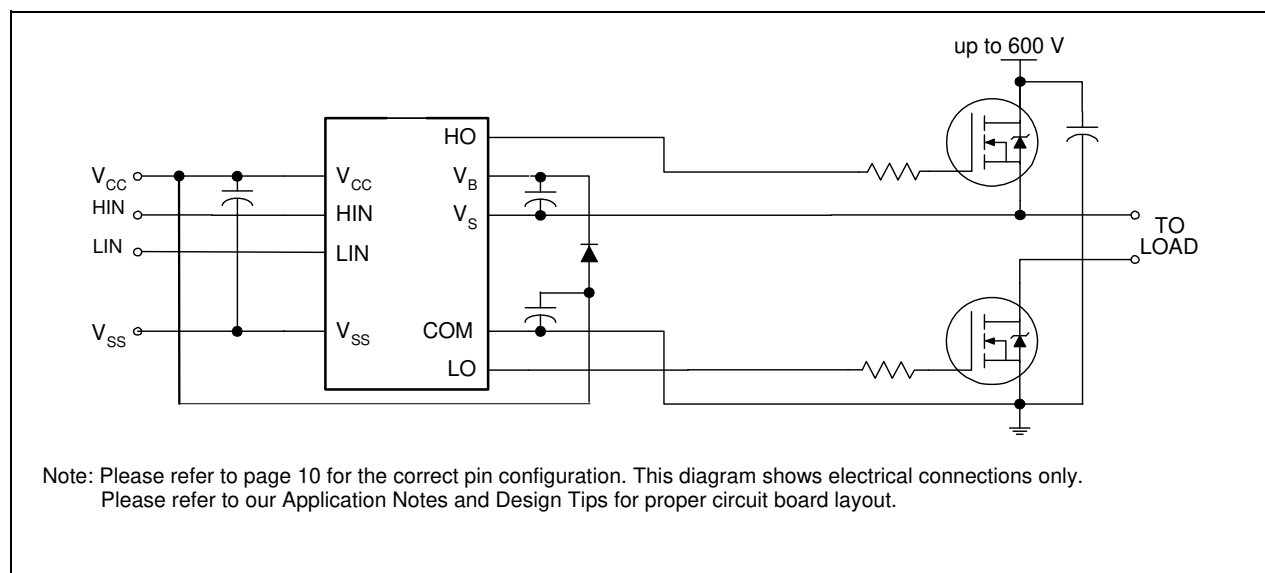

Table of Contents	Page
Description	3
Qualification Information	4
Absolute Maximum Ratings	5
Recommended Operating Conditions	6
Static Electrical Characteristics	7
Dynamic Electrical Characteristics	7
Functional Block Diagram	8
Input/Output Pin Equivalent Circuit Diagram	9
Lead Definitions	10
Lead Assignments	10
Waveform Definitions	11
Package Details	12
Tape and Reel Details	13
Part Marking Information	14
Ordering Information	15

Description

The IRS21064S is a high voltage, high speed power MOSFET and IGBT driver with independent high and low-side referenced output channels. Proprietary HVIC and latch immune CMOS technologies enable ruggedized monolithic construction. The logic input is compatible with standard CMOS or LSTTL output, down to 3.3 V logic. The output drivers feature a high pulse current buffer stage designed for minimum driver cross-conduction. The floating channel can be used to drive an N-channel power MOSFET or IGBT in the high side configuration which operates up to 600 V.

Qualification Information[†]

Qualification Level		Industrial ^{††}	
		Comments: This family of ICs has passed JEDEC's Industrial qualification. IR's Consumer qualification level is granted by extension of the higher Industrial level.	
Moisture Sensitivity Level		SOIC14N	MSL2 ^{†††} (per IPC/JEDEC J-STD-020)
ESD	Machine Model	Class B (per JEDEC standard EIA/JESD22-A115)	
	Human Body Model	Class 2 (per EIA/JEDEC standard JESD22-A114)	
IC Latch-Up Test		Class 1, Level A (per JESD78)	
RoHS Compliant		Yes	

† Qualification standards can be found at International Rectifier's web site <http://www.irf.com/>

†† Higher qualification ratings may be available should the user have such requirements. Please contact your International Rectifier sales representative for further information.

††† Higher MSL ratings may be available for the specific package types listed here. Please contact your International Rectifier sales representative for further information.

Absolute Maximum Ratings

Absolute maximum ratings indicate sustained limits beyond which damage to the device may occur. All voltage parameters are absolute voltages referenced to COM, all currents are defined positive into any lead. The thermal resistance and power dissipation ratings are measured under board mounted and still air conditions.

Symbol	Definition	Min.	Max.	Units
VB	High-side floating supply absolute voltage	-0.3	625	V
VS	High-side floating supply offset voltage	VB - 25	VB + 0.3	
VHO	High-side floating output voltage	VS - 0.3	VB + 0.3	
VCC	Low-side output voltage	-0.3	25	
VLO	Low-side and logic fixed supply voltage	-0.3	VCC + 0.3	
VIN	Logic input voltage	VS - 0.3	VCC + 0.3	
VSS	Logic ground	VCC - 25	VCC + 0.3	V/ns
dV_S/dt	Allowable offset supply voltage transient	---	50	W
PD	Package power dissipation @ $T_A \leq +25\text{ }^\circ\text{C}$	---	1.0	
RthJA	Thermal resistance, junction to ambient	---	120	$^\circ\text{C}/\text{W}$
TJ	Junction temperature	---	150	$^\circ\text{C}$
TS	Storage temperature	-50	150	
TL	Lead temperature (soldering, 10 seconds)	---	300	

Recommended Operating Conditions

The input/output logic timing diagram is shown in Fig. 1. For proper operation the device should be used within the recommended conditions. The V_S and V_{SS} offset rating are tested with all supplies biased at a 15 V differential..

Symbol	Definition	Min.	Max.	Units
VB	High-side floating supply absolute voltage	$V_S + 10$	$V_S + 20$	V
VS	High-side floating supply offset voltage	Note 1	600	
VHO	High-side floating output voltage	V_S	VB	
VCC	Low-side output voltage		10	
VLO	Low-side and logic fixed supply voltage	0	VCC	
VIN	Logic input voltage	V_{SS}	VCC	
VSS	Logic ground	-5	5	
TA	Ambient temperature	-40	125	°C

- † Logic operational for VS of -5 V to +600 V. Logic state held for VS of -5 V to -VBS.
(Please refer to the Design Tip DT97-3 for more details).

Static Electrical Characteristics

V_{BIAS} (V_{CC} , V_{BS}) = 14 V, C_T = 1 nF and T_A = 25 °C unless otherwise specified. The V_O and I_O parameters are referenced to COM and are applicable to the respective output leads: HO or LO. $C_{LO1}=C_{LO2}=C_{HO1}=C_{HO2}=1$ nF.

Symbol	Definition	Min	Typ	Max	Units	Test Conditions
Low Voltage Supply Characteristics						
V_{IH}	Logic "1" input voltage	2.5	—	—	V	$V_{CC} = 10$ V to 20V
V_{IL}	Logic "0" input voltage	—	—	0.8		
V_{OH}	High level output voltage, $V_{BIAS} - V_O$	—	0.05	0.2		
V_{OL}	Low level output voltage, V_O	—	0.02	0.1		
I_{LK}	Offset supply leakage current	—	—	50	μ A	$V_B = V_S = 600$ V
I_{QBS}	Quiescent VBS supply current	20	75	130		$V_{IN} = 0$ V or 5V
I_{QCC}	Quiescent VCC supply current	60	120	180		
I_{IN+}	Logic "1" input bias current $V_{IN} = 5$ V	—	5	20		
I_{IN-}	Logic "0" input bias current $V_{IN} = 0$ V	—	—	5		
V_{CCUV+} V_{BSUV+}	VCC and VBS supply undervoltage positive going threshold	8.0	8.9	9.8	V	
V_{CCUV-} V_{BSUV-}	VCC and VBS supply undervoltage negative going threshold	7.4	8.2	9.0		
V_{CCUVH} V_{BSUVH}	Hysteresis	0.3	0.7	—		
I_{o+}	Output high short circuit pulsed current	130	290	—	mA	$V_O = 0$ V, $PW \leq 10$ μ s
I_{o-}	Output low short circuit pulsed current	270	600	—		$V_O = 15$ V, $PW \leq 10$ μ s

Dynamic Electrical Characteristics

V_{BIAS} (V_{CC} , V_{BS}) = 15 V, $V_{SS} = COM$, $C_L = 1000$ pF, $T_A = 25$ °C.

Symbol	Component	Min.	Typ.	Max.	Units	Test Conditions
t_{on}	Turn-on propagation delay	---	165	230	ns	$V_S = 0$ V
t_{off}	Turn-off propagation delay	---	165	230		$V_S = 0$ V or 600 V
MT	Delay matching, HS & LS turn-on/off	---	0	30		$V_S = 0$ V
t_r	Turn-on rise time	---	100	220		
t_f	Turn-off fall time	---	35	80		

Functional Block Diagram

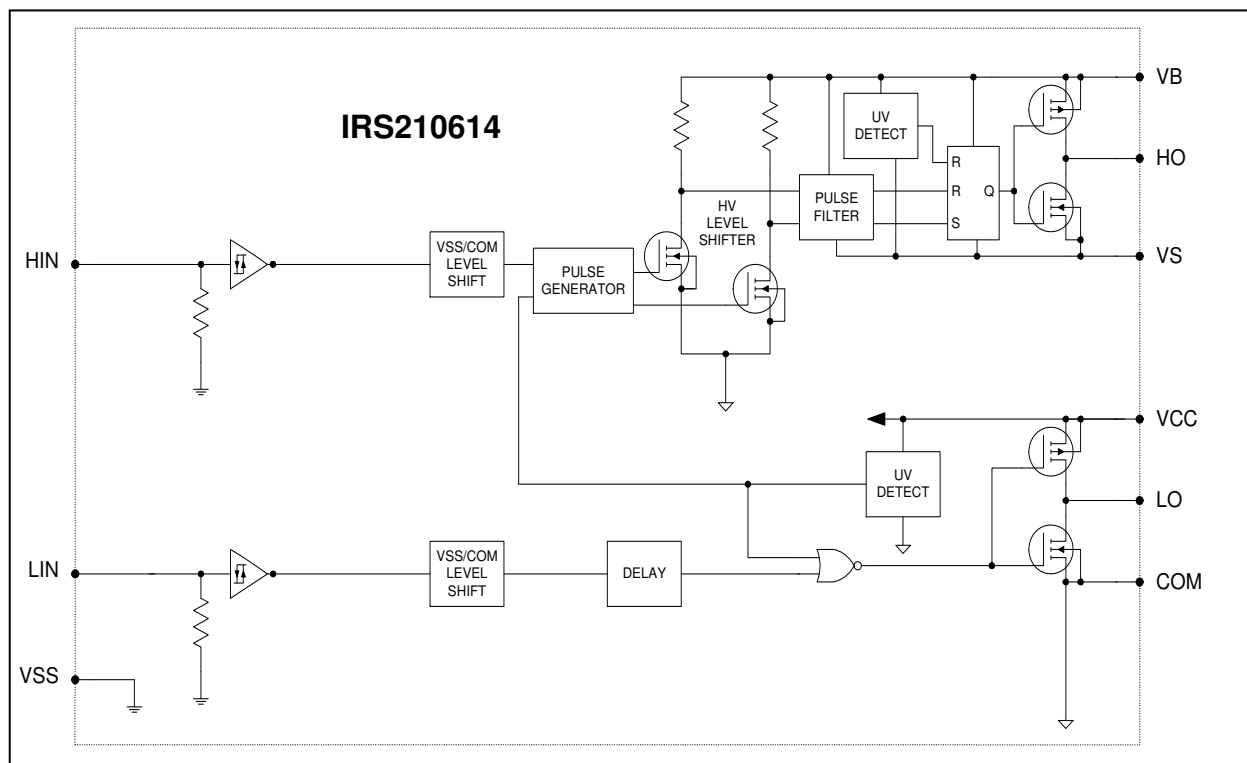

I/O Pin Equivalent Circuit Diagrams

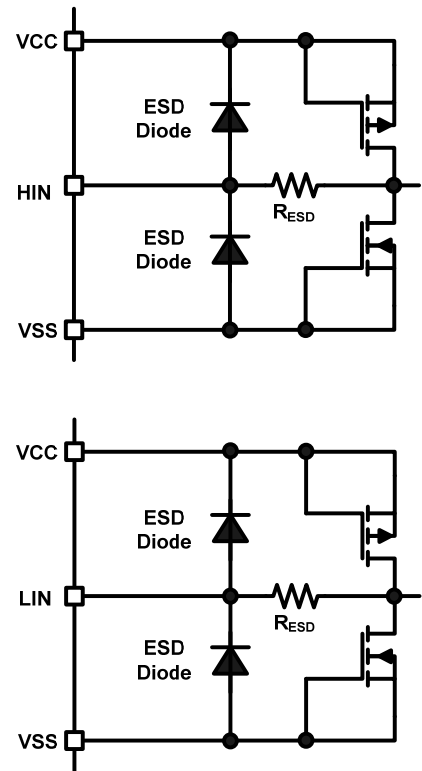
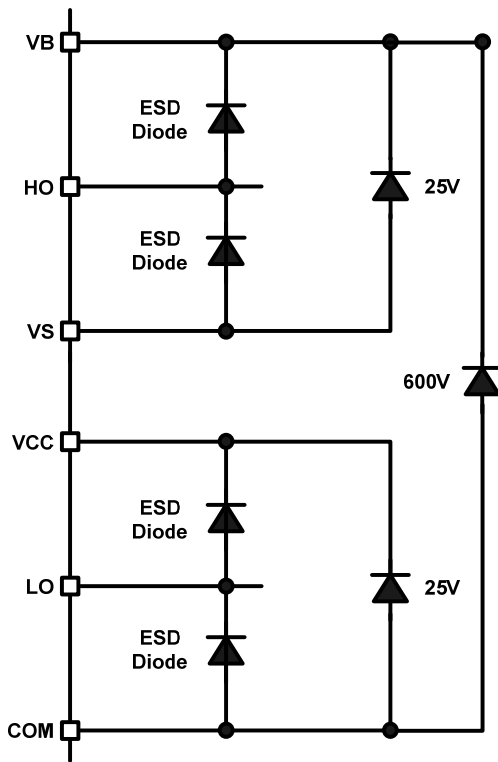

Lead Definitions

Pin#	Symbol	Description
1	V _{CC}	Low-side and logic fixed supply
2	HIN	Logic input for high-side gate driver output (HO), in phase
3	LIN	Logic input for low-side gate driver output (LO), in phase
4	NC	No Connect
5	V _{SS}	Logic ground
6	COM	Low-side return
7	LO	Low-side drive output
8	NC	No Connect
9	NC	No Connect
10	NC	No Connect
11	V _S	High-side floating supply return
12	HO	High-side gate drive output
13	V _B	High-side floating supply
14	NC	No Connect

Lead Assignments

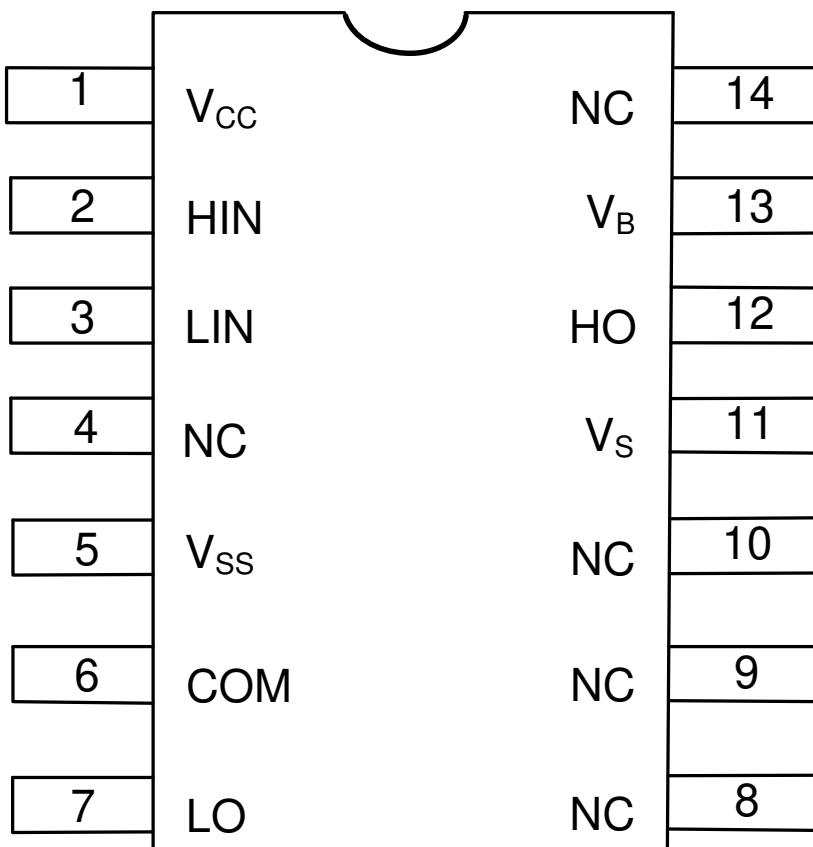

Waveform definitions

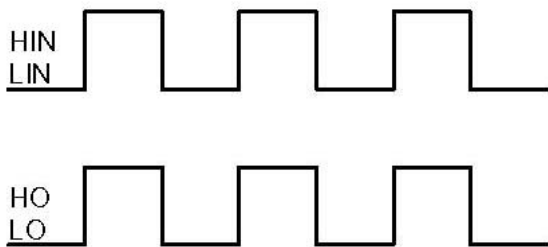

Figure 1. Input/Output Timing Diagram

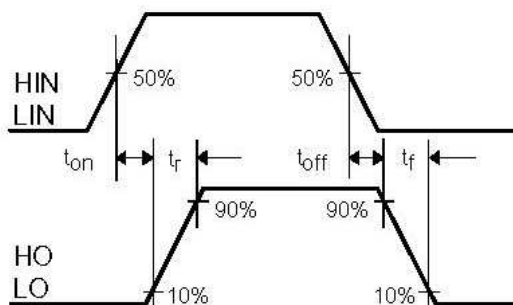

Figure 2. Switching Time Waveform Definitions

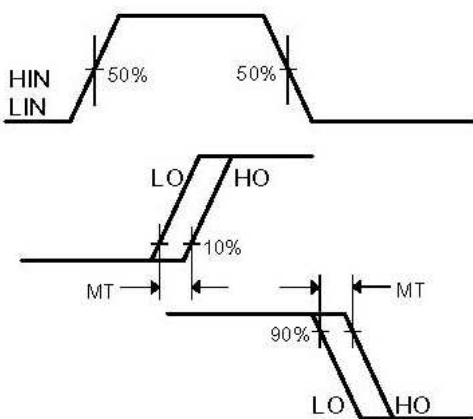
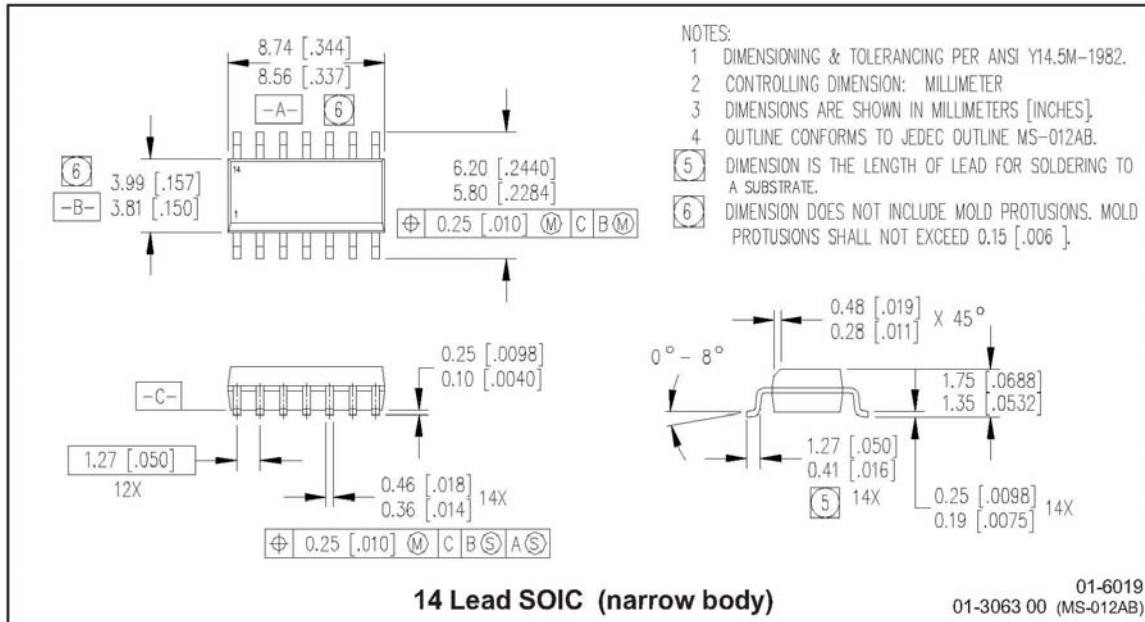
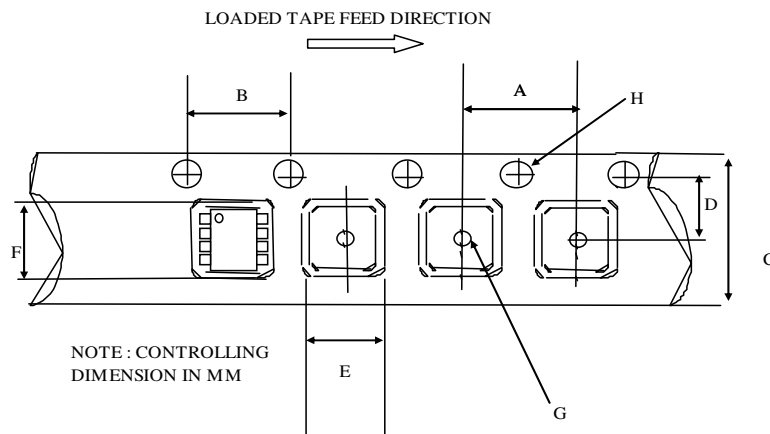

Figure 3. Delay Matching Waveform Definitions

Package Details: SO14N



Package Details: SOIC14N, Tape and Reel



CARRIER TAPE DIMENSION FOR 14SOICN

Code	Metric		Imperial	
	Min	Max	Min	Max
A	7.90	8.10	0.311	0.318
B	3.90	4.10	0.153	0.161
C	15.70	16.30	0.618	0.641
D	7.40	7.60	0.291	0.299
E	6.40	6.60	0.252	0.260
F	9.40	9.60	0.370	0.378
G	1.50	n/a	0.059	n/a
H	1.50	1.60	0.059	0.062

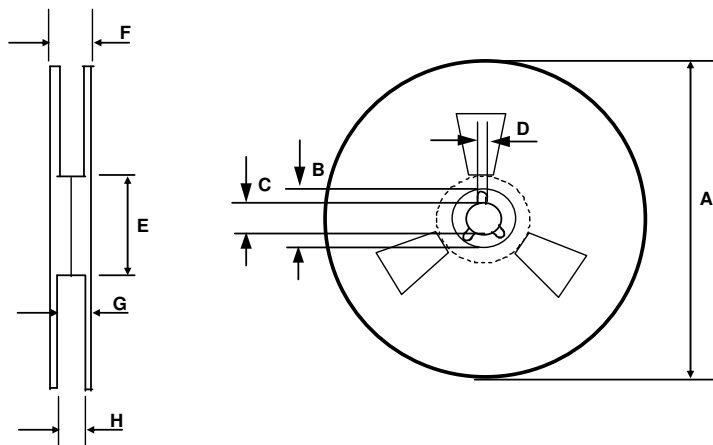

REEL DIMENSIONS FOR 14SOICN

Code	Metric		Imperial	
	Min	Max	Min	Max
A	329.60	330.25	12.976	13.001
B	20.95	21.45	0.824	0.844
C	12.80	13.20	0.503	0.519
D	1.95	2.45	0.767	0.096
E	98.00	102.00	3.858	4.015
F	n/a	22.40	n/a	0.881
G	18.50	21.10	0.728	0.830
H	16.40	18.40	0.645	0.724

Part Marking Information

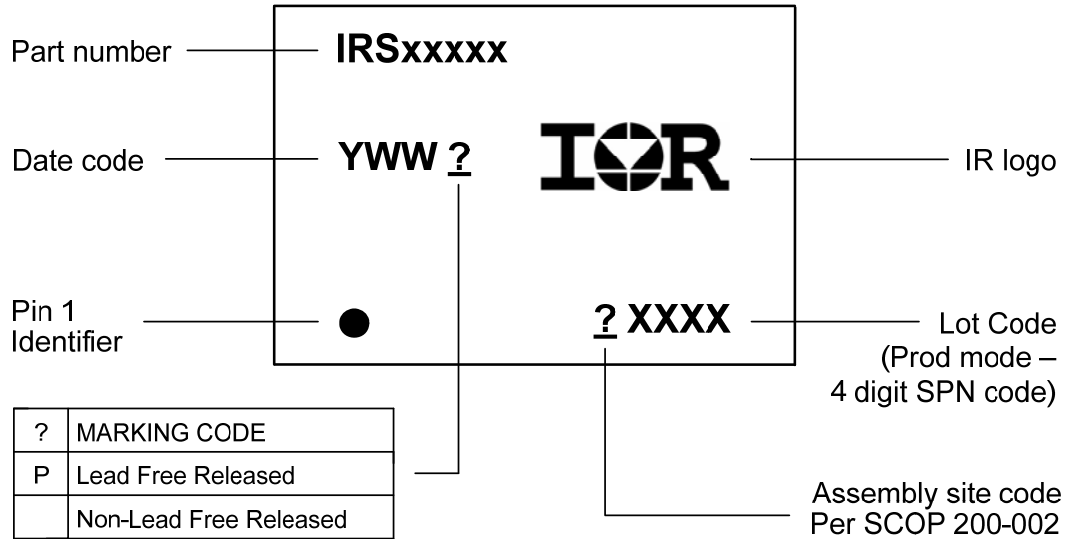

Ordering Information

Base Part Number	Package Type	Standard Pack		Complete Part Number
		Form	Quantity	
IRS210614S	SOIC14N	Tube/Bulk	55	IRS210614SPBF
		Tape and Reel	2500	IRS210614STRPBF

The information provided in this document is believed to be accurate and reliable. However, International Rectifier assumes no responsibility for the consequences of the use of this information. International Rectifier assumes no responsibility for any infringement of patents or of other rights of third parties which may result from the use of this information. No license is granted by implication or otherwise under any patent or patent rights of International Rectifier. The specifications mentioned in this document are subject to change without notice. This document supersedes and replaces all information previously supplied.

For technical support, please contact IR's Technical Assistance Center
<http://www.irf.com/technical-info/>

WORLD HEADQUARTERS:
 233 Kansas St., El Segundo, California 90245
 Tel: (310) 252-7105