



Chipsmall Limited consists of a professional team with an average of over 10 year of expertise in the distribution of electronic components. Based in Hongkong, we have already established firm and mutual-benefit business relationships with customers from,Europe,America and south Asia,supplying obsolete and hard-to-find components to meet their specific needs.

With the principle of “Quality Parts,Customers Priority,Honest Operation,and Considerate Service”,our business mainly focus on the distribution of electronic components. Line cards we deal with include Microchip,ALPS,ROHM,Xilinx,Pulse,ON,Everlight and Freescale. Main products comprise IC,Modules,Potentiometer,IC Socket,Relay,Connector.Our parts cover such applications as commercial,industrial, and automotives areas.

We are looking forward to setting up business relationship with you and hope to provide you with the best service and solution. Let us make a better world for our industry!



## Contact us

Tel: +86-755-8981 8866 Fax: +86-755-8427 6832

Email & Skype: info@chipsmall.com Web: www.chipsmall.com

Address: A1208, Overseas Decoration Building, #122 Zhenhua RD., Futian, Shenzhen, China



# End Of Life

## IC Features

- Dimming LED driver controller
- Hysteretic Current Regulation
- Closed-loop LED current dimming control
- Analog/PWM Dimming Input
- Internal High Voltage Regulator
- Internal 15.6V zener clamp diode on Vcc
- Micropower startup (250 $\mu$ A)
- Latch immunity and ESD protection

## LED Driver System Features

- Single chip dimming solution
- Simple LED current dimming control method
- No external protection circuits required (fully internal)
- Low external component count
- Easy to use for fast design cycle time
- Increased manufacturability and reliability

## Product Summary

Topology	Buck
V <sub>OFFSET</sub> (breakdown)	600 V
V <sub>OUT</sub>	V <sub>CC</sub>
I <sub>O+</sub> & I <sub>O-</sub> (typical)	180mA & 260mA

## Package Types

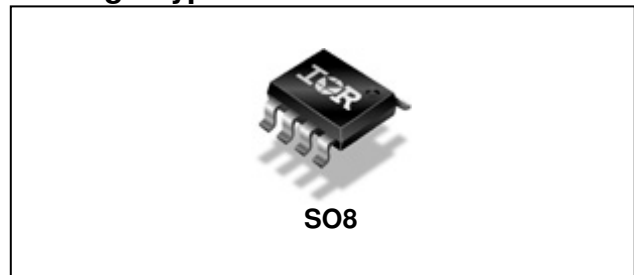

## Typical applications

- LED incandescent/CFL replacement lamps
- LED driver module

## Typical Connection Diagram

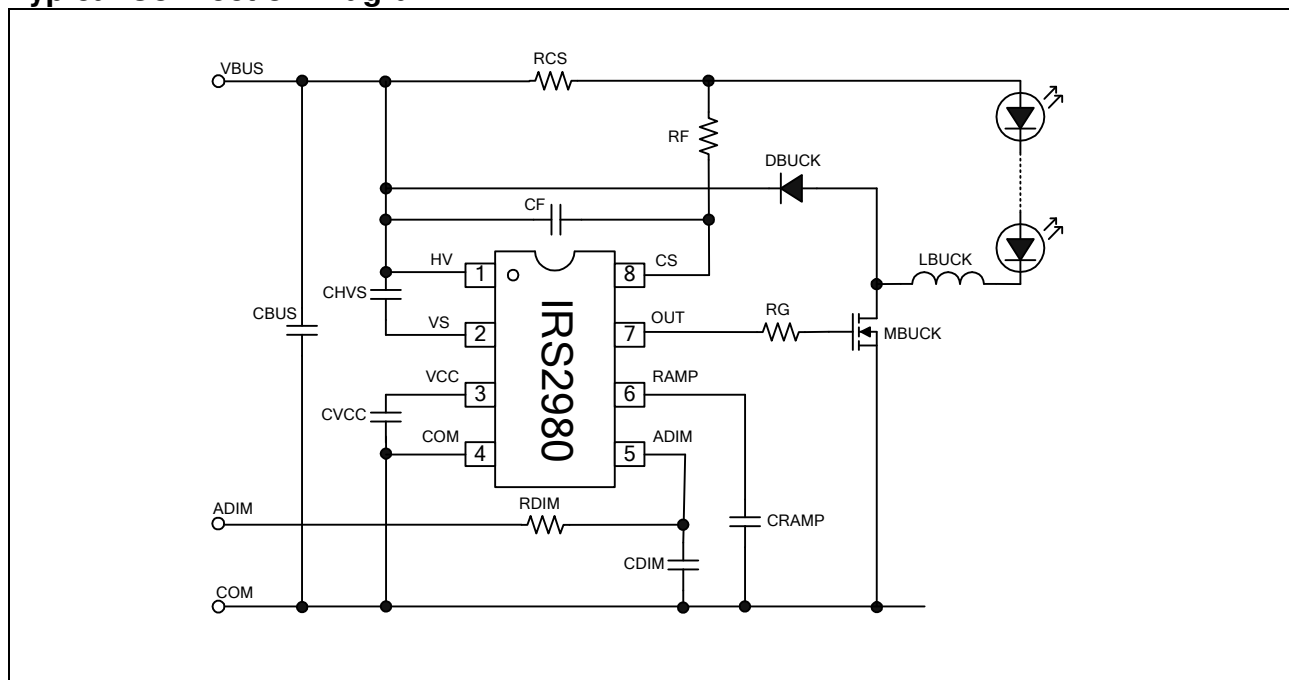

<b>Table of Contents</b>	<b>Page</b>
Description	3
Block Diagram	3
Qualification Information	4
Absolute Maximum Ratings	5
Recommended Operating Conditions	6
Electrical Characteristics	7
Input/Output Pin Equivalent Circuit Diagram	9
Lead Definitions	10
Lead Assignments	10
Application Information and Additional Details	11
Package Details	15
Tape and Reel Details	16
Part Marking Information	17
Ordering Information	18

## Description

The IRS2980S utilizes International Rectifier's control and high-voltage technologies to realize a simple, high-performance Buck LED driver solution. This solution is based on hysteretic output current regulation typically operating from 25 kHz to 120 kHz. Frequency and duty cycle vary to maintain a tightly regulated average output current over variations in line and load. Output current ripple will depend on inductor selection in conjunction with input and output voltages as well as output current and component selection. The IRS2980S uses a unique floating high side differential current sense and level shift scheme allowing hysteretic operation with a low side switching MOSFET optimizing size and cost. In addition, the IRS2980S includes a high voltage regulator able to operate up to 450V eliminating the need for an external VCC supply. A PWM dimming interface is also included that can be controlled from a 0 to 2V analog or 3.3 or 5V logic control signal able to operate up to 1kHz offering brightness control from 0 to 100%. A programmable on board PWM oscillator is used with DC dimming control.

## Block Diagram

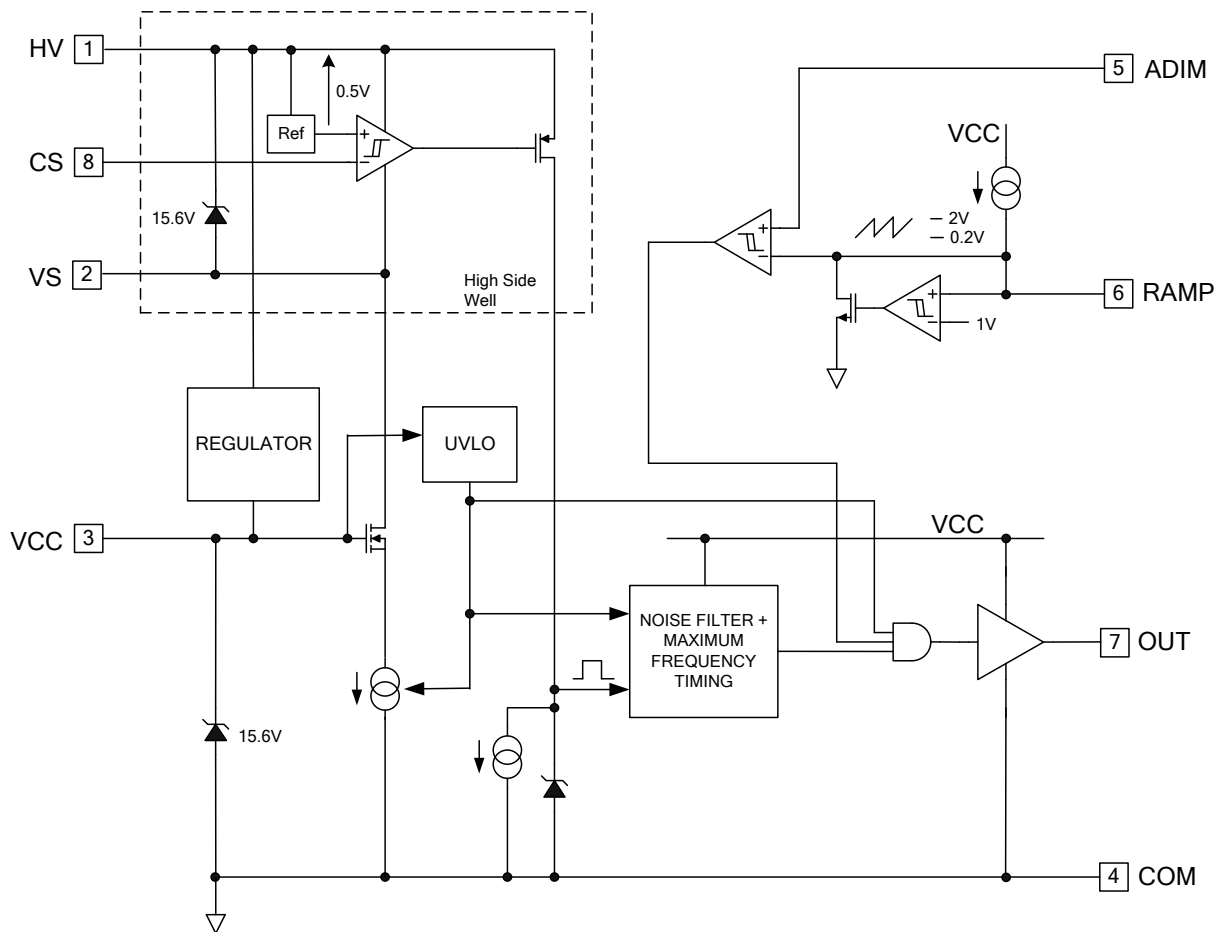

## Qualification Information<sup>†</sup>

<b>Qualification Level</b>		Industrial <sup>††</sup>
		Comments: This family of ICs has passed JEDEC's Industrial qualification. IR's Consumer qualification level is granted by extension of the higher Industrial level.
<b>Moisture Sensitivity Level</b>		MSL2 <sup>†††</sup> (per IPC/JEDEC J-STD-020C)
ESD	Machine Model	Class B (per JEDEC standard JESD22-A115)
	Human Body Model	Class 2 (per EIA/JEDEC standard EIA/JESD22-A114)
IC Latch-Up Test		Class I, Level A (per JESD78)
<b>RoHS Compliant</b>		Yes

† Qualification standards can be found at International Rectifier's web site <http://www.irf.com/>

†† Higher qualification ratings may be available should the user have such requirements. Please contact your International Rectifier sales representative for further information.

††† Higher MSL ratings may be available for the specific package types listed here. Please contact your International Rectifier sales representative for further information.

## Absolute Maximum Ratings

Absolute Maximum Ratings indicate sustained limits beyond which damage to the device may occur. All voltage parameters are absolute voltages referenced to COM; all currents are defined positive into any lead. The Thermal Resistance and Power Dissipation ratings are measured under board mounted and still air conditions.

Symbol	Definition	Min.	Max.	Units
VHV	High Voltage Input <sup>†</sup>	-0.3	450	V
VOUT	Low-Side Output Voltage	-0.3	VCC + 0.3	
VADIM	DIM Input Voltage	-0.3	VCC + 0.3	
VRAMP	RAMP Input Voltage	-0.3	VCC + 0.3	
ICC	Supply Current <sup>††</sup>	---	20	mA
IOMAX	Maximum allowable current at OUT due to external power transistor Miller effect.	-500	500	
PD	Maximum Power Dissipation @ TA ≤ +25°C <sup>†††</sup>	---	0.625	W
RθJA	Thermal Resistance, Junction to Ambient	---	128	°C/W
TJ	Junction Temperature	-55	150	°C
TS	Storage Temperature	-55	150	
TL	Lead Temperature (Soldering, 10 seconds)	---	300	

† The IRS2980S uses an HVIC process capable of withstanding up to 600V, however the internal regulator maximum input voltage rating is limited to 450V maximum due to package power dissipation. The device can withstand transient voltages up to 600V for short periods.

†† This IC contains a zener clamp structure between the chip VCC and COM which has a nominal breakdown voltage of 15.6V. This supply pin should not be driven by a DC, low impedance power source greater than the VCLAMP specified in the Electrical Characteristics section.

††† Power dissipation is dependent on VHV and switching frequency. In order to limit device temperature rise some thermal relief may be required in the form of copper on the PCB located under and around the device. Alternatively a small heat sink may be attached to the top of the device. Thermally conductive potting compounds can also provide excellent heat transfer.

## Recommended Operating Conditions

For proper operation the device should be used within the recommended conditions.

Symbol	Definition	Min.	Max.	Units
VHV	High Voltage Input <sup>†</sup>	0	375	V
VCC	Supply Voltage	10.0	VCLAMP	
ICC	Supply Current	---	5	mA
VRAMP	VENN Pin Voltage	0	6	V
VADIM	VENN Pin Voltage	0	6	V
VENN	VENN Pin Voltage	0	6	V
TJ	Junction Temperature	-40	125	°C

† Operation above this voltage level and below 450V is possible with sufficient heat sinking.

## Electrical Characteristics

VHV=100V, VCC=14V, CVCC=0.1μF, CHVS=22nF, and TA = 25°C unless otherwise specified. The output voltage and current (VO and IO) parameters are referenced to COM and are applicable to OUT.

Symbol	Definition	Min	Typ	Max	Units	Test Conditions
<b>Low Voltage Supply Characteristics</b>						
V <sub>CLAMP</sub>	V <sub>CC</sub> Zener Clamp Voltage	14.6	15.6	16.6	V	I <sub>CC</sub> = 10mA
I <sub>QCCUV</sub>	Micropower Startup V <sub>CC</sub> Supply Current	---	250	---	μA	V <sub>CC</sub> = 6V
<b>High Voltage Regulator Characteristics</b>						
V <sub>CCREG</sub>	V <sub>CC</sub> Regulation Voltage	8.9	9.9	10.9	V	I <sub>CC</sub> = 1mA
I <sub>REG_MAX</sub>	Maximum Regulator Current	---	3	5	mA	V <sub>CC</sub> = 0V
V <sub>HVMIN</sub>	Minimum HV required for regulator <sup>†</sup>	---	60	---	V	
<b>High Side Voltage Supply Characteristics</b>						
V <sub>HVS+</sub>	High Side UVLO Positive Threshold	8.3	9.3	10.3	V	
V <sub>HVS-</sub>	High Side UVLO Negative Threshold	6.3	7.3	8.3		
<b>Control Characteristics</b>						
f <sub>MAX</sub>	Maximum Output Frequency	---	150	---	kHz	
d <sub>MAX</sub>	Buck Duty Cycle	---	100	---	%	
V <sub>CS</sub>	Current Regulation Threshold <sup>††</sup>	---	0.5	---	V	
V <sub>CS-HYS</sub>	Current Regulation Hysteresis	---	100	---	mV	
<b>Dimming Characteristics</b>						
I <sub>RAMP</sub>	RAMP Pin Charging Current	---	15	---	μA	
V <sub>RAMP+</sub>	RAMP Pin Shutdown Threshold	---	2.0	---		
V <sub>RAMP-</sub>	RAMP Pin Re-start Threshold	---	0.2	---		
d <sub>PWM</sub>	Dimming Duty Cycle	0		100	%	

† V<sub>CC</sub> can be supplied from an alternative source for the IRS2980S to operate with bus voltages below this level.

†† Various tolerances on V<sub>CS</sub> are available upon request



## Electrical Characteristics

VHV=100V, VCC= 14V, CVCC=0.1 $\mu$ F, CHVS=22nF and TA = 25°C unless otherwise specified. The output voltage and current (VO and IO) parameters are referenced to COM and are applicable to OUT.

Symbol	Definition	Min	Typ	Max	Units	Test Conditions
<b>Gate Driver Output Characteristics (OUT)</b>						
V <sub>OH</sub>	High-Level Output Voltage	---	VCC	---		I <sub>O</sub> = 0A
V <sub>OL</sub>	Low-Level Output Voltage	---	COM	---		I <sub>O</sub> = 0A
V <sub>OL_UV</sub>	UV-Mode Output Voltage	---	COM	---		I <sub>O</sub> = 0A, V <sub>CC</sub> ≤ 8.0V
t <sub>r</sub>	Output Rise Time	---	120	220	ns	
t <sub>f</sub>	Output Fall Time	---	50	80		
I <sub>O+</sub>	Output source current	---	180	---	mA	
I <sub>O-</sub>	Output sink current	---	260	---		

**I/O Pin Equivalent Circuit Diagrams**

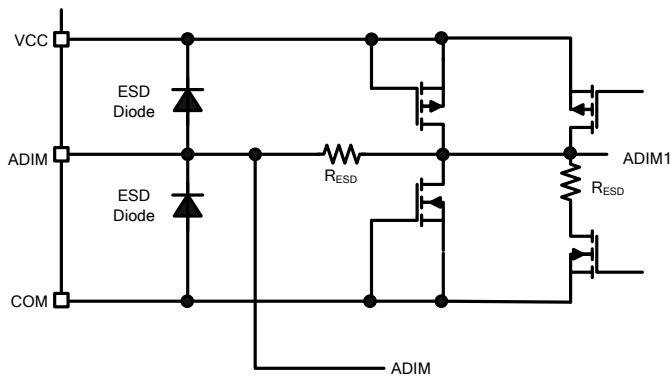
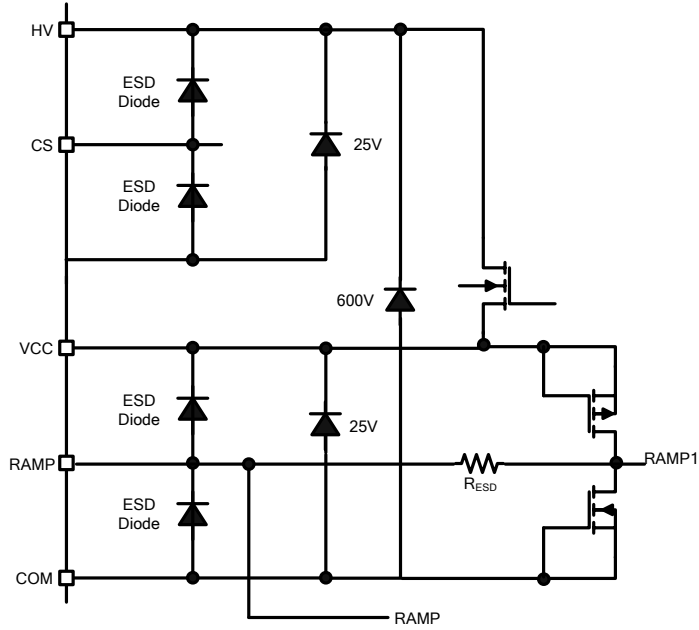

## Lead Definitions

Pin #	Symbol	Description
1	HV	High Voltage Bus
2	VS	High Side Floating Supply Return
3	VCC	VCC Supply
4	COM	Ground / Common
5	ADIM	Linear / Analog Dimming Input
6	RAMP	Ramp Waveform for Analog Dimming
7	OUT	Gate Drive Output
8	CS	Load Current Sense

## Lead Assignments

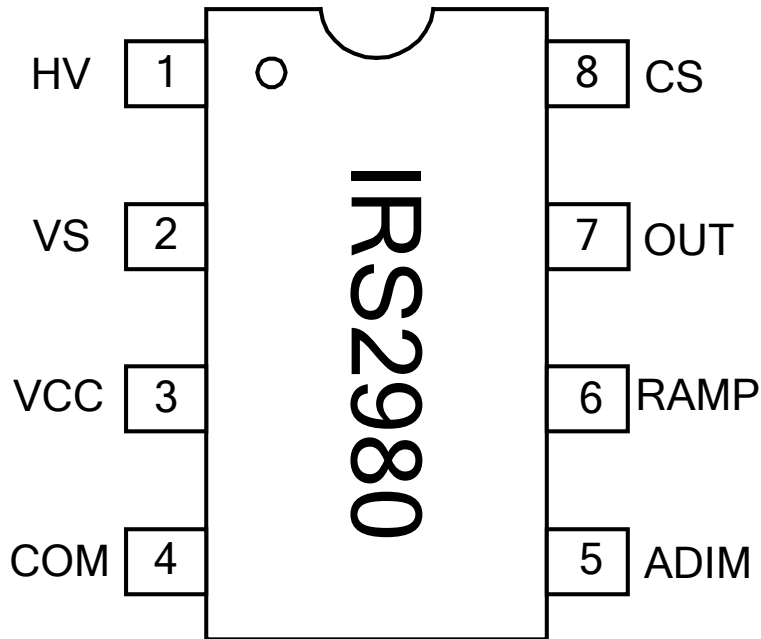

## Application Information and Additional Details

The IRS2980S is primarily intended for use in Buck LED drivers operating with average current regulation using hysteretic control. The circuit topology uses a low side MOSFET referenced to the 0V bus driven by a low side gate driver circuit within the IRS2980S and an additional fast recovery freewheeling diode. In order to minimize switching losses the reverse recovery time of this diode should be no more than 35nS. The MOSFET should be selected for low capacitance to reduce switching losses and low gate charge (less than 25nC is recommended) to minimize gate drive current. The LED load is referenced to the DC bus and not 0V. The IRS2980S incorporates floating high side current sense inputs allowing the LED current to be sensed both when the MOSFET is switched on and off. This enables hysteretic operation, switching the MOSFET off when the current rises above an upper threshold and off when the current falls below a lower threshold.

The current sense threshold  $V_{CS}$  is nominally 500mV with approximately 100mV of hysteresis making the upper limit  $V_{CS}+50mV$  and the lower limit  $V_{CS}-50mV$ . Some overshoot typically occurs due to propagation delays and a small undershoot is also possible. These vary depending on di/dt of the ripple current, which is a function of input and output voltage, inductor value and frequency as well as RC filter values ( $R_F$  and  $C_F$ ). The average current is maintained at approximately the mid-point over a wide input and output voltage range due to the inherent accuracy of hysteretic control. The LED output current is set by selecting the value of the current sense resistor RCS. This is determined by the formula:

$$R_{CS} = \frac{V_{CS}}{I_{LED}}$$

Where,  $I_{LED}$  is the average LED output current.

The peak to peak ripple  $\Delta I_{LED}$  will be 20% of the average LED current  $I_{LED}$  due to the hysteretic operation plus some additional ripple due to circuit delays. These are caused mainly by the current sense filter and MOSFET gate drive.

Since the IRS2980S uses hysteretic current control to switch the Buck MOSFET on and off, the LED current (which is equal to the inductor current) is maintained between upper and lower thresholds. Because of this the switching frequency and duty cycle vary to meet the

operating conditions imposed by the input and output voltages, output current and inductor value.

The following diagram shows the rise and fall of the LED current as the MOSFET switches on and off:

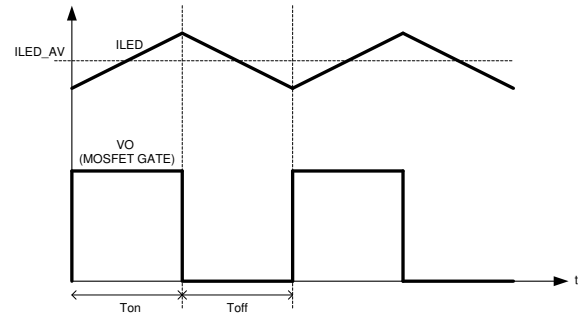

Figure 1: MOSFET gate drive and inductor/LED current.

The following formulae model the operation of the IRS2980S based Buck LED driver:

$$t_{on} \approx \frac{0.2 \cdot L \cdot I_{LED}}{V_{BUS\_DC} - V_{LED}} + R_F \cdot C_F + \frac{Q_G}{0.18} + t_{dr}$$

$$t_{off} \approx \frac{0.2 \cdot L \cdot I_{LED}}{V_{LED}} + R_F \cdot C_F + \frac{Q_G}{0.26} + t_{df}$$

$$f_{SW} = \frac{1}{t_{on} + t_{off}} \quad (\text{switching frequency})$$

$$d = \frac{t_{on}}{t_{on} + t_{off}} \quad (\text{duty cycle})$$

Where,

$R_F$  and  $C_F$  are the current sense filter components,

$L$  is the inductor value,

$Q_G$  is the MOSFET gate charge,

$t_{dr}$  and  $t_{df}$  are propagation delays

(These values vary depending on circuit conditions,  $t_{dr}$  decreases with input voltage.  $t_{df}$  is normally negligible. For a first order approximation these terms may be ignored.)

Operating frequency and duty cycle will vary when there is ripple in the DC bus voltage. For example where a passive valley fill circuit is used for power factor correction (PFC) the LED current will be regulated dynamically by constantly changing frequency and duty cycle to maintain a constant average.

### Current Sense Filter Selection

The recommended values for  $R_F$  and  $C_F$  are 100Ohms and 1nF. This is sufficient to prevent instability due to switching noise appearing at the current sense input. These values have negligible effect on the frequency and ripple. In a test application using a 3.3mH inductor to drive a 17.5V LED panel, the output current varied from 338mA to 347mA (2.7%) over a DC voltage input range of 40V to 200V.

A resistor ( $R_G$ ) between the gate driver output and the gate of the power MOSFETs is also recommended to reduce switching transients by reducing  $dv/dt$ . A value of 100Ohms is recommended, however this can be increased to reduce noise if required.

Filter values may be increased in order to lower the running frequency without increasing inductor size. This results in higher current ripple and higher current change over input voltage variations. This may be an acceptable compromise depending on the application specification.

### Frequency Limiter

The switching frequency of the IRS2980S is internally limited to approximately 150 kHz ( $f_{MAX}$ ). The IRS2980S is designed for use below this frequency in order to limit current consumption in the VCC and floating high side bias supplies. This is necessary because the IRS2980S uses internal regulators to supply these voltages, which can supply only a limited current. This restriction is acceptable in most LED driver applications. Where higher frequency operation is needed the IRS25401/11 is recommended.

### High Voltage Regulator

The IRS2980S includes a high voltage regulator to supply VCC from the DC input bus voltage. This eliminates the need for external VCC supply circuitry. A VCC capacitor of 1uF is recommended for reliable startup and smooth operation. The IRS2980S may shut down if CVCC is not present or too small.

If necessary the internal regulator may also be bypassed by supplying an external DC supply from 14V to 15V to the VCC pin. Although the HV

pin of the IRS2980S is rated up to 450V, the actual maximum voltage that can be applied is limited by the by the power dissipation of the IC. The internal VCC regulator is recommended for use up to 200VDC or with a passive valley fill PFC circuit operating from up to 250VAC input. It can be operated at higher voltages only with sufficient heat sinking.

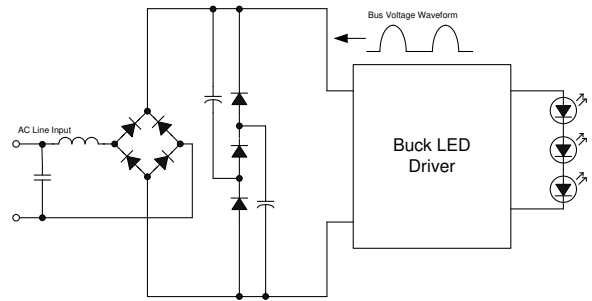

Figure 2: Passive valley fill PFC circuit

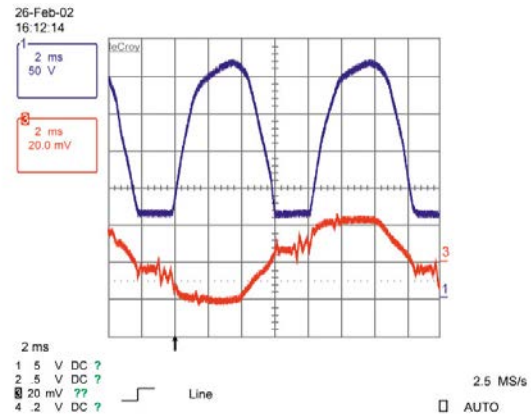

Figure 3: Passive valley fill PFC bus voltage (blue) and line input current (red) waveforms.

The VCC current ( $I_{CC}$ ) drawn by the IRS2980S can be estimated from the following formula:

$$I_{CC} \approx 1mA + Q_G \cdot f_{SW}$$

Therefore power dissipation due to the high voltage regulator can be calculated as:

$$P_{REG} = V_{BUS\_DC\_AV} \cdot I_{CC}$$

### Floating Differential Current Sense

The floating high side current sense incorporated in the IRS2980S is able to operate up to 450V and withstand voltage surges up to 600V. An internal bias supply is derived between the HV and VS

pins by a 1mA current source pulling down on VS so that a supply voltage is produced across the external capacitor CHVS to supply the high side circuitry. A value of 22nF is recommended for CHVS. The internal bias supply also dissipates some power, which can be calculated from the formula:

$$P_{BIAS} = (V_{BUS\_DC\_AV} - 10) \cdot 1mA$$

In order for the high side current sense circuitry to function, a minimum bus voltage of 30V is required to provide adequate bias supply current and standoff voltage.

### Thermal Considerations

Since the IRS2980S dissipates some power during normal operation, temperature rise of the IC die must be considered as part of the design process.

The SO8 IC package has a maximum power rating (PD) of 625mW, therefore the sum of  $P_{REG}$  and  $P_{BIAS}$  should not exceed this value.

The junction temperature should remain below 125°C to ensure operation within specifications.

The junction temperature is normally 10°C above the case temperature for an SO8 package therefore the case temperature should not exceed 115°C at maximum ambient.

The junction to ambient thermal resistance of the package ( $R\theta JA$ ) is 128°C/W. This would give an 80°C temperature rise without any thermal relief at the maximum PD value of 625mW.

$$\Delta T = PD \cdot R\theta JA$$

In order to reduce the junction temperature rise thermal relief should be added around the IRS2980S on the PCB. With adequate thermal relief the die temperature rise can be greatly reduced. The recommended method is to place an area of copper on the opposite side of the PCB to the IC in the same position with several vias added underneath the IC to conduct heat through to the other side.

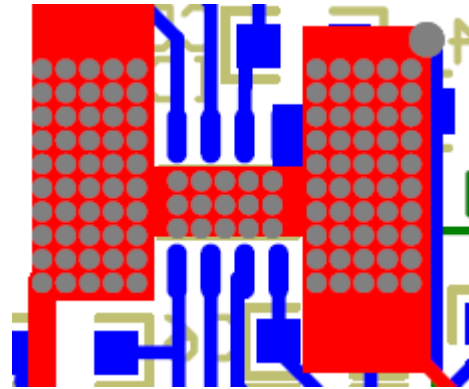

Figure 4: Thermal relief example

In addition if the IRS2980S is used in an application where the circuit is encapsulated in thermally conductive filler the die temperature rise is also greatly reduced.

Figure 4 shows an example of thermal relief placed around the IRS2980S in a high voltage application. The top side copper layer is shown as red and the bottom side is blue.

With thermal relief  $\Delta T$  becomes:

$$\Delta T = PD \cdot \left[ \frac{R\theta JA \cdot R\theta HS}{R\theta JA + R\theta HS} \right]$$

Where  $R\theta HS$  is the thermal resistance of the thermal relief area or heat sink, which will normally be lower than  $R\theta JA$ .

### Dimming

The IRS2980S includes a PWM dimming oscillator that generates a linear ramp waveform at the RAMP pin with the frequency determined by an external capacitor to COM (CRAMP). A DC voltage is applied to the ADIM pin which is compared to this ramp to produce a gating signal that enables and disables the high frequency switching of the MOSFET gate drive. By varying the ADIM voltage the duty cycle is adjusted allowing brightness to be adjusted from zero to 100%. This is accomplished by operating the LED driver in burst mode and varying the duty cycle of the bursts. The LED current during dimming is shown in figure 5:

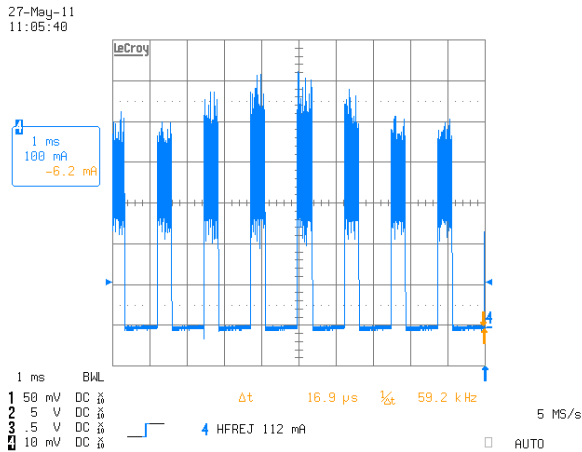

Figure 5: LED current during dimming.

The dimming level can also be controlled from a digital input by replacing CRAMP with a 68k resistor. This sets a DC threshold at the RAMP pin to approximately 1V so that a logic level PWM dimming control signal can be applied to the ADIM pin to directly switch the output on and off.

### PCB Layout Guidelines

Proper care should be taken when laying out a PCB board ensure correct functionality of the IRS2980S. Transients caused by high  $dV/dt$  during switching could potentially cause some false triggering of the hysteretic circuit therefore a small filter comprising RF and CF is recommended. CF should be located close to the IC pins with the trace from HV to RCS and the traces from RCS to CS through RF kept as short as possible. The 0V load return power ground should be connected to the IC COM pin and at a single point to avoid ground loops. The values of RF and CF are normally chosen to provide noise filtering without adding excessive delay to the circuit, however in some case these are deliberately made larger to lower the running frequency as this reduces switching losses and ICC current.

The following guidelines should be followed during PCB board layout:

- 1) Place VCC supply decoupling capacitor (CVCC) as close as possible to the VCC and COM pins.
- 2) Place high side decoupling capacitor (CVF) as close as possible to the HV and VS pins.
- 3) If the IRS2980S is being used in non-dimming mode connect the ADIM pin to VCC. If it is

being used in dim mode place a capacitor CDIM from the ADIM pin to COM and keep the capacitor as close to the IC as possible with the shortest possible traces.

- 4) If the IRS2980S is being used in non-dimming mode the RAMP pin can be connected to COM. If it is being used in dimming mode CRAMP should be located close to the IC with the shortest possible traces to the RAMP pin and COM.
- 5) Connect IC COM to power GND at one connection only. Do NOT route power GND through the programming components or IC COM.

## Package Details

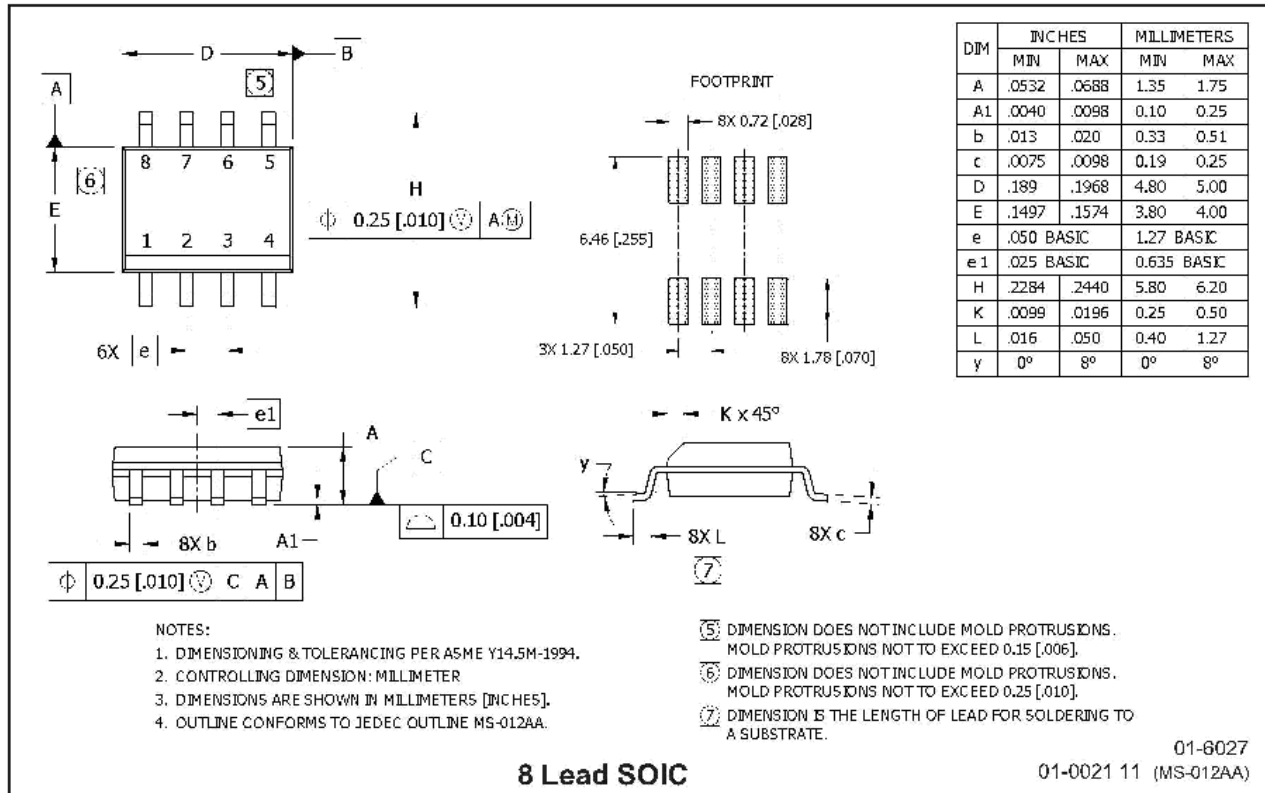



## Tape and Reel Details

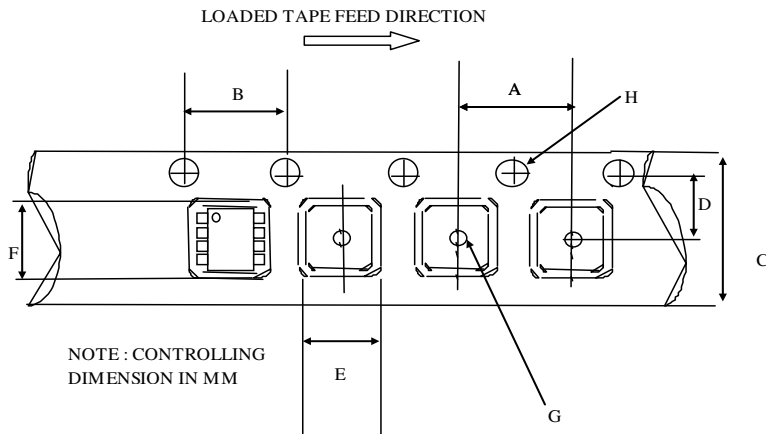

CARRIER TAPE DIMENSION FOR 8SOICN

Code	Metric		Imperial	
	Min	Max	Min	Max
A	7.90	8.10	0.311	0.318
B	3.90	4.10	0.153	0.161
C	11.70	12.30	0.46	0.484
D	5.45	5.55	0.214	0.218
E	6.30	6.50	0.248	0.255
F	5.10	5.30	0.200	0.208
G	1.50	n/a	0.059	n/a
H	1.50	1.60	0.059	0.062

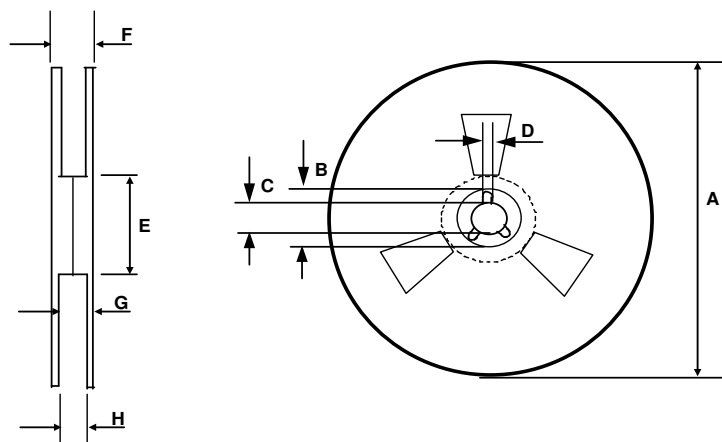

REEL DIMENSIONS FOR 8SOICN

Code	Metric		Imperial	
	Min	Max	Min	Max
A	329.60	330.25	12.976	13.001
B	20.95	21.45	0.824	0.844
C	12.80	13.20	0.503	0.519
D	1.95	2.45	0.767	0.096
E	98.00	102.00	3.858	4.015
F	n/a	18.40	n/a	0.724
G	14.50	17.10	0.570	0.673
H	12.40	14.40	0.488	0.566



# End Of Life

## IRS2980S

### Part Marking Information

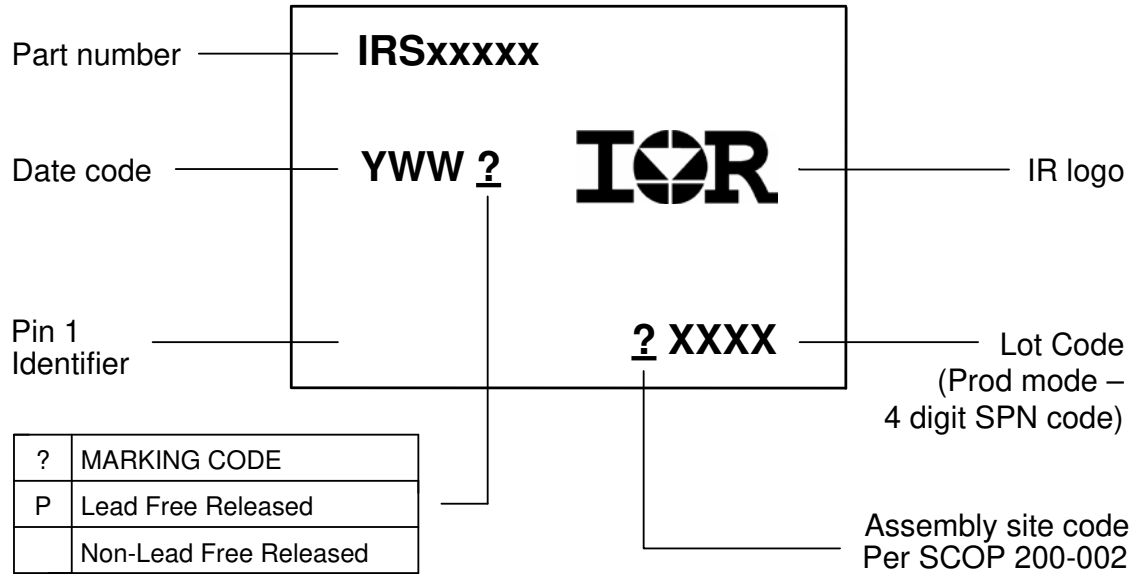

### Ordering Information

Base part number	Orderable part number	Package Type	Standard Pack		EOL Notice	Replacement Part Number
			Form	Quantity		
IRS2980S	IRS2980STRPbF	SOIC8N	Tape and Reel	2500	EOL301	<a href="#">Please search the EOL part number on IR's website for guidance</a>
	IRS2980SPbF	SOIC8N	Tube/Bulk	95		

### Revision History

Date	Comments
10/15/2015	<ul style="list-style-type: none"> <li>Added ordering information to reflect the End-Of-life</li> </ul>

The information provided in this document is believed to be accurate and reliable. However, International Rectifier assumes no responsibility for the consequences of the use of this information. International Rectifier assumes no responsibility for any infringement of patents or of other rights of third parties which may result from the use of this information. No license is granted by implication or otherwise under any patent or patent rights of International Rectifier. The specifications mentioned in this document are subject to change without notice. This document supersedes and replaces all information previously supplied.

For technical support, please contact IR's Technical Assistance Center  
<http://www.irf.com/technical-info/>

**WORLD HEADQUARTERS:**  
 233 Kansas St., El Segundo, California 90245  
 Tel: (310) 252-7105