



Chipsmall Limited consists of a professional team with an average of over 10 year of expertise in the distribution of electronic components. Based in Hongkong, we have already established firm and mutual-benefit business relationships with customers from,Europe,America and south Asia,supplying obsolete and hard-to-find components to meet their specific needs.

With the principle of “Quality Parts,Customers Priority,Honest Operation,and Considerate Service”,our business mainly focus on the distribution of electronic components. Line cards we deal with include Microchip,ALPS,ROHM,Xilinx,Pulse,ON,Everlight and Freescale. Main products comprise IC,Modules,Potentiometer,IC Socket,Relay,Connector.Our parts cover such applications as commercial,industrial, and automotives areas.

We are looking forward to setting up business relationship with you and hope to provide you with the best service and solution. Let us make a better world for our industry!



Contact us

Tel: +86-755-8981 8866 Fax: +86-755-8427 6832

Email & Skype: info@chipsmall.com Web: www.chipsmall.com

Address: A1208, Overseas Decoration Building, #122 Zhenhua RD., Futian, Shenzhen, China



**800mA LOW DROPOUT POSITIVE
 ADJUSTABLE REGULATOR**

FEATURES

- Guaranteed < 1.2V Dropout at 800mA Load Current
- Fast Transient Response
- 1% Voltage Reference Initial Accuracy
- Built-In Thermal Shutdown
- Available in SOT-223, D-Pak, Ultra Thin-Pak™ and 8-Pin SOIC Surface-Mount Packages

APPLICATIONS

- VGA & Sound Card Applications
- Low Voltage High Speed Termination Applications
- Standard 3.3V Chip Set and Logic Applications

DESCRIPTION

The IRU1117 is a low dropout, three-terminal adjustable regulator with minimum of 800mA output current capability. This product is specifically designed to provide well regulated supply for low voltage IC applications such as high speed bus termination and low current 3.3V logic supply. The IRU1117 is also well suited for other applications such as VGA and sound cards. The IRU1117 is guaranteed to have <1.2V dropout at full load current making it ideal to provide well regulated outputs of 2.5V to 3.6V with 4.75V to 7V input supply.

TYPICAL APPLICATION

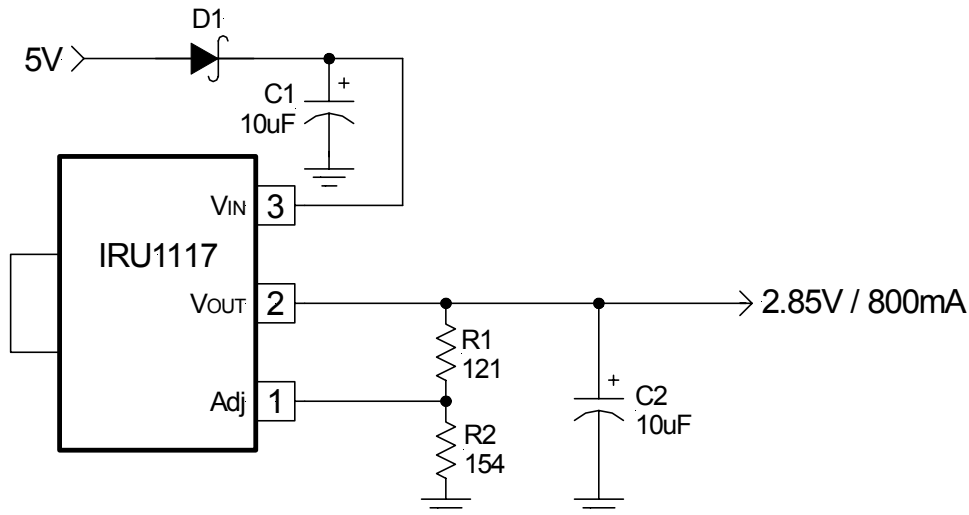

Figure 1 - Typical application of IRU1117 in a 5V to 2.85V SCSI termination regulator.

PACKAGE ORDER INFORMATION

Basic Part (Non-Lead Free)

T _J (°C)	2-PIN PLASTIC TO-252 (D-Pak)	2-PIN PLASTIC Ultra Thin-Pak™ (P)	8-PIN PLASTIC SOIC (S)	3-PIN PLASTIC SOT-223 (Y)
0 To 150	IRU1117CD	IRU1117CP	IRU1117CS	IRU1117CY

Leadfree Part

T _J (°C)	2-PIN PLASTIC TO-252 (D-Pak)	2-PIN PLASTIC Ultra Thin-Pak™ (P)	8-PIN PLASTIC SOIC (S)	3-PIN PLASTIC SOT-223 (Y)
0 To 150	Not available	Not available	IRU1117CSPbF	Not available

ABSOLUTE MAXIMUM RATINGS

Input Voltage (V_{IN})	7V
Power Dissipation	Internally Limited
Storage Temperature Range	-65°C To 150°C
Operating Junction Temperature Range	0°C To 150°C

PACKAGE INFORMATION

2-PIN PLASTIC TO-252 (D-Pak)	2-PIN ULTRA THIN-PAK™ (P)	8-PIN PLASTIC SOIC (S)	3-PIN PLASTIC SOT-223 (Y)
<p>$\theta_{JA}=70^{\circ}\text{C/W}$ for 0.5" Sq pad</p>	<p>$\theta_{JA}=70^{\circ}\text{C/W}$ for 0.5" Sq pad</p>	<p>$\theta_{JA}=55^{\circ}\text{C/W}$ for 1" Sq pad</p>	<p>$\theta_{JA}=90^{\circ}\text{C/W}$ for 0.4" Sq pad</p>

ELECTRICAL SPECIFICATIONS

Unless otherwise specified, these specifications apply over $C_{IN}=1\mu\text{F}$, $C_{OUT}=10\mu\text{F}$, and $T_J=0$ to 150°C . Typical values refer to $T_J=25^{\circ}\text{C}$.

PARAMETER	SYM	TEST CONDITION	MIN	TYP	MAX	UNITS
Reference Voltage	V_{REF}	$I_o=10\text{mA}$, $T_J=25^{\circ}\text{C}$, $(V_{IN}-V_o)=1.5\text{V}$ $I_o=10\text{mA}$, $(V_{IN}-V_o)=1.5\text{V}$	1.238 1.225	1.250 1.250	1.262 1.275	V
Line Regulation		$I_o=10\text{mA}$, $1.3\text{V}<(V_{IN}-V_o)<7\text{V}$			0.2	%
Load Regulation (Note 1)		$V_{IN}=3.3\text{V}$, $V_{ADJ}=0$, $10\text{mA}<I_o<800\text{mA}$			0.4	%
Dropout Voltage (Note 2)	ΔV_o	$I_o=1\text{A}$ $I_o=800\text{mA}$, Note 2		1.2 1.1	1.3 1.2	V
Current Limit		$V_{IN}=3.3\text{V}$, $\Delta V_o=100\text{mV}$	1.1			A
Minimum Load Current (Note 3)		$V_{IN}=3.3\text{V}$, $V_{ADJ}=0\text{V}$		5	10	mA
Thermal Regulation		30ms Pulse, $V_{IN}-V_o=3\text{V}$, $I_o=800\text{mA}$		0.01	0.02	%/W
Ripple Rejection		$f=120\text{Hz}$, $C_o=25\mu\text{F}$ Tantalum, $I_o=0.5\text{A}$, $V_{IN}-V_o=3\text{V}$	60	70		dB
Adjust Pin Current	I_{ADJ}	$I_o=10\text{mA}$, $V_{IN}-V_o=1.5\text{V}$, $T_J=25^{\circ}\text{C}$, $I_o=10\text{mA}$, $V_{IN}-V_o=1.5\text{V}$		55	120	μA
Adjust Pin Current Change		$I_o=10\text{mA}$, $V_{IN}-V_o=1.5\text{V}$, $T_J=25^{\circ}\text{C}$		0.2	5	μA
Temperature Stability		$V_{IN}=3.3\text{V}$, $V_{ADJ}=0\text{V}$, $I_o=10\text{mA}$		0.5		%
Long Term Stability		$T_J=125^{\circ}\text{C}$, 1000Hrs		0.3	1	%
RMS Output Noise		$T_J=25^{\circ}\text{C}$, $10\text{Hz}<f<10\text{KHz}$		0.003		$\%V_o$

Note 1: Low duty cycle pulse testing with Kelvin connections is required in order to maintain accurate data.

Note 2: Dropout voltage is defined as the minimum differential voltage between V_{IN} and V_{OUT} required to maintain regulation at V_{OUT} . It is measured when the output voltage drops 1% below its nominal value.

Note 3: Minimum load current is defined as the minimum current required at the output in order for the output voltage to maintain regulation. Typically, the resistor dividers are selected such that it automatically maintains this current. Typically, the values of the resistors used to build the voltage divider are selected to ensure that minimum load current is maintained.

PIN DESCRIPTIONS

PIN #	PIN SYMBOL	PIN DESCRIPTION
1	Adj	A resistor divider from this pin to the V _{OUT} pin and ground sets the output voltage.
2	V _{OUT}	The output of the regulator. A minimum of 10μF capacitor must be connected from this pin to ground to insure stability.
3	V _{IN}	The input pin of the regulator. Typically a large storage capacitor is connected from this pin to ground to insure that the input voltage does not sag below the minimum dropout voltage during the load transient response. This pin must always be 1.3V higher than V _{OUT} in order for the device to regulate properly.

BLOCK DIAGRAM

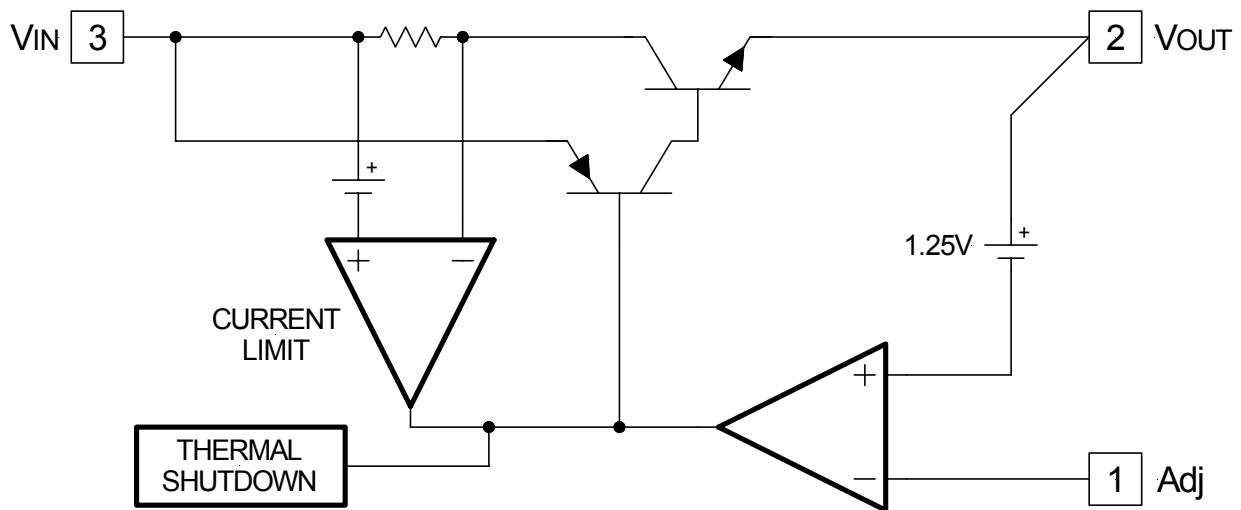

Figure 2 - Simplified block diagram of the IRU1117.

APPLICATION INFORMATION

Introduction

The IRU1117 adjustable Low Dropout (LDO) regulator is a three-terminal device which can easily be programmed with the addition of two external resistors to any voltages within the range of 1.25 to 5.5V. This regulator only needs 1.3V differential to maintain output regulation. Unlike the first generation of the three-terminal regulators such as LM117 that required 3V differential between the input and the regulated output.

The IRU1117 is specifically designed to meet the fast current transient needs as well as providing an accurate

initial voltage, reducing the overall system cost with the need for fewer output capacitors. This is a key requirement for today's low voltage IC applications that typically need 3.3V supply and are often generated from the 5V supply. Other applications such as high speed memory termination need to switch the load current from zero to full load in tens of nanoseconds at their pins, which translates to an approximately 300 to 500ns current step at the regulator. In addition, the output voltage tolerances are sometimes tight and they include the transient response as part of the specification.

Output Voltage Setting

The IRU1117 can be programmed to any voltages in the range of 1.25V to 5.5V with the addition of R1 and R2 external resistors according to the following formula:

$$V_{OUT} = V_{REF} \times \left(1 + \frac{R2}{R1}\right) + I_{ADJ} \times R2$$

Where:

$V_{REF} = 1.25V$ Typically

$I_{ADJ} = 50\mu A$ Typically

R1 and R2 as shown in Figure 3:

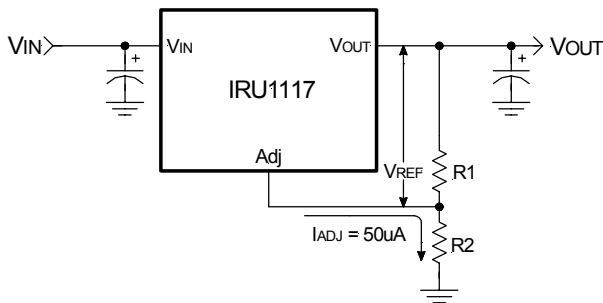

Figure 3 - Typical application of the IRU1117 for programming the output voltage.

The IRU1117 keeps a constant 1.25V between the output pin and the adjust pin. By placing a resistor R1 across these two pins a constant current flows through R1, adding to the I_{ADJ} current and into the R2 resistor producing a voltage equal to the $(1.25/R1) \times R2 + I_{ADJ} \times R2$ which will be added to the 1.25V to set the output voltage. This is summarized in the above equation. Since the minimum load current requirement of the IRU1117 is 10mA, R1 is typically selected to be 121Ω resistor so that it automatically satisfies the minimum current requirement. Notice that since I_{ADJ} is typically in the range of 50µA it only adds a small error to the output voltage and should only be considered when a very precise output voltage setting is required. For example, in a typical 3.3V application where $R1=121\Omega$ and $R2=200\Omega$ the error due to I_{ADJ} is only 0.3% of the nominal set point.

Load Regulation

Since the IRU1117 is only a three-terminal device, it is not possible to provide true remote sensing of the output voltage at the load. Figure 4 shows that the best load regulation is achieved when the bottom side of R2 is connected to the load and the top side of R1 resistor is connected directly to the case or the V_{OUT} pin of the regulator and not to the load. In fact, if R1 is connected

to the load side, the effective resistance between the regulator and the load is multiplied by the factor of $(1+R2/R1)$, or the effective resistance will be $R_{P(ef)}=R_P \times (1+R2/R1)$. It is important to note that for high current applications, this can represent a significant percentage of the overall load regulation and one must keep the path from the regulator to the load as short as possible to minimize this effect.

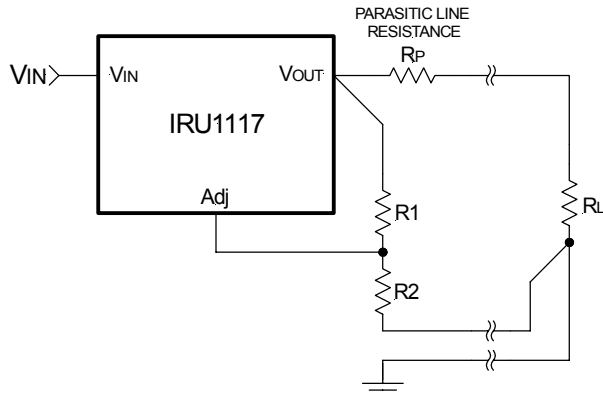

Figure 4 - Schematic showing connection for best load regulation.

Stability

The IRU1117 requires the use of an output capacitor as part of the frequency compensation in order to make the regulator stable. Typical designs for microprocessor applications use standard electrolytic capacitors with a typical ESR in the range of 50 to 100mΩ and an output capacitance of 500 to 1000µF. Fortunately as the capacitance increases, the ESR decreases resulting in a fixed RC time constant. The IRU1117 takes advantage of this phenomenon in making the overall regulator loop stable. For most applications a minimum of 100µF aluminum electrolytic capacitor such as Sanyo MVGX series, Panasonic FA series as well as the Nichicon PL series insures both stability and good transient response.

Thermal Design

The IRU1117 incorporates an internal thermal shutdown that protects the device when the junction temperature exceeds the maximum allowable junction temperature. Although this device can operate with junction temperatures in the range of 150°C, it is recommended that the heat sink be selected such that during maximum continuous load operation the junction temperature is kept below this number. The example below for a SCSI terminator application shows the steps in selecting the proper regulator in a surface-mount package. (See IRU1015 for non-surface-mount packages)

Assuming the following specifications:

$$\begin{aligned} V_{IN} &= 5V \\ V_F &= 0.5V \\ V_{OUT} &= 2.85V \\ I_{OUT(MAX)} &= 0.8A \\ T_A &= 35^\circ C \end{aligned}$$

Where:

V_F is the forward voltage drop of the D1 diode as shown in Figure 5.

+5V is significantly more than required to maintain drop-out voltage across the IRU1117 when regulating V_{OUT} to 2.85V. The "Extra" voltage means additional power is dissipated in the IRU1117. The diode dissipates some of this additional power, allowing the IRU1117 to run cooler.

The steps for selecting the right package with proper board area for heat sinking to keep the junction temperature below $135^\circ C$ is given as:

1) Calculate the maximum power dissipation using:

$$\begin{aligned} P_D &= I_{OUT} \times (V_{IN} - V_F - V_{OUT}) \\ P_D &= 0.8 \times (5 - 0.5 - 2.85) = 1.32W \end{aligned}$$

2) Calculate the maximum θ_{JA} allowed for our example:

$$\theta_{JA(MAX)} = \frac{T_J - T_A}{P_D} = \frac{135 - 35}{1.32} = 75.6^\circ C/W$$

3) Select a package from the data sheet with lower θ_{JA} than the one calculated in the previous step.

Selecting TO-252 (D-Pak) with at least 0.5" square of 0.062" FR4 board using 1oz. copper has $70^\circ C/W$ which is lower than the calculated number.

To set the output DC voltage, we need to select R1 and R2:

4) Assuming $R1 = 121\Omega$, 1%:

$$R2 = \left(\frac{V_{OUT}}{V_{REF}} - 1 \right) \times R1 = \left(\frac{2.85}{1.25} - 1 \right) \times 121 = 154.8\Omega$$

Select $R2 = 154\Omega$, 1%

5) Calculate the power dissipation for the schottky diode (D1):

$$\begin{aligned} P_D &= V_F \times I_{OUT} \\ P_D &= 0.5 \times 0.8 = 0.4W \end{aligned}$$

and select a suitable component.

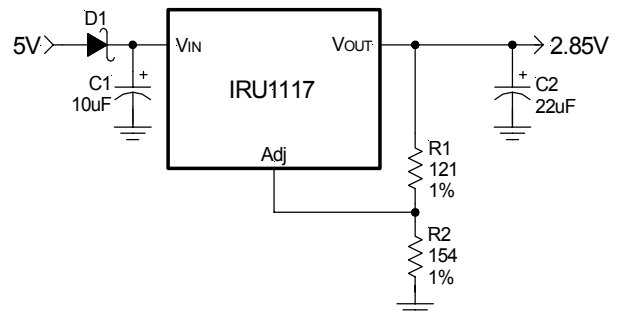
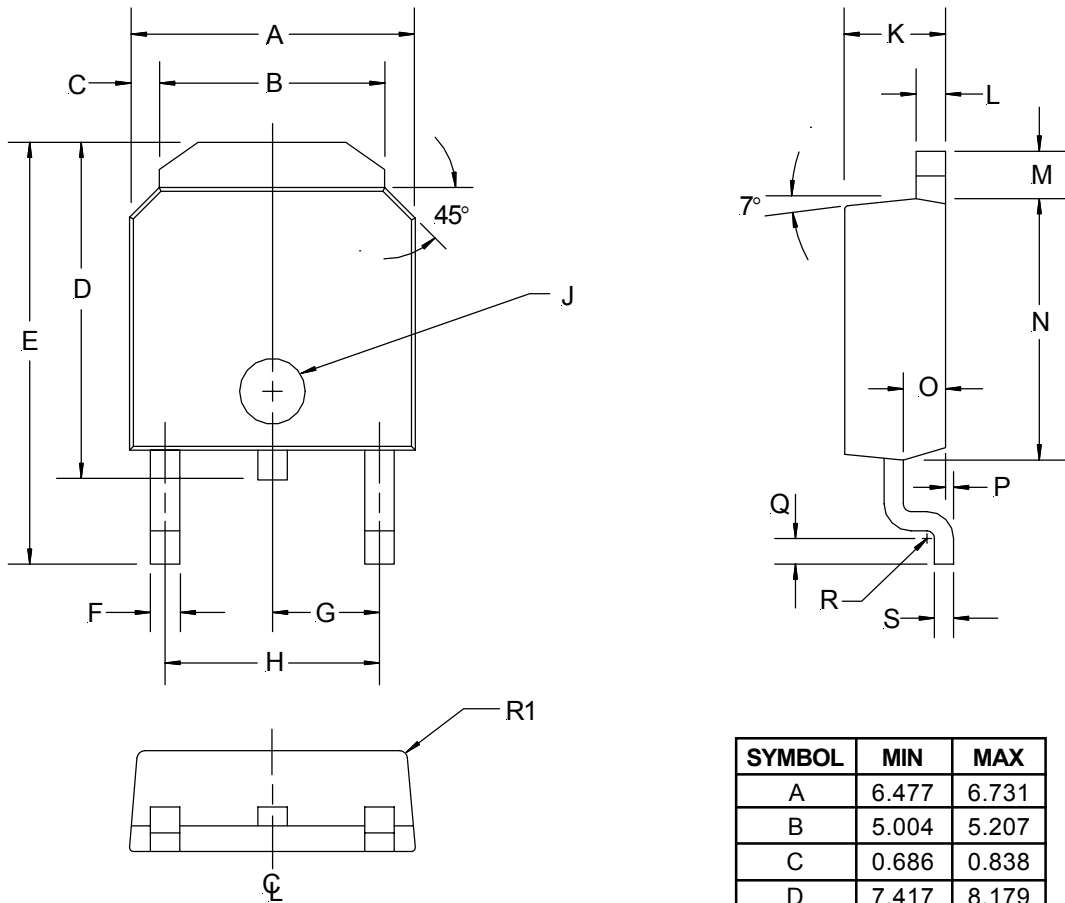

Figure 5 - Final Schematic for half of the GTL+ termination regulator.

Layout Consideration

The output capacitors must be located as close to the V_{OUT} terminal of the device as possible. It is recommended to use a section of a layer of the PC board as a plane to connect the V_{OUT} pin to the output capacitors to prevent any high frequency oscillation that may result due to excessive trace inductance.

**(D) TO-252 Package
 2-Pin**



SYMBOL	MIN	MAX
A	6.477	6.731
B	5.004	5.207
C	0.686	0.838
D	7.417	8.179
E	9.703	10.084
F	0.635	0.889
G	2.286 BSC	
H	4.521	4.623
J	Ø1.52	Ø1.62
K	2.184	2.388
L	0.762	0.864
M	1.016	1.118
N	5.969	6.223
O	1.016	1.118
P	0	0.102
Q	0.534	0.686
R	R0.31 TYP	
R1	R0.51 TYP	
S	0.428	0.588

NOTE: ALL MEASUREMENTS
 ARE IN MILLIMETERS.

**(P) Ultra Thin-Pak™
 2-Pin**

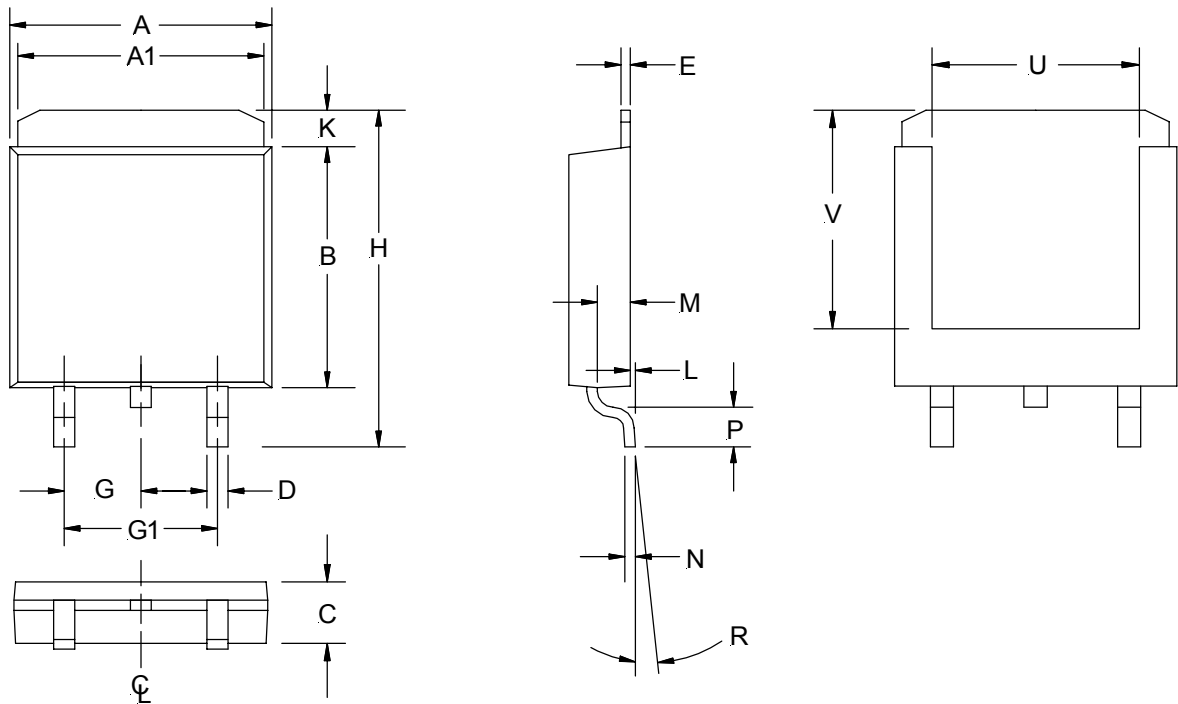

SYMBOL	MIN	MAX
A	5.91	6.17
A1	5.54	5.79
B	6.02	6.27
C	1.70	2.03
D	0.63	0.79
E	0.17	0.33
G	2.16	2.41
G1	4.45	4.70
H	9.42	9.68
K	0.76	1.27
L	0.02	0.13
M	0.89	1.14
N	0.25	0.25
P	0.94	1.19
R	2°	6°
U	2.92	3.30
V	5.08 NOM	

NOTE: ALL MEASUREMENTS
 ARE IN MILLIMETERS.

(S) SOIC Package
8-Pin Surface Mount, Narrow Body

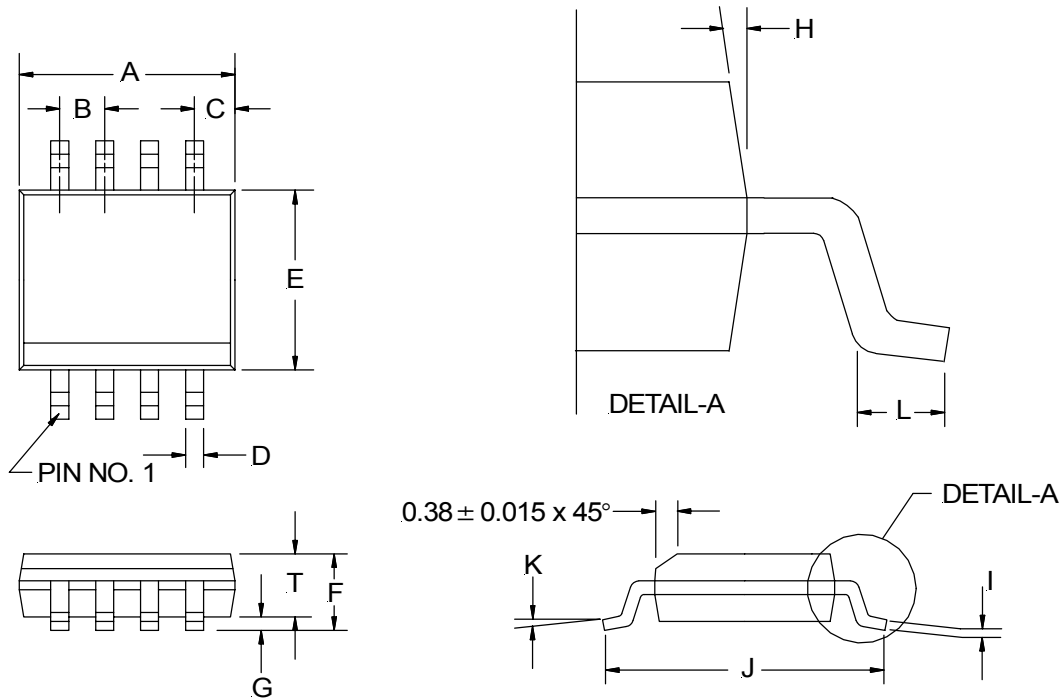

8-PIN		
SYMBOL	MIN	MAX
A	4.80	4.98
B	1.27 BSC	
C	0.53 REF	
D	0.36	0.46
E	3.81	3.99
F	1.52	1.72
G	0.10	0.25
H	7° BSC	
I	0.19	0.25
J	5.80	6.20
K	0°	8°
L	0.41	1.27
T	1.37	1.57

NOTE: ALL MEASUREMENTS
 ARE IN MILLIMETERS.

**(Y) SOT-223 Package
 3-Pin**

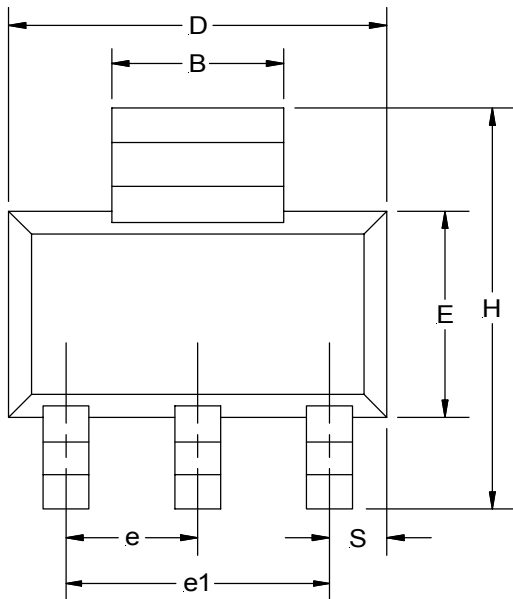

SYMBOL	MIN	MAX
A	1.498	1.702
A1	0.02	0.11
B	2.895	3.15
B1	0.637	0.85
C	0.239	0.381
D	6.299	6.706
E	3.30	3.708
e	2.209	2.953
e1	4.496	4.699
H	6.70	7.30
Q	0°	10°
Q1	7°	16°
Q2	7°	16°
S	0.838	1.05
T	1.092	1.30

NOTE: ALL MEASUREMENTS
 ARE IN MILLIMETERS.

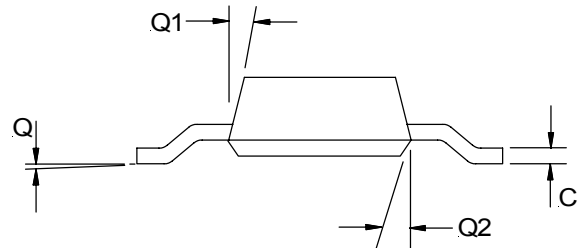
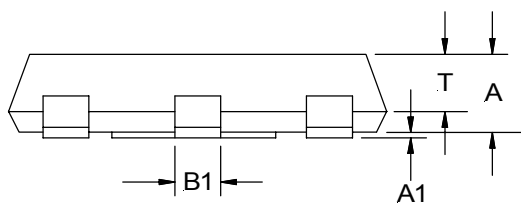

PACKAGE SHIPMENT METHOD

PKG DESIG	PACKAGE DESCRIPTION	PIN COUNT	PARTS PER TUBE	PARTS PER REEL	T & R Orientation
D	TO-252, (D-Pak)	2	75	2500	Fig A
P	Ultra Thin-Pak™	2	75	2500	Fig B
S	SOIC, Narrow Body	8	95	2500	Fig C
Y	SOT-223	3	80	2500	Fig D

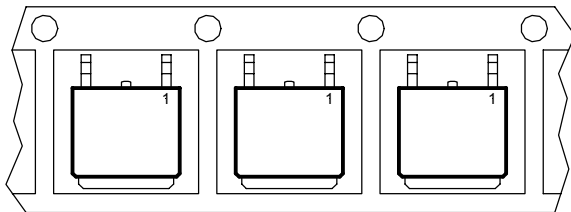

Feed Direction
Figure A

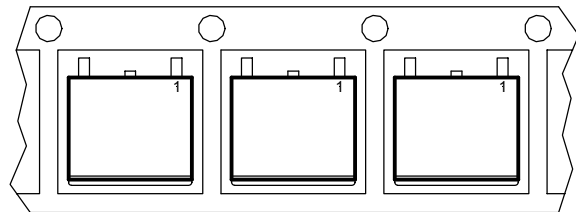

Feed Direction
Figure B

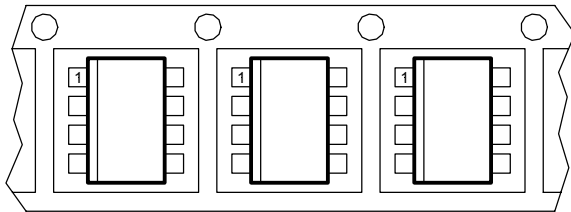

Feed Direction
Figure C

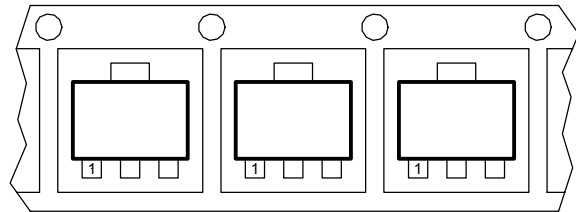

Feed Direction
Figure D