



Chipsmall Limited consists of a professional team with an average of over 10 year of expertise in the distribution of electronic components. Based in Hongkong, we have already established firm and mutual-benefit business relationships with customers from,Europe,America and south Asia,supplying obsolete and hard-to-find components to meet their specific needs.

With the principle of “Quality Parts,Customers Priority,Honest Operation,and Considerate Service”,our business mainly focus on the distribution of electronic components. Line cards we deal with include Microchip,ALPS,ROHM,Xilinx,Pulse,ON,Everlight and Freescale. Main products comprise IC,Modules,Potentiometer,IC Socket,Relay,Connector.Our parts cover such applications as commercial,industrial, and automotives areas.

We are looking forward to setting up business relationship with you and hope to provide you with the best service and solution. Let us make a better world for our industry!



Contact us

Tel: +86-755-8981 8866 Fax: +86-755-8427 6832

Email & Skype: info@chipsmall.com Web: www.chipsmall.com

Address: A1208, Overseas Decoration Building, #122 Zhenhua RD., Futian, Shenzhen, China



**DUAL 6A AND 1A LOW DROPOUT
 POSITIVE FIXED 1.5V AND 2.5V REGULATOR**

FEATURES

- Guaranteed to Provide 1.5V and 2.5V Supplies with 3.1V Input
- Fast Transient Response
- 1% Voltage Reference Initial Accuracy
- Built-In Thermal Shutdown

APPLICATIONS

- Pentium II™ Processor Applications

DESCRIPTION

The IRU1261, using a proprietary process, combines a dual low dropout regulator with fixed outputs of 1.5V and 2.5V in a single package with the 1.5V output having a minimum of 6A and the 2.5V having a 1A output current capability. This product is specifically designed to provide well regulated supplies from 3.3V to generate 1.5V for GTL+ termination resistor supply and 2.5V clock supply for the new generation of the Pentium II™ processor applications.

TYPICAL APPLICATION

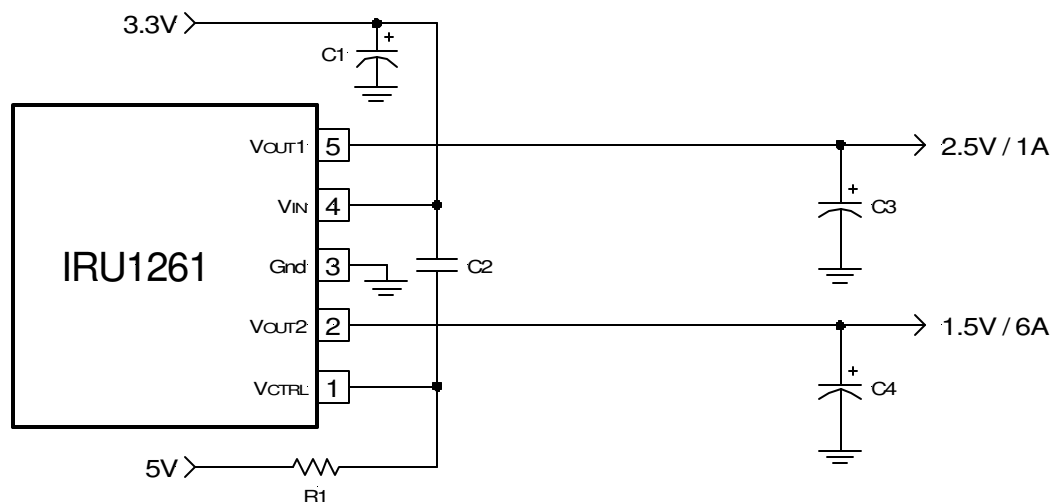

Figure 1 - Typical application of IRU1261 in a Pentium II™ processor application.

Note: Pentium II™ is trademark of Intel Corp.

PACKAGE ORDER INFORMATION

| T _J (°C) | 5-PIN PLASTIC TO-263 (M) | 5-PIN PLASTIC Ultra Thin-Pak™ (P) |
|---------------------|-----------------------------|--------------------------------------|
| 0 To 150 | IRU1261CM | IRU1261CP |

ABSOLUTE MAXIMUM RATINGS

| | |
|--|--------------------|
| Input Voltage (V _{IN}) | 7V |
| Power Dissipation | Internally Limited |
| Storage Temperature Range | -65°C To 150°C |
| Operating Junction Temperature Range | 0°C To 150°C |

PACKAGE INFORMATION

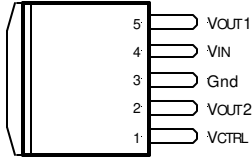
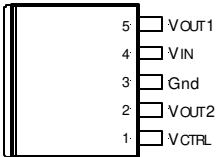
| 5-PIN PLASTIC TO-263 (M) | 5-PIN ULTRA THIN-PAK™ (P) |
|---|---|
|  <p>θ_{JA}=30°C/W for 1"sq pad</p> |  <p>θ_{JA}=30°C/W for 1"sq pad</p> |

ELECTRICAL SPECIFICATIONS

Unless otherwise specified, these specifications apply over C_{IN}=1μF, C_{OUT}=100μF and T_J=0 to 150°C. Typical values refer to T_J=25°C. I_{FL}=6A for output #2 and 1A for output #1. V_{CTRL}=5V, V_{IN}=3.3V.

| PARAMETER | SYM | TEST CONDITION | MIN | TYP | MAX | UNITS |
|---------------------------------|-----------------|--|----------------|-------|----------------|-----------------|
| V _{CTRL} Input Voltage | | | 3.0 | | | V |
| Output Voltage #2 | V _{O2} | I _o =10mA, T _J =25°C I _o =10mA | 1.485 1.470 | 1.500 | 1.515 1.530 | V |
| Output Voltage #1 | V _{O1} | I _o =10mA, T _J =25°C I _o =10mA | 2.462 2.425 | 2.500 | 2.537 2.575 | V |
| Line Regulation | | I _o =10mA, 3.1V<V _{IN} <3.6V | | 0.2 | | % |
| Load Regulation (Note 1) | | 10mA<I _o <I _{FL} | | 0.4 | | % |
| Dropout Voltage (Output #2) | | Note 2, I _o =6A, V _{CTRL} =4.75V | | | 1.3 | V |
| Dropout Voltage (Output #1) | | Note 2, I _o =1A, V _{CTRL} =4.75V | | 0.4 | 0.6 | V |
| Current Limit (Output #2) | | ΔV _o =100mV | 6.1 | | | A |
| Current Limit (Output #1) | | ΔV _o =100mV | 1.1 | | | A |
| Minimum Load Current | | Note 3 | | 5 | 10 | mA |
| Thermal Regulation | | 30ms Pulse, I _o =I _{FL} | | 0.01 | 0.02 | %/W |
| Ripple Rejection | | f=120Hz, C _o =25μF Tantalum, I _o =0.5 × I _{FL} | | 70 | | dB |
| Temperature Stability | | I _o =10mA | | 0.5 | | % |
| Long Term Stability | | T _J =125°C, 1000Hrs | | 0.3 | | % |
| RMS Output Noise | | 10Hz<f<10KHz | | 0.003 | | %V _o |

Note 1: Low duty cycle pulse testing with Kelvin connections is required in order to maintain accurate data.

Note 2: Dropout voltage is defined as the minimum differential voltage between V_{IN} and V_{OUT} required to maintain regulation at V_{OUT}. It is measured when the output voltage drops 1% below its nominal value.

Note 3: Minimum load current is defined as the minimum current required at the output in order for the output voltage to maintain regulation. Typically the resistor dividers are selected such that it automatically maintains this current.

PIN DESCRIPTIONS

| PIN # | PIN SYMBOL | PIN DESCRIPTION |
|-------|-------------------|--|
| 1 | V _{CTRL} | The control input pin of the regulator. This pin is connected, via a 10Ω resistor, to the 5V supply to provide the base current for the pass transistor of both regulators. This allows the regulator to have very low dropout voltage which allows one to generate a well regulated 2.5V supply from the 3.3V input. A high frequency, 1μF capacitor is connected between this pin and V _{IN} pin to insure stability. |
| 2 | V _{OUT2} | The output #2 (high current) of the regulator. A minimum of 100μF capacitor must be connected from this pin to ground to insure stability. |
| 3 | Gnd | This pin is connected to ground. It is also the Tab of the package. |
| 4 | V _{IN} | The power input pin of the regulator. Typically a large storage capacitor is connected from this pin to ground to insure that the input voltage does not sag below the minimum drop out voltage during the load transient response. This pin must always be higher than both V _{OUT} pins by the amount of the dropout voltage (see data sheet) in order for the device to regulate properly. |
| 5 | V _{OUT1} | The output #1 (low current) of the regulator. A minimum of 100μF capacitor must be connected from this pin to ground to insure stability. |

BLOCK DIAGRAM

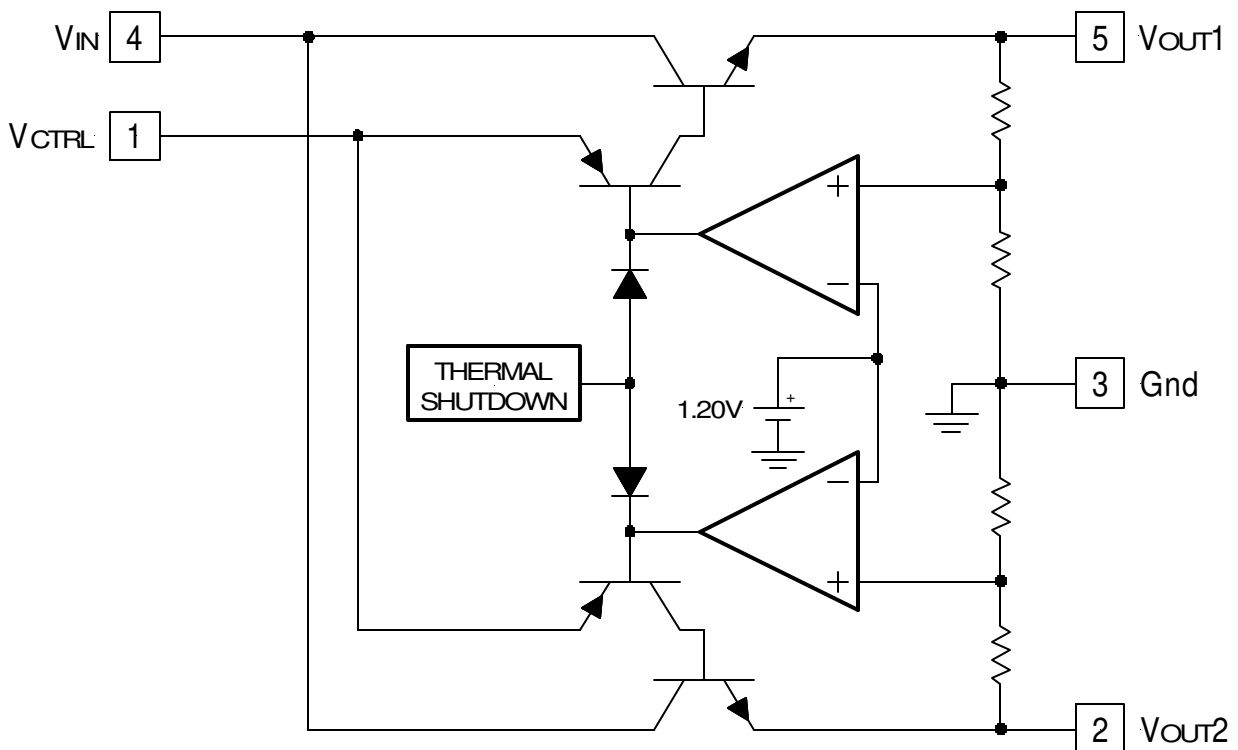

Figure 2 - Simplified block diagram of the IRU1261.

APPLICATION INFORMATION

Introduction

The IRU1261 is a dual fixed output Low Dropout (LDO) regulator available in a TO-263 package. This voltage regulator is designed specifically for Pentium II processor applications requiring 2.5V and 1.5V supplies, eliminating the need for a second regulator resulting in lower overall system cost. The IRU1261 is designed to take advantage of 5V supply to provide the drive for the pass transistor, allowing 2.5V supply to be generated from 3.3V input. This feature improves the power dissipation of the 2.5V regulator substantially allowing a smaller heat sink to be used for the application. Compared to the IRU1260 dual adjustable regulator, the IRU1261 includes the resistor dividers that are otherwise needed with the IRU1260, eliminating four external components and their tolerances, resulting in a more accurate initial accuracy for each output voltage. Other features of the device include: fast response to sudden load current changes, such as GTL+ termination application and thermal shutdown protection to protect the device if an overload condition occurs.

Stability

The IRU1261 requires the use of an output capacitor as part of the frequency compensation in order to make the regulator stable. Typical designs for the microprocessor applications use standard electrolytic capacitors with typical ESR in the range of 50 to 100mΩ and the output capacitance of 500 to 1000μF. Fortunately as the capacitance increases, the ESR decreases resulting in a fixed RC time constant. The IRU1261 takes advantage of this phenomena in making the overall regulator loop stable. For most applications a minimum of 100μF aluminum electrolytic capacitor with the maximum ESR of 0.3Ω such as Sanyo, MVGX series, Panasonic FA series as well as the Nichicon PL series insures both stability and good transient response. The IRU1261 also requires a 1μF ceramic capacitor connected from V_{IN} to V_{CTRL} and a 10Ω, 0.1W resistor in series with V_{CTRL} pin in order to further insure stability.

Thermal Design

The IRU1261 incorporates an internal thermal shutdown that protects the device when the junction temperature exceeds the maximum allowable junction temperature. Although this device can operate with junction temperatures in the range of 150°C, it is recommended that the selected heat sink be chosen such that during maxi-

um continuous load operation the junction temperature is kept below this number. The example given shows the steps in selecting the proper regulator heat sink for driving the Pentium II processor GTL+ termination resistors and the Clock IC using IRU1261 in TO-263 package.

Example:

Assuming the following specifications:

$$\begin{aligned} V_{IN} &= 3.3V \\ V_{OUT1} &= 2.5V \\ V_{OUT2} &= 1.5V \\ I_{OUT1(MAX)} &= 0.2A \\ I_{OUT2(MAX)} &= 1.5A \\ T_A &= 35^\circ C \end{aligned}$$

The steps for selecting a proper heat sink to keep the junction temperature below 135°C is given as:

- 1) Calculate the maximum power dissipation using:

$$\begin{aligned} P_D &= I_{OUT1} \times (V_{IN} - V_{OUT1}) + I_{OUT2} \times (V_{IN} - V_{OUT2}) \\ P_D &= 0.2 \times (3.3 - 2.5) + 1.5 \times (3.3 - 1.5) = 2.86W \end{aligned}$$

- 2) Assuming a TO-263 surface mount package, the junction to ambient thermal resistance of the package is:

$$\theta_{JA} = 30^\circ C/W \text{ for } 1" \text{ square pad area}$$

- 3) The maximum junction temperature of the device is calculated using the equation below:

$$\begin{aligned} T_J &= T_A + P_D \times \theta_{JA} \\ T_J &= 35 + 2.86 \times 30 = 121^\circ C \end{aligned}$$

Since this is lower than our selected 135°C maximum junction temperature (150°C is the thermal shutdown of the device), TO-263 package is a suitable package for our application.

Layout Consideration

The IRU1261 like all other high speed linear regulators need to be properly laid out to insure stable operation. The most important component is the output capacitor, which needs to be placed close to the output pin and connected to this pin using a plane connection with a low inductance path.

TYPICAL APPLICATION

PENTIUM II™ APPLICATION

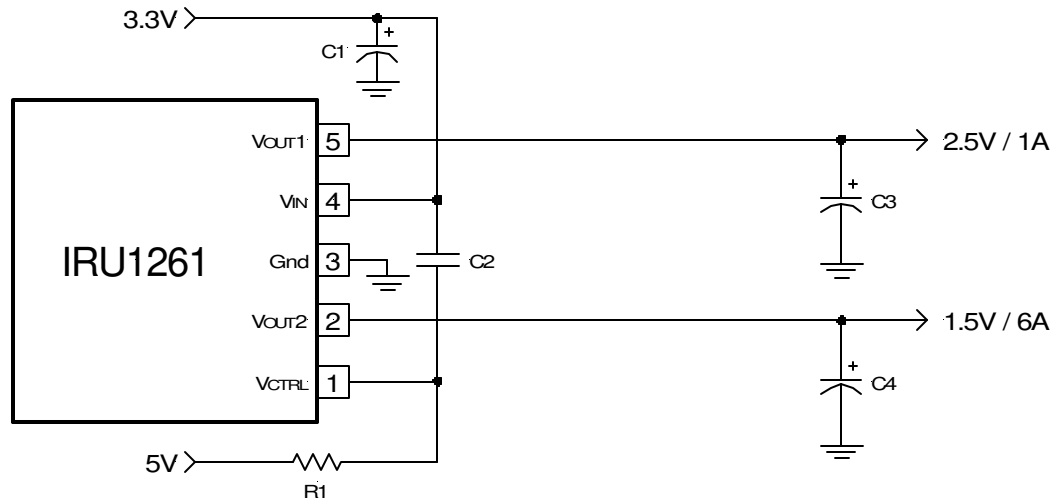
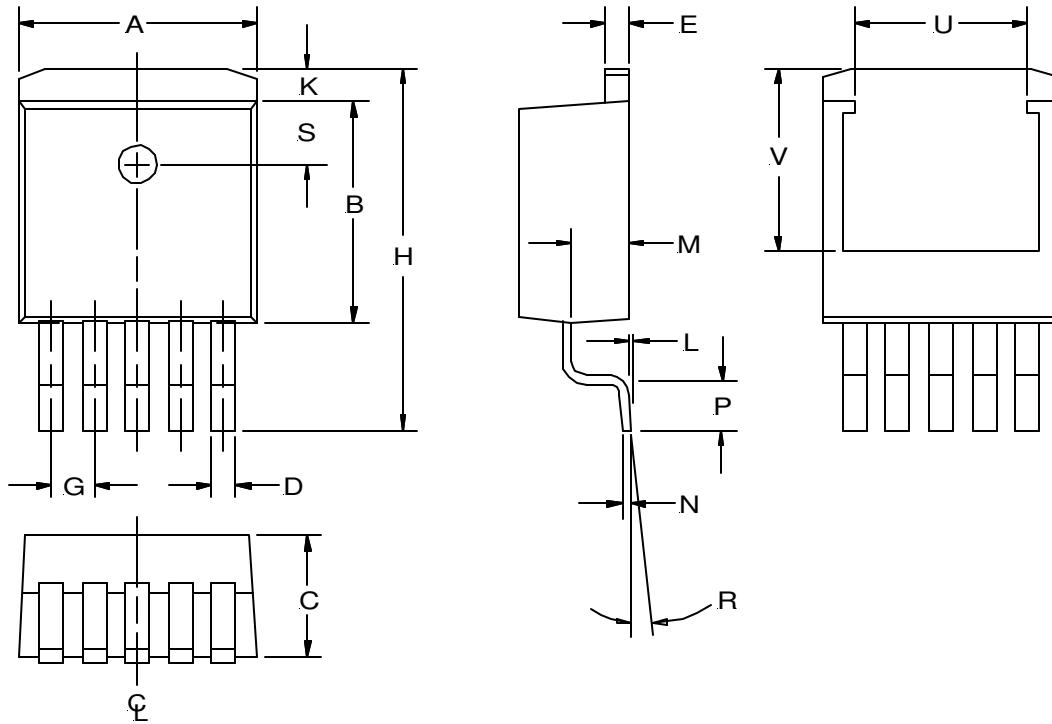

Figure 3 - Typical application of IRU1261 in the Pentium II™ design with the 1.5V output providing for GTL+ termination while 2.5V supplies the clock chip.

Note: Pentium II™ is trademark of Intel Corp.

| Ref Desig | Description | Qty | Part # | Manuf |
|-----------|--------------------|-----|---|-----------|
| U1 | Dual LDO Regulator | 1 | IRU1261CM | IR |
| C1, C4 | Capacitor | 2 | Elect, 680 μ F, EEUFA1A681L | Panasonic |
| C3 | Capacitor | 1 | Elect, 220 μ F, 6.3V, ECAOJFQ221 | Panasonic |
| C2 | Capacitor | 1 | Ceramic, 1 μ F, 16V, Z5U | |
| R1 | Resistor | 1 | 3 Ω , 0.1W, 0805 SMT | Panasonic |
| HS1 | Heat Sink | | 1) Use 1" Square Copper Pad area if $I_{OUT2} < 1.7A$ and $I_{OUT1} < 0.2A$. 2) For $I_{OUT2} < 3A$ and $I_{OUT1} < 0.5A$, use IRU1261CT and Thermalloy 6030B 3) For $I_{OUT2} < 5.4A$ and $I_{OUT1} < 0.5A$, use IRU1261CT and Thermalloy 7021B | |

(M) TO-263 Package
 5-Pin



| SYMBOL | MIN | MAX |
|--------|----------|--------|
| A | 10.05 | 10.668 |
| B | 8.28 | 9.169 |
| C | 4.31 | 4.597 |
| D | 0.66 | 0.91 |
| E | 1.14 | 1.40 |
| G | 1.575 | 1.829 |
| H | 14.605 | 15.875 |
| K | 1.143 | 1.68 |
| L | 0.00 | 0.305 |
| M | 2.49 | 2.74 |
| N | 0.33 | 0.58 |
| P | 2.286 | 2.794 |
| R | 0° | 8° |
| S | 1.143 | 2.67 |
| U | 6.50 REF | |
| V | 7.75 REF | |

NOTE: ALL MEASUREMENTS
 ARE IN MILLIMETERS.

**(P) Ultra Thin-Pak™
 5-Pin**

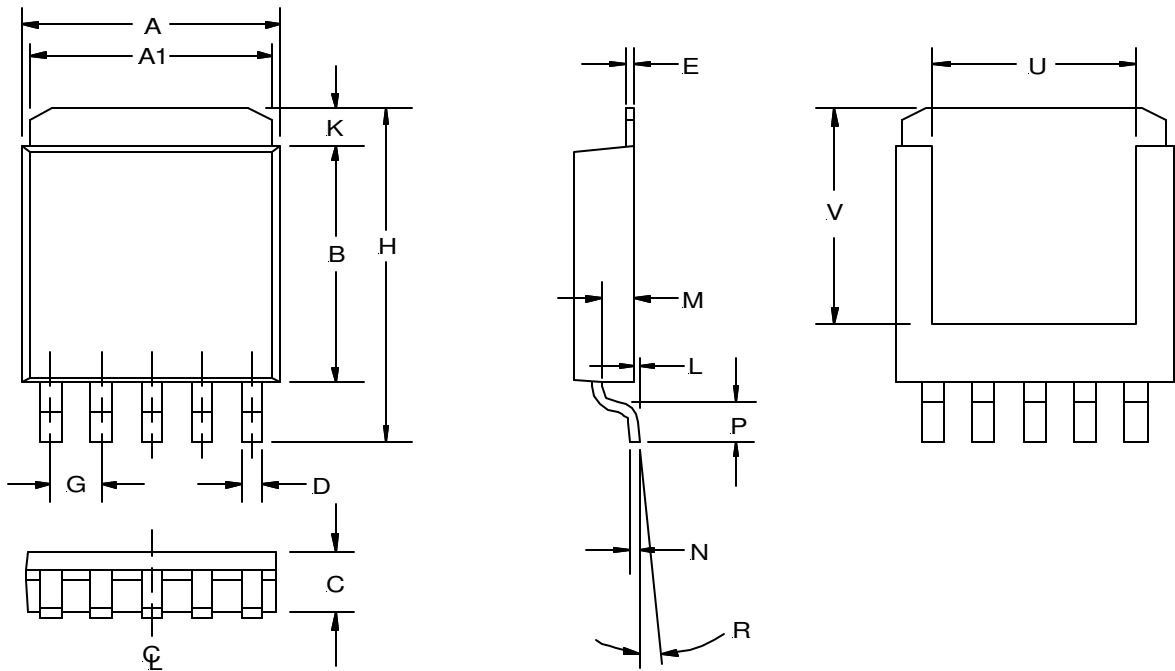

| SYMBOL | MIN | MAX |
|--------|----------|-------|
| A | 9.27 | 9.52 |
| A1 | 8.89 | 9.14 |
| B | 7.87 | 8.13 |
| C | 1.78 | 2.03 |
| D | 0.63 | 0.79 |
| E | 0.25 NOM | |
| G | 1.72 | |
| H | 10.41 | 10.67 |
| K | 0.76 | 1.27 |
| L | 0.03 | 0.13 |
| M | 0.89 | 1.14 |
| N | 0.25 | |
| P | 0.79 | 1.04 |
| R | 3° | 6° |
| U | 5.59 NOM | |
| V | 7.49 NOM | |

NOTE: ALL MEASUREMENTS
 ARE IN MILLIMETERS.

PACKAGE SHIPMENT METHOD

| PKG DESIG | PACKAGE DESCRIPTION | PIN COUNT | PARTS PER TUBE | PARTS PER REEL | T & R Orientation |
|-----------|---------------------|-----------|----------------|----------------|-------------------|
| M | TO-263 | 5 | 50 | 750 | Fig A |
| P | Ultra Thin-Pak™ | 5 | 75 | 2500 | Fig B |

