



Chipsmall Limited consists of a professional team with an average of over 10 year of expertise in the distribution of electronic components. Based in Hongkong, we have already established firm and mutual-benefit business relationships with customers from,Europe,America and south Asia,supplying obsolete and hard-to-find components to meet their specific needs.

With the principle of "Quality Parts,Customers Priority,Honest Operation,and Considerate Service",our business mainly focus on the distribution of electronic components. Line cards we deal with include Microchip,ALPS,ROHM,Xilinx,Pulse,ON,Everlight and Freescale. Main products comprise IC,Modules,Potentiometer,IC Socket,Relay,Connector.Our parts cover such applications as commercial,industrial, and automotives areas.

We are looking forward to setting up business relationship with you and hope to provide you with the best service and solution. Let us make a better world for our industry!



Contact us

Tel: +86-755-8981 8866 Fax: +86-755-8427 6832

Email & Skype: info@chipsmall.com Web: www.chipsmall.com

Address: A1208, Overseas Decoration Building, #122 Zhenhua RD., Futian, Shenzhen, China



**DUAL 6A AND 1A LOW DROPOUT
 POSITIVE FIXED 1.5V AND 2.5V REGULATOR**

FEATURES

- Guaranteed to Provide 1.5V and 2.5V Supplies with 3.1V Input
- Fast Transient Response
- 1% Voltage Reference Initial Accuracy
- Built-In Thermal Shutdown

APPLICATIONS

- Pentium II Processor Applications

DESCRIPTION

The IRU1261, using a proprietary process, combines a dual low dropout regulator with fixed outputs of 1.5V and 2.5V in a single package with the 1.5V output having a minimum of 6A and the 2.5V having a 1A output current capability. This product is specifically designed to provide well regulated supplies from 3.3V to generate 1.5V for GTL+ termination resistor supply and 2.5V clock supply for the new generation of the Pentium II processor applications.

TYPICAL APPLICATION

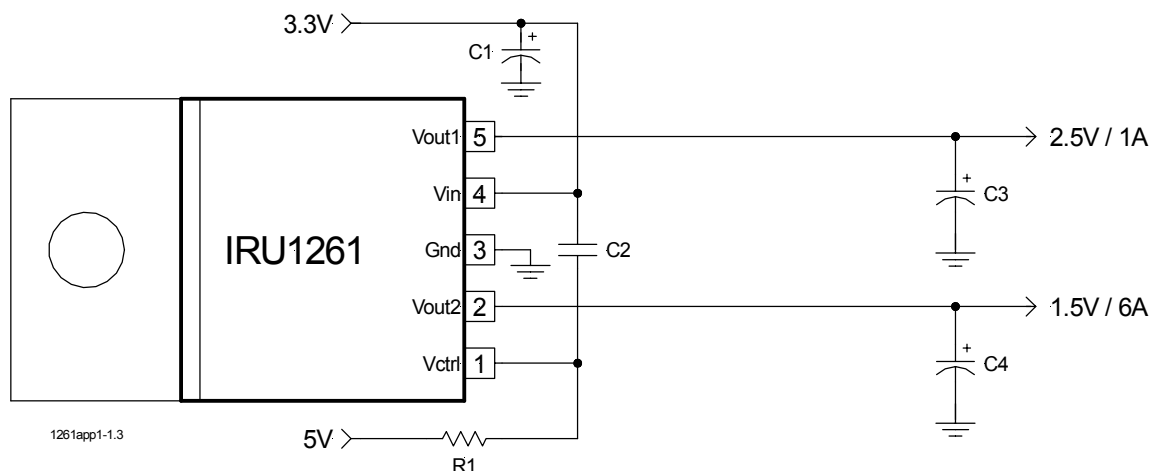

Figure 1 - Typical application of IRU1261 in a Pentium II processor application

PACKAGE ORDER INFORMATION

Tj (°C)	5-PIN PLASTIC TO-220 (T)	5-PIN PLASTIC TO-263 (M)	5-PIN PLASTIC Ultra Thin-Pak (P)
0 To 150	IRU1261CT	IRU1261CM	IRU1261CP

IRU1261

ABSOLUTE MAXIMUM RATINGS

Input Voltage (Vin)	7V
Power Dissipation	Internally Limited
Storage Temperature Range	-65°C To 150°C
Operating Junction Temperature Range	0°C To 150°C

PACKAGE INFORMATION

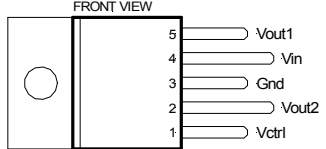
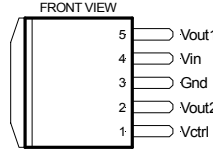
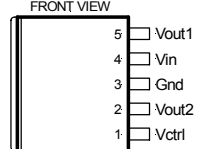
7-PIN PLASTIC TO-220 (T)	7-PIN PLASTIC TO-263 (M)	7-PIN ULTRA THIN-PAK (P)
 <p>$\theta_{JT}=2.7^{\circ}\text{C/W}$, $\theta_{JA}=60^{\circ}\text{C/W}$</p>	 <p>$\theta_{JA}=30^{\circ}\text{C/W}$ for 1"sq pad</p>	 <p>$\theta_{JA}=30^{\circ}\text{C/W}$ for 1"sq pad</p>

ELECTRICAL SPECIFICATIONS

Unless otherwise specified, these specifications apply over $C_{in}=1\mu\text{F}$, $C_{out}=100\mu\text{F}$ and $T_j=0$ to 150°C . Typical values refer to $T_j=25^{\circ}\text{C}$. $I_{FL}=6\text{A}$ for output #2 and 1A for output #1. $V_{ctrl}=5\text{V}$, $V_{in}=3.3\text{V}$.

PARAMETER	SYM	TEST CONDITION	MIN	TYP	MAX	UNITS
Vctrl Input Voltage			3.0			V
Output Voltage #2	Vo2	$I_o=10\text{mA}$, $T_j=25^{\circ}\text{C}$ $I_o=10\text{mA}$	1.485 1.470	1.500 1.500	1.515 1.530	V
Output Voltage #1	Vo1	$I_o=10\text{mA}$, $T_j=25^{\circ}\text{C}$ $I_o=10\text{mA}$	2.462 2.425	2.500 2.500	2.537 2.575	V
Line Regulation		$I_o=10\text{mA}$, $3.1\text{V}<V_{in}<3.6\text{V}$		0.2		%
Load Regulation (Note 1)		$10\text{mA}<I_o<I_{FL}$		0.4		%
Dropout Voltage (Output #2)		Note 2, $I_o=6\text{A}$, $V_{ctrl}=4.75\text{V}$			1.3	V
Dropout Voltage (Output #1)		Note 2, $I_o=1\text{A}$, $V_{ctrl}=4.75\text{V}$		0.4	0.6	V
Current Limit (Output #2)		$\Delta V_o=100\text{mV}$	6.1			A
Current Limit (Output #1)		$\Delta V_o=100\text{mV}$	1.1			A
Minimum Load Current		Note 3		5	10	mA
Thermal Regulation		30ms Pulse, $I_o=I_{FL}$		0.01	0.02	%/W
Ripple Rejection		$f=120\text{Hz}$, $C_o=25\mu\text{F}$ Tantalum, $I_o=0.5 \times I_{FL}$		70		dB
Temperature Stability		$I_o=10\text{mA}$		0.5		%
Long Term Stability		$T_j=125^{\circ}\text{C}$, 1000Hrs		0.3		%
RMS Output Noise		$10\text{Hz}<f<10\text{KHz}$		0.003		%Vo

Note 1: Low duty cycle pulse testing with Kelvin connections is required in order to maintain accurate data.

Note 2: Dropout voltage is defined as the minimum differential voltage between V_{in} and V_{out} required to maintain regulation at V_{out} . It is measured when the output voltage drops 1% below its nominal value.

Note 3: Minimum load current is defined as the minimum current required at the output in order for the output voltage to maintain regulation. Typically the resistor dividers are selected such that it automatically maintains this current.

PIN DESCRIPTIONS

PIN #	PIN SYMBOL	PIN DESCRIPTION
1	Vctrl	The control input pin of the regulator. This pin is connected, via a 10Ω resistor, to the 5V supply to provide the base current for the pass transistor of both regulators. This allows the regulator to have very low dropout voltage which allows one to generate a well regulated 2.5V supply from the 3.3V input. A high frequency, 1μF capacitor is connected between this pin and Vin pin to insure stability.
2	Vout2	The output #2 (high current) of the regulator. A minimum of 100μF capacitor must be connected from this pin to ground to insure stability.
3	Gnd	This pin is connected to ground. It is also the Tab of the package.
4	Vin	The power input pin of the regulator. Typically a large storage capacitor is connected from this pin to ground to insure that the input voltage does not sag below the minimum drop out voltage during the load transient response. This pin must always be higher than both Vout pins by the amount of the dropout voltage (see data sheet) in order for the device to regulate properly.
5	Vout1	The output #1 (low current) of the regulator. A minimum of 100μF capacitor must be connected from this pin to ground to insure stability.

BLOCK DIAGRAM

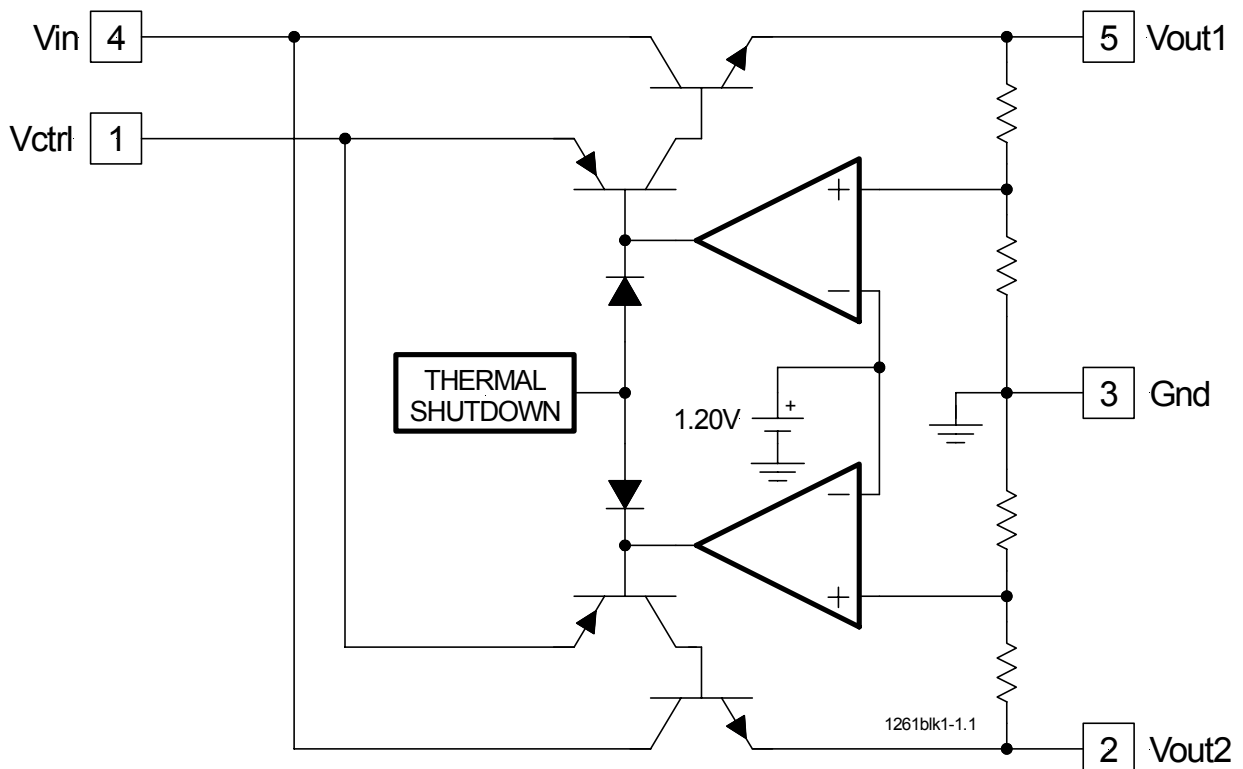

Figure 2 - Simplified block diagram of the IRU1261

APPLICATION INFORMATION

Introduction

The IRU1261 is a dual fixed output Low Dropout (LDO) regulator available in a 5-pin TO-220 or TO-263 packages. This voltage regulator is designed specifically for PentiumII processor applications requiring 2.5V and 1.5V supplies, eliminating the need for a second regulator resulting in lower overall system cost. The IRU1261 is designed to take advantage of 5V supply to provide the drive for the pass transistor, allowing 2.5V supply to be generated from 3.3V input. This feature improves the power dissipation of the 2.5V regulator substantially allowing a smaller heat sink to be used for the application. Compared to the IRU1260 dual adjustable regulator, the IRU1261 includes the resistor dividers that are otherwise needed with the IRU1260, eliminating four external components and their tolerances, resulting in a more accurate initial accuracy for each output voltage. Other features of the device include: fast response to sudden load current changes, such as GTL+ termination application and thermal shutdown protection to protect the device if an overload condition occurs.

Stability

The IRU1261 requires the use of an output capacitor as part of the frequency compensation in order to make the regulator stable. Typical designs for the microprocessor applications use standard electrolytic capacitors with typical ESR in the range of 50 to 100mΩ and the output capacitance of 500 to 1000μF. Fortunately as the capacitance increases, the ESR decreases resulting in a fixed RC time constant. The IRU1261 takes advantage of this phenomena in making the overall regulator loop stable. For most applications a minimum of 100μF aluminum electrolytic capacitor with the maximum ESR of 0.3Ω such as Sanyo, MVGX series, Panasonic FA series as well as the Nichicon PL series insures both stability and good transient response. The IRU1261 also requires a 1μF ceramic capacitor connected from Vin to Vctrl and a 10Ω, 0.1W resistor in series with Vctrl pin in order to further insure stability.

Thermal Design

The IRU1261 incorporates an internal thermal shutdown that protects the device when the junction temperature exceeds the maximum allowable junction temperature. Although this device can operate with junction temperatures in the range of 150°C, it is recommended that the selected heat sink be chosen such that during maxi-

mum continuous load operation the junction temperature is kept below this number. Two examples are given which shows the steps in selecting the proper regulator heat sink for driving the Pentium II processor GTL+ termination resistors and the Clock IC using IRU1261 in TO-220 and TO-263 packages.

Example # 1:

Assuming the following specifications:

$$\begin{aligned}V_{IN} &= 3.3V \\V_{OUT2} &= 1.5V \\V_{OUT1} &= 2.5V \\I_{OUT2(MAX)} &= 5.4A \\I_{OUT1(MAX)} &= 0.4A \\T_A &= 35^\circ C\end{aligned}$$

The steps for selecting a proper heat sink to keep the junction temperature below 135°C is given as:

- 1) Calculate the maximum power dissipation using:

$$\begin{aligned}P_D &= I_{OUT1} \times (V_{IN} - V_{OUT1}) + I_{OUT2} \times (V_{IN} - V_{OUT2}) \\P_D &= 0.4 \times (3.3 - 2.5) + 5.4 \times (3.3 - 1.5) = 10W\end{aligned}$$

- 2) Select a package from the data sheet and record its junction to case (or Tab) thermal resistance.

Selecting TO-220 package gives us:

$$\theta_{JC} = 2.7^\circ C/W$$

- 3) Assuming that the heat sink is black anodized, calculate the maximum heat sink temperature allowed:

Assume, $\theta_{CS} = 0.05^\circ C/W$ (heat-sink-to-case thermal resistance for black anodized)

$$\begin{aligned}T_S &= T_J - P_D \times (\theta_{JC} + \theta_{CS}) \\T_S &= 135 - 10 \times (2.7 + 0.05) = 107.4^\circ C\end{aligned}$$

- 4) With the maximum heat sink temperature calculated in the previous step, the heat-sink-to-air thermal resistance θ_{SA} is calculated as follows:

$$\begin{aligned}\Delta T &= T_S - T_A = 107.4 - 35 = 72.4^\circ C \\ \theta_{SA} &= \frac{\Delta T}{P_D} = \frac{72.4}{10} = 7.24^\circ C/W\end{aligned}$$

5) Next, a heat sink with lower θ_{SA} than the one calculated in Step 4 must be selected. One way to do this is to simply look at the graphs of the “Heat Sink Temp Rise Above the Ambient” vs. the “Power Dissipation” and select a heat sink that results in lower temperature rise than the one calculated in previous step. The following heat sinks from AAVID and Thermalloy meet this criteria.

	Air Flow (LFM)				
	0	100	200	300	400
Thermalloy	7021B	7020B	6021PB	7173D	7141D
AAVID	593101B	551002B	534202B	577102B	576802B

Note: For further information regarding the above companies and their latest product offering and application support contact your local representative or the numbers listed below:

Thermalloy.....PH# (214) 243-4321
 AAVID.....PH# (603) 528-3400

Example # 2 :

Assuming the following specifications:

- $V_{IN} = 3.3V$
- $V_{OUT2} = 1.5V$
- $V_{OUT1} = 2.5V$
- $I_{OUT2(MAX)} = 1.5A$
- $I_{OUT1(MAX)} = 0.2A$
- $T_A = 35^\circ C$

The steps for selecting a proper heat sink to keep the junction temperature below $135^\circ C$ is given as:

1) Calculate the maximum power dissipation using:

$$P_D = I_{OUT1} \times (V_{IN} - V_{OUT1}) + I_{OUT2} \times (V_{IN} - V_{OUT2})$$

$$P_D = 0.2 \times (3.3 - 2.5) + 1.5 \times (3.3 - 1.5) = 2.86W$$

2) Assuming a TO-263 surface mount package, the junction to ambient thermal resistance of the package is:

$$\theta_{JA} = 30^\circ C/W \text{ for } 1" \text{ square pad area}$$

3) The maximum junction temperature of the device is calculated using the equation below:

$$T_J = T_A - P_D \times \theta_{JA}$$

$$T_J = 35 - 2.86 \times 30 = 121^\circ C$$

Since this is lower than our selected $135^\circ C$ maximum junction temperature ($150^\circ C$ is the thermal shut-down of the device), TO-263 package is a suitable package for our application.

Layout Consideration

The IRU1261 like all other high speed linear regulators need to be properly laid out to insure stable operation. The most important component is the output capacitor, which needs to be placed close to the output pin and connected to this pin using a plane connection with a low inductance path.

IRU1261

TYPICAL APPLICATION

PENTIUM II™ APPLICATION

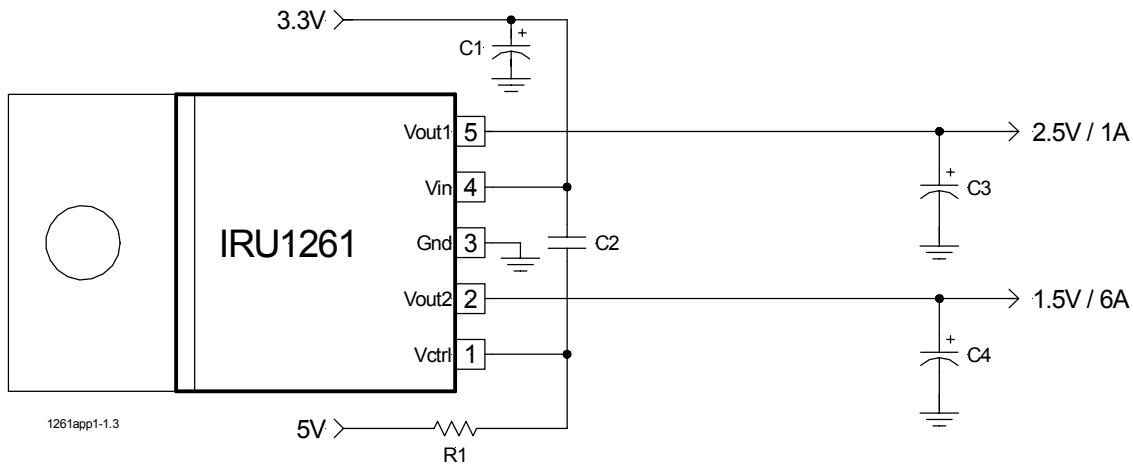

Figure 3 - Typical application of IRU1261 in the Pentium II™ design with the 1.5V output providing for GTL+ termination while 2.5V supplies the clock chip

Note: Pentium II is trademark of Intel Corp.

Ref Desig	Description	Qty	Part #	Manuf
U1	Dual LDO Regulator	1	IRU1261CM	IR
C1, C4	Capacitor	2	Elect, 680 μ F, EEUFA1A681L	Panasonic
C3	Capacitor	1	Elect, 220 μ F, 6.3V, ECAOJFQ221	Panasonic
C2	Capacitor	1	Ceramic, 1 μ F, 16V, Z5U	
R1	Resistor	1	3 Ω , 0.1W, 0805 SMT	Panasonic
HS1	Heat Sink		1) Use 1" Square Copper Pad area if $I_{OUT2} < 1.7A$ and $I_{OUT1} < 0.2A$. 2) For $I_{OUT2} < 3A$ and $I_{OUT1} < 0.5A$, use IRU1261CT and Thermalloy 6030B 3) For $I_{OUT2} < 5.4A$ and $I_{OUT1} < 0.5A$, use IRU1261CT and Thermalloy 7021B	

International
IR Rectifier

IR WORLD HEADQUARTERS : 233 Kansas St., El Segundo, California 90245, USA Tel: (310) 252-7105
 TAC Fax: (310) 252-7903

Visit us at www.irf.com for sales contact information.
 Data and specifications subject to change without notice. 02/01