



Chipsmall Limited consists of a professional team with an average of over 10 year of expertise in the distribution of electronic components. Based in Hongkong, we have already established firm and mutual-benefit business relationships with customers from,Europe,America and south Asia,supplying obsolete and hard-to-find components to meet their specific needs.

With the principle of “Quality Parts,Customers Priority,Honest Operation,and Considerate Service”,our business mainly focus on the distribution of electronic components. Line cards we deal with include Microchip,ALPS,ROHM,Xilinx,Pulse,ON,Everlight and Freescale. Main products comprise IC,Modules,Potentiometer,IC Socket,Relay,Connector.Our parts cover such applications as commercial,industrial, and automotives areas.

We are looking forward to setting up business relationship with you and hope to provide you with the best service and solution. Let us make a better world for our industry!



## Contact us

Tel: +86-755-8981 8866 Fax: +86-755-8427 6832

Email & Skype: info@chipsmall.com Web: www.chipsmall.com

Address: A1208, Overseas Decoration Building, #122 Zhenhua RD., Futian, Shenzhen, China



# IS31BL3231 Flash LED Driver Evaluation Board Guide

## Description

IS31BL3231 flash LED driver demo board is used to demonstrate and evaluate the IS31BL3231. The IS31BL3231 is a current-regulated charge pump and ideal for powering high brightness LEDs for camera flash and torch applications. The charge pump can be set to regulate two current levels for Flash Mode and Torch Mode.

## Features

- Supply voltage range from 2.7V to 5.5V
- Output current up to 750mA
- Adjustable output current in Flash Mode
- Automatic boost mode
- Available in DFN-10 (3mm × 3mm) package

## Quick Start

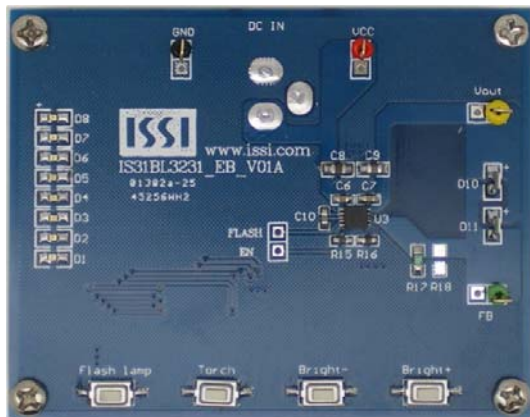

Figure 1: Photo of IS31BL3231 Evaluation Board

## Ordering Information

Part No.	Temperature Range	Package
IS31BL3231-DLS2-EB	-40°C to +85°C (Industrial)	DFN-10 (3mm x 3mm), Lead-free

Table 1: Ordering Information

## Recommended Equipment

- 5.0V, 2A power supply

## Absolute Maximum Ratings

- ≤ 5.5V power supply

**Caution: Do not exceed the conditions listed above; otherwise the board will be damaged.**

## Procedure

The IS31BL3231 demo board is fully assembled and tested. Follow the steps listed below to verify board operation.

**Caution: Do not turn on the power supply until all connections are completed.**

1. Connect the ground terminal of the power supply to the GND pin and the power supply's positive terminal to the VCC pin.
2. Alternatively, a DC source can be connected directly to the (DC IN) connector.
3. Turn on the power supply and pay attention to the supply current. If it is over 2A, please check evaluation board for any faults; if errors are evident please contact ISSI immediately.
4. Switch between Torch Mode and Flash Mode via corresponding push button on board.

**For additional information regarding orders, pricing, and delivery, please contact ISSI at [analog\\_mkt@issi.com](mailto:analog_mkt@issi.com) or (408) 969-6600.**



# IS31BL3231 Flash LED Driver Evaluation Board Guide

---

## Performance Display

---

The IS31BL3231 Flash LED Driver can function in Flash Mode or Torch Mode. Torch is set as the default mode.

- Torch Mode: The White LEDs are working in the Torch Mode when power on. There are 8 blue LEDs showing the intensity level. The intensity of LEDs will be increased at 8 steps by pressing the Bright+ button, and decreased by pressing the Bright- button. Press the Torch button in this mode to operating in the Flash Mode.
- Flash Mode: The Flash Mode is activated when shut down the Torch Mode. The high brightness LEDs will flash once by clicking the Flash button.

## Software Support

---

Please refer to the integrated evaluation board software. It is pre-programmed for easy set-up and demonstration. For more information on IS31BL3231, please refer to the device's datasheet.



# IS31BL3231 Flash LED Driver Evaluation Board Guide

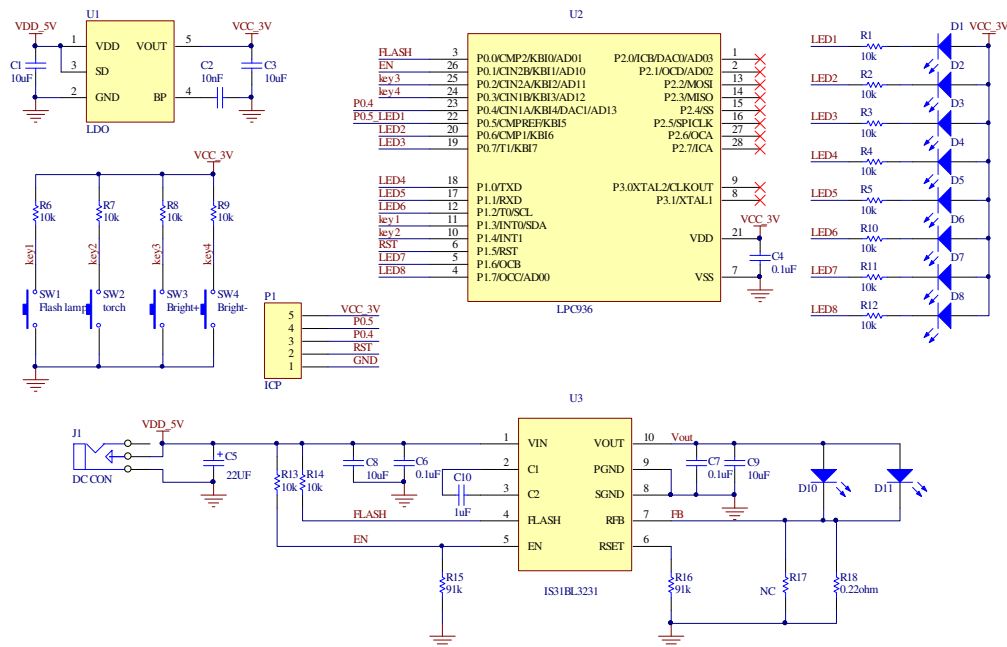

Figure 2: IS31BL3231 Application Circuit Diagram

## Bill of Materials

Name	Symbol	Description	Qty	Supplier	Part No.
LDO	U1	Low Drop-out Regulator	1	PAM	PAM3101DAB300
MCU	U2	System Microcontroller	1	NXP	P89LPC936
LED Driver	U3	LED Backlighting Driver	1	ISSI	IS31BL3231
Diode	D1-8	Diode, LED Blue, SMD	8	Everlight	19-217/BHC-ZL1M2RY/3T
Diode	D10-11	Diode, LED White, SMD	2	Everlight	EHP-C04/UT01-P01/TR
Resistor	R1-R14	RES,10k,1/16W,±5%,SMD	14	-	-
Resistor	R15,R16	RES,91k,1/16W,±5%,SMD	2	-	-
Resistor	R17	Not Connected	1	-	-
Resistor	R18	RES,0.22Ω,1/16W,±5%,SMD	1	-	-
Capacitor	C1,C3,C8,C9	CAP,10μF,16V,±20%,SMD	4	-	-
Capacitor	C2	CAP,10nF,16V,±20%,SMD	1	-	-
Capacitor	C4,C6,C7	CAP,0.1μF,16V,±20%,SMD	3	-	-
Capacitor	C5	CAP,22μF,25V,±20%,SMD	1	-	-
Capacitor	C10	CAP,1μF,16V,±20%,SMD	1	-	-

Table 2: Bill of Materials. Refer to Figure 2 for additional information.

# IS31BL3231 Flash LED Driver Evaluation Board Guide

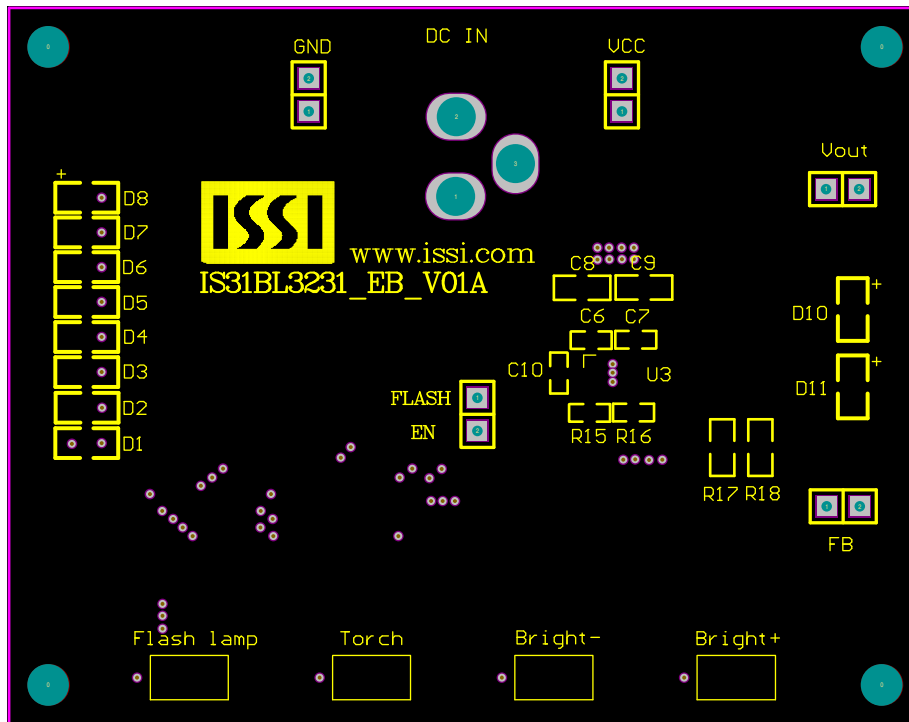

Figure 3: Board Component Placement Guide -Top Layer

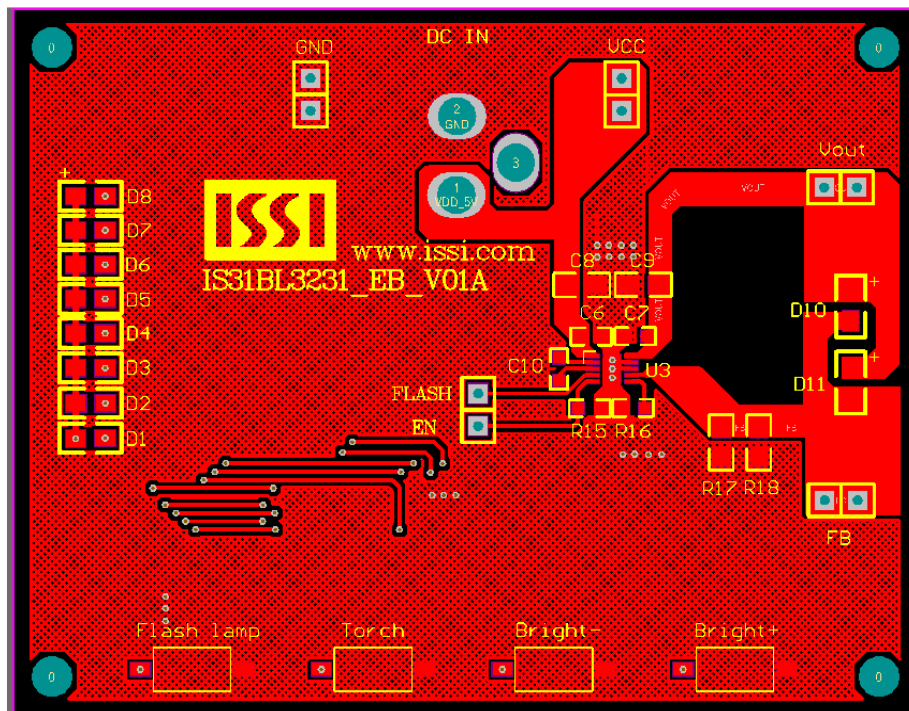

Figure 4: Board PCB Layout- Top Layer

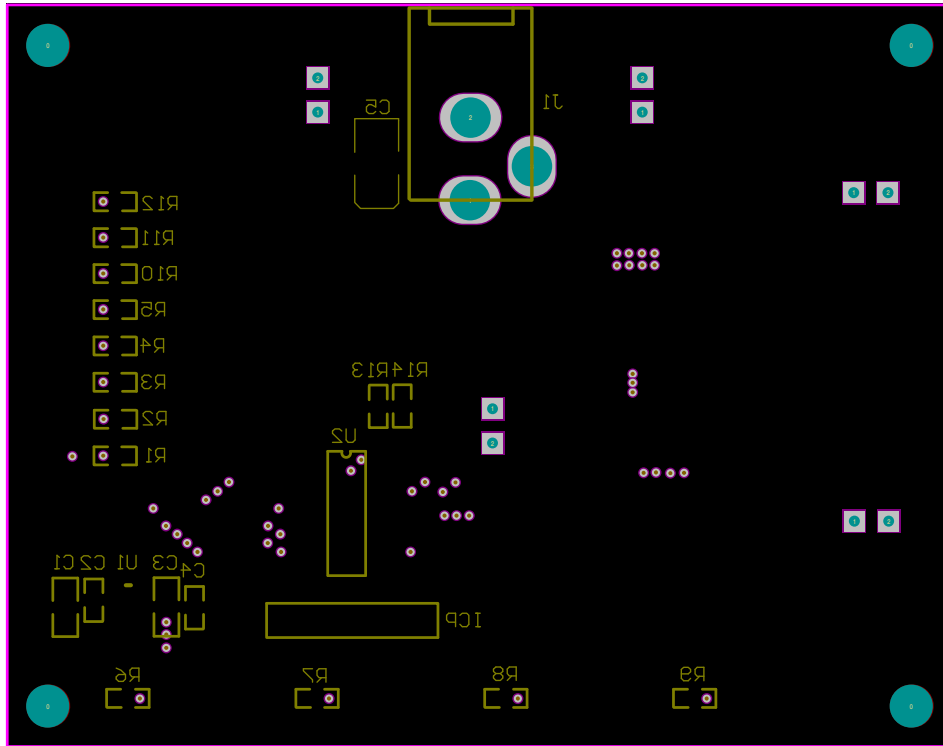

Figure 5: Board Component Placement Guide -Bottom Layer

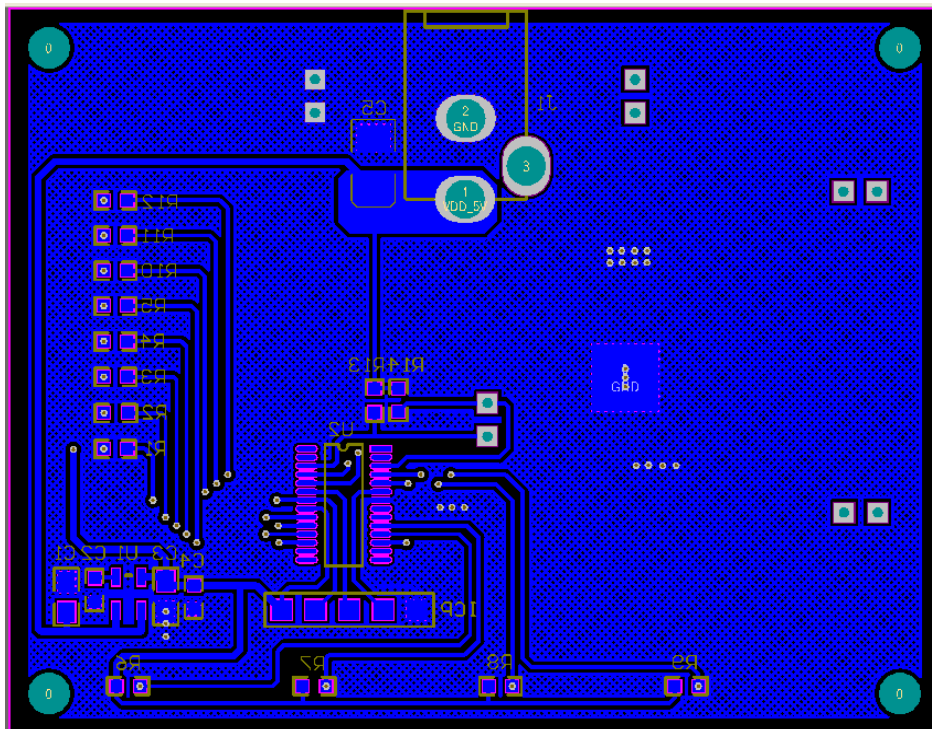

Figure 6: Evaluation Board PCB Layout- Bottom Layer



## IS31BL3231 Flash LED Driver Evaluation Board Guide

---

Copyright © 2011 Integrated Silicon Solution, Inc. All rights reserved. ISSI reserves the right to make changes to this specification and its products at any time without notice. ISSI assumes no liability arising out of the application or use of any information, products or services described herein. Customers are advised to obtain the latest version of this device specification before relying on any published information and before placing orders for products.

Integrated Silicon Solution, Inc. does not recommend the use of any of its products in life support applications where the failure or malfunction of the product can reasonably be expected to cause failure of the life support system or significantly affect its safety or effectiveness. Products are not authorized for use in such applications unless Integrated Silicon Solution, Inc. receives written assurance to its satisfaction, that:

- a.) the risk of injury or damage has been minimized;
- b.) the user assume all such risks; and
- c.) potential liability of Integrated Silicon Solution, Inc is adequately protected under the circumstances.