



Chipsmall Limited consists of a professional team with an average of over 10 year of expertise in the distribution of electronic components. Based in Hongkong, we have already established firm and mutual-benefit business relationships with customers from,Europe,America and south Asia,supplying obsolete and hard-to-find components to meet their specific needs.

With the principle of “Quality Parts,Customers Priority,Honest Operation,and Considerate Service”,our business mainly focus on the distribution of electronic components. Line cards we deal with include Microchip,ALPS,ROHM,Xilinx,Pulse,ON,Everlight and Freescale. Main products comprise IC,Modules,Potentiometer,IC Socket,Relay,Connector.Our parts cover such applications as commercial,industrial, and automotives areas.

We are looking forward to setting up business relationship with you and hope to provide you with the best service and solution. Let us make a better world for our industry!



Contact us

Tel: +86-755-8981 8866 Fax: +86-755-8427 6832

Email & Skype: info@chipsmall.com Web: www.chipsmall.com

Address: A1208, Overseas Decoration Building, #122 Zhenhua RD., Futian, Shenzhen, China



IS31BL3506A Boost Converter LED Backlight Driver Evaluation Board Guide

Description

IS31BL3506A LED driver demo board is used to demonstrate and evaluate the IS31FL3506A. IS31BL3506A is a boost converter featuring an integrated MOSFET switch designed for driving series strings of LED or other device. The device regulates the LED load current is set using an external, low value sensing resistor. The device adjusts the PWM duty cycle of the switch to maintain the voltage at the FB pin at a value of 0.3V.

Features

- Supply voltage range from 2.7V to 5.5V
- Drive series strings of 9 LEDs
- PWM or DC voltage dimming
- Frequency of PWM is 500Hz ~ 500kHz
- 1.0MHz high speed switching frequency
- DFN-8(2mm x 2mm) package

Quick Start

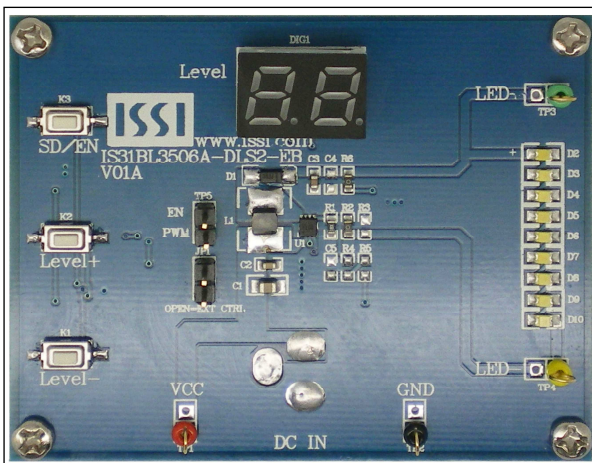

Figure 1: Photo of IS31BL3506A Evaluation Board

Recommended Equipment

- 5.0V, 2A power supply

Absolute Maximum Ratings

- ≤ 5.5V power supply

Caution: Do not exceed the conditions listed above; otherwise the board will be damaged.

Procedure

The IS31BL3506A evaluation board is fully assembled and tested. Follow the steps listed below to verify board operation.

Caution: Do not turn on the power supply until all connections are completed.

- 1) Connect the ground terminal of the power supply to the GND and the positive terminal to the VCC. Or connect the DC power to the connector (DC IN).
- 2) Turn on the power supply and pay attention to the supply current. If the current exceeds 500mA, please check for circuit fault.
- 3) Press Level+ or Level- button to change current of white LEDs, the intensity of LEDs will be in 1 level (lowest) when power on.
- 4) The button (SD/EN) controls the IS31BL3506A Shutdown or Enable.

Evaluation Board Ordering Information

Part No.	IC Package
IS31BL3506A-DLS2-EB	DFN-8, Lead-free

Table1: Ordering Information

For pricing, delivery, and ordering information, please contact ISSI's analog marketing team at analog_mkt@issi.com or (408) 969-6600

IS31BL3506A Boost Converter LED Backlight Driver Evaluation Board Guide

Evaluation Board Operation

The IS31BL3506A evaluation board performs constant output current with PWM dimming control.

The evaluation board uses a MCU generating PWM signal at EN pin adjusting the LEDs current. The current level is displayed by Dual Digit Display.

***Note:**
IS31BL3506A solely controls the white LEDs function on the evaluation board.

Software Support

***Note:**
JP1 is set to close circuit by default. If it is set to open, the on-board MCU will stop working. The MCU pin which drives the EN pin of the LED driver will be set to High Impedance. An external driving signal can be connected to the TP5 connecting point to control the IS31BL3506A LED driver.

Refer to the datasheet to get more information about IS31BL3506A.

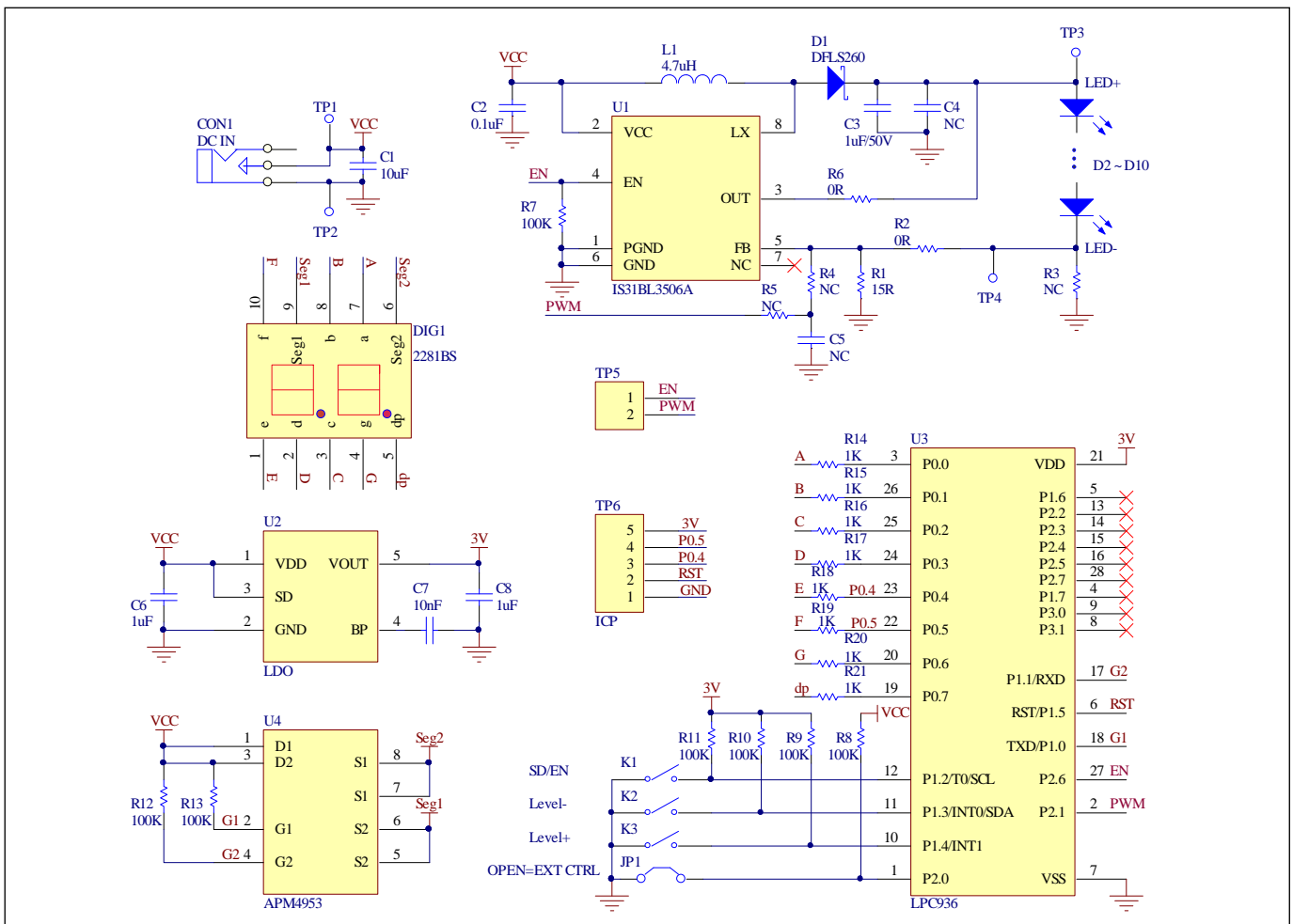

Figure 2: IS31BL3506A Application Schematic



IS31BL3506A Boost Converter LED Backlight Driver Evaluation Board Guide

Bill of Materials

Name	Symbol	Description	Qty	Supplier	Part No.
LED Driver	U1	Boost Converter LED Driver	1	ISSI	IS31BL3506A
LDO	U2	Low-dropout Regulator	1	PAM	PAM3101
MCU	U3	Microcontroller	1	NXP	LPC936
PMOS	U4	Dual PMOS	1	ANPEC	APM4953
Display	DIG1	Dual Digit Display Common Anode	1	ZSO	2281BS
Diode	D1	Schottky Diode, SMD	1		DFLS260
Diodes	D2~D10	Diode, LED White, SMD	9	Everlight	EHP-C04/UT01-P01/TR
Inductor	L1	IND,4.7 μ H \pm 20%,SMD	1	Microgate	4.7uH,IND
Resistor	R1	RES,15R,1/16W, \pm 5%,SMD	1		
Resistors	R2,R6	RES,0R,1/16W, \pm 5%,SMD	2		
	R3,R4,R5,C4,C5	Not Connect	5		
Resistors	R7~R13	RES,100k,1/16W, \pm 5%,SMD	7		
Resistors	R14~R21	RES,1k,1/16W, \pm 5%,SMD	8		
Capacitor	C1	CAP,10 μ F,16V, \pm 20%,SMD	1		
Capacitor	C2	CAP, 0.1 μ F,16V, \pm 20%,SMD	1		
Capacitors	C3,C6,C8	CAP,1 μ F,50V, \pm 20%,SMD	3		
Capacitor	C7	CAP,10nF,16V, \pm 20%,SMD	1		
Buttons	K1~K3	Button SMD	3		

Table 2: Bill of Materials, refer to Figure 2 above.

IS31BL3506A Boost Converter LED Backlight Driver Evaluation Board Guide

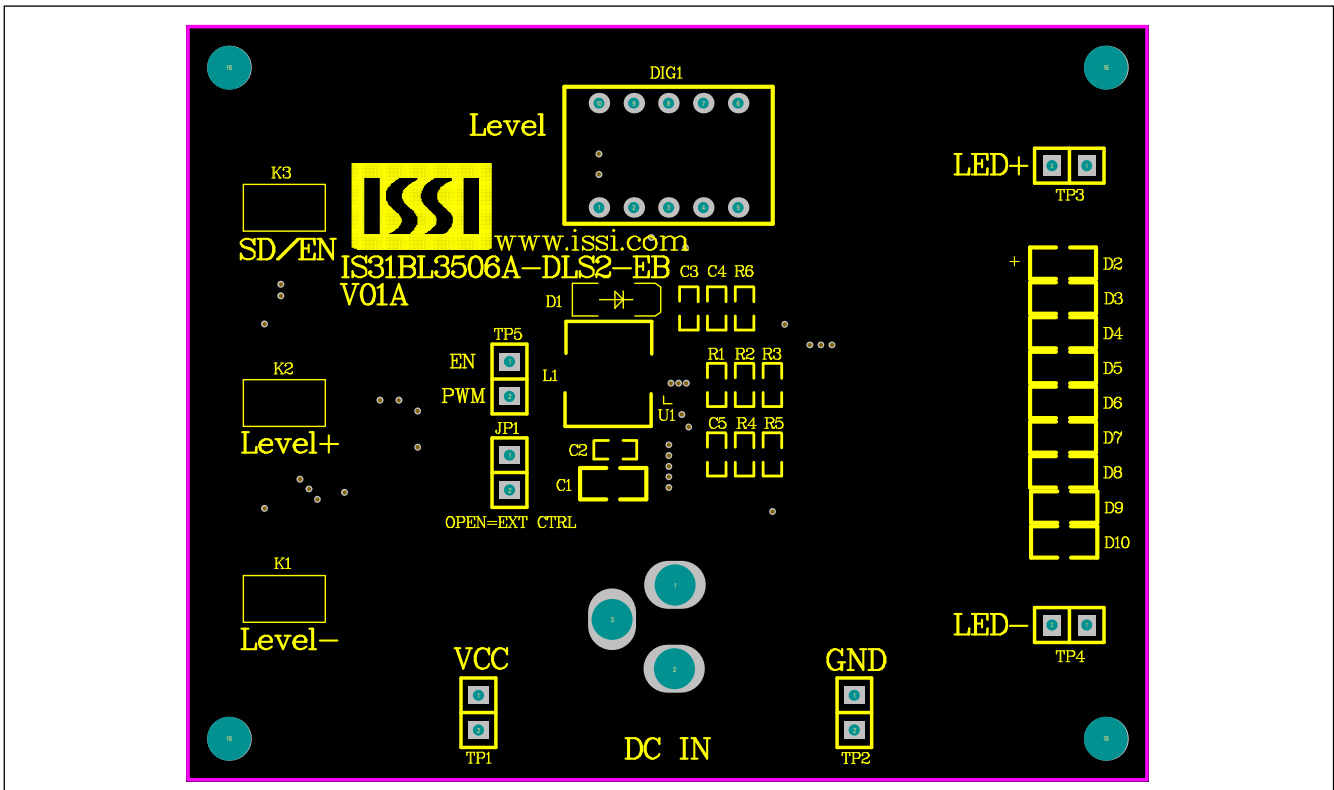

Figure 3: Board Component Placement Guide -Top Layer

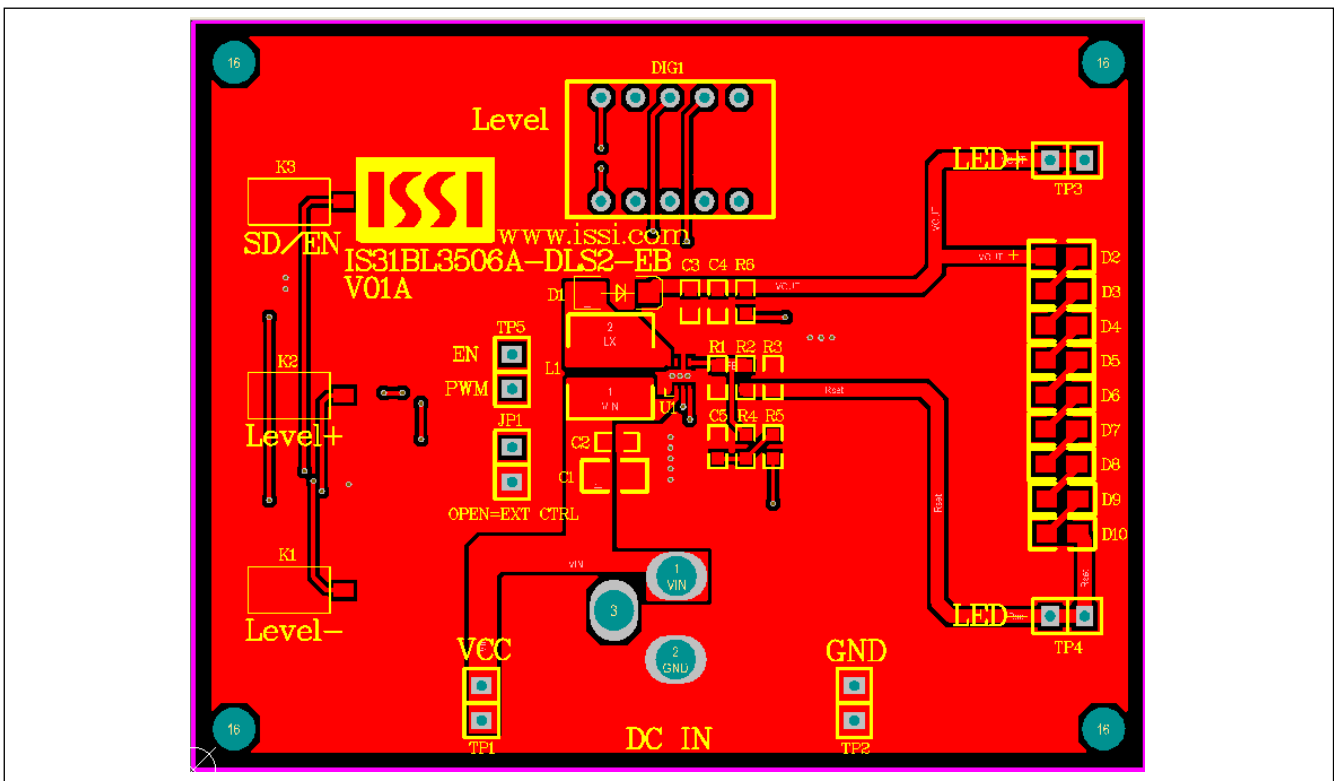

Figure 4: Board PCB Layout- Top Layer

IS31BL3506A Boost Converter LED Backlight Driver Evaluation Board Guide

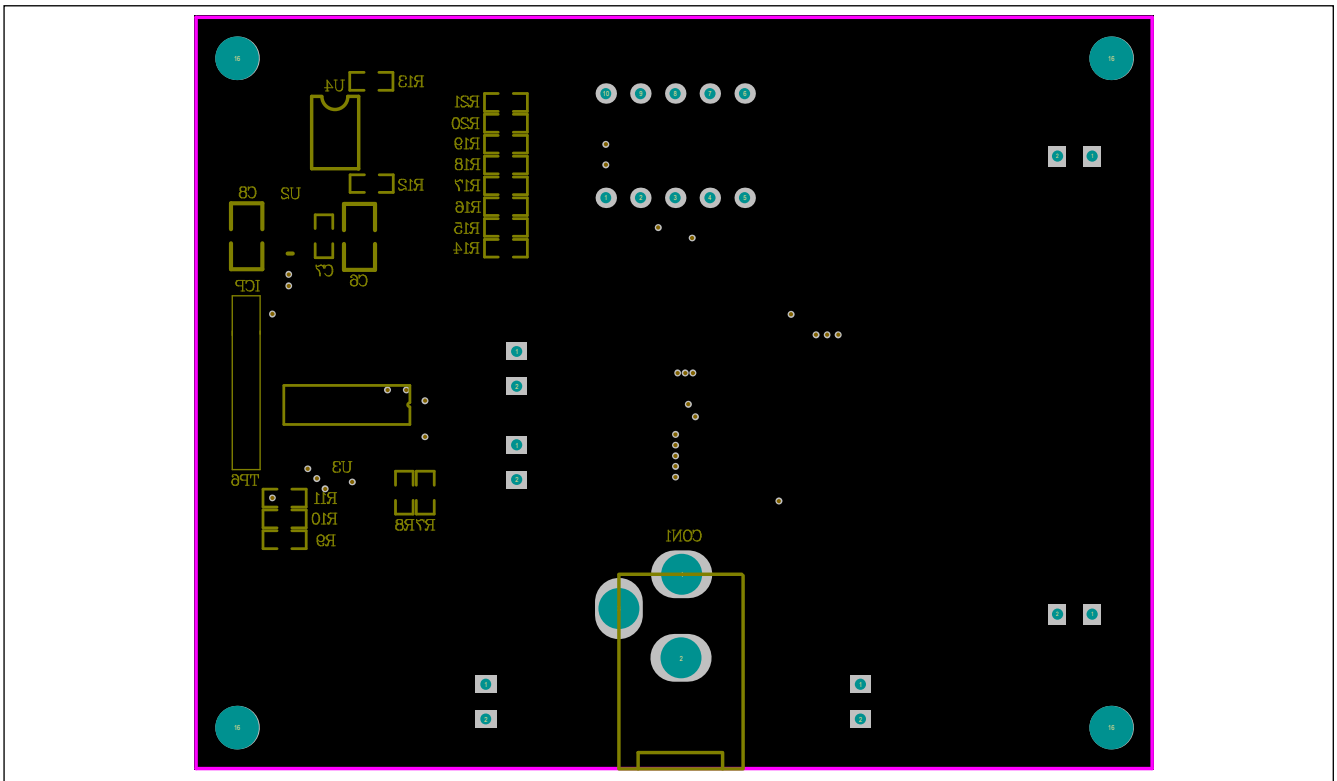

Figure 5: Board Component Placement Guide -Bottom Layer

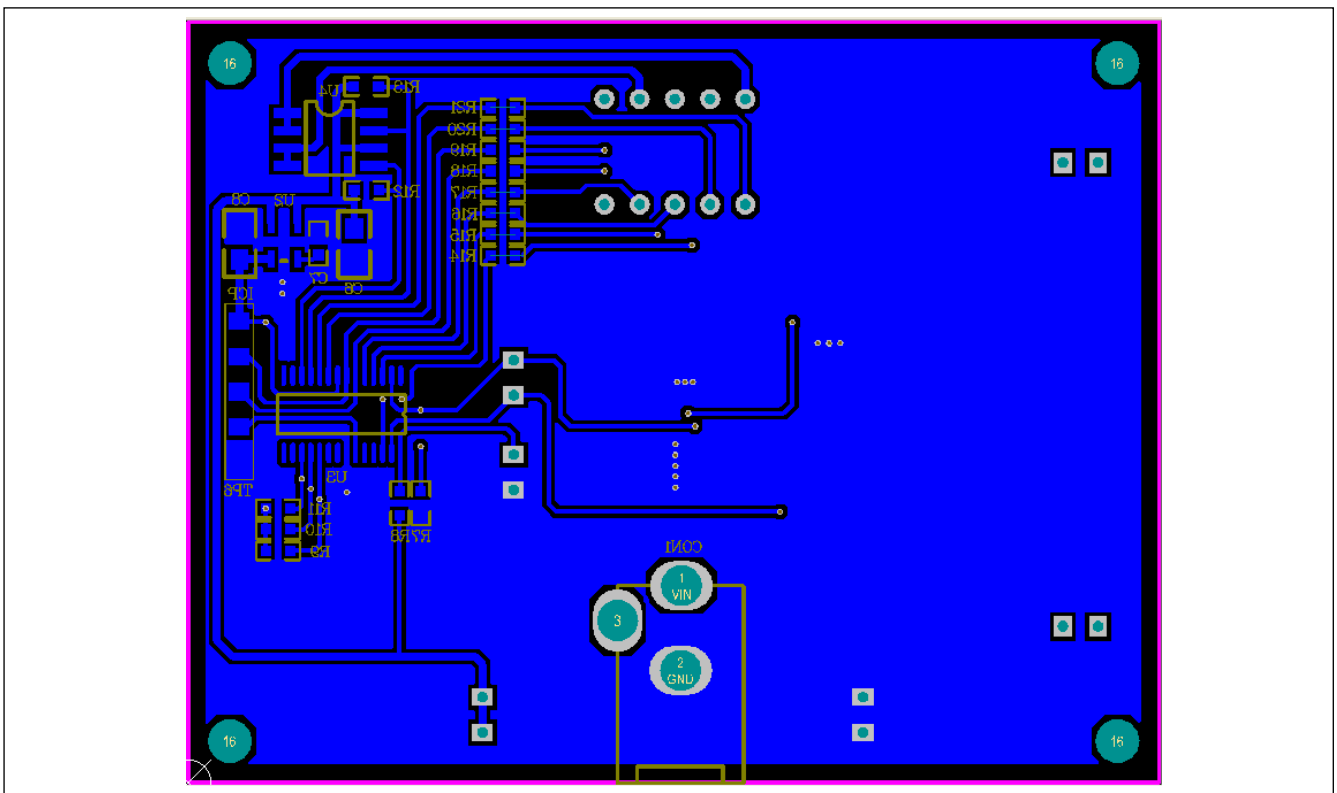

Figure 6: Board PCB Layout-Bottom Layer



IS31BL3506A Boost Converter LED Backlight Driver Evaluation Board Guide

Copyright © 2011 Integrated Silicon Solution, Inc. All rights reserved. ISSI reserves the right to make changes to this specification and its products at any time without notice. ISSI assumes no liability arising out of the application or use of any information, products or services described herein. Customers are advised to obtain the latest version of this device specification before relying on any published information and before placing orders for products.

Integrated Silicon Solution, Inc. does not recommend the use of any of its products in life support applications where the failure or malfunction of the product can reasonably be expected to cause failure of the life support system or to significantly affect its safety or effectiveness. Products are not authorized for use in such applications unless Integrated Silicon Solution, Inc. receives written assurance to its satisfaction, that:

- a.) the risk of injury or damage has been minimized;
- b.) the user assume all such risks; and
- c.) potential liability of Integrated Silicon Solution, Inc is adequately protected under the circumstances