



Chipsmall Limited consists of a professional team with an average of over 10 year of expertise in the distribution of electronic components. Based in Hongkong, we have already established firm and mutual-benefit business relationships with customers from,Europe,America and south Asia,supplying obsolete and hard-to-find components to meet their specific needs.

With the principle of “Quality Parts,Customers Priority,Honest Operation,and Considerate Service”,our business mainly focus on the distribution of electronic components. Line cards we deal with include Microchip,ALPS,ROHM,Xilinx,Pulse,ON,Everlight and Freescale. Main products comprise IC,Modules,Potentiometer,IC Socket,Relay,Connector.Our parts cover such applications as commercial,industrial, and automotives areas.

We are looking forward to setting up business relationship with you and hope to provide you with the best service and solution. Let us make a better world for our industry!



Contact us

Tel: +86-755-8981 8866 Fax: +86-755-8427 6832

Email & Skype: info@chipsmall.com Web: www.chipsmall.com

Address: A1208, Overseas Decoration Building, #122 Zhenhua RD., Futian, Shenzhen, China



Description

IS31FL3193 3-channel LED driver demo board is used to demonstrate and evaluate the IS31FL3193. IS31FL3193 is a constant current LED driver featuring One Shot Program Mode and PWM Control Mode for RGB lighting effects. The IS31FL3193 can drive three LEDs or one group RGB LED.

The demo board can perform breathing effect in One Shot Programming Mode to display the function of IS31FL3193.

Features

- Voltage range from 3.5V to 5.5V
- One group RGB LED or three single color LEDs breathing system-free pre-established pattern
- 3 independently controlled outputs of 256 PWM steps
- I2C interface, automatic address increment function
- Available in DFN-10 (3mm × 3mm) package

Quick Start

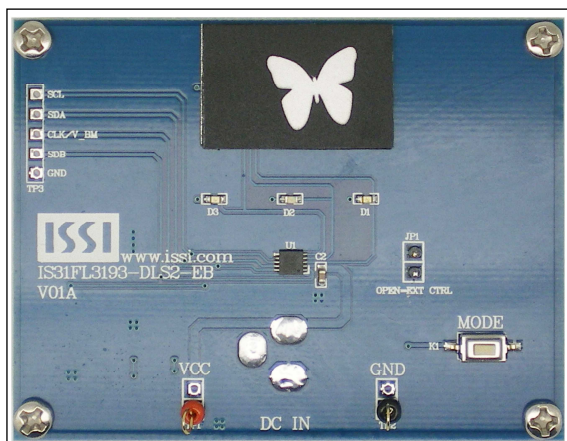

Figure 1: Photo of IS31FL3193 Evaluation Board

Recommended Equipment

- 5.0V, 2A power supply

Absolute Maximum Ratings

- ≤ 5.5V power supply

Caution: Do not exceed the conditions listed above, otherwise the board will be damaged.

Procedure

The IS31FL3193 evaluation board is fully assembled and tested. Follow the steps listed below to verify board operation.

Caution: Do not turn on the power supply until all connections are completed.

- 1) Connect the ground terminal of the power supply to the GND and the positive terminal to the VCC. Or connect the DC power to the connector (DC IN).
- 2) Turn on the power supply and pay attention to the supply current. If the current exceeds 300mA, please check for circuit fault.
- 3) Enter the desired mode of display by toggling the MODE button.

Evaluation Board Ordering Information

Part No.	IC Package
IS31FL3193-DLS2-EB	QFN-20, Lead-free

Table1: Ordering Information

For pricing, delivery, and ordering information, please contact ISSI's analog marketing team at analog_mkt@issi.com or (408) 969-6600.

Evaluation Board Operation

The IS31FL3193 evaluation board has three display modes. Press MODE button to switch configurations.

- 1) One-Shot Program Mode is set by default to function as a RGB unit exhibiting identical breathing patterns. There are twenty possible colors within the LED's breathing range color spectrum.
- 2) In automatic mode, the LED's will function as a RGB display with automatic color changing patterns.
- 3) In third configuration, three LED's will brighten individually and exhibit unique behaviors.

***Note:**

IS31FL3193 solely controls the FxLED function on the evaluation board.

Software Control

JP1 default setting is close circuit. If it is set to open, the on-board MCU will stop working. The I2C pins are set to High Impedance. External I2C signals can be connected to TP3 to control the IS31FL3193 LED driver.

Please refer to the datasheet to get more information about IS31FL3193.

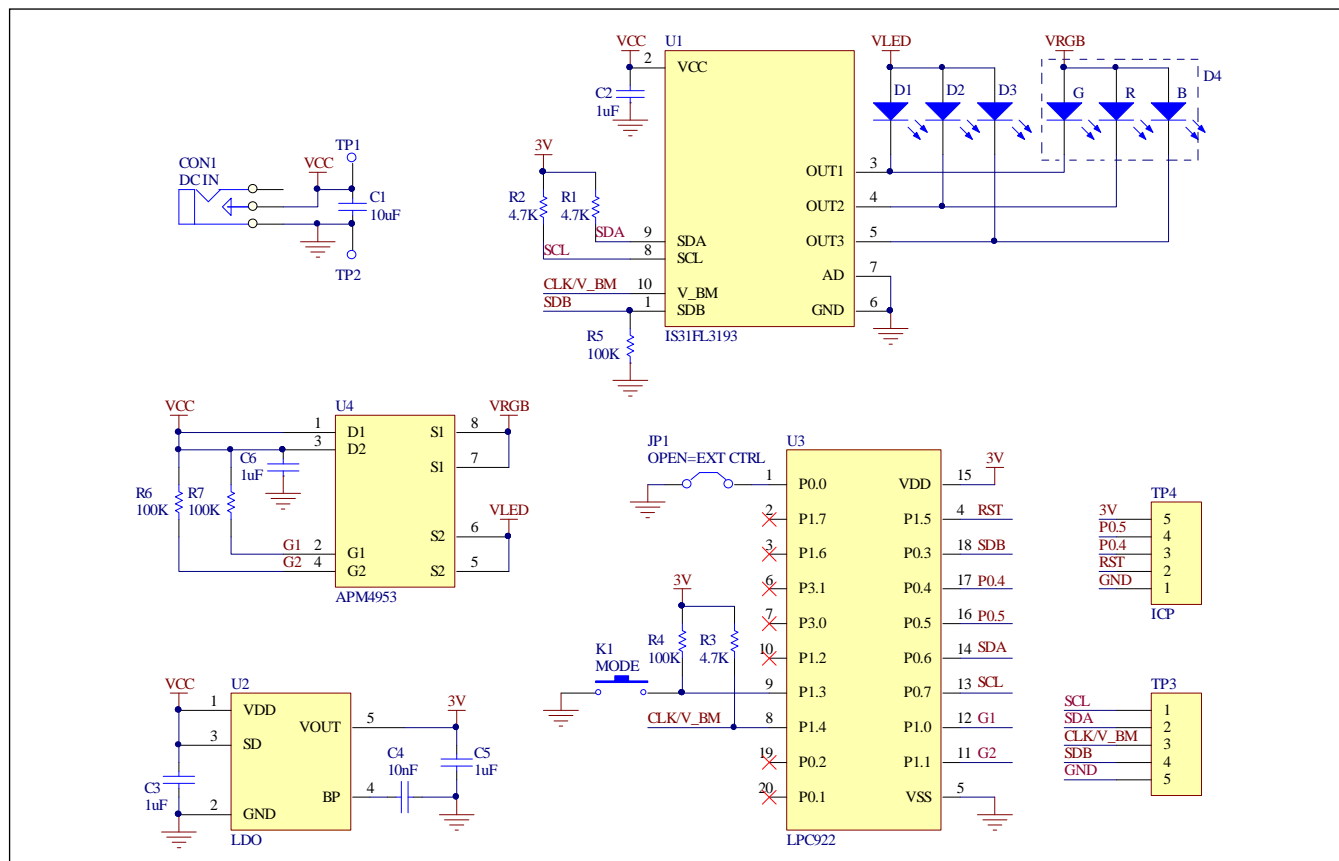

Figure 2: IS31FL3193 Application Schematic

Bill of Materials

Name	Symbol	Description	Qty	Supplier	Part No.
LED Driver	U1	3CH FxLED Driver	1	ISSI	IS31FL3193
LDO	U2	Low-dropout Regulator	1	PAM	PAM3101
MCU	U3	Microcontroller	1	NXP	LPC922
PMOS	U4	Dual PMOS	1	ANPEC	APM4953
Diode	D1	Diode, LED Red, SMD	1	Everlight	19-217/BHC-ZL 1M2RY/3T
Diode	D2	Diode, LED Green, SMD	1	Everlight	19-217/BHC-ZL 1M2RY/3T
Diode	D3	Diode, LED Blue, SMD	1	Everlight	EHP-C04/UT01- P01/TR
Diode	D4	Diode, LED RGB, SMD	1	Everlight	99-235/RGBC/T R8
Resistors	R1~R3	RES,4.7k,1/16W,±5%,SMD	3		
Resistors	R4~R7	RES,100k,1/16W,±5%,SMD	4		
Capacitor	C1	CAP,10µF,16V,±20%,SMD	1		
Capacitors	C2,C3,C5,C6	CAP, 1µF,16V,±20%,SMD	2		
Capacitor	C4	CAP,10nF,16V,±20%,SMD	1		
Button	K1	Button SMD	1		

Table 2: Bill of Materials, refer to Figure 2 above.

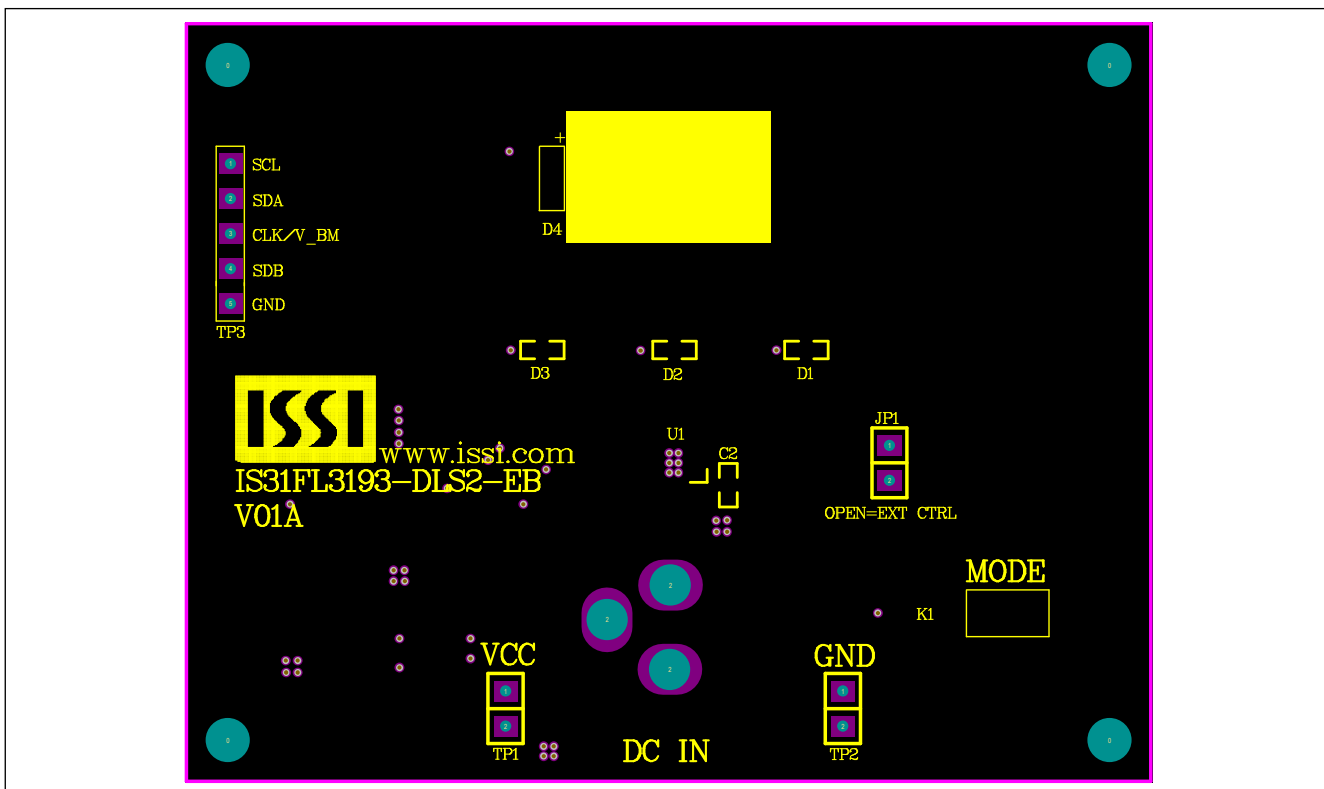

Figure 3: Board Component Placement Guide -Top Layer

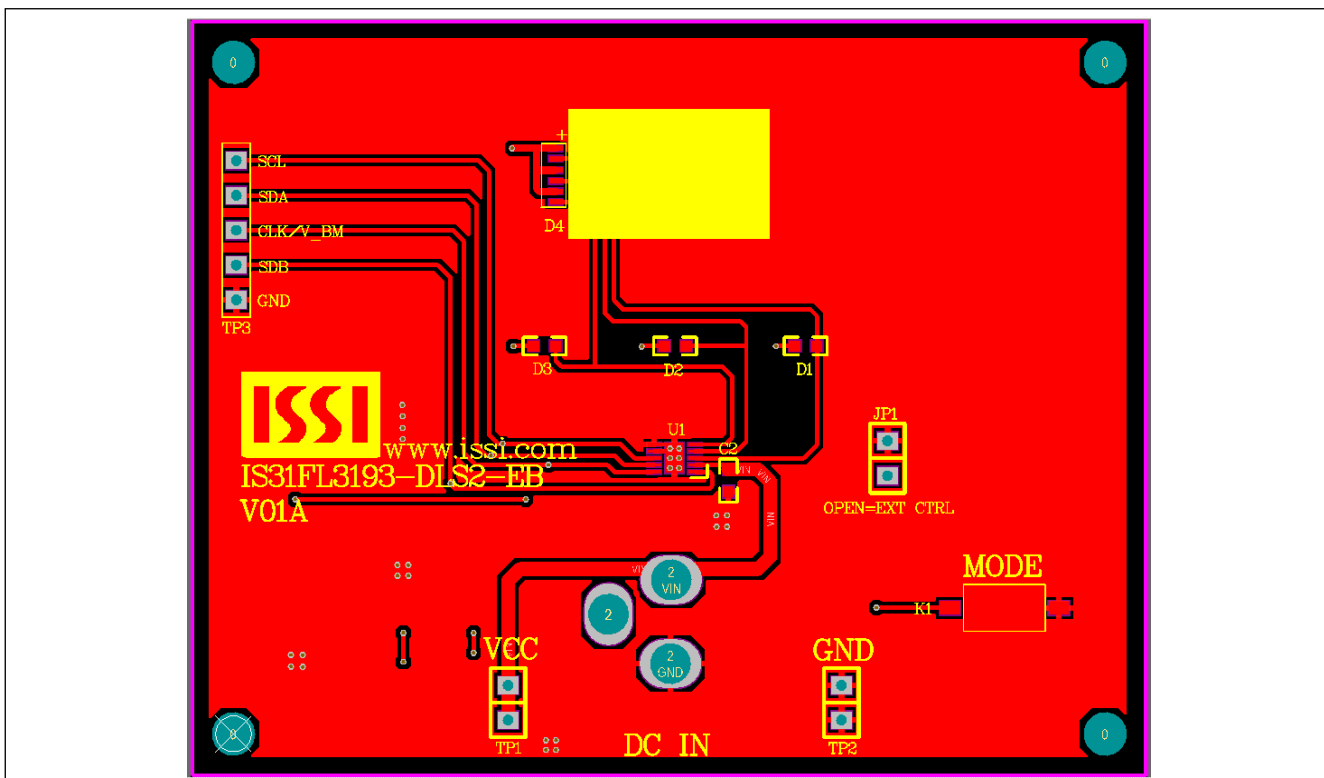

Figure 4: Board PCB Layout- Top Layer

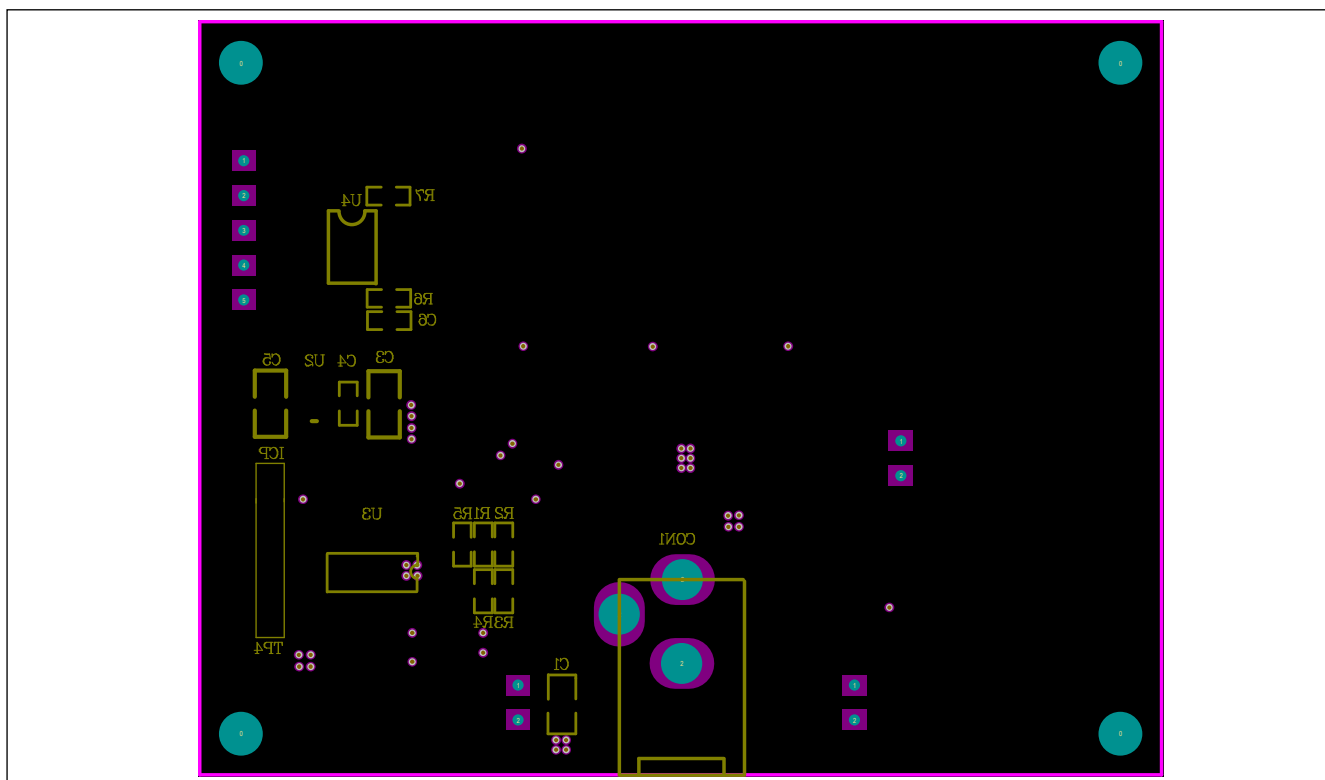

Figure 5: Board Component Placement Guide -Bottom Layer

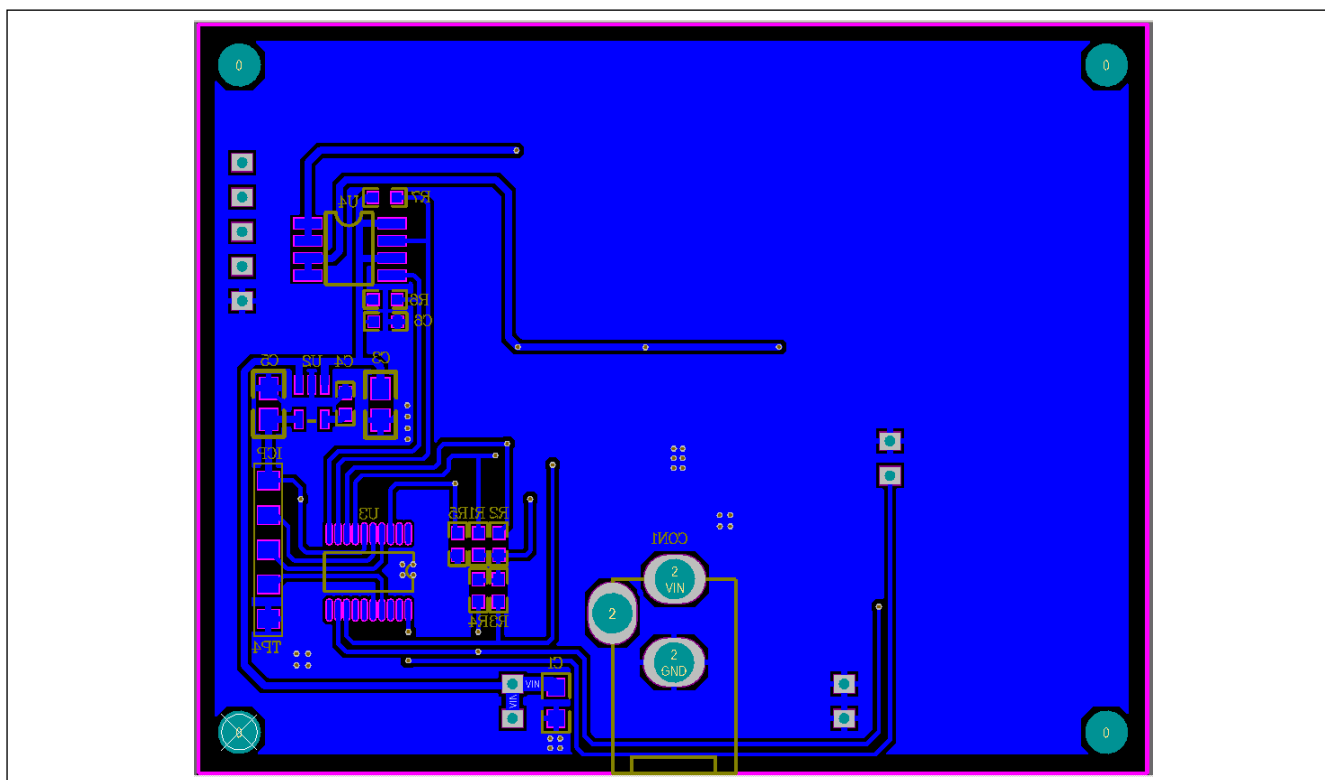

Figure 6: Board PCB Layout-Bottom Layer



IS31FL3193 3-Channel Fun LED Driver Evaluation Board Guide

Copyright © 2011 Integrated Silicon Solution, Inc. All rights reserved. ISSI reserves the right to make changes to this specification and its products at any time without notice. ISSI assumes no liability arising out of the application or use of any information, products or services described herein. Customers are advised to obtain the latest version of this device specification before relying on any published information and before placing orders for products.

Integrated Silicon Solution, Inc. does not recommend the use of any of its products in life support applications where the failure or malfunction of the product can reasonably be expected to cause failure of the life support system or to significantly affect its safety or effectiveness. Products are not authorized for use in such applications unless Integrated Silicon Solution, Inc. receives written assurance to its satisfaction, that:

- a.) the risk of injury or damage has been minimized;
- b.) the user assume all such risks; and
- c.) potential liability of Integrated Silicon Solution, Inc is adequately protected under the circumstances