



Chipsmall Limited consists of a professional team with an average of over 10 year of expertise in the distribution of electronic components. Based in Hongkong, we have already established firm and mutual-benefit business relationships with customers from,Europe,America and south Asia,supplying obsolete and hard-to-find components to meet their specific needs.

With the principle of “Quality Parts,Customers Priority,Honest Operation,and Considerate Service”,our business mainly focus on the distribution of electronic components. Line cards we deal with include Microchip,ALPS,ROHM,Xilinx,Pulse,ON,Everlight and Freescale. Main products comprise IC,Modules,Potentiometer,IC Socket,Relay,Connector.Our parts cover such applications as commercial,industrial, and automotives areas.

We are looking forward to setting up business relationship with you and hope to provide you with the best service and solution. Let us make a better world for our industry!



Contact us

Tel: +86-755-8981 8866 Fax: +86-755-8427 6832

Email & Skype: info@chipsmall.com Web: www.chipsmall.com

Address: A1208, Overseas Decoration Building, #122 Zhenhua RD., Futian, Shenzhen, China



IS31LT3354 Evaluation Board Guide

Description

The IS31LT3354 is a continuous mode inductive step-down converter, designed for driving a single LED or multiple series connected LEDs efficiently from a voltage source higher than the required LED voltage. The device operates from an input supply between 6V and 40V and provides an externally adjustable output current of up to 2A or even higher, which is determined by the external MOSFET and inductor.

The IS31LT3354 includes a high-side output current sensing circuit, which uses an external resistor to set the nominal average output current.

Output current can be adjusted linearly by applying an external control signal to the ADJ pin. The ADJ pin will accept either a DC voltage or a PWM waveform. This will provide either a continuous or a gated output current.

Applying a voltage of 0.2V or lower to the ADJ pin turns the output off and switches the chip into a low current standby state.

The chip is assembled in SOT23-5 package.

Features

- Simple low parts count
- Wide input voltage range: 6V to 40V
- Output Current only limited by external component selection
- High efficiency (up to 98%)
- Typical 1200:1 dimming ratio
- Typical 5% output current accuracy
- Single pin on/off and brightness control using DC voltage or PWM
- Up to 1MHz switching frequency
- Inherent open-circuit LED protection
- Thermal shutdown protection circuitry

Applications

- Low voltage halogen replacement LEDs
- Automotive lighting
- Low voltage industrial lighting
- LED back-up lighting
- Illuminated sign

Quick Start

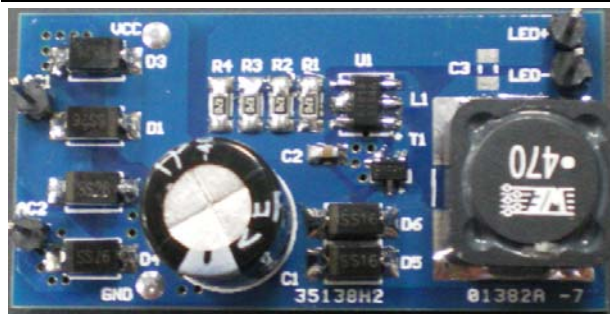

Recommended Equipment

- Power supply
- LED panel (LED arrays)

Absolute Maximum Ratings

- $\leq 30V$ power supply

Caution: Do not exceed the conditions listed above, otherwise the board will be damaged.

Procedure

The IS31LT3354 Evaluation Board is fully assembled and tested. Follow the steps listed below to verify board operation.

Caution: Do not turn on the power supply until all connections are completed.

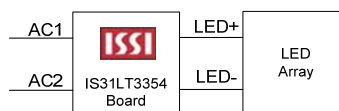

- 1) Connect the two terminals of the power supply to the AC1 and AC2 pin.
- 2) Connect the negative of the LED panel (LED arrays) to the LED- terminal.
- 3) Connect the positive of the LED panel (LED arrays) to the LED+ terminal.
- 4) Turn on the power supply and the LED panel (LED arrays) will be light.

Ordering Information

PART #	TEMP RANGE	IC PACKAGE
IS31LT3354_STLS2_EBDCDC	-40°C to 85°C	SOT23-5 (3.0 x 3.0mm)

For pricing, delivery, and ordering information, please contact ISSI at analog_mkt@issi.com or call +1-408-969-6600

IS31LT3354 Evaluation Board Guide

Detailed Description

LED Current Control

The nominal average output current in the LED(s) is determined by the value of the external current sense resistor (R_S) connected between V_{IN} and I_{SENSE} and in is given by: $I_{OUT\ nom} = 0.1/R_S$

The table below gives values of nominal average output current for several preferred values of current setting resistor (R_S) in the application circuit:

R_S (Ω)	Nominal average output current (mA)
0.05	2000
0.083	1200
0.15	667
0.3	333

The above values assume that the ADJ pin is floating and at a nominal voltage of $V_{REF} = 1.2V$. It is possible to use different values of R_S if the ADJ pin is driven from an external voltage. R_S need to be chosen 1% accuracy resistor with enough power tolerance and good temperature characteristic to ensure stable output current.

Inductor selection

Recommended inductor values are in the range 47 μ H to 220 μ H. Higher values of inductance are recommended at higher supply voltages and low output current in order to minimize errors due to switching delays, which result in increased ripple and lower efficiency. Higher values of inductance also result in a smaller change in output current over the supply voltage range. The inductor should be mounted as close to the MOSFET as possible with low resistance connections to the drain and V_{IN} pins.

Switch MOSFET selection

The IS31LT3354 demands a power N-MOSFET as a switch.

The voltage and current rating of the MOSFET must be higher than the application output voltage and the inductor peak current. The $V_{GS(th)}$ of MOSFET should be lower than 3V and the $R_{DS(on)}$ should be as lower as possible for maximum efficiency and performance. AP2306 and AP2310 are recommended.

NOTE: For the recommended MOSFET's the maximum load current is about 2A. For high current applications, the operating input voltage, the LED current, and the switching frequency will determine the operating temperature of the MOSFET. Switching frequency can be lowered by choosing a larger value of inductance, however, the MOSFET specifications must be carefully analyzed prior to selecting the external MOSFET. Key specifications to consider are $R_{DS(on)}$ and C_{DS} , both should be as low as possible.

PCB layout consideration

- The Drain of the external MOSFET is a fast switching node, so PCB traces should be kept as short as possible. To minimize ground 'bounce', the ground pin of the chip should be soldered directly to the ground plane.
- It is particularly important to mount the coil and the input decoupling capacitor close to the chip to minimize parasitic resistance and inductance, which will degrade efficiency. It is also important to take account of any trace resistance in series with current sense resistor R_S .
- The ADJ pin is a high impedance input, so when left floating, PCB traces to this pin should be as short as possible to reduce noise pickup. ADJ pin can also be connected to a voltage between 1.2V~5V. In this case, the internal circuit will clamp the output current at the value which is set by ADJ=1.2V.
- Avoid running any high voltage traces close to the ADJ pin, to reduce the risk of leakage due to board contamination. Any such leakage may raise the ADJ pin voltage and cause excessive output current. A ground ring placed around the ADJ pin will minimize changes in output current under these conditions

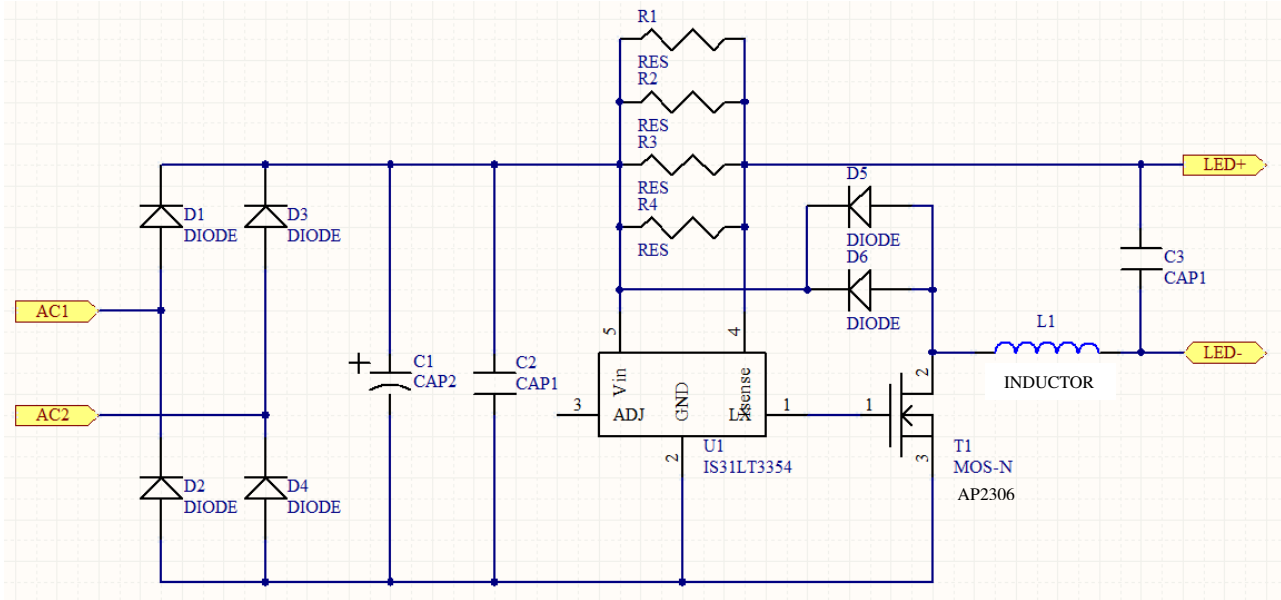

Figure 1 IS31LT3354 Evaluation Board Schematic

Bill of Materials

No.	Name	Description	Ref. Des.	Qty.	MFR P/N
1	Capacitor	220µF±10% 50V	C1	1	
2	Capacitor (0805)	0.1µF±10% 50V	C2	1	
3	Capacitor (0805)	1µF±10% 50V	C3	1	
4	Resistor (1206)	0.24Ω±1%	R1,R2,R3,R4	4	
5	Schottky Diode	SS26(2A/60V)	D1,D2,D3,D4	4	
6	Schottky Diode	SS16(1A/60V)	D5,D6	2	
7	Inductor	47µH, Isat>3A	L1	1	
8	NMOS	AP2306(5A/30V)	T1	1	
9	U??	IS31LT3354(SOT23-5)	U1	1	

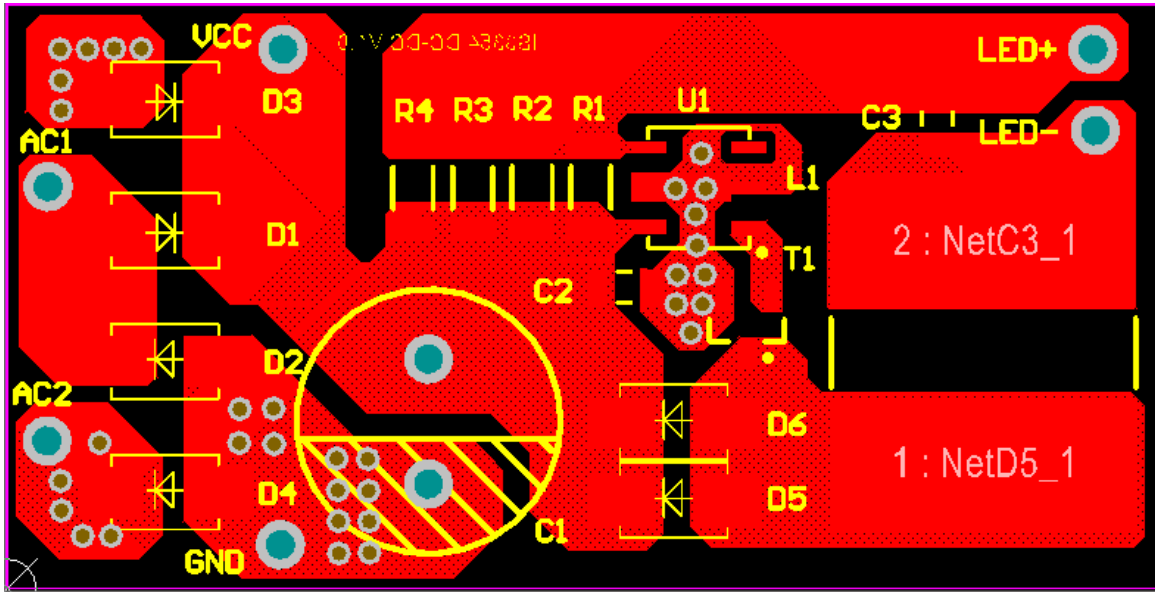

Figure 2 Evaluation Board PCB Layout- Top Layer

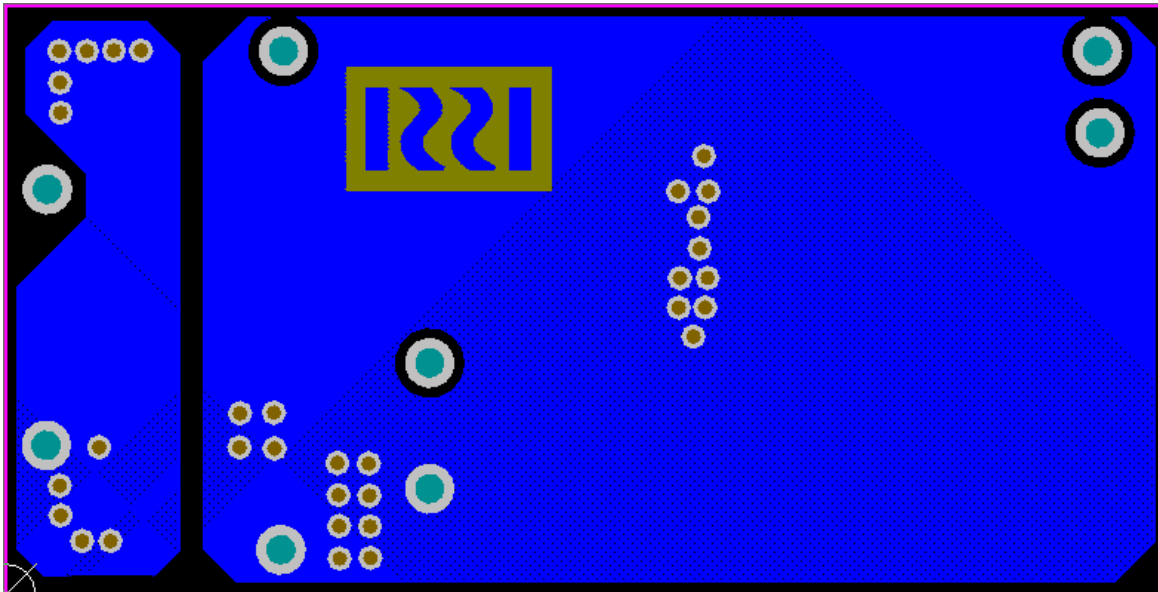

Figure 3 Evaluation Board PCB Layout-Bottom Layer

Copyright © 2011 Integrated Silicon Solution, Inc. All rights reserved. ISSI reserves the right to make changes to this specification and its products at any time without notice. ISSI assumes no liability arising out of the application or use of any information, products or services described herein. Customers are advised to obtain the latest version of this device specification before relying on any published information and before placing orders for products.

Integrated Silicon Solution, Inc. does not recommend the use of any of its products in life support applications where the failure or malfunction of the product can reasonably be expected to cause failure of the life support system or to significantly affect its safety or effectiveness. Products are not authorized for use in such applications unless Integrated Silicon Solution, Inc. receives written assurance to its satisfaction, that:

- a.) the risk of injury or damage has been minimized;
- b.) the user assume all such risks; and
- c.) potential liability of Integrated Silicon Solution, Inc is adequately protected under the circumstance