



Chipsmall Limited consists of a professional team with an average of over 10 year of expertise in the distribution of electronic components. Based in Hongkong, we have already established firm and mutual-benefit business relationships with customers from,Europe,America and south Asia,supplying obsolete and hard-to-find components to meet their specific needs.

With the principle of “Quality Parts,Customers Priority,Honest Operation,and Considerate Service”,our business mainly focus on the distribution of electronic components. Line cards we deal with include Microchip,ALPS,ROHM,Xilinx,Pulse,ON,Everlight and Freescale. Main products comprise IC,Modules,Potentiometer,IC Socket,Relay,Connector.Our parts cover such applications as commercial,industrial, and automotives areas.

We are looking forward to setting up business relationship with you and hope to provide you with the best service and solution. Let us make a better world for our industry!



Contact us

Tel: +86-755-8981 8866 Fax: +86-755-8427 6832

Email & Skype: info@chipsmall.com Web: www.chipsmall.com

Address: A1208, Overseas Decoration Building, #122 Zhenhua RD., Futian, Shenzhen, China



IS31LT3910 T8 Evaluation Board Guide

Description

The IS31LT3910 is a peak current mode control LED driver IC. The IS31LT3910 operates in constant off-time mode. It allows efficient operation of High Brightness (HB) LEDs with voltage sources ranging from 8VDC to 450VDC or 110VAC/220VAC. The IS31LT3910 includes a PWM dimming input that can accept an external control signal with a duty ratio of 0 - 100% and a frequency of up to a few kilohertz. It also includes a 50 - 240mV linear dimming input which can be used either for linear dimming or for temperature compensation of the LED current. The IS31LT3910 is ideally suited for buck LED drivers. Since the IS31LT3910 operates in peak current mode control, the controller achieves good output current regulation without the need for any loop compensation. It achieves good PWM dimming response because the response time is limited only by the rate of rise and fall of the inductor current, enabling very fast rise and fall time.

Features

- Wide input range from 8VDC to 450VDC or 110VAC/220 VAC
- Temperature compensation to regulate LED current
- Application from a few mA to more than 1A output
- Constant off-time operation
- Linear and PWM dimming capability
- Requires few external components for operation

Applications

- DC/DC or AC/DC LED driver applications
- General purpose constant current source
- Signal and decorative LED lighting
- Backlighting LED driver

Quick Start

Recommended Equipment

- 90~240VAC/50~60Hz power supply
- LEDs (12 in series and 24 in parallel)
- Multimeter

Absolute Maximum Ratings

- ≤ 265 VAC power supply
- ≤ 42 V Vout (Total Vf)

Caution: Do not exceed the conditions listed above, otherwise the board will be damaged or the output will be limited.

Procedure

The IS31LT3910 Evaluation Board is fully assembled and tested. Follow the steps listed below to verify board operation.

Caution: Do not turn on the power supply until all connections are completed.

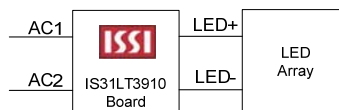

- 1) Connect the positive terminal of the LEDs to the LED+ pin of the DEMO and the negative terminal of the LEDs to the LED- pin of the DEMO.
- 2) Connect the input pins (L and N) of the DEMO to AC power supply.
- 3) Turn on the power supply.

Ordering Information

PART #	TEMP RANGE	IC PACKAGE
IS31LT3910_GRLS2_EBT8	-40 °C to 85°C	SOP-8 (5.0 x 6.0mm)

For pricing, delivery, and ordering information, please contact ISSI at analog_mkt@issi.com or call +1-408-969-6600

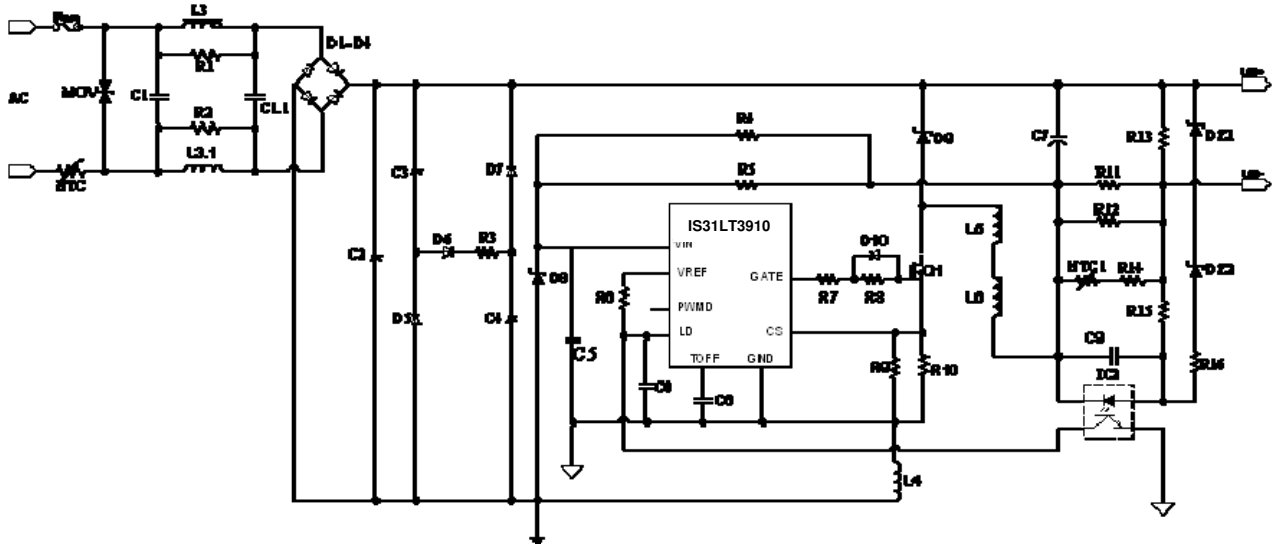

Figure 1. IS31LT3910 Evaluation Board Schematic



Figure 2. Picture of Evaluation Board

NOTE: Physical dimensions are (L x W x H): 28.1mm x 17mm x 12mm

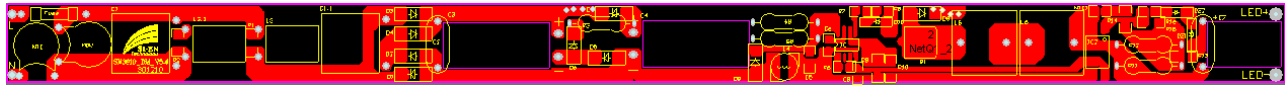

Figure 3. PCB Layout- Top Layer



Figure 4. PCB Layout- Bottom Layer

Line Regulation Rate and Efficiency

Input Voltage	Input Power	PF	Output Voltage	Output Current	Efficiency
AC: 90V	18.45W	0.851	38.42V	0.416A	86.63%
AC: 110V	18.39W	0.886	38.42V	0.420A	87.75%
AC: 130V	18.31W	0.873	38.39V	0.420A	88.06%
AC: 180V	18.37W	0.826	38.37V	0.422A	88.14%
AC: 220V	18.57W	0.809	38.35V	0.422A	87.15%
AC: 240V	18.68W	0.801	38.32V	0.422A	86.57%

Bill of Materials

No.	Name	Description	Ref Des.	Qty.	MFR P/N
1	X Capacitor	0.1uF,275V	C1, C1.1	2	
2	Film Capacitor	10nF,630V	C2	1	
3	AL Capacitor	33uF,100V	C7	1	
4	AL Capacitor	22uF,250V	C3, C4	2	
5	SMD Capacitor	10uF,25V,0805,X7R	C5	1	
6	SMD Capacitor	1uF,25V,0805,X7R	C8	1	
7	SMD Capacitor	390pF,25V,0805,X7R	C6	1	
8	Inductor	3mH,10%,8*10,Isat>100mA	L3, L3.1	2	
9	EE Inductor	0.65mH,Isat≥800mA	L5, L6	2	
10	SMD Inductor	10 uH,Isat≥800mA	L4	1	
11	Zener Diode	6.5V,5%	DZ1	1	
12	Zener Diode	39V,5%	DZ2	1	
13	FR Diode	1A,600V,ESIJ,SMA	D8, D9	1	
14	FR Diode	1N4148	D10	1	
15	Opto-coupler	P521GB	IC2	1	
16	N-MOSFET	4N60,4A,600V,TO-220	Q1	1	
17	Fuse	1A,250V,3*10	Fuse	1	
18	IC	IS31LT3910,SOP-8	IC1	1	
19	Resistor	4.7Ω,1W,1%	R11	1	
20	Resistor	4.7Ω,1W,1%	R12	1	
21	Resistor	220KΩ,1W,1%	R4, R5	2	
22	Resistor	150KΩ,0805,1%	R6	1	
23	Resistor	4.7KΩ,0805,1%	R1, R2	2	
24	Resistor	0.47Ω,0805,1%	R9, R10	2	
25	Resistor	10Ω,0805,1%	R7	2	
26	Resistor	33Ω,0805,1%	R8	2	
27	Resistor	100Ω,0805,1%	R16	2	
28	Resistor	1KΩ,0805,1%	R15	2	
29	Resistor	30K,0805,1%	R13	1	

EMI test

EMI TEST REPORT

Organization: 	Operator: 陈小平	EUT: T8	parameter
Place: 	Time: 2011/2/17/11:7		
Detector: PK+AV	Test-time(ms): 10		
Limit: GB17743	Transducer: PK		
Remark: 220V 12串24并 L线			

Start(MHz)	End(MHz)	Step(MHz)	freq, step
0.009	0.150	0.001	
0.150	3.000	0.002	
3.000	10.000	0.020	
10.000	30.000	0.025	

dBuV scan result

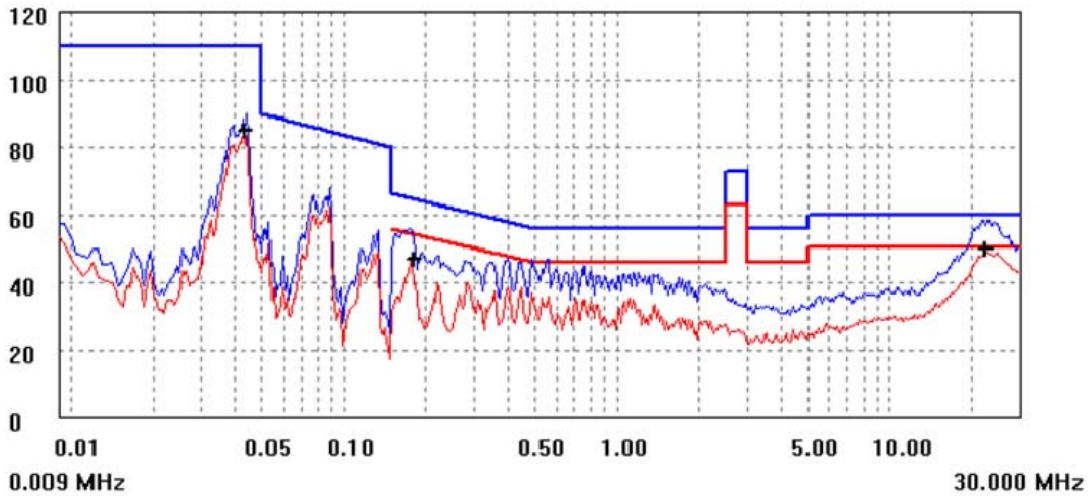

final test

(AV)	freq(MHz)	lev(dBuV)	Lim(dBuV)	Δ (lev-Lim)
	0.043	84.5	0.0	84.5
	0.179	46.6	55.2	-8.6
	22.550	49.7	50.0	-0.3

EMI TEST REPORT

Organization: 	Operator: 陈小平	EUT: T8	parameter
Place:	Time: 2011/2/17/11:11		
Detector: PK+AV	Test-time[ms]: 10		
Limit: GB17743	Transducer: PK		
Remark: 220V 12串24并 N线			

Start(MHz)	End(MHz)	Step(MHz)	freq, step
0.009	0.150	0.001	
0.150	3.000	0.002	
3.000	10.000	0.020	
10.000	30.000	0.025	

dBuV scan result

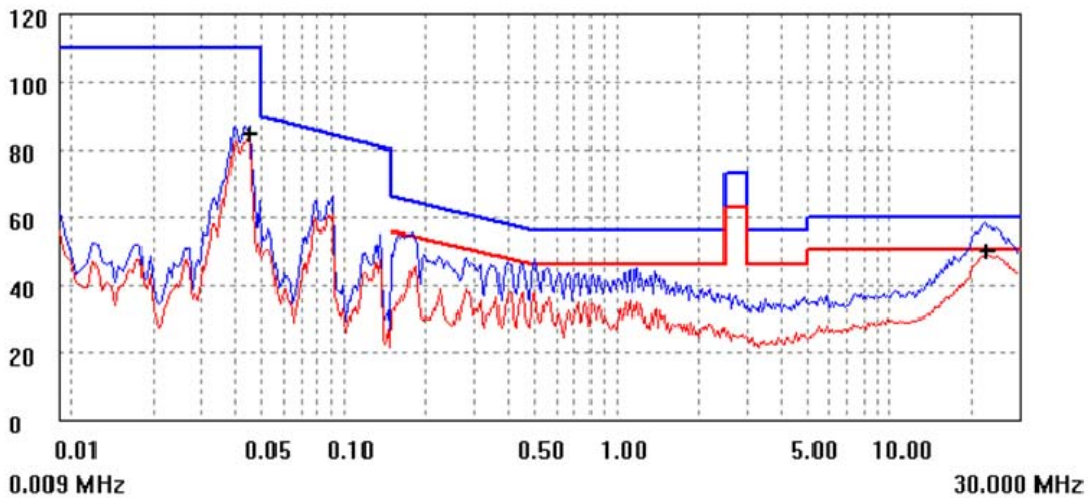

final test

[AV]	freq(MHz)	lev(dBuV)	Lim(dBuV)	Δ (lev-Lim)
	0.045	84.2	0.0	84.2
	22.725	49.8	50.0	-0.2

Copyright © 2011 Integrated Silicon Solution, Inc. All rights reserved. ISSI reserves the right to make changes to this specification and its products at any time without notice. ISSI assumes no liability arising out of the application or use of any information, products or services described herein. Customers are advised to obtain the latest version of this device specification before relying on any published information and before placing orders for products.

Integrated Silicon Solution, Inc. does not recommend the use of any of its products in life support applications where the failure or malfunction of the product can reasonably be expected to cause failure of the life support system or to significantly affect its safety or effectiveness. Products are not authorized for use in such applications unless Integrated Silicon Solution, Inc. receives written assurance to its satisfaction, that:

- a.) the risk of injury or damage has been minimized;
- b.) the user assume all such risks; and
- c.) potential liability of Integrated Silicon Solution, Inc is adequately protected under the circumstance