



Chipsmall Limited consists of a professional team with an average of over 10 year of expertise in the distribution of electronic components. Based in Hongkong, we have already established firm and mutual-benefit business relationships with customers from,Europe,America and south Asia,supplying obsolete and hard-to-find components to meet their specific needs.

With the principle of “Quality Parts,Customers Priority,Honest Operation,and Considerate Service”,our business mainly focus on the distribution of electronic components. Line cards we deal with include Microchip,ALPS,ROHM,Xilinx,Pulse,ON,Everlight and Freescale. Main products comprise IC,Modules,Potentiometer,IC Socket,Relay,Connector.Our parts cover such applications as commercial,industrial, and automotives areas.

We are looking forward to setting up business relationship with you and hope to provide you with the best service and solution. Let us make a better world for our industry!



Contact us

Tel: +86-755-8981 8866 Fax: +86-755-8427 6832

Email & Skype: info@chipsmall.com Web: www.chipsmall.com

Address: A1208, Overseas Decoration Building, #122 Zhenhua RD., Futian, Shenzhen, China



IS62WV1288ALL IS62WV1288BLL, IS65WV1288BLL



DECEMBER 2008

128K x 8 LOW VOLTAGE, ULTRA LOW POWER CMOS STATIC RAM

FEATURES

- High-speed access time: 45ns, 55ns, 70ns
- CMOS low power operation:
 - 30 mW (typical) operating
 - 15 μ W (typical) CMOS standby
- TTL compatible interface levels
- Single power supply:
 - 1.65V--2.2V V_{DD} (62WV1288ALL)
 - 2.5V--3.6V V_{DD} (62WV1288BLL/ 65WV1288BLL)
- Fully static operation: no clock or refresh required
- Three state outputs
- Automotive and Industrial temperatures available
- Lead-free available

DESCRIPTION

The *ISSI* IS62WV1288ALL / IS62/65WV1288BLL are high-speed, 1M bit static RAMs organized as 128K words by 8 bits. It is fabricated using *ISSI*'s high-performance CMOS technology. This highly reliable process coupled with innovative circuit design techniques, yields high-performance and low power consumption devices.

When $\overline{CS1}$ is HIGH (deselected) or when CS2 is LOW (deselected), the device assumes a standby mode at which the power dissipation can be reduced down with CMOS input levels.

Easy memory expansion is provided by using Chip Enable and Output Enable inputs. The active LOW Write Enable (\overline{WE}) controls both writing and reading of the memory.

The IS62WV1288ALL and IS62/65WV1288BLL are packaged in the JEDEC standard 32-pin TSOP (TYPEI), sTSOP (TYPEI), SOP, and 36-pin mini BGA.

FUNCTIONAL BLOCK DIAGRAM

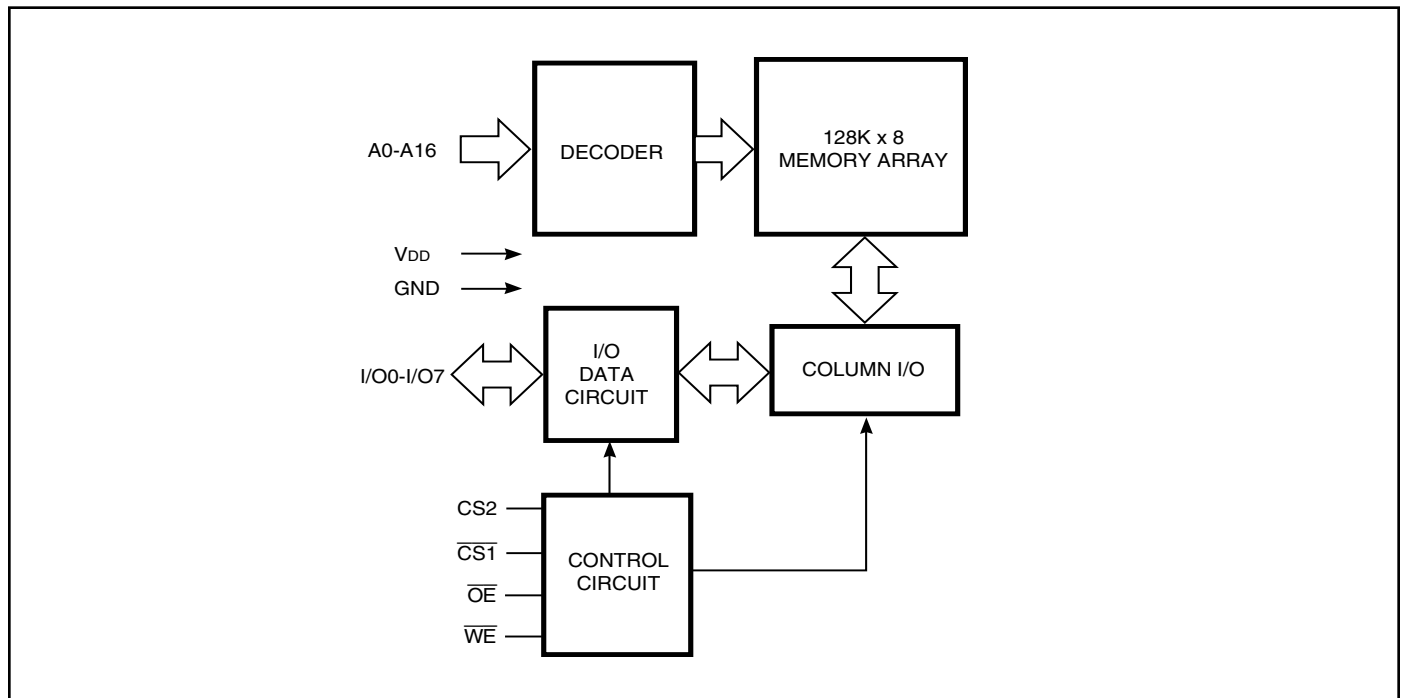

Copyright © 2005 Integrated Silicon Solution, Inc. All rights reserved. ISSI reserves the right to make changes to this specification and its products at any time without notice. ISSI assumes no liability arising out of the application or use of any information, products or services described herein. Customers are advised to obtain the latest version of this device specification before relying on any published information and before placing orders for products.

PIN CONFIGURATION

36-pin mini BGA (B) (6mm x 8mm)

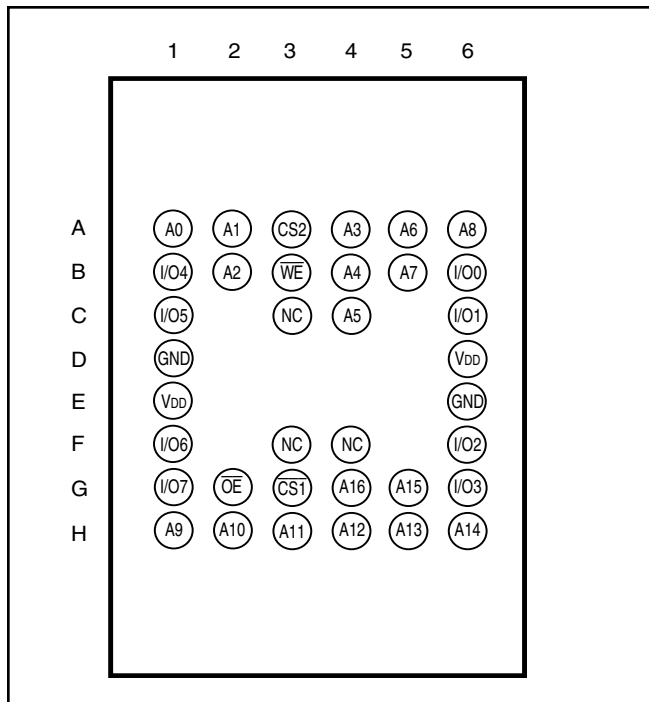

**32-pin TSOP (TYPE I) (T),
32-pin sTSOP (TYPE I) (H)**

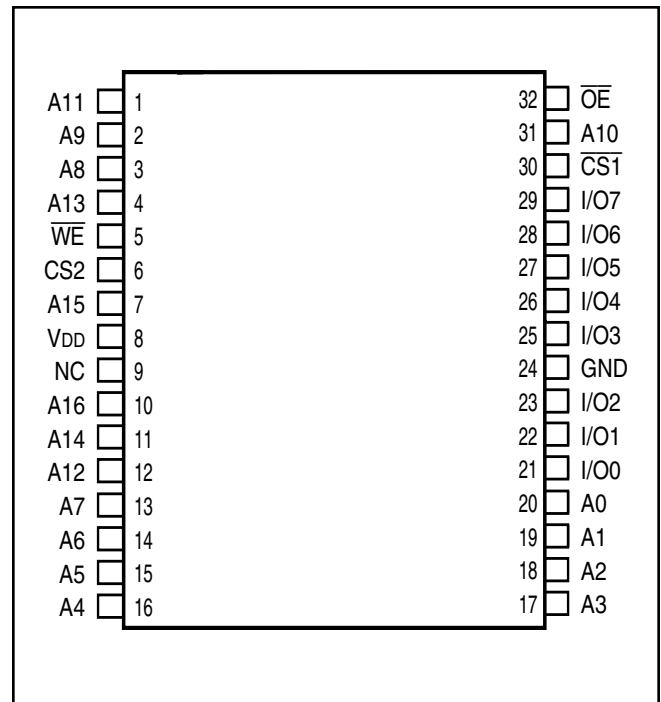

PIN DESCRIPTIONS

A0-A16	Address Inputs
CS1	Chip Enable 1 Input
CS2	Chip Enable 2 Input
OE	Output Enable Input
WE	Write Enable Input
I/O0-I/O7	Input/Output
NC	No Connection
VDD	Power
GND	Ground

32-pin SOP (Q)

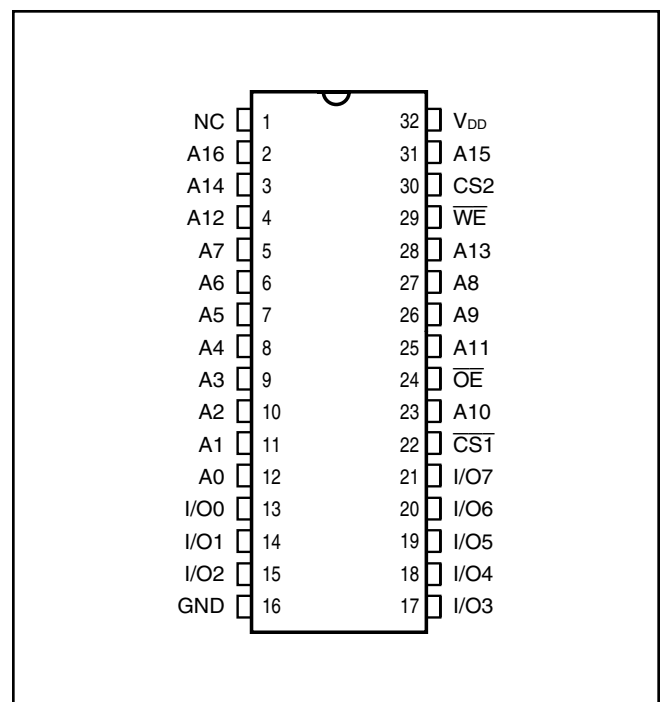

ABSOLUTE MAXIMUM RATINGS⁽¹⁾

Symbol	Parameter	Value	Unit
V _{TERM}	Terminal Voltage with Respect to GND	-0.2 to V _{DD} +0.3	V
V _{DD}	V _{DD} Related to GND	-0.2 to +3.8	V
T _{STG}	Storage Temperature	-65 to +150	°C
P _T	Power Dissipation	1.0	W

Note:

1. Stress greater than those listed under ABSOLUTE MAXIMUM RATINGS may cause permanent damage to the device. This is a stress rating only and functional operation of the device at these or any other conditions above those indicated in the operational sections of this specification is not implied. Exposure to absolute maximum rating conditions for extended periods may affect reliability.

OPERATING RANGE (V_{DD})

Range	Ambient Temperature	IS62WV1288ALL	IS62/65WV1288BLL
Commercial	0°C to +70°C	1.65V - 2.2V	2.5V - 3.6V
Industrial/A1	-40°C to +85°C	1.65V - 2.2V	2.5V - 3.6V
Automotive	-40°C to +125°C		2.5V - 3.6V

DC ELECTRICAL CHARACTERISTICS (Over Operating Range)

Symbol	Parameter	Test Conditions	V _{DD}	Min.	Max.	Unit
V _{OH}	Output HIGH Voltage	I _{OH} = -0.1 mA	1.65-2.2V	1.4	—	V
		I _{OH} = -1 mA	2.5-3.6V	2.2	—	V
V _{OL}	Output LOW Voltage	I _{OL} = 0.1 mA	1.65-2.2V	—	0.2	V
		I _{OL} = 2.1 mA	2.5-3.6V	—	0.4	V
V _{IH} ⁽²⁾	Input HIGH Voltage		1.65-2.2V	1.4	V _{DD} + 0.2	V
			2.5-3.6V	2.2	V _{DD} + 0.3	V
V _{IL} ⁽¹⁾	Input LOW Voltage		1.65-2.2V	-0.2	0.4	V
			2.5-3.6V	-0.2	0.6	V
I _{LI}	Input Leakage	GND ≤ V _{IN} ≤ V _{DD}		-1	1	μA
I _{LO}	Output Leakage	GND ≤ V _{OUT} ≤ V _{DD} , Outputs Disabled		-1	1	μA

Notes:

1. Undershoot: -1.0V for pulse width less than 10 ns. Not 100% tested.
2. Overshoot: V_{DD} + 1.0V for pulse width less than 10 ns. Not 100% tested.

TRUTH TABLE

Mode	\overline{WE}	$\overline{CS1}$	CS2	\overline{OE}	I/O Operation	V _{DD} Current
Not Selected	X	H	X	X	High-Z	I _{SB1} , I _{SB2}
(Power-down)	X	X	L	X	High-Z	I _{SB1} , I _{SB2}
Output Disabled	H	L	H	H	High-Z	I _{CC}
Read	H	L	H	L	D _{OUT}	I _{CC}
Write	L	L	H	X	D _{IN}	I _{CC}

CAPACITANCE⁽¹⁾

Symbol	Parameter	Conditions	Max.	Unit
C _{IN}	Input Capacitance	V _{IN} = 0V	8	pF
C _{OUT}	Input/Output Capacitance	V _{OUT} = 0V	10	pF

Note:

1. Tested initially and after any design or process changes that may affect these parameters.

AC TEST CONDITIONS

Parameter	62WV1288ALL	62/65WV1288BLL
	(Unit)	(Unit)
Input Pulse Level	0.4V to V _{DD} -0.2V	0.4V to V _{DD} -0.3V
Input Rise and Fall Times	5 ns	5ns
Input and Output Timing and Reference Level	V _{REF}	V _{REF}
Output Load	See Figures 1 and 2	See Figures 1 and 2

	1.65V - 2.2V	2.5V - 3.6V
R1(Ω)	3070	3070
R2(Ω)	3150	3150
V _{REF}	0.9V	1.5V
V _{TM}	1.8V	2.8V

AC TEST LOADS

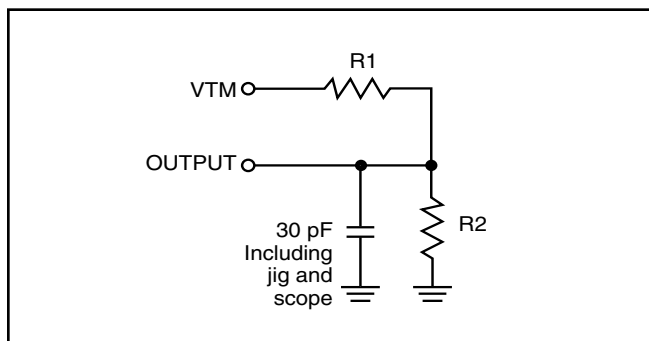

Figure 1

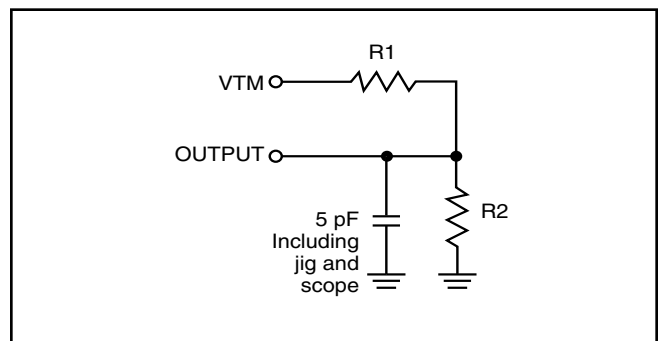

Figure 2

IS62WV1288ALL, IS62WV1288BLL, IS65WV1288BLL

POWER SUPPLY CHARACTERISTICS⁽¹⁾ (Over Operating Range)

1.65V - 2.2V

Symbol	Parameter	Test Conditions		Max. 70 ns	Unit
I _{CC}	V _{DD} Dynamic Operating Supply Current	V _{DD} = Max., I _{OUT} = 0 mA, f = f _{MAX}	Com.	8	mA
			Ind.	8	
			typ. ⁽²⁾	5	
I _{CC1}	Operating Supply Current	V _{DD} = Max., I _{OUT} = 0 mA, f = 0	Com. Ind.	5 5	mA
I _{SB1}	TTL Standby Current (TTL Inputs)	V _{DD} = Max., V _{IN} = V _{IH} or V _{IL} CS ₁ = V _{IH} , CS ₂ = V _{IL} , f = 1 MHz	Com.	0.8	mA
			Ind.	0.8	
I _{SB2}	CMOS Standby Current (CMOS Inputs)	V _{DD} = Max., CS ₁ ≥ V _{DD} - 0.2V, CS ₂ ≤ 0.2V, V _{IN} ≥ V _{DD} - 0.2V, or V _{IN} ≤ 0.2V, f = 0	Com.	10	μA
			Ind.	10	
			typ. ⁽²⁾	5	

Note:

- At f = f_{MAX}, address and data inputs are cycling at the maximum frequency, f = 0 means no input lines change.
- Typical values are measured at V_{DD}=1.8V, T_A=25°C. Not 100% tested.

POWER SUPPLY CHARACTERISTICS⁽¹⁾ (Over Operating Range)

2.5V - 3.6V

Symbol	Parameter	Test Conditions		Max. 45ns	Max. 55 ns	Unit
I _{CC}	V _{DD} Dynamic Operating Supply Current	V _{DD} = Max., I _{OUT} = 0 mA, f = f _{MAX}	Com.	17	15	mA
			Ind./A1	17	15	
			A3 typ. ⁽²⁾	12	10	
I _{CC1}	Operating Supply Current	V _{DD} = Max., I _{OUT} = 0 mA, f = 0	Com.	5	5	mA
			Ind./A1	5	5	
			A3		7	
I _{SB1}	TTL Standby Current (TTL Inputs)	V _{DD} = Max., V _{IN} = V _{IH} or V _{IL} CS ₁ = V _{IH} , CS ₂ = V _{IL} , f = 1 MHz	Com.	0.8	0.8	mA
			Ind./A1	0.8	0.8	
			A3		3	
I _{SB2}	CMOS Standby Current (CMOS Inputs)	V _{DD} = Max., CS ₁ ≥ V _{DD} - 0.2V, CS ₂ ≤ 0.2V, V _{IN} ≥ V _{DD} - 0.2V, or V _{IN} ≤ 0.2V, f = 0	Com.	10	10	μA
			Ind./A1	10	10	
			A3		75	
			typ. ⁽²⁾	5	5	

Note:

- At f = f_{MAX}, address and data inputs are cycling at the maximum frequency, f = 0 means no input lines change.
- Typical values are measured at V_{DD}=3.0V, T_A=25°C. Not 100% tested.

READ CYCLE SWITCHING CHARACTERISTICS⁽¹⁾ (Over Operating Range)

Symbol	Parameter	45 ns		55 ns		70 ns		Unit
		Min.	Max.	Min.	Max.	Min.	Max.	
t _{RC}	Read Cycle Time	45	—	55	—	70	—	ns
t _{AA}	Address Access Time	—	45	—	55	—	70	ns
t _{OHA}	Output Hold Time	10	—	10	—	10	—	ns
t _{ACS1} /t _{ACS2}	CS1/CS2 Access Time	—	45	—	55	—	70	ns
t _{DOE}	OE Access Time	—	20	—	25	—	35	ns
t _{HZOE} ⁽²⁾	OE to High-Z Output	0	15	0	20	0	25	ns
t _{LZOE} ⁽²⁾	OE to Low-Z Output	5	—	5	—	5	—	ns
t _{HZCS1} /t _{HZCS2} ⁽²⁾	CS1/CS2 to High-Z Output	0	15	0	20	0	25	ns
t _{LZCS1} /t _{LZCS2} ⁽²⁾	CS1/CS2 to Low-Z Output	5	—	10	—	10	—	ns

Notes:

1. Test conditions assume signal transition times of 5 ns or less, timing reference levels of 0.9V/1.5V, input pulse levels of 0.4 to V_{DD}-0.2V/V_{DD}-0.3V and output loading specified in Figure 1.
2. Tested with the load in Figure 2. Transition is measured ±500 mV from steady-state voltage. Not 100% tested.

AC WAVEFORMS

READ CYCLE NO. 1^(1,2) (Address Controlled) ($\overline{CS1} = \overline{OE} = V_{IL}$, $CS2 = \overline{WE} = V_{IH}$)

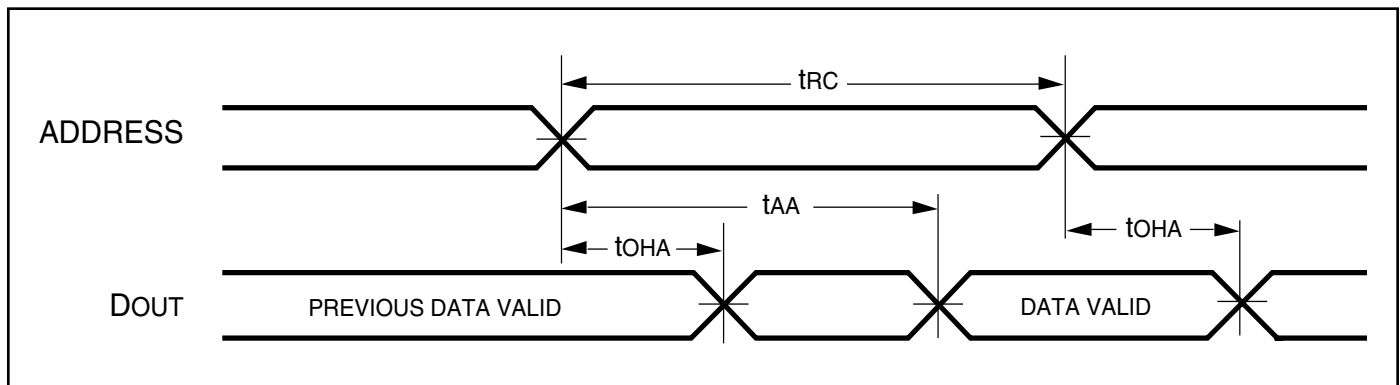

AC WAVEFORMS

READ CYCLE NO. 2^(1,3) ($\overline{CS1}$, CS2, \overline{OE} Controlled)

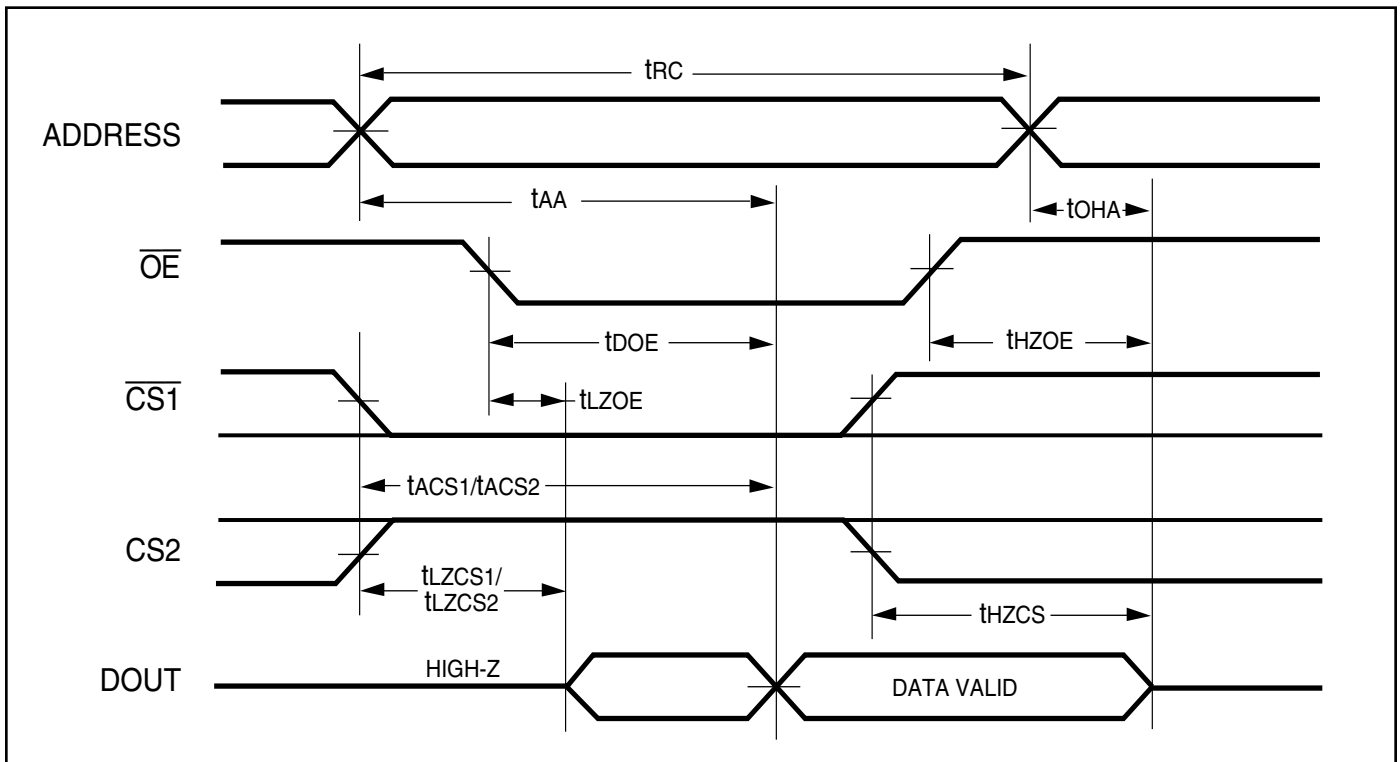

Notes:

1. \overline{WE} is HIGH for a Read Cycle.
2. The device is continuously selected. \overline{OE} , $\overline{CS1} = V_{IL}$. $CS2 = \overline{WE} = V_{IH}$.
3. Address is valid prior to or coincident with $\overline{CS1}$ LOW and CS2 HIGH transition.

WRITE CYCLE SWITCHING CHARACTERISTICS^(1,2) (Over Operating Range)

Symbol	Parameter	45 ns		55 ns		70 ns		Unit
		Min.	Max.	Min.	Max.	Min.	Max.	
t _{wc}	Write Cycle Time	45	—	55	—	70	—	ns
t _{sCS1/tCS2}	CS1/CS2 to Write End	35	—	45	—	60	—	ns
t _{AW}	Address Setup Time to Write End	35	—	45	—	60	—	ns
t _{HA}	Address Hold from Write End	0	—	0	—	0	—	ns
t _{SA}	Address Setup Time	0	—	0	—	0	—	ns
t _{PWE}	WE Pulse Width	35	—	40	—	50	—	ns
t _{SD}	Data Setup to Write End	20	—	25	—	30	—	ns
t _{HD}	Data Hold from Write End	0	—	0	—	0	—	ns
t _{HZWE⁽³⁾}	WE LOW to High-Z Output	—	20	—	20	—	20	ns
t _{LZWE⁽³⁾}	WE HIGH to Low-Z Output	5	—	5	—	5	—	ns

Notes:

1. Test conditions assume signal transition times of 5 ns or less, timing reference levels of 0.9V/1.5V, input pulse levels of 0.4V to V_{DD}-0.2V/V_{DD}-0.3V and output loading specified in Figure 1.
2. The internal write time is defined by the overlap of $\overline{CS1}$ LOW, CS2 HIGH, and \overline{WE} LOW. All signals must be in valid states to initiate a Write, but any one can go inactive to terminate the Write. The Data Input Setup and Hold timing are referenced to the rising or falling edge of the signal that terminates the write.
3. Tested with the load in Figure 2. Transition is measured ± 500 mV from steady-state voltage. Not 100% tested.

AC WAVEFORMS

WRITE CYCLE NO. 1 ($\overline{CS1}$ /CS2 Controlled, \overline{OE} = HIGH or LOW)

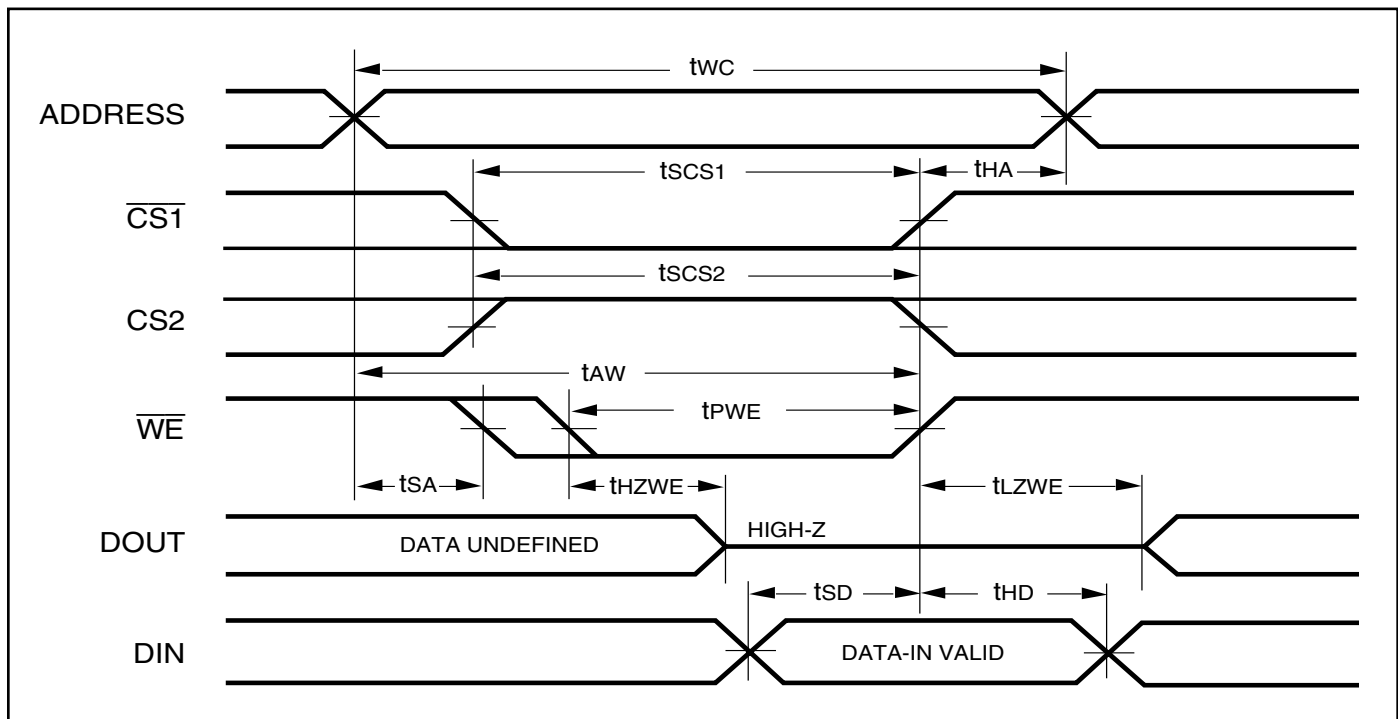

AC WAVEFORMS

WRITE CYCLE NO. 2 (\overline{WE} Controlled: \overline{OE} is HIGH During Write Cycle)

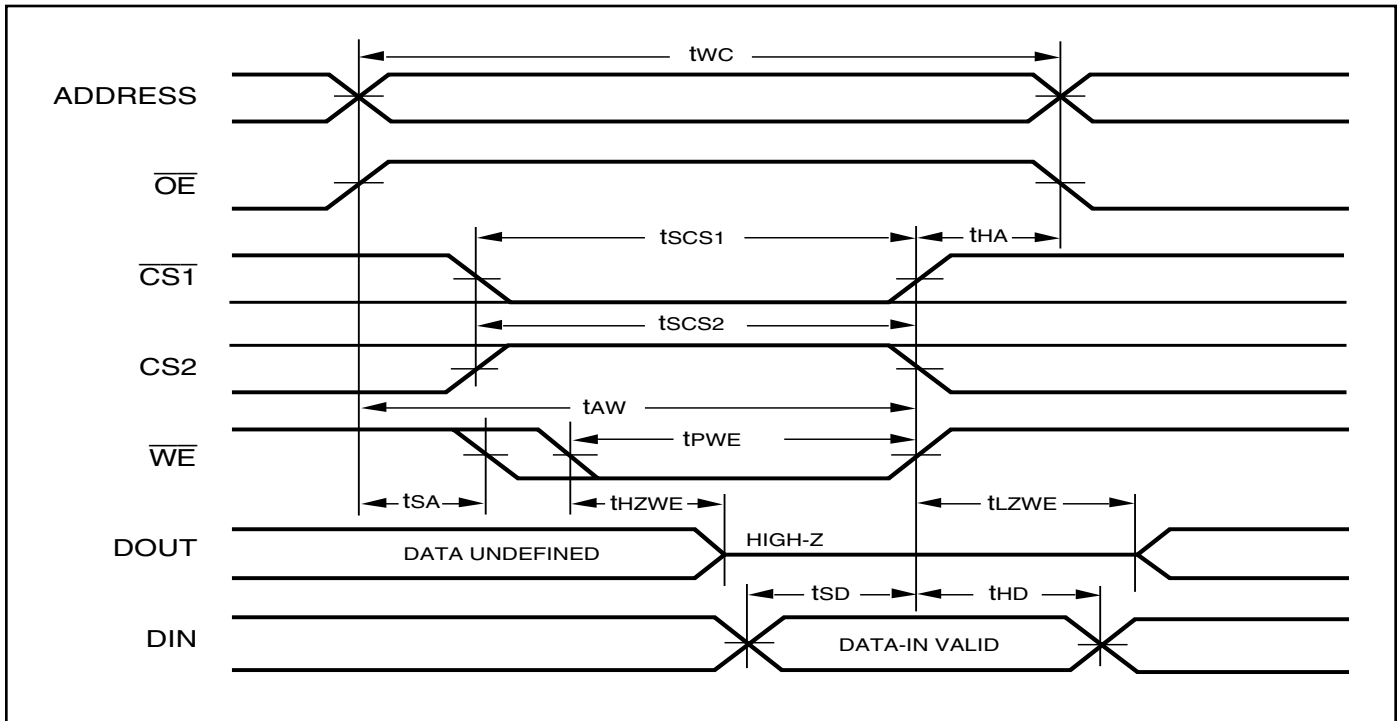

WRITE CYCLE NO. 3 (\overline{WE} Controlled: \overline{OE} is LOW During Write Cycle)

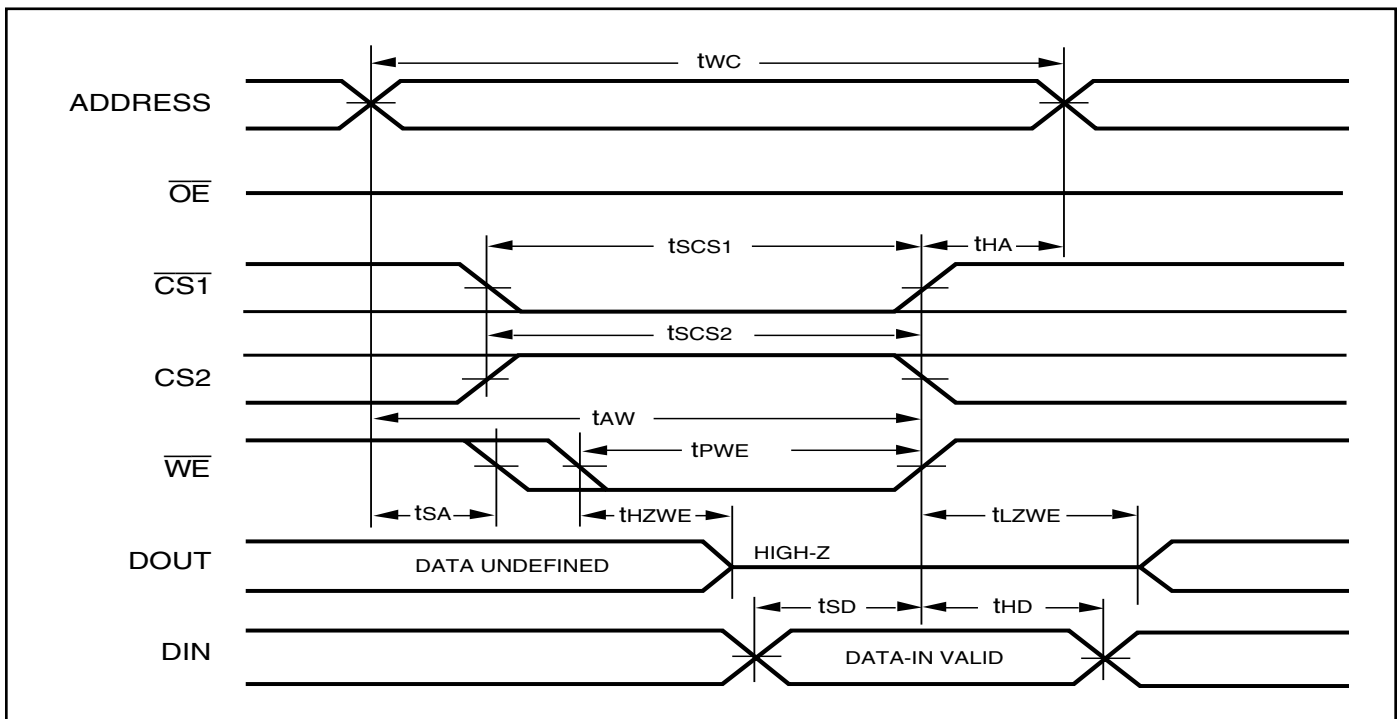

DATA RETENTION SWITCHING CHARACTERISTICS

Symbol	Parameter	Test Condition	Min.	Max.	Unit
V_{DR}	V_{DD} for Data Retention	See Data Retention Waveform	1.2	3.6	V
I_{DR}	Data Retention Current	$V_{DD} = 1.2V, \overline{CS1} \geq V_{DD} - 0.2V$	Com. Ind./A1 A3	— 5 10 75	μA
t_{SDR}	Data Retention Setup Time	See Data Retention Waveform	0	—	ns
t_{RDR}	Recovery Time	See Data Retention Waveform	t_{RC}	—	ns

DATA RETENTION WAVEFORM ($\overline{CS1}$ Controlled)

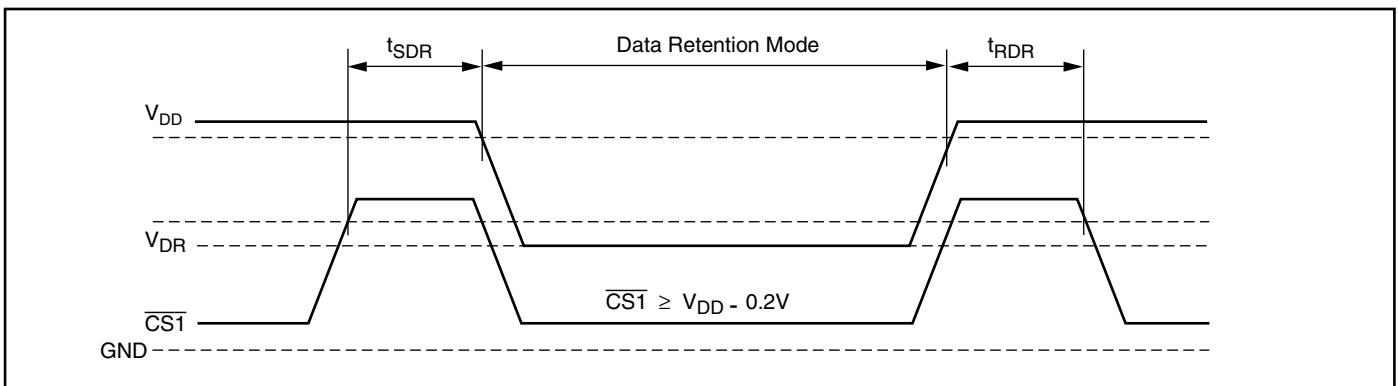

DATA RETENTION WAVEFORM (CS2 Controlled)

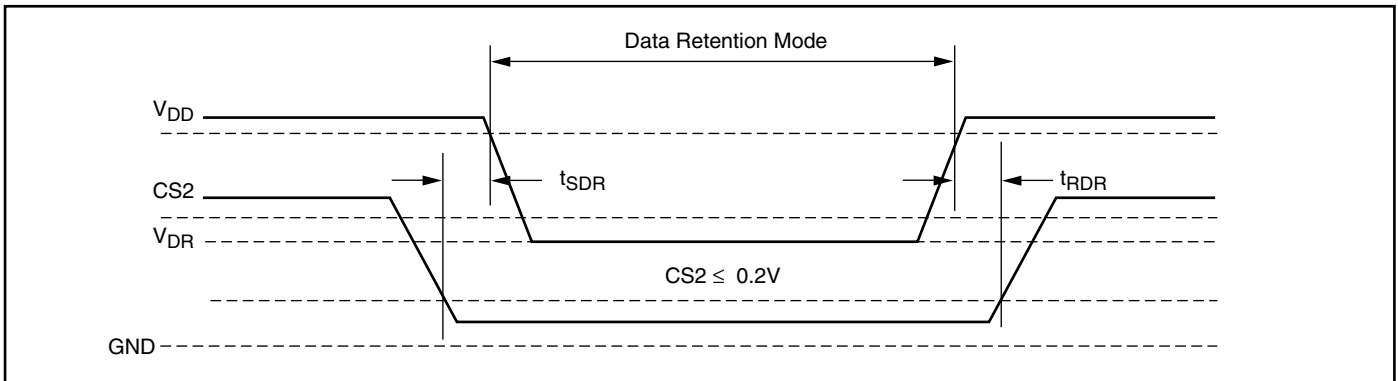

ORDERING INFORMATION
IS62WV1288ALL (1.65V - 2.2V)
Industrial Range: -40°C to +85°C

Speed (ns)	Order Part No.	Package
70	IS62WV1288ALL-70BI	mini BGA (6mm x 8mm)
	IS62WV1288ALL-70HI	sTSOP, TYPE I

IS62WV1288BLL (2.5V-3.6V)
Industrial Range: -40°C to +85°C

Speed (ns)	Order Part No.	Package
45	IS62WV1288BLL-45TI	TSOP, TYPE I
	IS62WV1288BLL-45BI	mini BGA (6mm x 8mm)
	IS62WV1288BLL-45HI	sTSOP, TYPE I
	IS62WV1288BLL-45HLI	sTSOP, TYPE I, Lead-free
	IS62WV1288BLL-45QI	SOP
55	IS62WV1288BLL-55TI	TSOP, TYPE I
	IS62WV1288BLL-55TLI	TSOP, TYPE I, Lead-free
	IS62WV1288BLL-55BI	mini BGA (6mm x 8mm)
	IS62WV1288BLL-55HI	sTSOP, TYPE I
	IS62WV1288BLL-55HLI	sTSOP, TYPE I, Lead-free
	IS62WV1288BLL-55QI	SOP
	IS62WV1288BLL-55QLI	SOP, Lead-free

IS65WV1288BLL (2.5V-3.6V)
A1 Range: -40°C to +85°C

Speed (ns)	Order Part No.	Package
55	IS65WV1288BLL-55HLA1	sTSOP, TYPE I, Lead-free
	IS65WV1288BLL-55TLA1	TSOP, TYPE I, Lead-free

A3 Range: -40°C to +125°C

Speed (ns)	Order Part No.	Package
55	IS65WV1288BLL-55HLA3	sTSOP, TYPE I, Lead-free

PACKAGING INFORMATION

450-mil Plastic SOP
 Package Code: Q (32-pin)

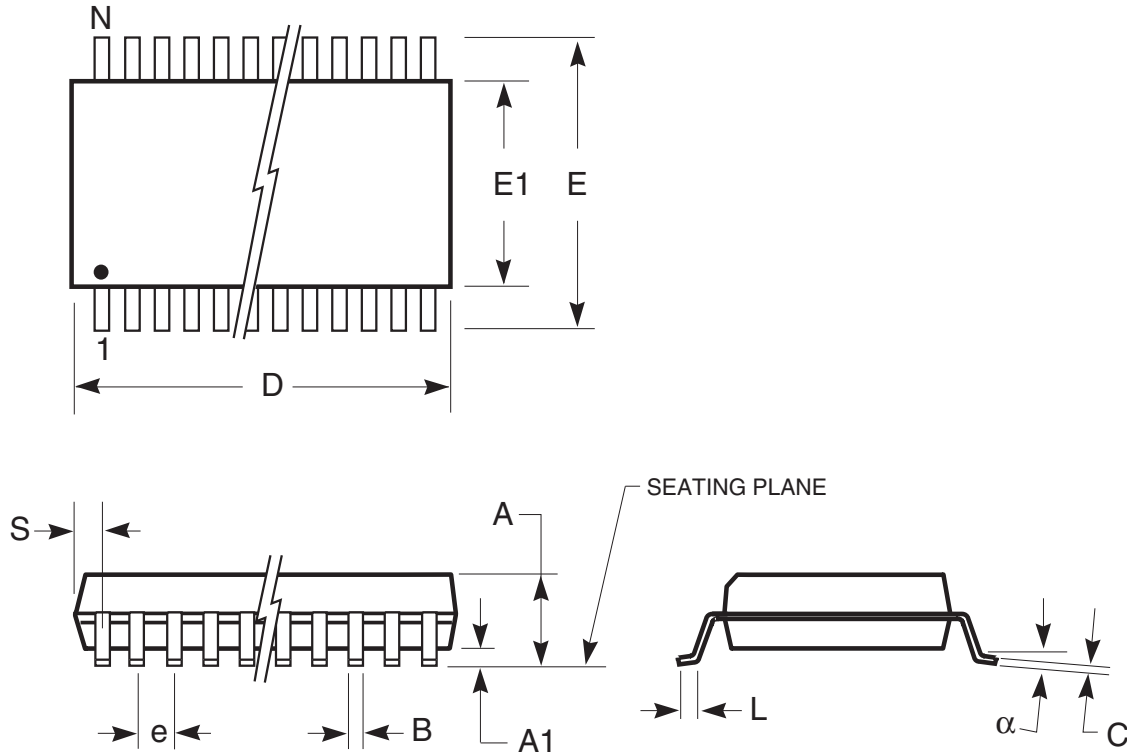

	MILLIMETERS		INCHES	
Symbol	Min.	Max.	Min.	Max.
No. Leads	32			
A	—	3.00	—	0.118
A1	0.10	—	0.004	—
B	0.36	0.51	0.014	0.020
C	0.15	0.30	0.006	0.012
D	20.14	20.75	0.793	0.817
E	13.87	14.38	0.546	0.566
E1	11.18	11.43	0.440	0.450
e	1.27 BSC		0.050 BSC	
L	0.58	0.99	0.023	0.039
α	0°	10°	0°	10°
S	—	0.86	—	0.034

Notes:

1. Controlling dimension: inches, unless otherwise specified.
2. BSC = Basic lead spacing between centers.
3. Dimensions D and E1 do not include mold flash protrusions and should be measured from the bottom of the package.
4. Formed leads shall be planar with respect to one another within 0.004 inches at the seating plane.

PACKAGING INFORMATION

Plastic STSOP - 32 pins

Package Code: H (Type I)

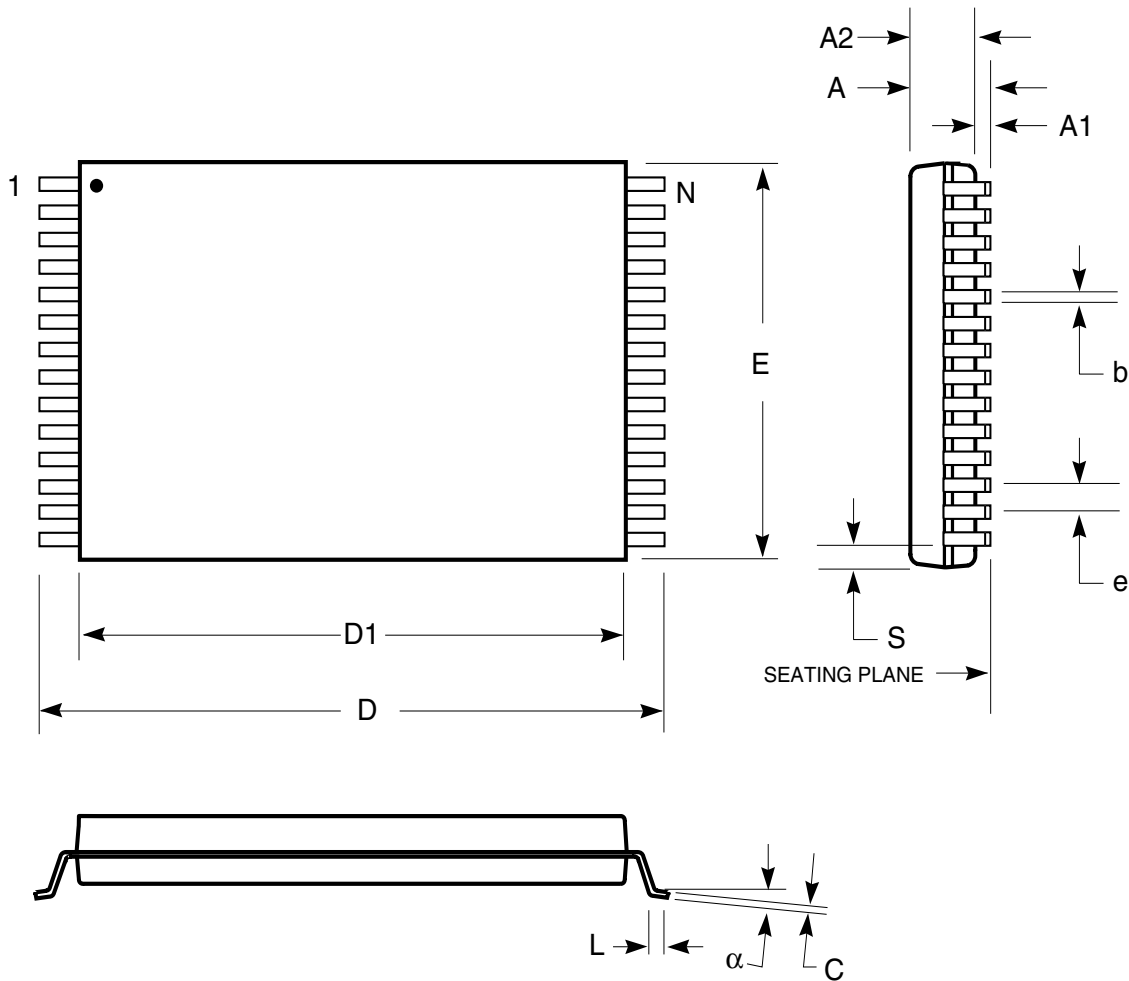

Plastic STSOP (H - Type I)				
	Millimeters		Inches	
Symbol	Min	Max	Min	Max
Ref. Std.				
N	32			
A	—	1.25	—	0.049
A1	0.05	—	0.002	—
A2	0.95	1.05	0.037	0.041
b	0.17	0.23	0.007	0.009
C	0.14	0.16	0.0055	0.0063
D	13.20	13.60	0.520	0.535
D1	11.70	11.90	0.461	0.469
E	7.90	8.10	0.311	0.319
e	0.50 BSC		0.020 BSC	
L	0.30	0.70	0.012	0.028
S	0.28 Typ.		0.011 Typ.	
α	0°	5°	0°	5°

Notes:

1. Controlling dimension: millimeters, unless otherwise specified.
2. BSC = Basic lead spacing between centers.
3. Dimensions D1 and E do not include mold flash protrusions and should be measured from the bottom of the package.
4. Formed leads shall be planar with respect to one another within 0.004 inches at the seating plane.

PACKAGING INFORMATION

Mini Ball Grid Array Package Code: B (36-pin)

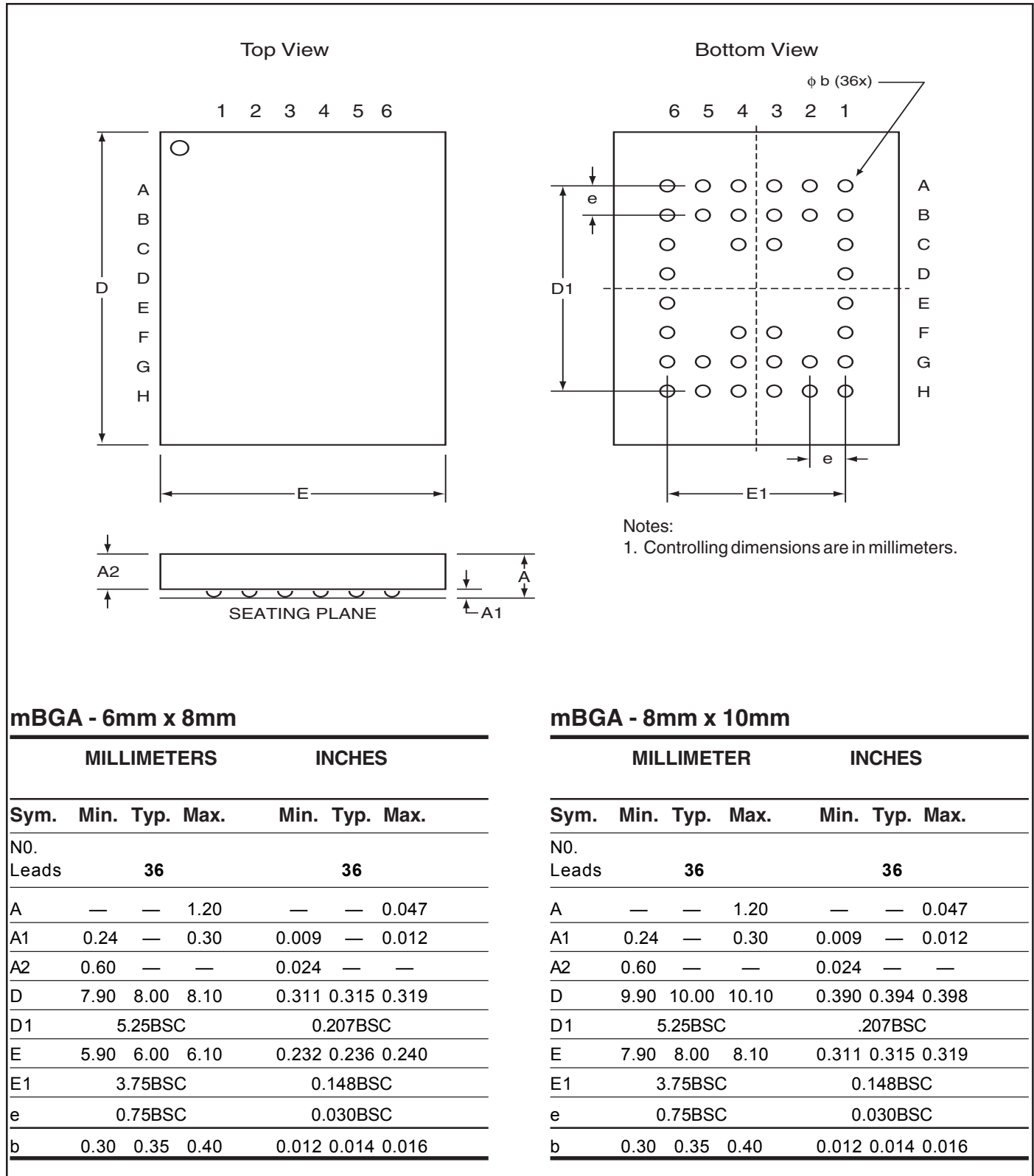

Copyright © 2003 Integrated Silicon Solution, Inc. All rights reserved. ISSI reserves the right to make changes to this specification and its products at any time without notice. ISSI assumes no liability arising out of the application or use of any information, products or services described herein. Customers are advised to obtain the latest version of this device specification before relying on any published information and before placing orders for products.

PACKAGING INFORMATION

Plastic TSOP-Type I

Package Code: T (32-pin)

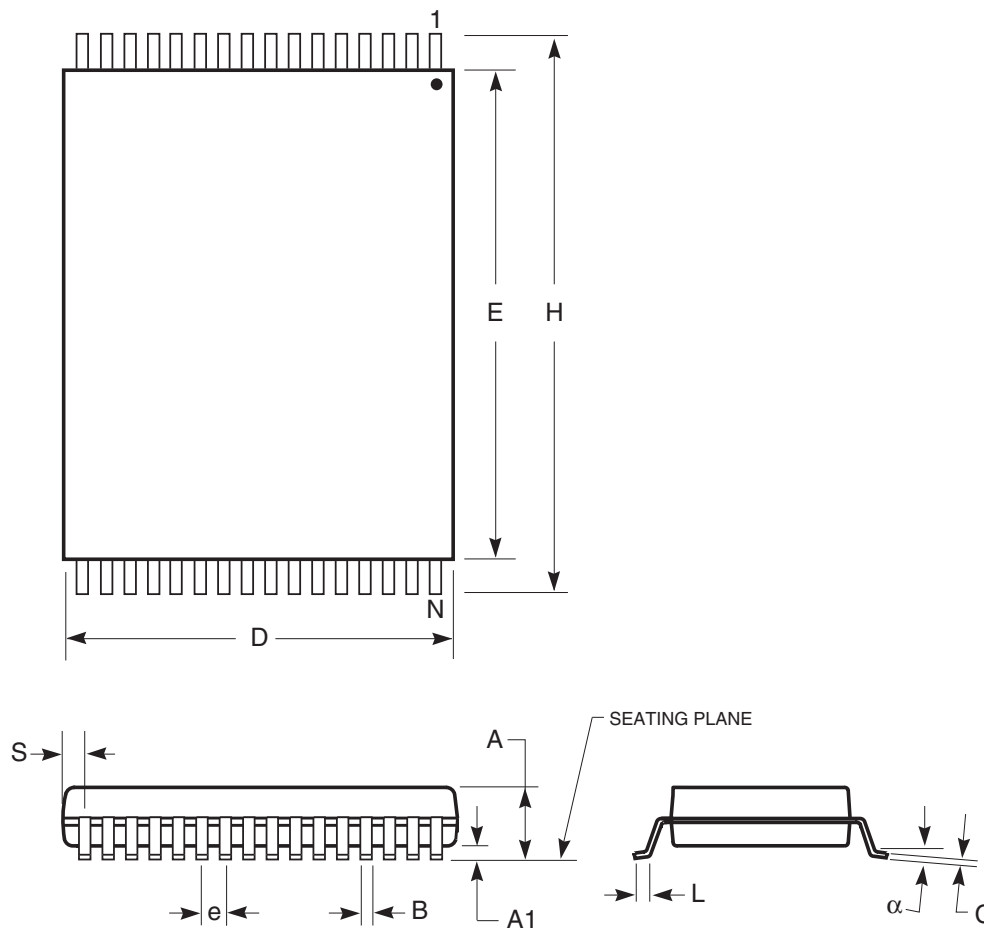

Symbol	MILLIMETERS		INCHES	
	Min.	Max.	Min.	Max.
No. Leads	32			
A	—	1.20	—	0.047
A1	0.05	0.25	0.002	0.010
B	0.17	0.23	0.007	0.009
C	0.12	0.17	0.005	0.007
D	7.90	8.10	0.311	0.319
E	18.30	18.50	0.720	0.728
H	19.80	20.20	0.780	0.795
e	0.50 BSC		0.020 BSC	
L	0.40	0.60	0.016	0.024
alpha	0°	8°	0°	8°
S	0.25 REF		0.010 REF	

Notes:

1. Controlling dimension: millimeters, unless otherwise specified.
2. BSC = Basic lead spacing between centers.
3. Dimensions D and E do not include mold flash protrusions and should be measured from the bottom of the package.
4. Formed leads shall be planar with respect to one another within 0.004 inches at the seating plane.