



Chipsmall Limited consists of a professional team with an average of over 10 year of expertise in the distribution of electronic components. Based in Hongkong, we have already established firm and mutual-benefit business relationships with customers from,Europe,America and south Asia,supplying obsolete and hard-to-find components to meet their specific needs.

With the principle of “Quality Parts,Customers Priority,Honest Operation,and Considerate Service”,our business mainly focus on the distribution of electronic components. Line cards we deal with include Microchip,ALPS,ROHM,Xilinx,Pulse,ON,Everlight and Freescale. Main products comprise IC,Modules,Potentiometer,IC Socket,Relay,Connector.Our parts cover such applications as commercial,industrial, and automotives areas.

We are looking forward to setting up business relationship with you and hope to provide you with the best service and solution. Let us make a better world for our industry!



Contact us

Tel: +86-755-8981 8866 Fax: +86-755-8427 6832

Email & Skype: info@chipsmall.com Web: www.chipsmall.com

Address: A1208, Overseas Decoration Building, #122 Zhenhua RD., Futian, Shenzhen, China



ISD-DEMO8101 User's Manual

The ISD-DEMO8101 is a SOP8 demo board for ISD8101 series. It is available to demonstrate basic functionality and to make it easy to try different configurations of components and component values.

In the standard configuration, there are no pins on any of the input/output pads on the PCB, and may be either soldered with wires or jumper pins. As a fast way to test, it is found that the larger size "E-Z Hook" style clip lead probe wires can attach easily to the holes around the outside edge of the PCB.

The picture below illustrates all the input controls and BTL speaker output.

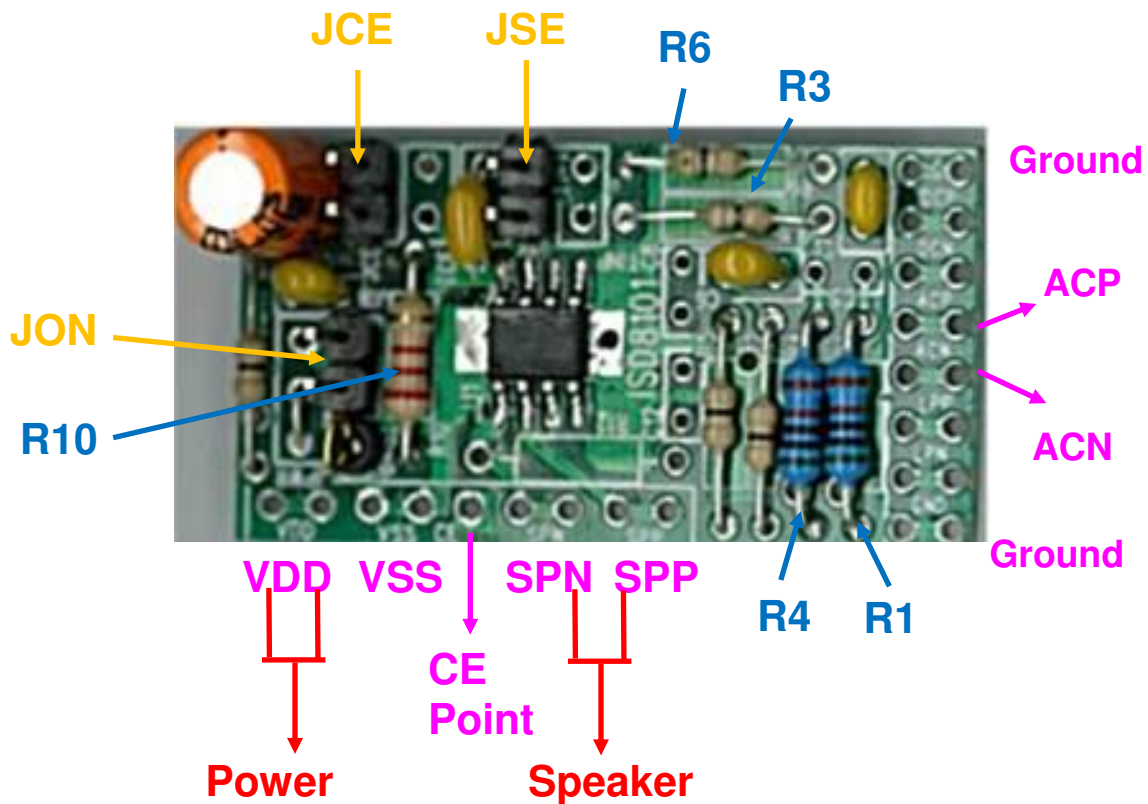

Figure 1: ISD-DEMO8101EV Pins and Jumpers Definition

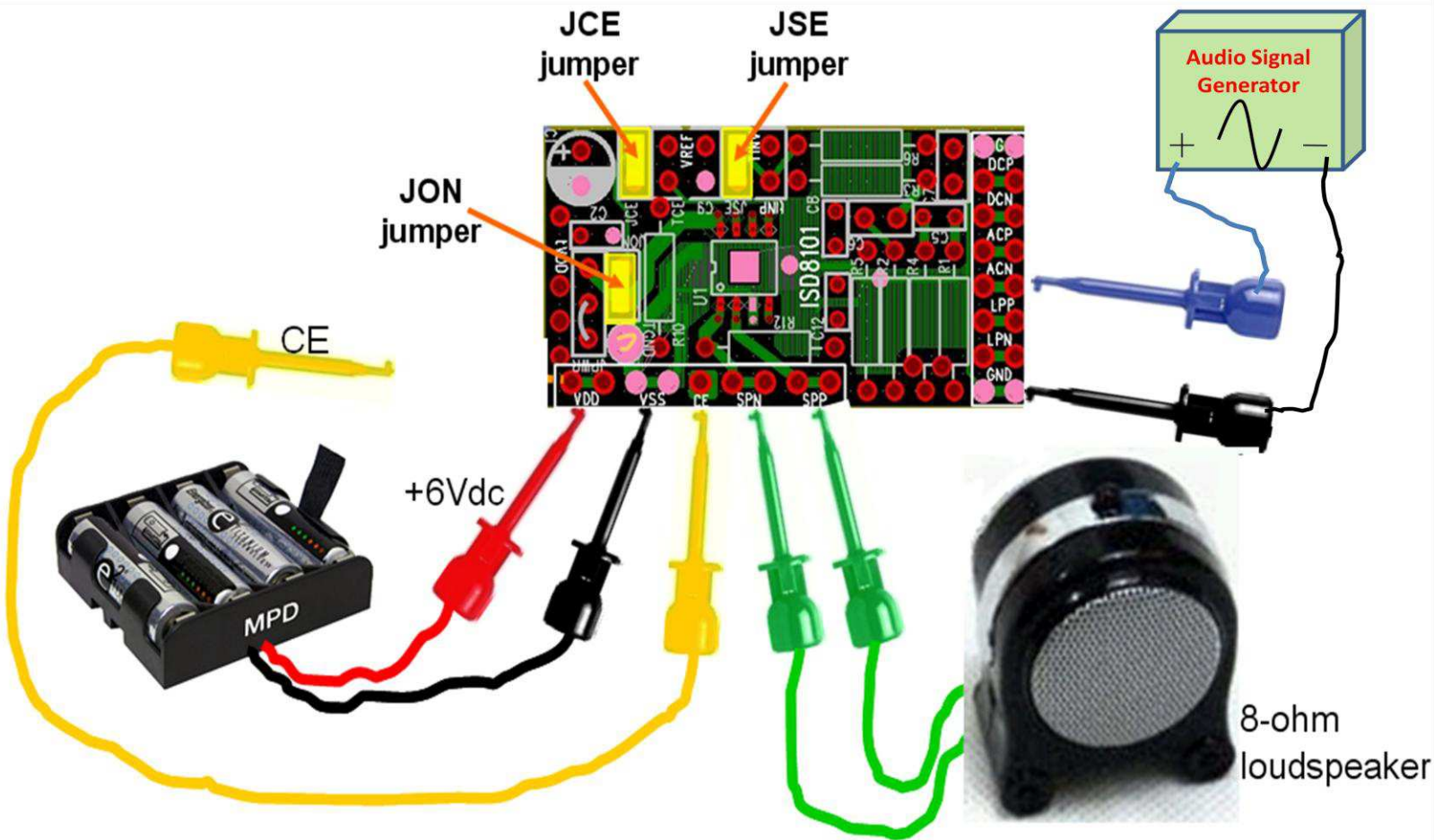

Figure 2: ISD-DEMO8101EVB Possible Connections

Hardware Connections:

- Connect an 8Ω or larger loading speaker to **SPP** and **SPN**.
- Connect a power supply to the related terminals. Please ensure the polarity of the power is correct to avoid any damages to the ISD8101 device.
- Connect **CE** either to VDD or Ground, and CE is active High
- Unity gain set of inputs: **LPN** and **LPP** are configured for low gain configurations. In the single ended use scenario, the signal may be applied only to the LPN input.
- A 20dB gain set of inputs: **ACN** and **ACP** are configured for high gain configurations. In the single ended use scenario, the signal should be applied only to the ACN input.
- Another set of high gain inputs, **DCN** and **DCP**, that have the same gain as for ACN and ACP, but that are DC coupled to the device input
- Jumper **JON**: install to cause the amplifier to be always "on" since CE is shorted to VDD.
- Jumper **JCE**: Connect the chip enable input to the CE connection point on the PCB. This is must be installed if an external CE control voltage will be used to control the device.
- Jumper **JSE**: Connect if the device is used in the "single ended" configuration.

Operations:Standalone Operations:

Below are four common ways that parts such as the ISD8101 are used in audio circuits. To use this user guide, it is best to first identify which of these configurations most closely matches the desired application scenario. Best performance is always achieved by using the differential configuration, and when this can be used, difficult noise/pop/click issues can be most reduced.

Figure 3: Single-Ended Design Controlled by Chip Enable. Lowest parts count using just one input, and an external controller manages the Chip Enable CE pin for best performance.

- i) Connect jumper JCE, and then CE depends on the CE point control voltage. Thus an external CE control voltage should be used to control the device.
- ii) Connect jumper JSE for single-ended input.
- iii) Connect power supply to VDD and ground to VSS.
- iv) Connect 8Ω (or larger) load speaker to SPP and SPN.
- v) Insert the input audio signal to either Unity Gain Input LPN (0dB gain configuration) or High Gain Input ACN (20dB gain configuration).

Figure 4: Single-Ended Design, Always-On Case (Chip Enable tied to Vdd). Lowest parts count using just one input, but no external controller is available to manage the Chip Enable CE pin. The device is always enabled by connection of the Chip Enable pin directly to Vdd.

- i) Connect jumper JON, and thus CE is always ON.
- ii) Connect jumper JSE for single-ended input.
- iii) Connect power supply to VDD and ground to VSS.
- iv) Connect 8Ω (or larger) load speaker to SPP and SPN.
- v) Insert the input audio signal to either Unity Gain Input LPN (0dB gain configuration) or High Gain Input ACN (20dB gain configuration).

Application Schematic:

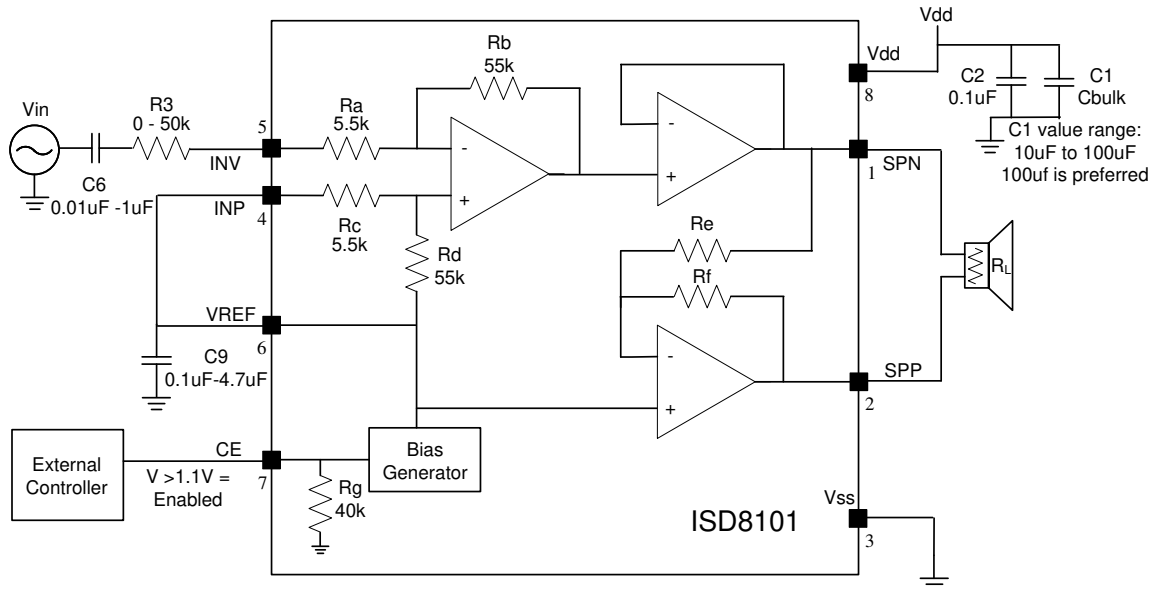

Figure 3: SINGLE-ENDED DESIGN CONTROLLED BY CHIP ENABLE CASE

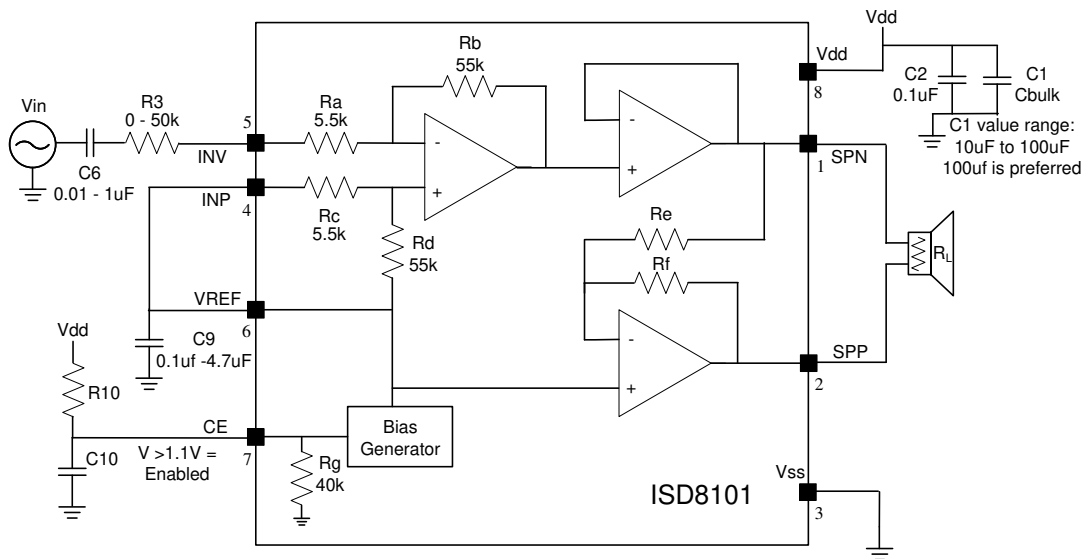

Figure 4: SINGLE-ENDED DESIGN, ALWAYS-ON CASE (CHIP ENABLE TIED TO Vdd)

Figure 5: Differential Input Design Controlled by Chip Enable. Differential inputs are used, and are best such as when filtering a PWM (Pulse Width Modulated) signal and handling other difficult signal input design requirements. An external controller manages Chip Enable.

- i) Connect jumper JCE, and then CE depends on the CE point control voltage. Thus an external CE control voltage should be used to control the device.
- ii) Connect power supply to VDD and ground to VSS.
- iii) Connect 8 Ω (or larger) load speaker to SPP and SPN.
- iv) Insert the input audio signal to either Unity Gain Differential Inputs **LPN** and **LPP** (0dB gain configuration) or High Gain Differential Inputs **ACN** and **ACP** (20dB gain configuration).

Figure 6: Differential Input Design, Always-On Case (Chip Enable tied to Vdd). Differential inputs are used, and are best such as when filtering a PWM (Pulse Width Modulated) signal and handling other difficult signal input design requirements. No external controller is available to manage the Chip Enable CE pin. The device is enabled at all times by connection of the Chip Enable CE pin directly to Vdd.

- i) Connect jumper JON, and thus CE is always ON.
- ii) Connect power supply to VDD and ground to VSS.
- iii) Connect 8 Ω (or larger) load speaker to SPP and SPN.
- iv) Insert the input audio signal to either Unity Gain Differential Inputs **LPN** and **LPP** (0dB gain configuration) or High Gain Differential Inputs **ACN** and **ACP** (20dB gain configuration).

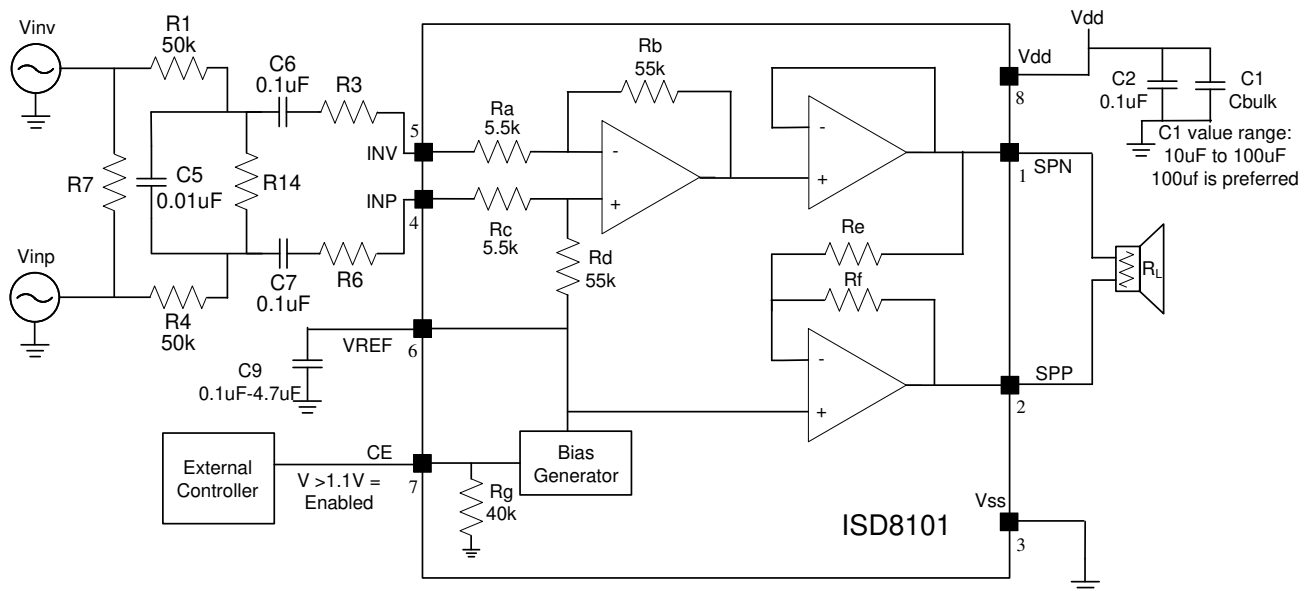

Figure 5: DIFFERENTIAL INPUT DESIGN CONTROLLED BY CHIP ENABLE CASE

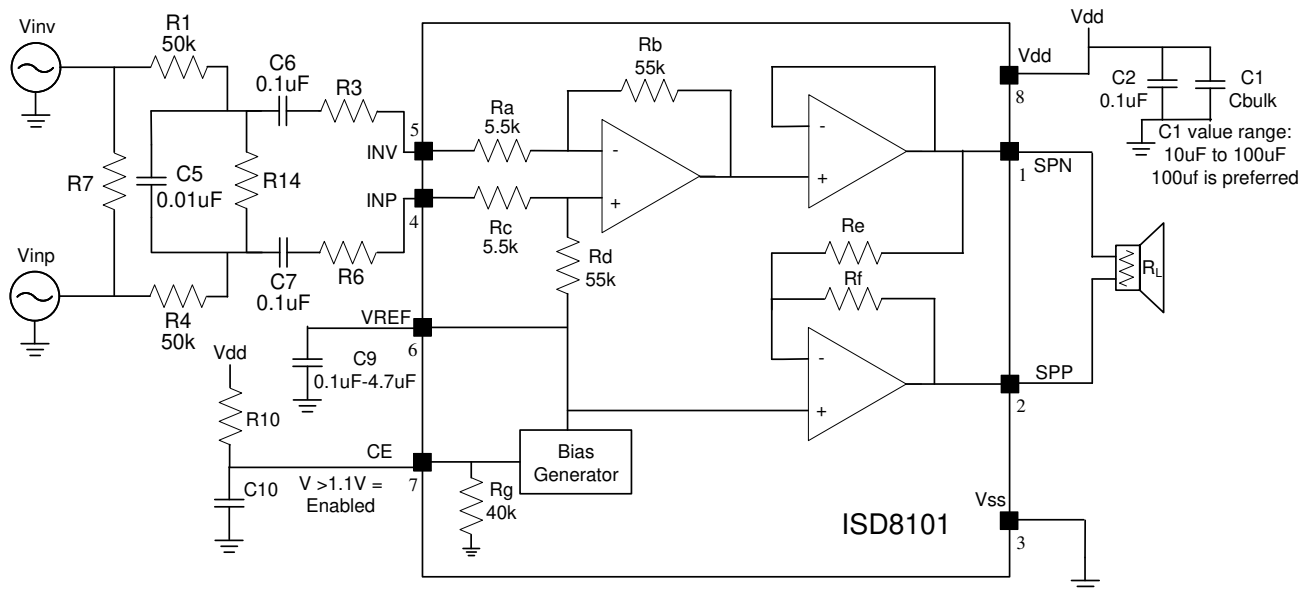
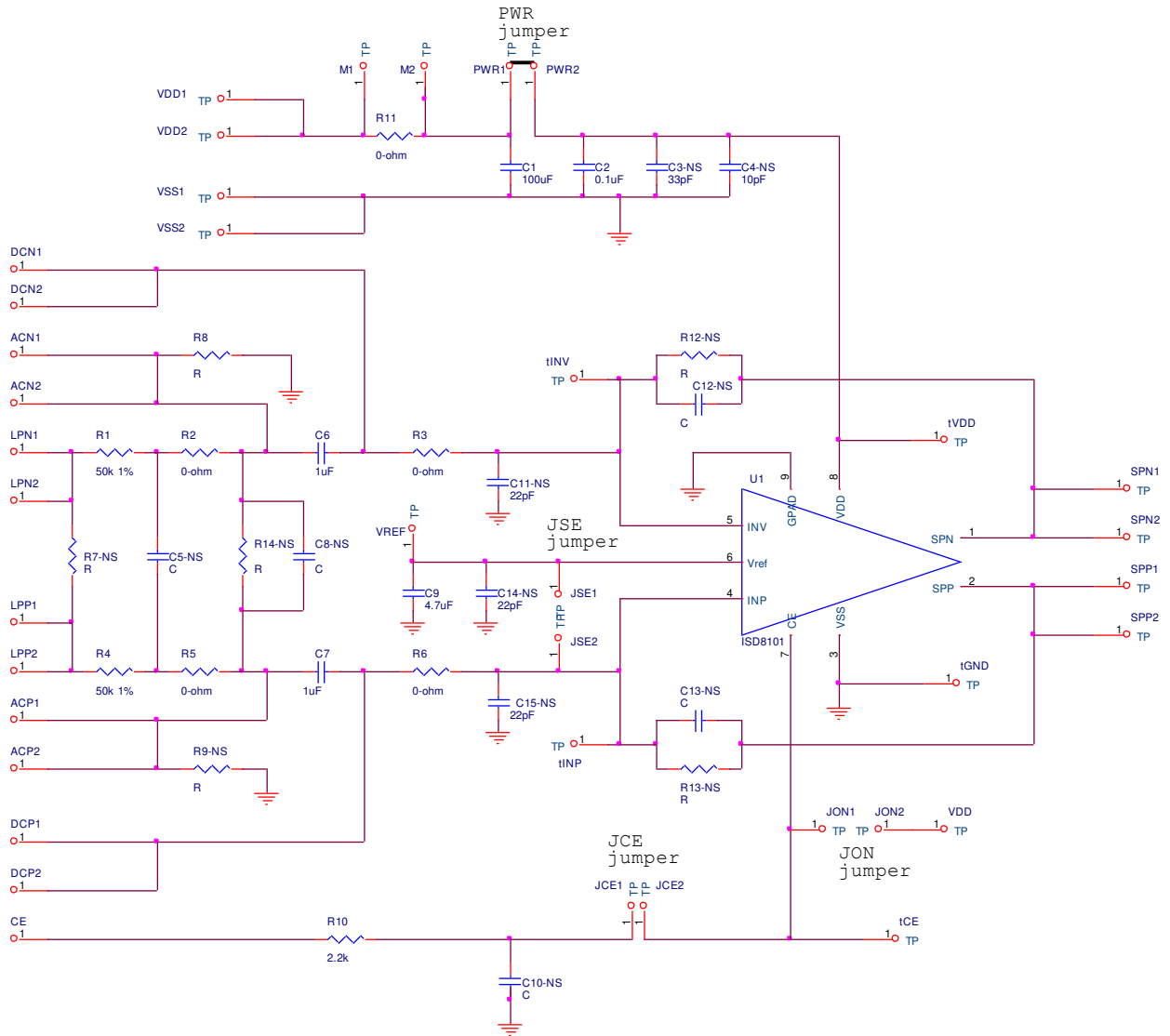

Figure 6: DIFFERENTIAL INPUT DESIGN, ALWAYS-ON CASE (CHIP ENABLE TIED TO Vdd)

EVB Schematic:



VERSION HISTORY

VERSION	DATE	PAGE	DESCRIPTION
Rev. 1.0	Sept 30, 2010	all	Initial Release

Important Notice

Nuvoton products are not designed, intended, authorized or warranted for use as components in systems or equipment intended for surgical implantation, atomic energy control instruments, airplane or spaceship instruments, transportation instruments, traffic signal instruments, combustion control instruments, or for other applications intended to support or sustain life. Furthermore, Nuvoton products are not intended for applications wherein failure of Nuvoton products could result or lead to a situation wherein personal injury, death or severe property or environmental damage could occur.

Nuvoton customers using or selling these products for use in such applications do so at their own risk and agree to fully indemnify Nuvoton for any damages resulting from such improper use or sales.