



Chipsmall Limited consists of a professional team with an average of over 10 year of expertise in the distribution of electronic components. Based in Hongkong, we have already established firm and mutual-benefit business relationships with customers from,Europe,America and south Asia,supplying obsolete and hard-to-find components to meet their specific needs.

With the principle of “Quality Parts,Customers Priority,Honest Operation,and Considerate Service”,our business mainly focus on the distribution of electronic components. Line cards we deal with include Microchip,ALPS,ROHM,Xilinx,Pulse,ON,Everlight and Freescale. Main products comprise IC,Modules,Potentiometer,IC Socket,Relay,Connector.Our parts cover such applications as commercial,industrial, and automotives areas.

We are looking forward to setting up business relationship with you and hope to provide you with the best service and solution. Let us make a better world for our industry!



## Contact us

Tel: +86-755-8981 8866 Fax: +86-755-8427 6832

Email & Skype: info@chipsmall.com Web: www.chipsmall.com

Address: A1208, Overseas Decoration Building, #122 Zhenhua RD., Futian, Shenzhen, China



## ISD-DEMO8102 User's Manual

### Introduction:

The ISD-DEMO8102 is a SOP8 demo board for ISD8102 series. It is available to demonstrate basic functionality and to make it easy to try different configurations of components and component values.

ISD-DEMO8102 includes two channels on the PCB, consisting of two ISD8102 ICs. They are typically used as the LEFT and RIGHT channels to perform stereo audio output. Users can utilize either LEFT or RIGHT side only for the mono audio operation. In the standard configuration, jumper pins are used to set the ISD-DEMO8102 to the normal operation.

The picture below illustrates all the input controls and BTL speaker as well as SE Headphone output.

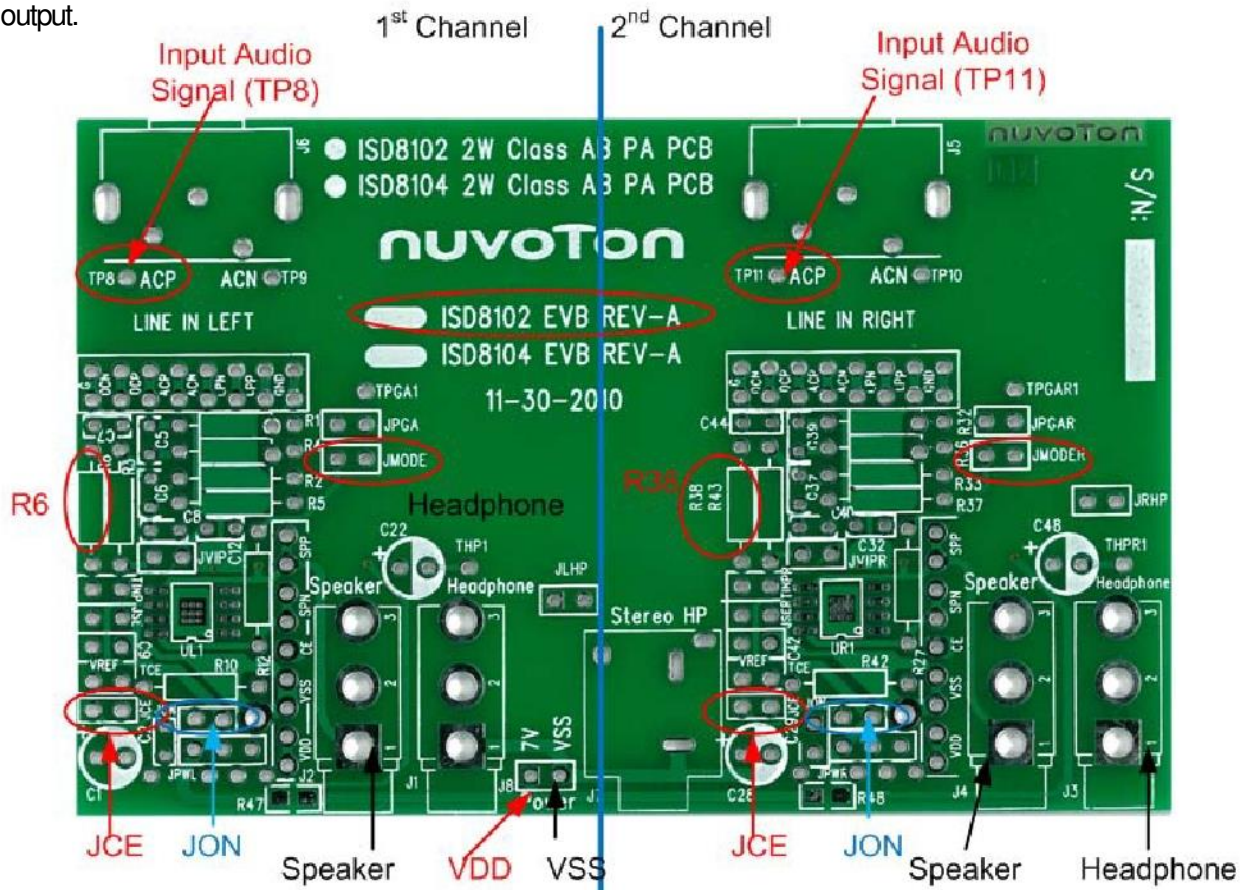

Figure 1: ISD-DEMO8102 EVB Pins and Jumpers Definition



Figure 2: ISD-DEMO8102 EVB Jumpers Setting

### Hardware Connections:

- Connect a 4Ω or larger loading speaker to **SPP** and **SPN**; otherwise, connect a 4Ω or larger loading speaker to **Speaker** plug.
- Connect a power supply to the related terminals (7V and VSS). Please ensure the polarity of the power is correct to avoid any damages to the ISD8102 device.
- **Jumper CEb** (LEFT and RIGHT): Connect the CEb (chip enable bar) input to GND, and ensure that CEb (pin1) is active LOW, as shown in the Figure 2.
- Jumper **MODE** (LEFT) and Jumper **MODER** (RIGHT): Ensure that the EVB is in the proper ISD8102 operation setting.
- Unity gain set of input: **LPN** is used for the single-ended low gain configuration.
- A 20dB gain set of input: **ACP(TP8 / TP11 - LEFT and RIGHT)** is used for the single-ended high gain configuration. The RCA (Lower Jack) can be used as the music signal source.
- Jumper **JON**: Power Down the ISD8102 IC since CEb is shorted to VDD. Note: Do **not** put Jumpers JON and JCE ON at the same time, as this will cause a SHORT CIRCUIT.

**Gain Configuration of ISD-DEMO8102 EVB:**

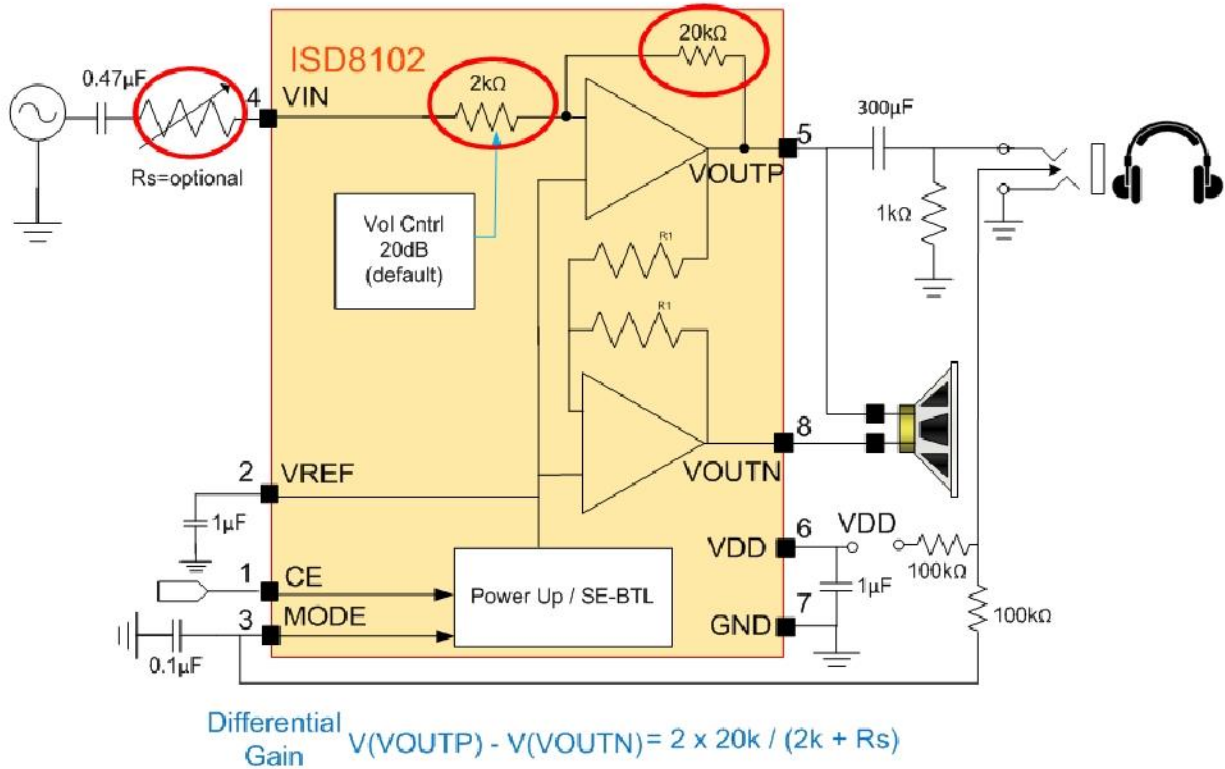

Figure 3: ISD8102 Application Diagram for the Headphone Sense Input

Single -Ended Gain (SPP) =  $20k\Omega / (2k\Omega + R_s)$

Case: Single Ended Gain = 4x;

$R_s = 3k\Omega$

Gain Setting Configuration:

- By default, ISD-DEMO8102 is set to 20dB gain of input ACP, and **R6** (LEFT Channel) and **R38** (RIGHT Channel) are 0Ω on the EVB, as shown in the Figure 1. The ACP single ended 20dB gain can be attenuated by changing the R6 and R38 resistance value, as demonstrated in the above equations.

**Pinout Configuration: SOP- 8**

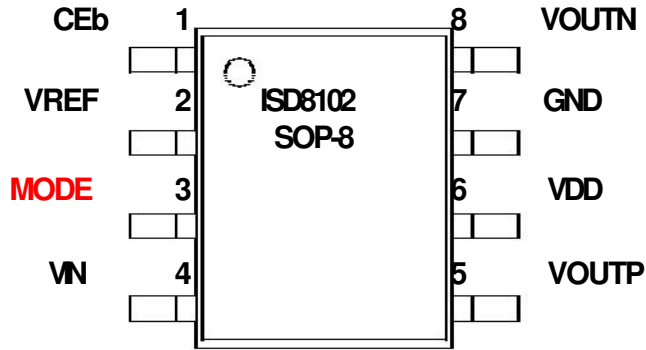

**PIN DESCRIPTION**

**Pin Number**

1	CEb	I	Chip Enable Bar (Low = Chip Power Up / High = Chip Power Down)
2	VREF	O	Internal Reference Voltage (1/2 Vdd)
3	MODE	I	Single-Ended / Differential Output Logic Control (Low = BTL mode / High = SE mode)
4	VIN	I	Inverting Signal Input
5	VOUTP	O	Non-Inverting Speaker Output
6	VDD	I	Supply Voltage
7	GND	I	Ground
8	VOUTN	O	Inverting Speaker Output





**Version History:**

VERSION	DATE	PAGE	DESCRIPTION
Rev. 1.0	April 2016	all	Initial Release

**Important Notice**

Nuvoton products are not designed, intended, authorized or warranted for use as components in systems or equipment intended for surgical implantation, atomic energy control instruments, airplane or spaceship instruments, transportation instruments, traffic signal instruments, combustion control instruments, or for other applications intended to support or sustain life. Furthermore, Nuvoton products are not intended for applications wherein failure of Nuvoton products could result or lead to a situation wherein personal injury, death or severe property or environmental damage could occur.

Nuvoton customers using or selling these products for use in such applications do so at their own risk and agree to fully indemnify Nuvoton for any damages resulting from such improper use or sales.