



Chipsmall Limited consists of a professional team with an average of over 10 year of expertise in the distribution of electronic components. Based in Hongkong, we have already established firm and mutual-benefit business relationships with customers from,Europe,America and south Asia,supplying obsolete and hard-to-find components to meet their specific needs.

With the principle of “Quality Parts,Customers Priority,Honest Operation,and Considerate Service”,our business mainly focus on the distribution of electronic components. Line cards we deal with include Microchip,ALPS,ROHM,Xilinx,Pulse,ON,Everlight and Freescale. Main products comprise IC,Modules,Potentiometer,IC Socket,Relay,Connector.Our parts cover such applications as commercial,industrial, and automotives areas.

We are looking forward to setting up business relationship with you and hope to provide you with the best service and solution. Let us make a better world for our industry!



## Contact us

Tel: +86-755-8981 8866 Fax: +86-755-8427 6832

Email & Skype: info@chipsmall.com Web: www.chipsmall.com

Address: A1208, Overseas Decoration Building, #122 Zhenhua RD., Futian, Shenzhen, China



# ES302 DEMONSTRATION BOARD



#### DEVICES SUPPORTED:

Products Supported	Ordering Code
ISD4002-120	ISD-ES302
ISD4002-150	ISD-ES302
ISD4002-180	ISD-ES302
ISD4002-240	ISD-ES302
ISD4003-04M	ISD-ES302
ISD4003-05M	ISD-ES302
ISD4003-06M	ISD-ES302
ISD4003-08M	ISD-ES302
ISD4004-08M	ISD-ES302
ISD4004-10M	ISD-ES302
ISD4004-12M	ISD-ES302
ISD4004-16M	ISD-ES302

#### CONTENTS OF KIT:

- Two AA Batteries
- 16 Ohm Speaker
- ES302 Demo board with user's guide
- Three ISD4003 PDIP Samples

#### OVERVIEW:

The ES302 Demo board is designed to let listeners hear the voice quality of the 3 volt part and to demonstrate some of the features available through the SPI bus control.

#### HARDWARE:

The three major Integrated Circuits on the board are the ISD4000 voice chip, U2, the NSC COP820C microcontroller, U4, and an audio chip, U3. The audio chip is an ISD1020 of which only the microphone preamplifier and the speaker driver are used. It is run on 5 V whereas the ISD4000 is run on 3 V. The audio chip would not normally be needed because the audio input and speaker output functions are already on the board in a cellular phone, for example. The board is powered by two AA cells on the bottom side. These cells drive a voltage converter to get the 5 V for the audio chip and the microcontroller. This voltage is then regulated down to 3 V (or 3.3 VDC) for the ISD4000 device.

#### SOFTWARE:

The COP microcontroller provides the interface between the user's fingers on the keyboard and the ISD4000 device. It interprets the key strokes and issues the appropriate commands to the ISD4000. It also monitors the ISD4000 status registers and Interrupt Output to keep track of operations.

## INSTRUCTIONS:

The keyboard on the ES302 Demo board consists of a 2 x 3 matrix of various colored keys. As with many microcontroller project boards, ISD has also provided the white MASTER\_RESET button at the bottom of the board in case of program lockup.

To operate the board, insert the desired ISD4000 product into the U2 socket. This can be any one of the four sample rates for comparison of the voice quality versus time duration listening. Power ON the board with S11 at the right hand side of the board. Up is the "ON" position. This applies the 3 V from the batteries to the converter chip. Check that the speaker is plugged into JP2 so that you can hear the results.

The six push-buttons are labeled on the PCB. Pushing the Yellow "**Go\_to\_Beg**" button will reset the address pointer to the front of the chip or address 000. The indication that this has been done will be a **double flash** of the LED, D11, in the bottom left corner of the PCB.

Pushing the Red "**Record**" button will turn on the Red LED to indicate that the chip is now recording anything it hears at the microphone **M1** near the top center of the board. The board will continue to Record until the end of the chip is reached or the **Black "Stop"** button is pressed. At that time the LED will go out and the board will stop Recording.

Pushing the White "**Play\_Last**" button (or pushing the Yellow "**Go\_to\_Beg**" button, and then the White "**Play\_Next**" button) will playback what you have just recorded. This message will play through to its end or stop when you press the Black "**Stop**" button.

The Blue "**Skip\_to\_Next**" button will let you bypass a message and play the one after that message. For example, had you recorded three messages, beginning at the front of the chip, and gone back to the beginning after the last message then you could press the White "**Play\_Next**" button to play message #1, press the Blue "**Skip\_tp\_Next**" button to bypass message #2 and then press the White "**Play\_Next**" to play message #3.

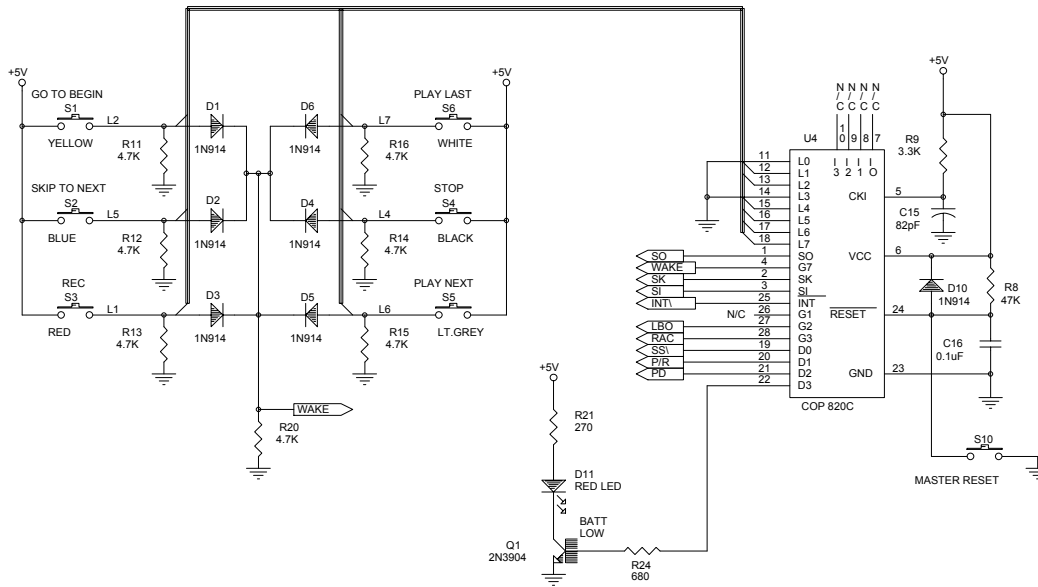
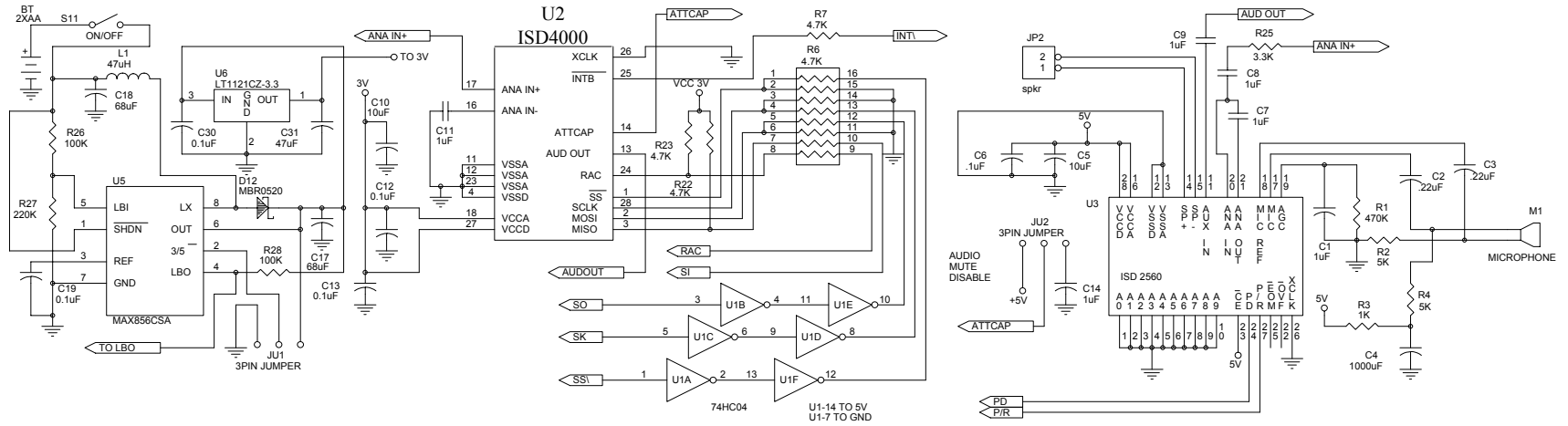

NOTES:  
 L1 IS A SUMIDA CD43-470-KC  
 D12 SUBSTITUTE 1N5817 SCHOTTKY

INFORMATION STORAGE DEVICES		
Title	ES302 DEMO BOARD	
Size B	Document Number	REV B
Date:	96-02-05 ES302 AB	1 of 1
	July 25, 1996	Sheet 1 of 1