



Chipsmall Limited consists of a professional team with an average of over 10 year of expertise in the distribution of electronic components. Based in Hongkong, we have already established firm and mutual-benefit business relationships with customers from,Europe,America and south Asia,supplying obsolete and hard-to-find components to meet their specific needs.

With the principle of “Quality Parts,Customers Priority,Honest Operation,and Considerate Service”,our business mainly focus on the distribution of electronic components. Line cards we deal with include Microchip,ALPS,ROHM,Xilinx,Pulse,ON,Everlight and Freescale. Main products comprise IC,Modules,Potentiometer,IC Socket,Relay,Connector.Our parts cover such applications as commercial,industrial, and automotives areas.

We are looking forward to setting up business relationship with you and hope to provide you with the best service and solution. Let us make a better world for our industry!



Contact us

Tel: +86-755-8981 8866 Fax: +86-755-8427 6832

Email & Skype: info@chipsmall.com Web: www.chipsmall.com

Address: A1208, Overseas Decoration Building, #122 Zhenhua RD., Futian, Shenzhen, China



ISL281X7MSOPEVAL1Z Evaluation Board User's Guide

Introduction

The ISL281X7MSOPEVAL1Z evaluation board is a design platform containing all the circuitry needed to characterize critical performance parameters of the ISL281X7 operational amplifiers in MSOP-8 package, using a variety of user defined test circuits.

The ISL281X7 operational amplifiers feature low bias current, low noise, and low offset and temperature drift.

Reference Documents

- ISL28107 Data Sheet, [FN6631](#)
- ISL28117 Data Sheet, [FN6632](#)
- ISL28127 Data Sheet, [FN6633](#)

Evaluation Board Key Features

The ISL281X7MSOPEVAL1Z is designed to enable the IC to operate from a single supply, +4.5VDC to +40VDC or from split supplies, ±2.25VDC to ±20V. The board is configured for a single op amp connected for differential input with a closed loop gain of 10. A single external reference voltage (VREF) pin and provisions for a user-selectable voltage divider-filter are included.

Power Supplies (Figure 1)

External power connections are made through the +V, -V, VREF and Ground connections on the evaluation board. For single supply operation, the -V and Ground pins are

connected together to the power supply negative terminal. For split supplies, +V and -V terminals connect to their respective power supply terminals. De-coupling capacitors C2 and C4 connect close to their respective supplies, while two additional capacitors, C1 and C5, are connected close to the part to filter out high frequency noise. Anti-reverse diodes D1 and D2 protect the circuit in the case of accidental polarity reversal.

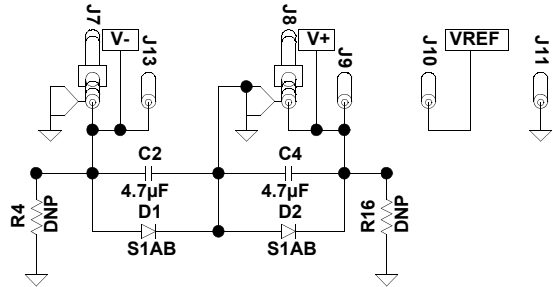

FIGURE 1. POWER SUPPLY CIRCUIT

Amplifier Configuration (Figure 2)

The schematic of 1/2 of the op amp with the components supplied is shown in Figure 2. The circuit implements a differential input amp with a closed loop gain of 10. The circuit can operate from a single supply or from dual supplies. The VREF pin must be connected to ground to establish a ground referenced input for dual supply operation, or can be externally set to any reference level for single supply operation. VREF should not be left floating.

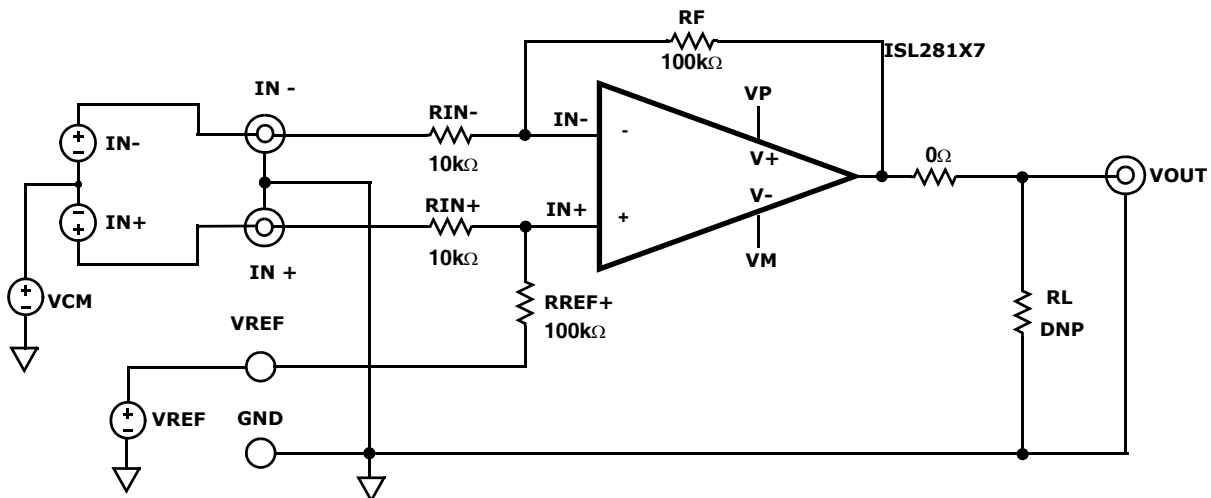

FIGURE 2. BASIC AMPLIFIER CONFIGURATION

User-selectable Options (Figures 3 and 4)

Component pads are included to enable a variety of user-selectable circuits to be added to the amplifier VREF, inputs, outputs, and the amplifier feedback loops. The Inputs (Figure 3) have additional resistor and capacitor, and jumper placements for loading and/or measurement of frequency sensitive parameters.

The outputs (Figure 4) have additional resistor and capacitor placements for filtering and loading.

NOTE: Operational amplifiers are sensitive to output capacitance and may oscillate. In the event of oscillation, reduce output capacitance by using shorter cables, or add a resistor in series with the output.

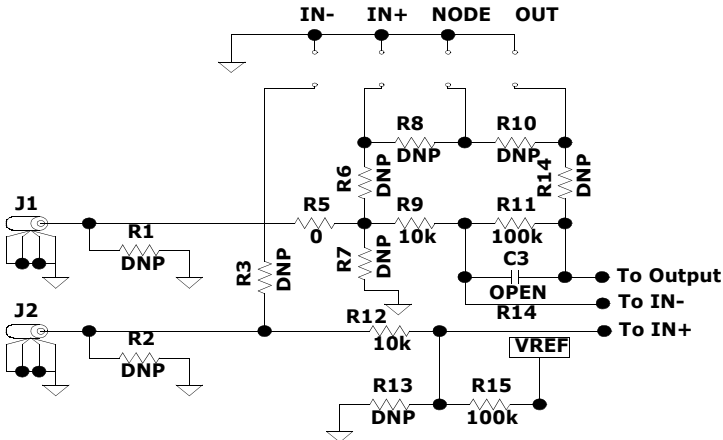

FIGURE 3. INPUT STAGE

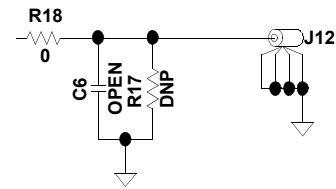

FIGURE 4. OUTPUT STAGE

TABLE 1. ISL281X7MSOPEVAL1Z COMPONENTS PARTS LIST

DEVICE #	DESCRIPTION	COMMENTS
C2, C4	CAP, SMD, 0805, 4.7μF, 50V, 10%, X7R, ROHS	Power Supply Decoupling
C1, C5	CAP, SMD, 0603, 0.01μF, 50V, 10%, X7R, ROHS	Power Supply Decoupling
C3, C6	CAP, SMD, 0603, DNP-PLACE HOLDER, ROHS	User selectable capacitors - not populated
D1, D2	DIODE-RECTIFIER, 40V, 0.5A, ROHS	Reverse Power Protection
U1 (ISL28107FUZ)	OP AMP, MSOP, ROHS	
U1 (ISL28117FUZ)	OP AMP, MSOP, ROHS	
U1 (ISL28127FUZ)	OP AMP, MSOP, ROHS	
R1-R4, R6-R8, R10, R13, R14, R16, R17, R19, R20	RESISTOR, SMD, 0603, 0.1%, MF, DNP-PLACE HOLDER	User selectable resistors - not populated
R5, R18	RES, SMD, 0603, 0Ω, 1/10W, TF, ROHS	Zero ohm user selectable resistors
R9, R12	RES, SMD, 0603, 10k, 1/10W, 1%, TF, ROHS	Gain resistors
R11, R15	RES, SMD, 0603, 100k, 1/10W, 1%, TF, ROHS	Gain resistors

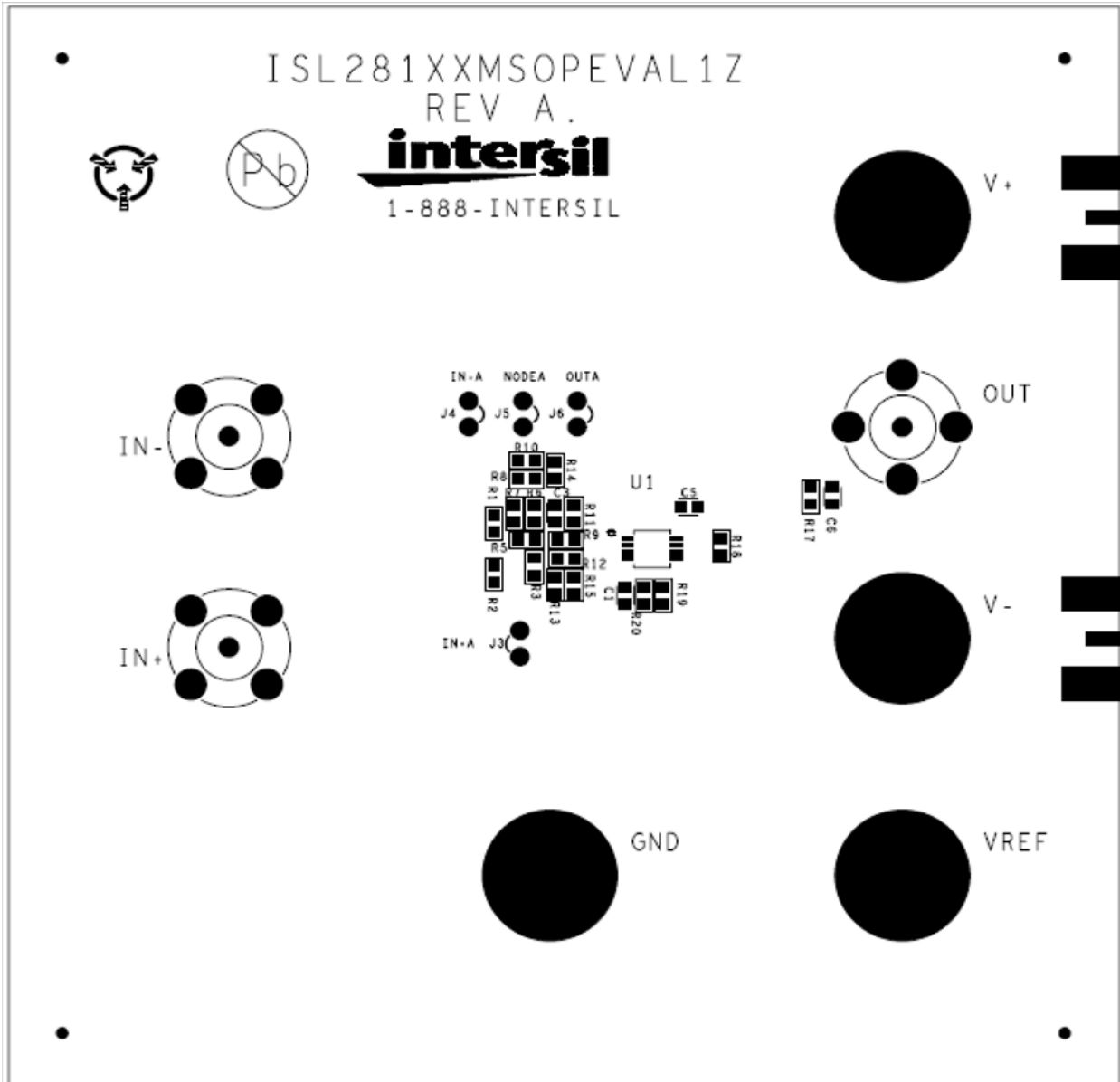

FIGURE 5. ISL281X7MSOPEVAL1Z TOP VIEW

Intersil Corporation reserves the right to make changes in circuit design, software and/or specifications at any time without notice. Accordingly, the reader is cautioned to verify that the Application Note or Technical Brief is current before proceeding.

For information regarding Intersil Corporation and its products, see www.intersil.com

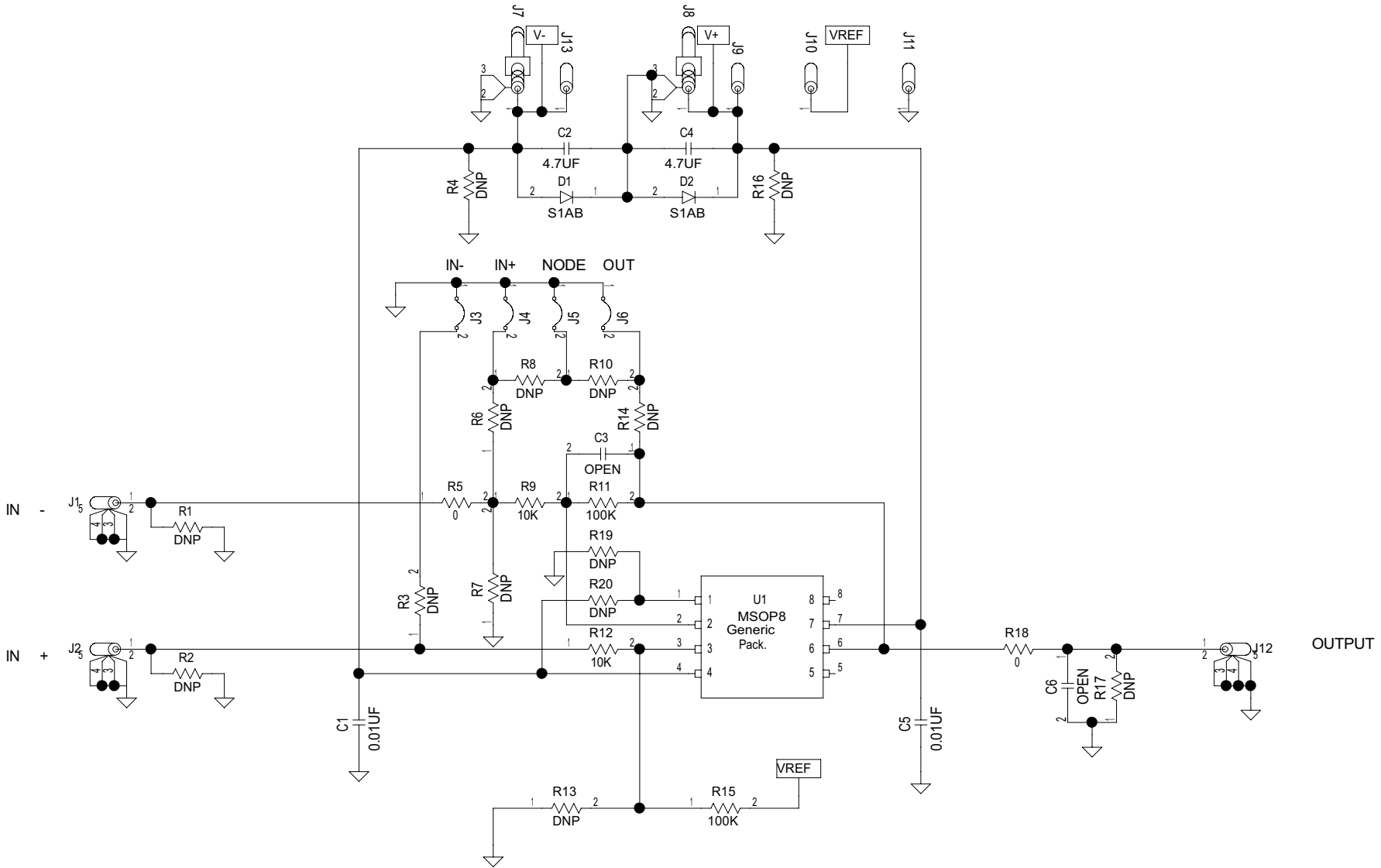

FIGURE 6. ISL281X7MSOPEVAL1Z SCHEMATIC DIAGRAM