



Chipsmall Limited consists of a professional team with an average of over 10 year of expertise in the distribution of electronic components. Based in Hongkong, we have already established firm and mutual-benefit business relationships with customers from,Europe,America and south Asia,supplying obsolete and hard-to-find components to meet their specific needs.

With the principle of “Quality Parts,Customers Priority,Honest Operation,and Considerate Service”,our business mainly focus on the distribution of electronic components. Line cards we deal with include Microchip,ALPS,ROHM,Xilinx,Pulse,ON,Everlight and Freescale. Main products comprise IC,Modules,Potentiometer,IC Socket,Relay,Connector.Our parts cover such applications as commercial,industrial, and automotives areas.

We are looking forward to setting up business relationship with you and hope to provide you with the best service and solution. Let us make a better world for our industry!



Contact us

Tel: +86-755-8981 8866 Fax: +86-755-8427 6832

Email & Skype: info@chipsmall.com Web: www.chipsmall.com

Address: A1208, Overseas Decoration Building, #122 Zhenhua RD., Futian, Shenzhen, China



ISL28133ISENSEV1Z Evaluation Board User's Guide

The ISL28133ISENSEV1Z evaluation board contains a complete precision current sense amplifier using the ISL28133 chopper amplifier in a high side, low side of floating supply current sense application.

The advantages of the ISL28133 in this application include very low offset voltage (2μV typical) and offset drift (0.07μV/°C), rail-to-rail input and output and low power consumption (18μA typical). These features provide a very high degree of precision for use in 5V, low power applications.

Reference Documents

- ISL28133 Data Sheet ([FN6560](#))

Evaluation Board Key Features

The ISL28133ISENSEV1Z operates from a single 1.65VDC to +5.5VDC supply. The current sense function is configured as a single stage, balanced input, trans-impedance amplifier. A 0.1Ω 0.1% current sense resistor is used convert the incoming current to a voltage which is applied to a precision differential amplifier with a gain of 100. The overall current to voltage transfer ratio is 10V/A, and a bidirectional current range of ±0.25A is achieved when operating from a +5V supply, using a 2.5V reference voltage (V_{REF}). At +25°C, the ISL28133 achieves a total full scale offset error of 0.038% (when a precision external reference is used) and approximately 0.15% using the internal 0.1% resistors.

The total current draw from the amplifier power is less than 35μA and the total leakage current from the current sense input is less than 3μA.

Power Supply and Protection Features

External power connections are made through the +V, and ground jacks. The single supply input is overvoltage protected using a series 100Ω resistor and a 5.6V zener diode (D1). Reverse polarity protection uses the 100Ω resistor and two protection diode pairs (D3, D4). These also provide input common mode voltage protection to the op amp.

Input Protection Clamp Options

Included on the evaluation board are optional input protection circuits that illustrate the best methods to limit input common mode and differential transient voltage spikes in exposed or electrically hazardous applications. The ISL28133 can handle input common mode and differential transients to a diode drop beyond the rails, or to a range of -0.5V to +5.5V when operating from a single 5V supply.

Clamp diodes D3A, B, D4A, B and input resistors R6, R7, R8, R9 form a current limiting, 6V common mode and differential voltage clamp. This clamp provides sufficient protection for the ISL28133 for common mode fault voltages far beyond the power supply rails. These diodes also provide the same 6V protection against large differential transients.

High speed current sensing may involve filtering repetitive current transients with high peak to average values. In these cases, limiting these transient even further will improve amplifier response and overload settling time. The optional Schottky diode transient clamp D2 reduces transients let through by the common mode clamp from 6V down to ~ ±0.3V, which improves overload recovery time. Capacitors C7 and C9 provide common mode noise filtering and capacitor C8 can be used to filter the current sense signal.

Current Sense Gain Equations

The current sense amplifier in Figure 1 forms a trans-impedance amplifier whose gain is in units of V/A and is determined by the ratios of resistor pairs. R11:R8 and R14:R9. Resistor R11 is set equal to R14 and R8 is set equal to R9. This matching cancels the input offset voltage errors caused by the op amp input bias currents, leaving behind only the offset voltage errors caused by the ISL28133 input offset current (I_{OS}).

The I_{SENSE} to V_{OUT} DC transfer function is given by Equation 1:

$$V_{OUT} = \left[I_{SENSE} \times R_{SENSE} \times \frac{R14}{R9} \right] + V_{REF} \quad (EQ. 1)$$

where:

$$R11 = R14 \text{ and } R6 + R8 = R7 + R9$$

On the evaluation board, the R12, R9 resistor ratio is 100:1 (499kΩ: 4.9kΩ), and R_{SENSE} is 0.1Ω for a trans-impedance gain given by Equation 2:

$$\frac{V_{SENSE}}{I_{SENSE}} = 10 \frac{V}{A} \quad (EQ. 2)$$

Input Range and Offset Error Analysis

The ISL28133 output swings from rail-to-rail, and the evaluation board has a bi-directional output range of V_{REF} ±2.5V when operated from a +5V supply and V_{REF} is set to V_S/2. The evaluation board contains a jumper-selectable, internal V_S/2 reference or an external reference (V_{REF} pin). With V_{REF} set to +2.5, the full scale output range is 0 ±0.25A.

The very low offset voltage (±8μV +25°C max) and offset current (300pA +25°C max) of the ISL28133 enable the use of very high values resistors for low current consumption while maintaining excellent precision in battery operated circuits. The total offset voltage contribution of the ISL28133 is the sum of the input offset voltage (V_{OS}) and the offset voltage produced by the input offset current (I_{OS}) through the gain resistors and using the evaluation board resistor values and the data sheet maximum +25°C V_{OS} gives the total input offset voltage as shown in Equations 3, 4 and 5:

$$V_{OS(Total)} = \left(I_{OS} \times \left[\frac{R14 \times R9}{R14 + R9} \right] \right) + V_{OS} \quad (EQ. 3)$$

Application Note 1480

$$V_{OS(Total)} = \left(3e-10 \times \left[\frac{R14 \times R9}{R14 + R9} \right] \right) + 8\mu V \quad (EQ. 4)$$

$$V_{OS(Total)} = (3e-10 \times 4950) + 8\mu V = 9.5\mu V \quad (EQ. 5)$$

Multiplying the ISL28133 input offset voltage by the amplifier gain allows the input offset error to be expressed as a percent of full scale output voltage.

$$\% \text{ F.S. Error} = \frac{\left(V_{OS} \times \frac{R14}{R9} \right)}{\pm 2.5V} = \pm 0.038\% \quad (EQ. 6)$$

Using the Evaluation Board

The evaluation board has separate connections for the amplifier power supply, an output zero reference (V_{REF}), and the current sense terminals. The correct inter-connection between the I-SENSE terminals and the V_{REF} terminals are needed to implement the different types of current sense configurations.

The I-SENSE + and I-SENSE - connections to the measured circuit determine the polarity of the amplifier output voltage.

Establishing a current flow from the I-SENSE + to I-SENSE - causes the output voltage to increase in proportion to the input current. Reversing the I-SENSE current flow reverses the output polarity.

The voltage applied to the V_{REF} pin defines the amplifier output zero current level, and must be between 0V and +5V. For bi-directional current sensing, a reference midway between the ground and the supply voltage will maximize the output span. For example, a $V_{REF} = +2.5V$ would be the best choice for +5V power supply. The jumper selectable internal voltage divider is provided for this internal reference. The +2.5V will establish an output current scale setting $0A = +2.5V$, but the accuracy is determined by the voltage divider accuracy (0.1% resistors on the evaluation board). Connecting the jumper to the external reference position enables an external reference source to be used.

Figure 2 shows the connections to implement a high side, bi-directional current sense with the ability to monitor the charging current. Figure 3 shows the connection for uni-directional ground referenced current sensing. The ISL28133 maintains precision performance from rail-to-rail making precision ground-side sensing possible.

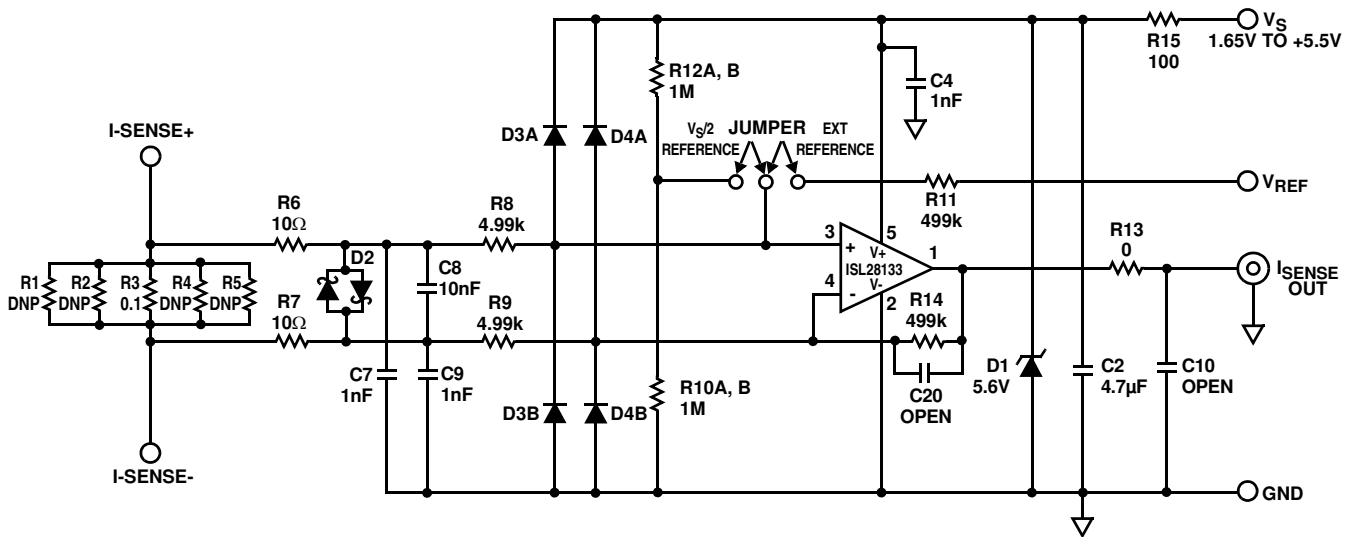

FIGURE 1. ISL28133 DIFFERENTIAL CURRENT SENSE AMPLIFIER

Application Note 1480

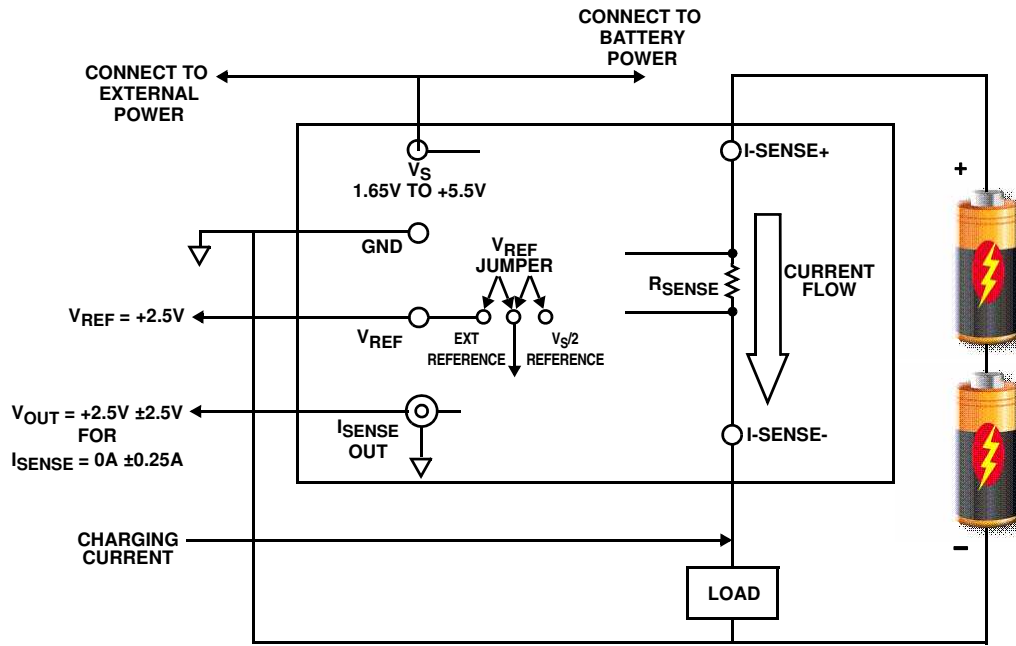

FIGURE 2. CURRENT SENSE FOR HIGH-SIDE BI-DIRECTIONAL RE-CHARGABLE BATTERY SUPPLY

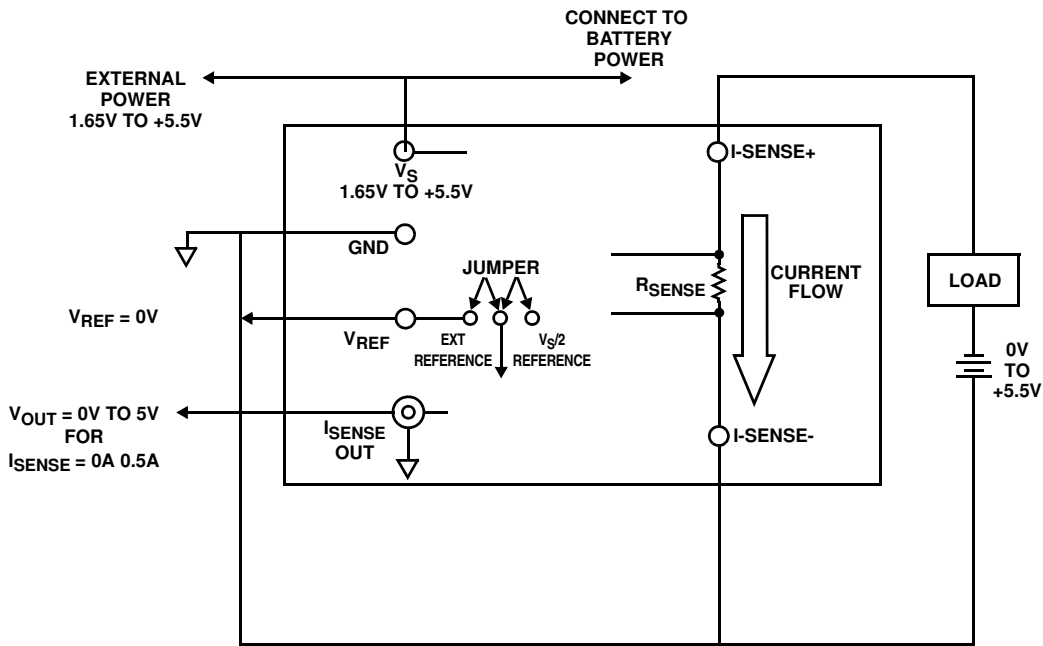

FIGURE 3. CURRENT SENSE FOR LOW SIDE UNI-DIRECTIONAL MEASUREMENT

Application Note 1480

ISL28133ISENSEV1Z Components Parts List

DEVICE #	DESCRIPTION	COMMENTS
C2	CAP-SMD, 0805, 4.7 μ F, 50V, 10%, X7R, ROHS	Power supply decoupling
C4, C7, C9	CAP, SMD, 0603, 1000F, 25V, 10%, X7R, ROHS	Power supply decoupling
C8	CAP, SMD, 0603, 0.1 μ F, 25V, 10%, X7R, ROHS	Power supply decoupling
C10, C20	CAP, SMD, 0603, DNP-PLACE HOLDER, ROHS	User-selectable capacitors - not populated
D1	Zener Diode ROHS	Reverse power protection
D2- D4	DIODE-SCHOTTKY BARRIER, SMD, SOT-23, 3P, 40V, ROHS	Reverse power protection
R13	RESISTOR, SMD, 0603, 0 Ω , 1/16W, 0.1%, TF, ROHS	0 Ω user selectable resistors
R1- R5	RES, SMD, 0805, 0.1 Ω , 1/10W, 0.1%, TF, ROHS	Current sense resistors
R6, R7	RES, SMD, 0805, 10 Ω , 1/10W, 0.1%, TF, ROHS	Protection resistors
R15	RES, SMD, 0805, 100 Ω , 1/10W, 0.1%, TF, ROHS	Protection resistors
R8, R9	RES, SMD, 0805, 4.99k Ω , 1/10W, 0.1%, TF, ROHS	0 Ω user selectable resistors
R11, R14, R10A, R10B, R12A, R12B	RES, SMD, 0805, 499k Ω , 1/10W, 0.1%, TF, ROHS	Gain and other user selectable resistors
U1 (ISL28133FHZ-T7)	IC-5 MHz, RRIO OP AMP, SOT23_5, ROHS	
R1, R2, R4, R5	RES, SMD, 0805, DNP	Optional sense resistors

ISL28133ISENSEV1Z Schematic Diagram

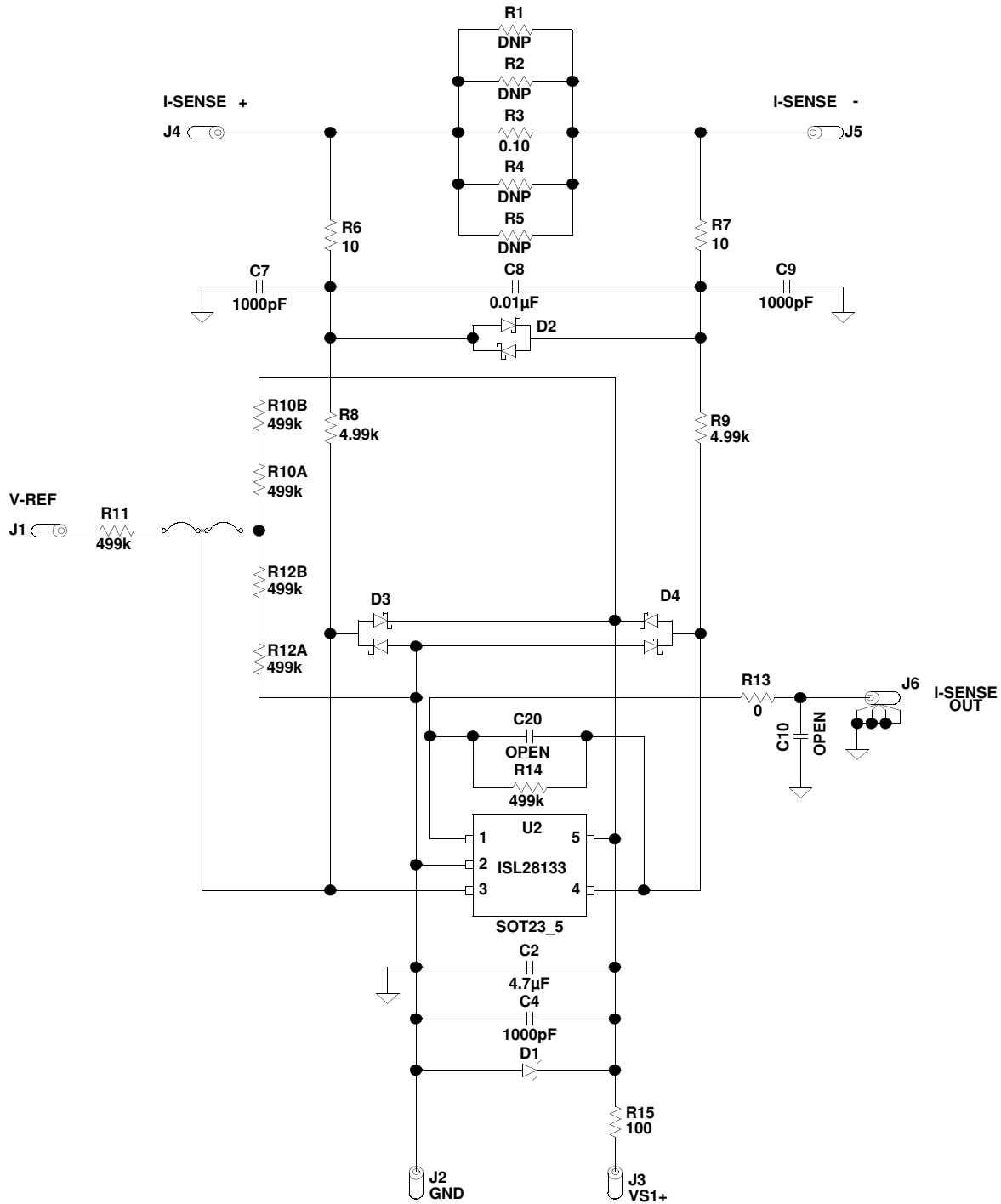

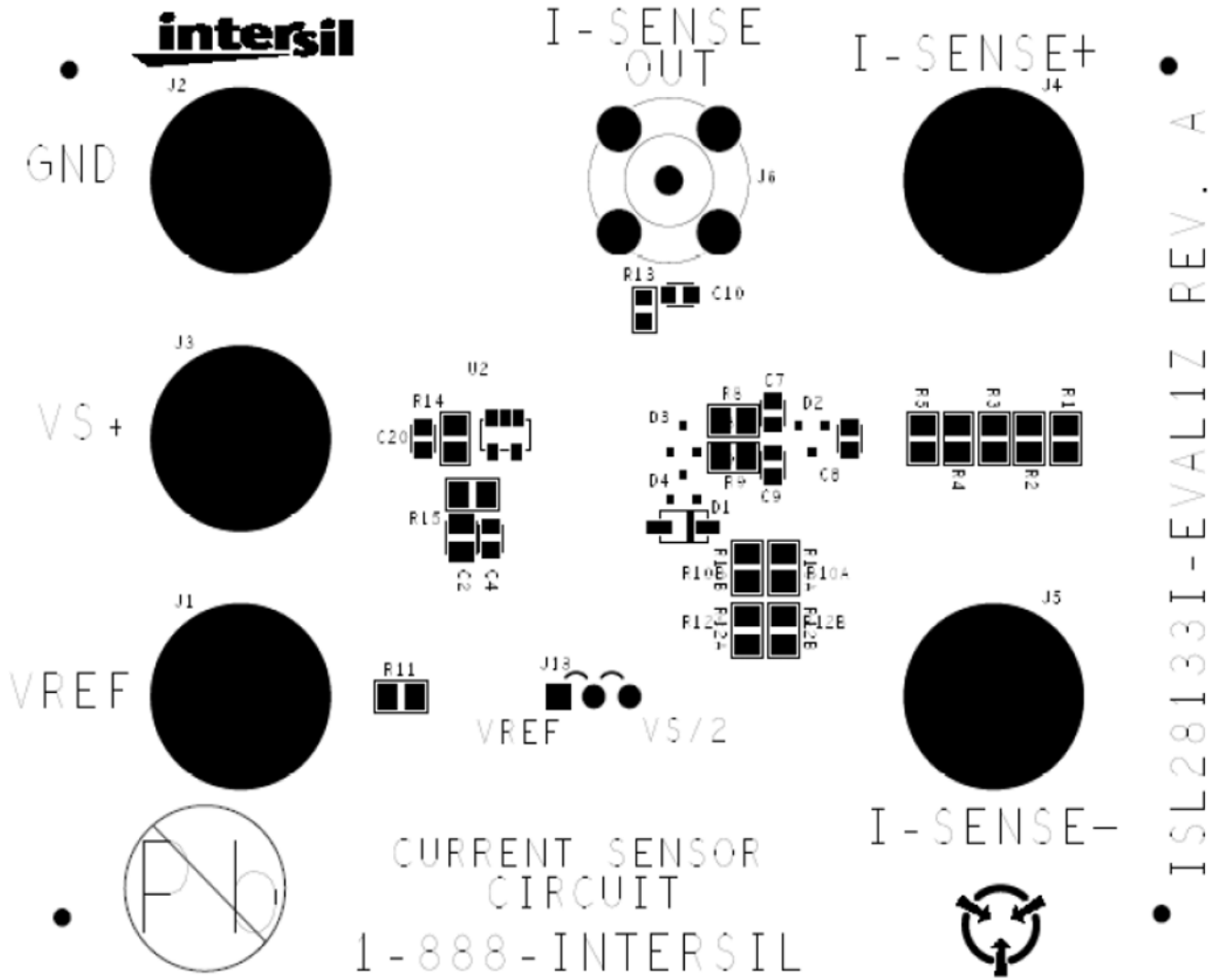

FIGURE 4. ISL28133ISENSEV1Z TOP VIEW

Intersil Corporation reserves the right to make changes in circuit design, software and/or specifications at any time without notice. Accordingly, the reader is cautioned to verify that the Application Note or Technical Brief is current before proceeding.

For information regarding Intersil Corporation and its products, see www.intersil.com