



Chipsmall Limited consists of a professional team with an average of over 10 year of expertise in the distribution of electronic components. Based in Hongkong, we have already established firm and mutual-benefit business relationships with customers from,Europe,America and south Asia,supplying obsolete and hard-to-find components to meet their specific needs.

With the principle of “Quality Parts,Customers Priority,Honest Operation,and Considerate Service”,our business mainly focus on the distribution of electronic components. Line cards we deal with include Microchip,ALPS,ROHM,Xilinx,Pulse,ON,Everlight and Freescale. Main products comprise IC,Modules,Potentiometer,IC Socket,Relay,Connector.Our parts cover such applications as commercial,industrial, and automotives areas.

We are looking forward to setting up business relationship with you and hope to provide you with the best service and solution. Let us make a better world for our industry!



## Contact us

Tel: +86-755-8981 8866 Fax: +86-755-8427 6832

Email & Skype: info@chipsmall.com Web: www.chipsmall.com

Address: A1208, Overseas Decoration Building, #122 Zhenhua RD., Futian, Shenzhen, China



# Low Side Precision Current Sense Amplifier

## Introduction

The ISL28134ISENSEV1Z evaluation board is designed specifically for low side current sensing up to 10A of current. The evaluation board uses a 1mΩ current sense resistor that is capable of handling 4W of power dissipation. The ISL28134 Precision Low Noise Zero Drift Amplifier gains the current sensing input signal and can be used to directly drive ADC inputs.

The ISL28134ISENSEV1Z evaluation board is optimized to operate at +5V. An ISL21090 Precision Low Noise 2.5V voltage reference sets a zero current reading of 2.5V at the amplifier output to interface with ADCs operating at 5V. The voltage reference also raises the common mode input by approximately 40mV above GND at zero current flow. This connection enables bi-directional current sensing, allowing the sense voltage to be positive or negative relative to the common mode voltage. This is helpful for applications such as the charging/discharging current from an Electric Vehicle battery or motors that switch polarity.

With the input common mode at 40mV above ground and a 1mΩ sense resistor, this allows ±40A current sensing before amplifier saturation. However, due to PCB copper resistance causing error at high currents, the recommended current sense is ±10A.

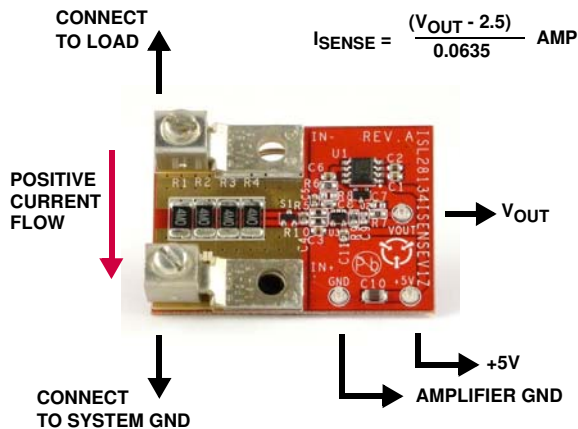

FIGURE 1. ISL28134ISENSEV1Z EVALUATION BOARD

## Board Layout

The evaluation board is laid out with heavy duty screw lug terminals that allow connections of wires up to 6 AWG. The 1mΩ sense resistance is formed from four 4mΩ 2512 style resistors to increase power dissipation capacity of the sense circuitry. The total power dissipation critically allowed is 4W. The PCB board is made using 2oz copper PCB with the current path routed on the top and bottom layer, minimizing trace resistance to maintain accurate current sense resistance. To further reduce sense errors, the current sensing uses a Kelvin

connection with the sense voltage pick up points at the center of the current density distribution.

Amplifier U3 gains up the voltage drop developed across the sense resistor from the current flow. Voltage Reference sets the zero current reading output of the amplifier at 2.5V.

## Quick Setup Guide

1. Connect single supply +5VDC to +5V and GND terminals.
2. Connect low side load to terminal lugs. Current flow from top to bottom of board.
3. At no load, V<sub>OUT</sub> is 2.5V.
4. With 1mΩ sense resistance and amplifier gain of 63.5V/V, the sense current reading is: (V<sub>OUT</sub> - 2.5V)/0.0635 in Amps.

REF	PART NUMBER	COMMENTS
U1	ISL21090	Ultra Low Noise 2.5V Voltage Reference
U2	DNP	Not populated on board
U3	ISL28134	Ultra Low Noise Zero Drift Amplifier

CURRENT SENSE SPECIFICATIONS	
Supply Voltage Range	3.0V to 5.0V Optimized for 5V Operation
Max Sense Current	±10A recommended ±40A Before Amplifier Saturation
Abs Max Sense Current	60 Amps Thermally Limited by Sense Resistor
Current Sense Resolution	±5mA
Current Sense Accuracy	2%
Voltage to Current Conversion	$I_{SENSE} = (V_{OUT} - 2.5V) / 0.0635 \text{ Amps}$
Amplifier Bandwidth	10kHz

## Measuring Very High Current

The reference design is capable of sensing currents greater than ±40A, however, it is limited mechanically from the temperature rise of the copper PCB layout and current sense resistor and limited electrically by amplifier saturation. One must consider the temperature rise of the PCB trace from the power dissipated under high currents, which may cause the copper trace to delaminate. The high current carrying PCB trace is made with 2oz copper on FR4 board both top and bottom layers. The trace dimension is approximately 25mm width and 40mm length. Substantial vias are used to connect the planes for lower thermal impedance. The current sense resistance is capable of 4W dissipation max.



## Bill of Materials

PART NUMBER	REFERENCE DESIGNATOR	DESCRIPTION	MANUFACTURER	MANUFACTURER PART
ISL21090BFB825Z	U1	Low Noise 2.5V Voltage Reference, SOIC-8	INTERSIL	ISL21090BFB825Z-TK
DNP	U2	DO NOT POPULATE		
ISL28134FHZ	U3	Low Noise Zero Drift Amplifier, SOT-23	INTERSIL	ISL28134FHZ
H1045-00101-50V5-T	C8,C9	CAP, SMD, 0603, 100pF, 50V, 5%, COG, ROHS	GENERIC	
H1045-00102-50V5-T	C4	CAP, SMD, 0603, 1000pF, 50V, 5%, COG, ROHS	GENERIC	
H1045-00103-50V10-T	C1, C3, C5, C6, C11	CAP, SMD, 0603, 0.01µF, 50V, 10%, X7R, ROHS	GENERIC	
H1045-00104-50V10-T	C2	CAP, SMD, 0603, 0.1µF, 50V, 10%, X7R, ROHS	GENERIC	
H1045-DNP	C7	CAP, SMD, 0603, DNP-PLACE HOLDER, ROHS		
H1065-00475-50V10-T	C10	CAP, SMD, 1206, 4.7µF, 50V, 10%, X5R, ROHS	GENERIC	
BAV99LT1G-T	S1	DIODE-SWITCHING, SMD, SOT23, 70V, 0.2A, ROHS	ON SEMICONDUCTOR	BAV99LT1G
H2511-00R00-1/10W-T	R7	RES, SMD, 0603, 0Ω, 1/10W, TF, ROHS	GENERIC	
H2511-01623-1/10W1-T	R6, R9	RES, SMD, 0603, 162k, 1/10W, 1%, TF, ROHS	GENERIC	
H2511-02551-1/10W1-T	R5, R10	RES, SMD, 0603, 2.55k, 1/10W, 1%, TF, ROHS	GENERIC	
H2511-DNP	R8	RES, SMD, 0603, DNP-PLACE HOLDER, ROHS		
H2515-0R004-1W1-T	R1-R4	RES, SMD, 2512, 0.004Ω, 1W, 1%, TF, ROHS	GENERIC	

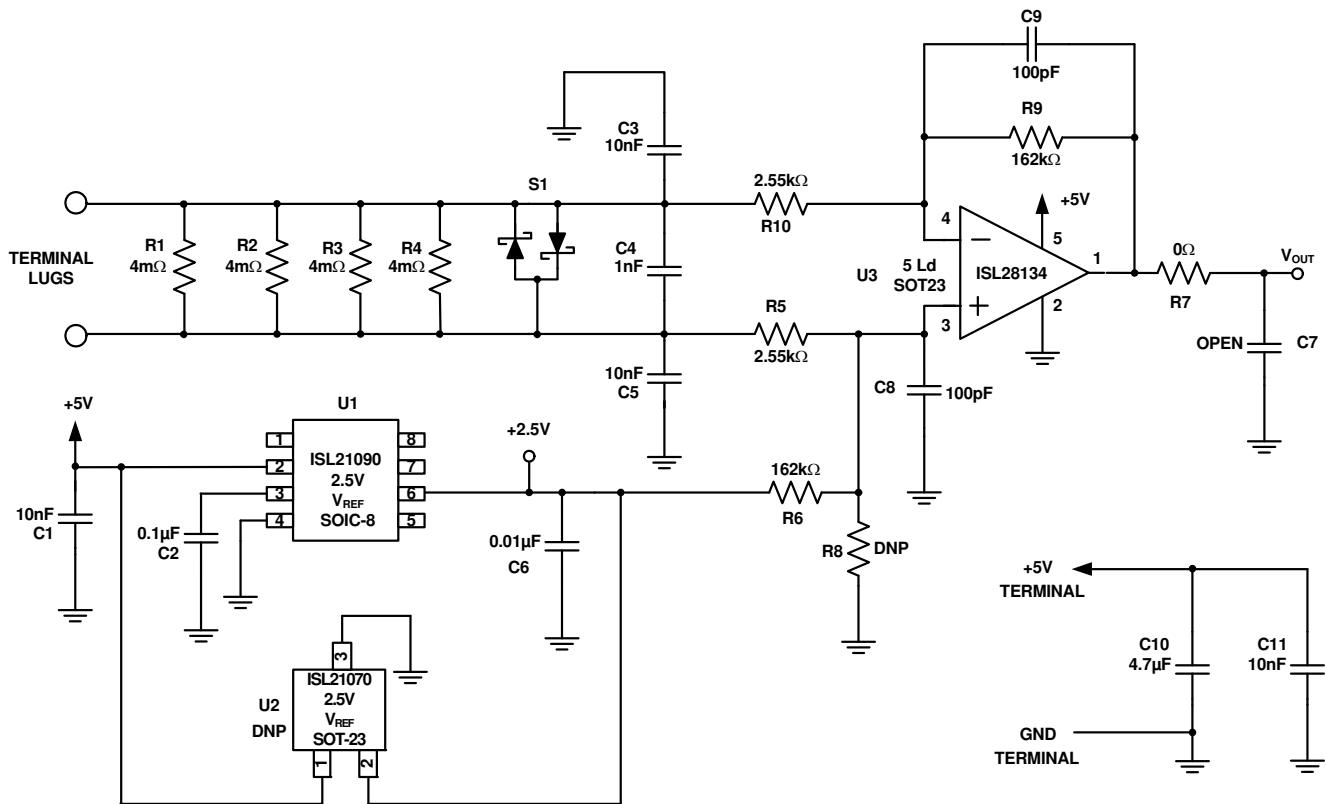

FIGURE 2. CURRENT SENSE AMPLIFIER SCHEMATIC

# Application Note 1777

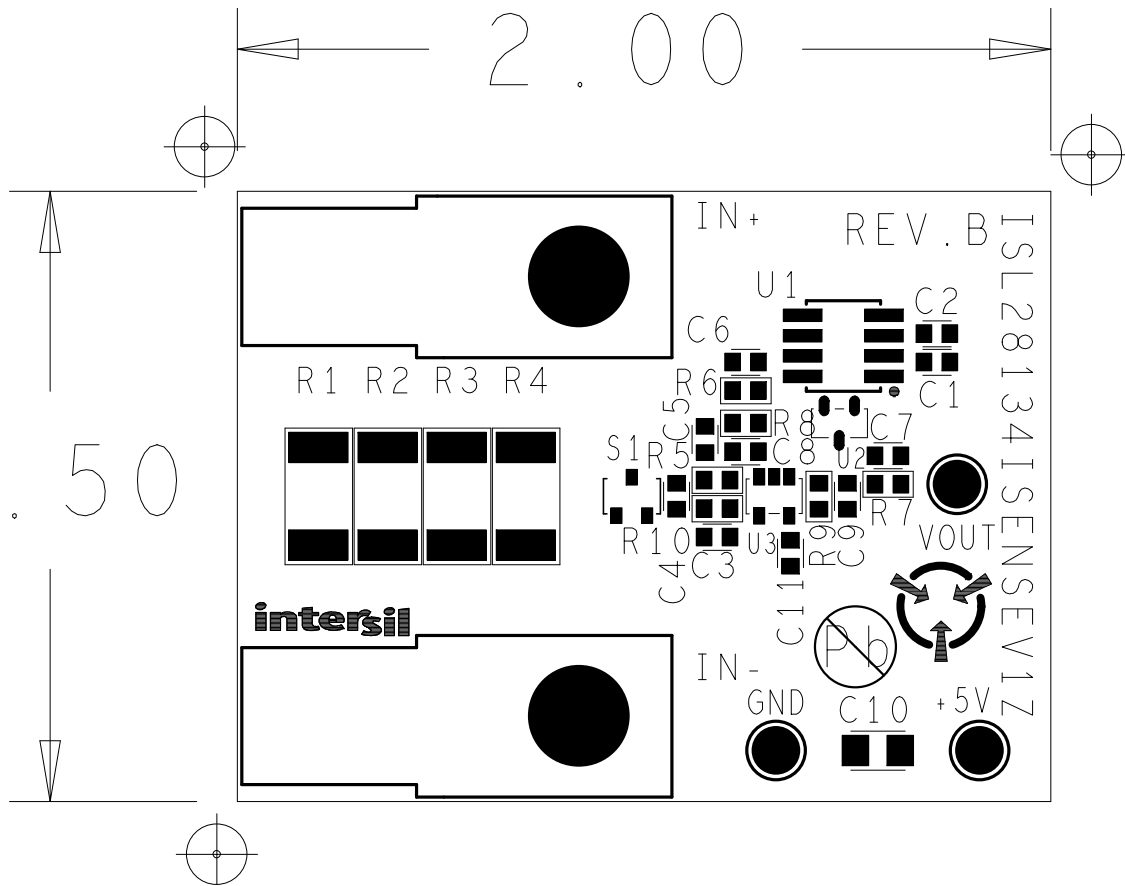

FIGURE 3. CURRENT SENSE AMPLIFIER ASSEMBLY DRAWING

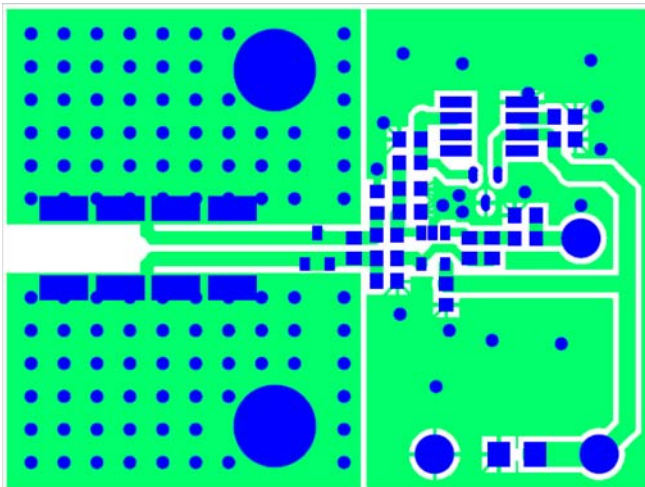

FIGURE 4. PCB TOP LAYER

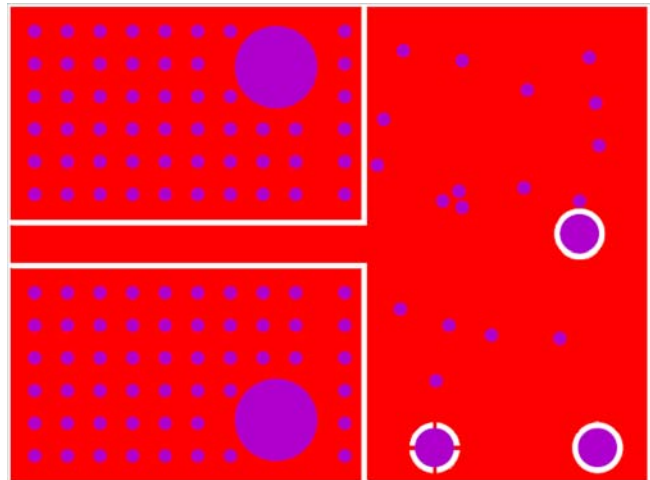

FIGURE 5. PCB BOTTOM LAYER

Intersil Corporation reserves the right to make changes in circuit design, software and/or specifications at any time without notice. Accordingly, the reader is cautioned to verify that the Application Note or Technical Brief is current before proceeding.

For information regarding Intersil Corporation and its products, see [www.intersil.com](http://www.intersil.com)