



Chipsmall Limited consists of a professional team with an average of over 10 year of expertise in the distribution of electronic components. Based in Hongkong, we have already established firm and mutual-benefit business relationships with customers from,Europe,America and south Asia,supplying obsolete and hard-to-find components to meet their specific needs.

With the principle of "Quality Parts,Customers Priority,Honest Operation,and Considerate Service",our business mainly focus on the distribution of electronic components. Line cards we deal with include Microchip,ALPS,ROHM,Xilinx,Pulse,ON,Everlight and Freescale. Main products comprise IC,Modules,Potentiometer,IC Socket,Relay,Connector.Our parts cover such applications as commercial,industrial, and automotives areas.

We are looking forward to setting up business relationship with you and hope to provide you with the best service and solution. Let us make a better world for our industry!



## Contact us

Tel: +86-755-8981 8866 Fax: +86-755-8427 6832

Email & Skype: info@chipsmall.com Web: www.chipsmall.com

Address: A1208, Overseas Decoration Building, #122 Zhenhua RD., Futian, Shenzhen, China



# ISL28134SOICEVAL1Z Evaluation Board User's Guide

## Introduction

The ISL28134SOICEVAL1Z Evaluation Board is designed to evaluate the performance of the ISL28134 Low Noise Chopper Stabilized op amp. The evaluation board contains the circuitry needed to evaluate the high performance of the ISL28134 amplifier. The ISL28134 chopper stabilized rail-to-rail input/output amplifier features a low 2.5µV maximum  $V_{OS}$  and 15nV/°C drift over-temperature. The amplifier has no 1/f noise corner down to 0.1Hz with a 1kHz voltage noise density of 10nV/√Hz. The high open loop gain of 174dB allows a high gain single-stage DC amplifier that can operate from a 3V single cell battery while consuming 700µA of current. The ISL28134SOICEVAL1Z evaluation board can be configured as a precision high-gain ( $G = 1,000V/V$ ) differential amplifier to demonstrate the level of performance possible with this amplifier.

## Reference Documents

- [ISL28134](#) Data Sheet

## Evaluation Board Key Features

- Single Supply Operation: +2.25V to +6.0V
- Dual Supply Operation: ±1.125V to ±3.0V
- Singled-Ended or Differential Input Operation with High Gain ( $G = 1,000V/V$ )
- Banana Jack Connectors for Power Supply Inputs
- BNC Connectors for Op Amp Input and Output Terminals
- Convenient PCB pads for changing gain configurations, filtering and impedance loading.
- External VREF Input

## Power Supplies (Figure 1)

External power connections are made through the V+, V-, and GND connections on the evaluation board. The circuit can operate from a single supply or from dual supplies. For single supply operation, the V- and GND pins are tied together to the negative or ground reference of the power supply. For split supplies, V+ and V- terminals connect to their respective supply terminals. The evaluation board power supply range is from +2.25V to +5.5V or ±1.125V to ±2.75V. De-coupling capacitors C2 and C4 provide low-frequency power-supply filtering, while additional capacitors, C1 and C5, which are connected close to the part, filter out high frequency noise. Anti-reverse diodes D1 and D2 protect the circuit in the momentary case of accidentally reversing the power supplies to the evaluation board.

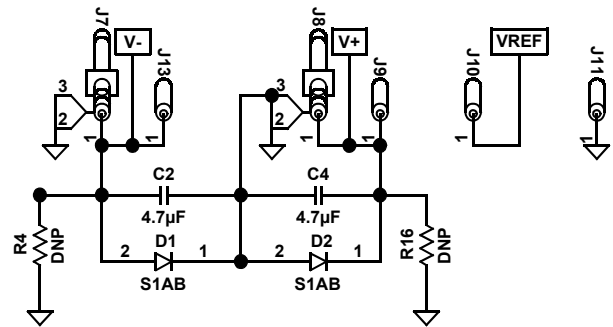

FIGURE 1. POWER SUPPLY CIRCUIT

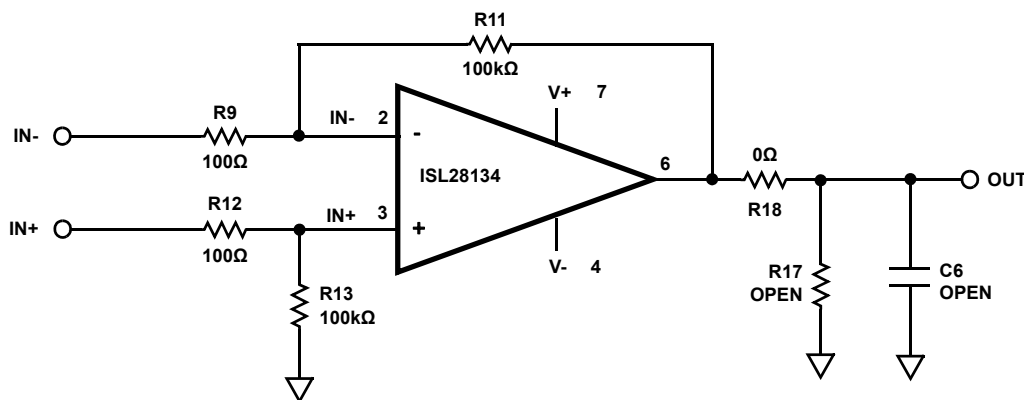

FIGURE 2. BASIC DIFFERENTIAL AMPLIFIER CONFIGURATION

## Amplifier Configuration (Figure 3)

The schematic of the op amp input stage with the components supplied is shown in Figure 3, with a closed loop gain of 1,000V/V. The differential amplifier implements a high impedance differential input. The amplifier gain equation is expressed in Equation 1 as:

$$V_{OUT} = (V_{IN+} - V_{IN-}) \cdot (R11/R9) \quad (EQ. 1)$$

For single-ended inputs the amplifier can be configured as an inverting gain  $G = -1,000V/V$  by grounding the IN+ input, or as a non-inverting amplifier with  $G = +1,001V/V$  by grounding the IN- input. The non-inverting gain is strongly dependent on any resistance from IN- to GND. For good gain accuracy, a 0Ω resistor should be installed on the empty R1 pad.

## User-Selectable Options

(Figures 3 and 4)

Component pads are included to enable a variety of user-selectable circuits to be added to the amplifier inputs, outputs and the amplifier feedback loops.

The inverting and non-inverting inputs have additional resistor placements for adding input attenuation or to establish input DC offset through the VREF pin. To add a reference input without

scaling it by the gain of the amplifier to the output, the circuit needs to be modified slightly. R13 and R15 form a voltage divider to the amplifier IN+ terminal and is chosen to give the inverse of the feedback gain. In this configuration,  $R13 = R9$  and  $R15 = R11$  to scale the reference input by 1,000 while the feedback gain of the amplifier drives the input DC offset to the output in a 1:1 ratio. The non-inverting input signal will need to be AC-coupled into the amplifier.

The op-amp output (Figure 4) also has additional resistor and capacitor placements for filtering and loading.

NOTE: Operational amplifiers are sensitive to output capacitance and may oscillate. In the event of oscillation, reduce output capacitance by using shorter cables, or add a resistor in series with the output.

## High Gain Low Noise Amplifier

The high performance of the ISL28134 allow it to be configured as a very high gain amplifier with excellent DC and noise performance. The low offset voltage and low noise combined with a high gain is ideal for amplifying very small precision signals accurately for sensor applications. The eval board has been specifically configured for a gain of 1,000V/V to highlight these features of the ISL28134.

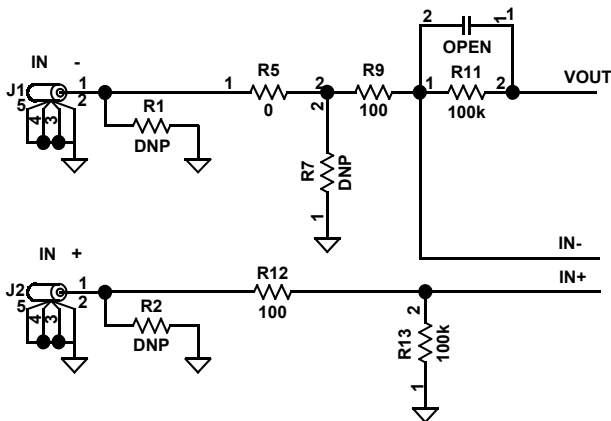

FIGURE 3. INPUT STAGE

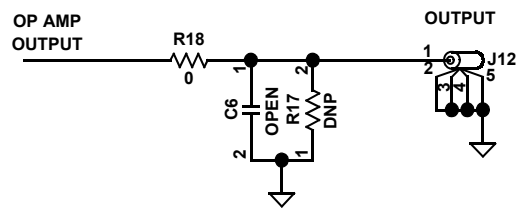
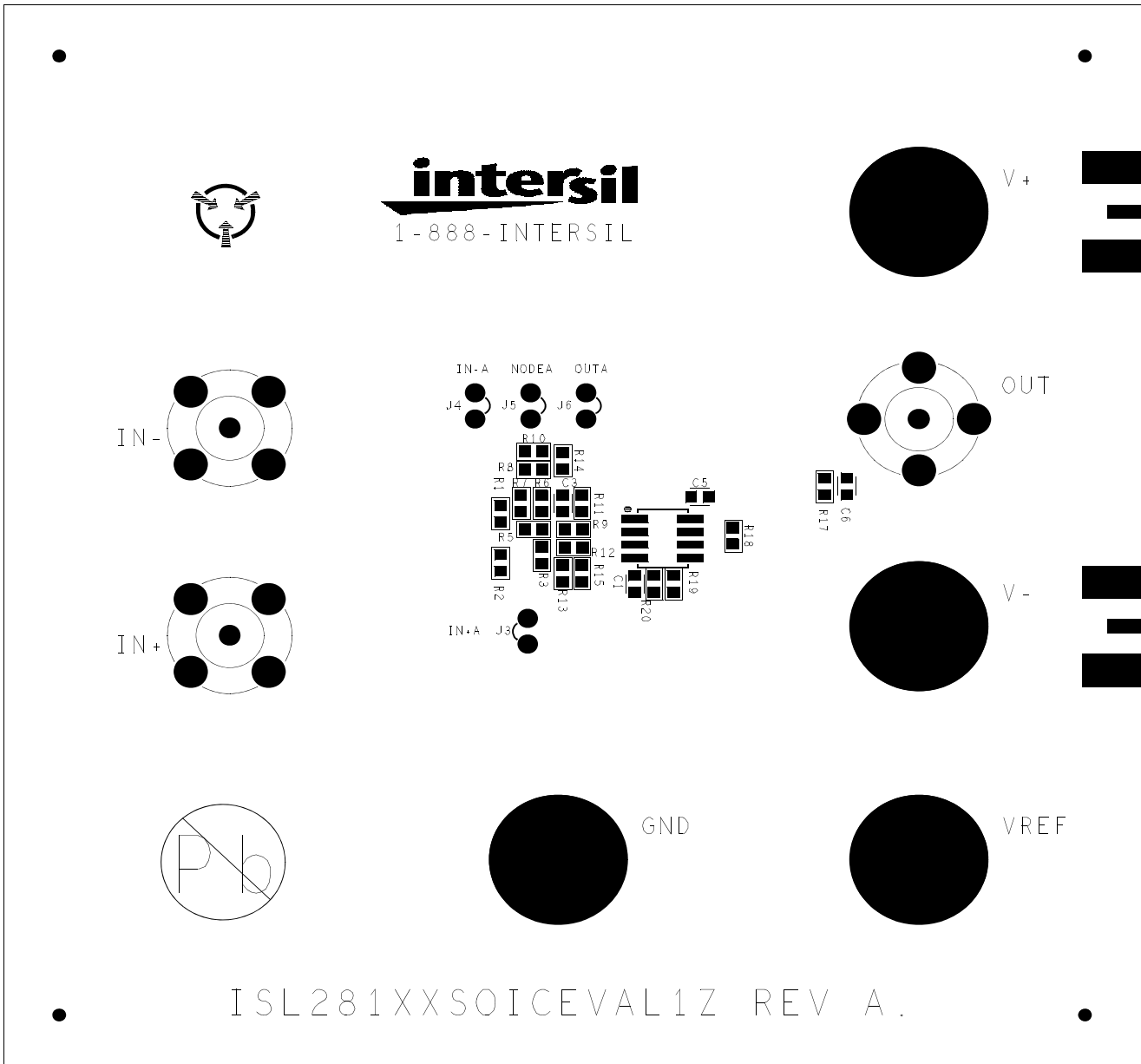

FIGURE 4. OUTPUT STAGE

TABLE 1. ISL28233SOICEVAL1Z COMPONENTS PARTS LIST

DEVICE #	DESCRIPTION	COMMENTS
U1	ISL28134IBZ	SOIC 8 Ld Package
R11	100kΩ, 603, 0.125W, SMD Resistor	Feedback Gain
C3	DNP 603 SMD Capacitor	Feedback Filtering
R9, R12	100Ω, 603, 0.125W SMD Capacitor	Gain Set Resistors
R17	DNP, 603, SMD Resistor	Output Loading
C6	DNP 603 SMD Capacitor	Output Filtering
R1, R2, R3, R4, R6, R7, R8, R10, R14, R15, R16, R19, R20	DNP 603 SMD Resistor	
C1, C2, C4, C5	Power Supply Decoupling	C1 = C5 = 0.01μF; C2 = C4 = 4.7μF
D1, D2	Reverse Polarity Protection Diode	

ISL28134SOICEVAL1Z Top View



Intersil Corporation reserves the right to make changes in circuit design, software and/or specifications at any time without notice. Accordingly, the reader is cautioned to verify that the Application Note or Technical Brief is current before proceeding.

For information regarding Intersil Corporation and its products, see [www.intersil.com](http://www.intersil.com)

# ISL28134SOICEVAL1Z Schematic Diagram

