



Chipsmall Limited consists of a professional team with an average of over 10 year of expertise in the distribution of electronic components. Based in Hongkong, we have already established firm and mutual-benefit business relationships with customers from,Europe,America and south Asia,supplying obsolete and hard-to-find components to meet their specific needs.

With the principle of “Quality Parts,Customers Priority,Honest Operation,and Considerate Service”,our business mainly focus on the distribution of electronic components. Line cards we deal with include Microchip,ALPS,ROHM,Xilinx,Pulse,ON,Everlight and Freescale. Main products comprise IC,Modules,Potentiometer,IC Socket,Relay,Connector.Our parts cover such applications as commercial,industrial, and automotives areas.

We are looking forward to setting up business relationship with you and hope to provide you with the best service and solution. Let us make a better world for our industry!



Contact us

Tel: +86-755-8981 8866 Fax: +86-755-8427 6832

Email & Skype: info@chipsmall.com Web: www.chipsmall.com

Address: A1208, Overseas Decoration Building, #122 Zhenhua RD., Futian, Shenzhen, China



ISL28194EVAL1Z, ISL28195EVAL1Z Evaluation Board User's Guide

Introduction

The ISL28194EVAL1Z, ISL28195EVAL1Z evaluation board is a design platform containing all the circuitry needed to characterize critical performance parameters of the ISL28194 and ISL28195 operational amplifiers, using a variety of user defined test circuits.

The ISL28194 and ISL28195 micro-power operational amplifiers feature ultra-low power consumption, rail-to-rail input and output drive capability, and are designed to operate with two 1.5V Alkaline batteries.

Ordering Information

- ISL28194EVAL1Z
- ISL28195EVAL1Z

Reference Documents

- ISL28194, ISL28195 Data Sheet, FN6236

Evaluation Board Key Features

The ISL28194EVAL1Z, ISL28195EVAL1Z is designed to enable the IC to operate from a single supply, +1.8VDC to +5.5VDC or from split supplies, ±0.9VDC to ±2.75V. The board is configured for a single op amp connected for differential input with a closed loop gain of 10. It also contains a single external reference voltage (VREF) pin and provisions for a user-selectable voltage divider (filter are included).

Power Supplies (Figure 1)

External power connections are made through the V+, V- and Ground connections on the evaluation board. For single supply operation, the V- and Ground pins are tied together to the power supply negative terminal. For split

supplies V+ and V- terminals connect to their respective power supply terminals. De-coupling capacitors C₁ and C₂ connect to ground through R₁ and R₂₁ 0Ω resistors. Resistors R₂₀ and R₂₄ are 0Ω but can be changed by the user to provide additional power supply filtering, or to reduce the voltage rate-of-rise to less than ±1V/μs. Two additional capacitors, C₃ and C₄ are connected close to the part to filter out high frequency noise. Anti-reverse diodes D₁ and D₂ protect the circuit in the case of accidental polarity reversal.

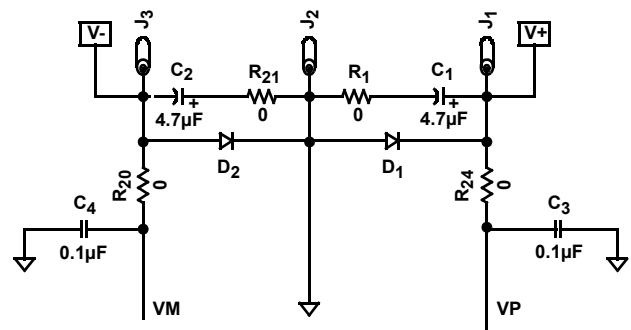

FIGURE 1. POWER SUPPLY CIRCUIT

Amplifier Configuration (Figure 2)

The schematic of the op amp with the components supplied is shown in Figure 2.

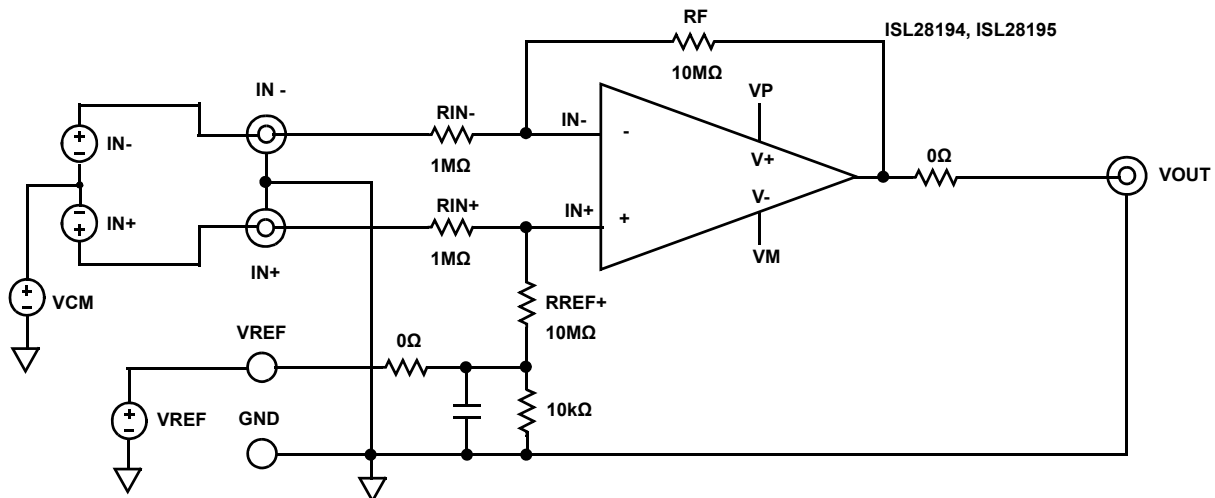

FIGURE 2. BASIC AMPLIFIER CONFIGURATION

User-Selectable Options (Figures 3 and 4)

Component pads are included to enable a variety of user-selectable circuits to be added to the amplifier inputs, the VREF input, outputs and the amplifier feedback loops.

A voltage divider and filter option (Figure 3) can be added to establish a power supply-tracking common

mode reference at the VREF input. The inverting and non-inverting inputs have additional resistor placements for adding input attenuation, or to establish input DC offsets through the VREF pin.

The output (Figure 4) has additional resistor and capacitor placements for loading.

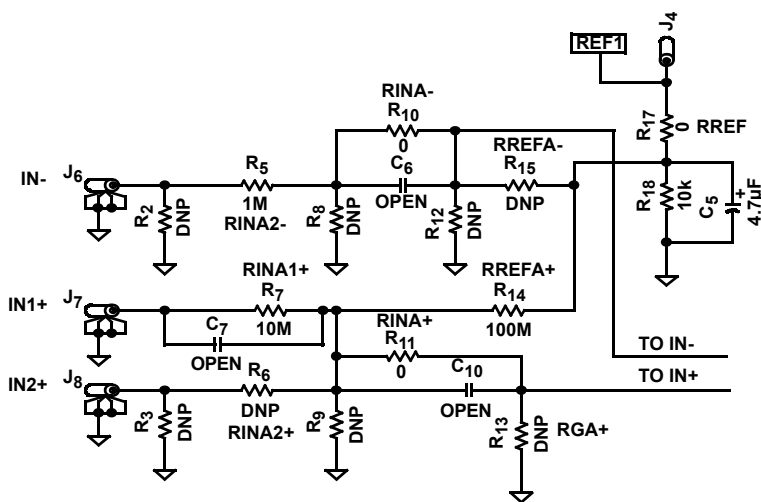

FIGURE 3. INPUT STAGE

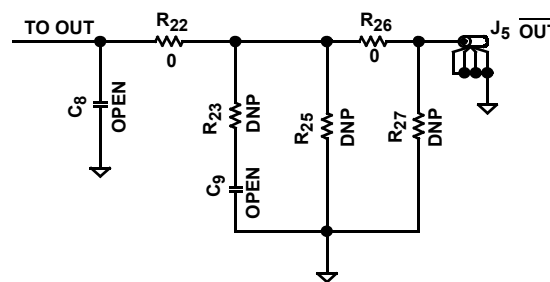
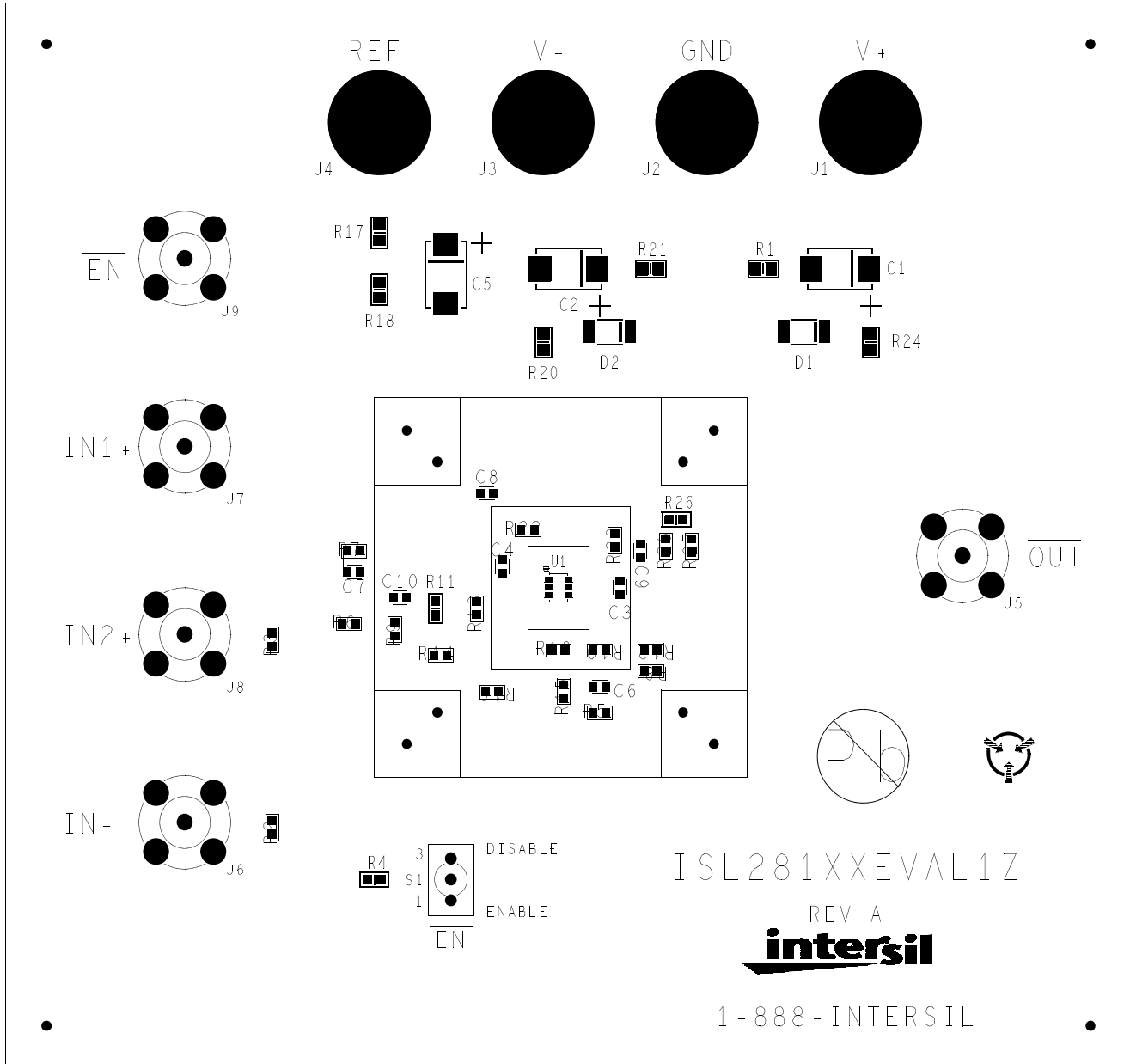

FIGURE 4. OUTPUT STAGE

ISL28194EVAL1Z, ISL28195EVAL1Z Components Parts List

DEVICE NUMBER	DESCRIPTION	COMMENTS
C1, C2, C5	CAP-TANTALUM, SMD, D, 4.7µF, 50V, 10%, LOW ESR, ROHS	Power supply decoupling
C3, C4	CAP, SMD, 0603, 0.1µF, 25V, 10%, X7R, ROHS	Power supply decoupling
C6 to C10	CAP, SMD, 0603, DNP-PLACE HOLDER, ROHS	User-selectable capacitors - not populated
D1, D2	DIODE-RECTIFIER, SMD, SOD-123, 2P, 40V, 0.5A, ROHS	Reverse power protection
U1 (ISL28194EVAL1Z)	ISL28194FHZ-T7, IC-RAIL-TO-RAIL OP AMP, SOT-23, ROHS	
U1 (ISL28195EVAL1Z)	ISL28195FHZ-T7, IC-RAIL-TO-RAIL OP AMP, SOT-23, ROHS	
R2, R3, R6, R8, R9, R12, R13, R15, R23, R25, R27	RESISTOR, SMD, 0603, 0.1%, MF, DNP-PLACE HOLDER	User-selectable resistors - not populated
R1, R5, R11, R17, R20, R21, R22, R24, R26	RES, SMD, 0603, 0Ω, 1/10W, TF, ROHS	0Ω user-selectable resistors
R4, R18	RES, SMD, 0603, 10k, 1/10W, 1%, TF, ROHS	Gain and other user-selectable resistors
R16	RES, SMD, 0603, 100k, 1/10W, 1%, TF, ROHS	Gain resistors
R7, R10	RES, SMD, 0603, 1M, 1/10W, 1%, TF, ROHS	Gain and other user-selectable resistors
R14, R19	RES, SMD, 0603, 10M, 1/10W, 1%, TF, ROHS	Gain resistors

ISL28194EVAL1Z, ISL28195EVAL1Z Top View



Intersil Corporation reserves the right to make changes in circuit design, software and/or specifications at any time without notice. Accordingly, the reader is cautioned to verify that the Application Note or Technical Brief is current before proceeding.

For information regarding Intersil Corporation and its products, see www.intersil.com

ISL28194EVAL1Z, ISL28195EVAL1Z Schematic Diagram

