



Chipsmall Limited consists of a professional team with an average of over 10 year of expertise in the distribution of electronic components. Based in Hongkong, we have already established firm and mutual-benefit business relationships with customers from,Europe,America and south Asia,supplying obsolete and hard-to-find components to meet their specific needs.

With the principle of “Quality Parts,Customers Priority,Honest Operation,and Considerate Service”,our business mainly focus on the distribution of electronic components. Line cards we deal with include Microchip,ALPS,ROHM,Xilinx,Pulse,ON,Everlight and Freescale. Main products comprise IC,Modules,Potentiometer,IC Socket,Relay,Connector.Our parts cover such applications as commercial,industrial, and automotives areas.

We are looking forward to setting up business relationship with you and hope to provide you with the best service and solution. Let us make a better world for our industry!



Contact us

Tel: +86-755-8981 8866 Fax: +86-755-8427 6832

Email & Skype: info@chipsmall.com Web: www.chipsmall.com

Address: A1208, Overseas Decoration Building, #122 Zhenhua RD., Futian, Shenzhen, China



ISL28218SOICEVAL1Z Evaluation Board User's Guide

Introduction

The ISL28218SOICEVAL1Z evaluation board is designed to evaluate the performance of the ISL28218 40V Precision Low Power Operational Amplifier. The ISL28218 is a single supply rail-to-rail output, dual amplifier with ground sensing inputs that allow the common mode input voltage to swing 0.5V below the V- rail. The ISL28218 can operate from a single or dual supply with a 3V to 40V supply range. The ISL28218 features very low power, low offset voltage and low temperature drift making them ideal for applications for precision medical and instrumentation, current sensing and power supply and industrial process controls.

Reference Documents

- ISL28218 Datasheet, [FN7532](#)

Evaluation Board Key Features

- Single Supply Operation: +3V to +40V
- Dual Supply Operation: $\pm 1.5V$ to $\pm 20V$
- Singled-Ended or Differential Input Operation
- External VREF input
- Banana Jack Connectors for Power Supply and VREF Inputs
- BNC Connectors for Op Amp Input and Output Terminals
- Convenient PCB pads for Op Amp Input/Output impedance loading.

Power Supplies (Figure 1)

External power connections are made through the V+, V-, VREF, and GND connections on the evaluation board. The circuit can operate from a single supply or from dual supplies. For single supply operation, the V- and GND pins are tied together to the negative or ground reference of the power supply. For split supplies, V+ and V- terminals connect to their respective supply terminals. De-coupling capacitors C2 and C4 provide low-frequency power-supply filtering, while additional capacitors, C3 and C5, which are connected close to the part, filter out high frequency noise. Anti-reverse diode D1 (optional) protects the circuit in the momentary case of accidentally reversing the power supplies to the evaluation board. The VREF pin can be connected to ground to establish a ground referenced input for split supply operation, or can be externally set to any reference level for single supply operation.

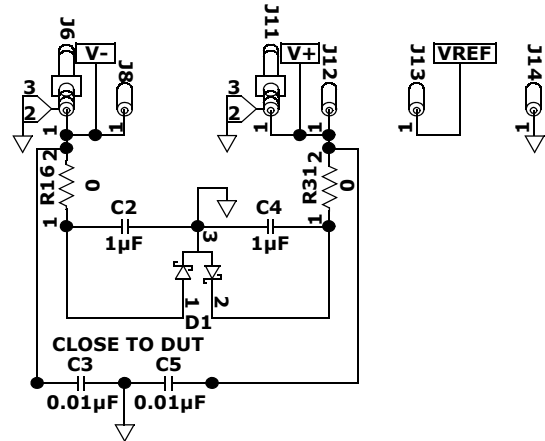

FIGURE 1. POWER SUPPLY CIRCUIT

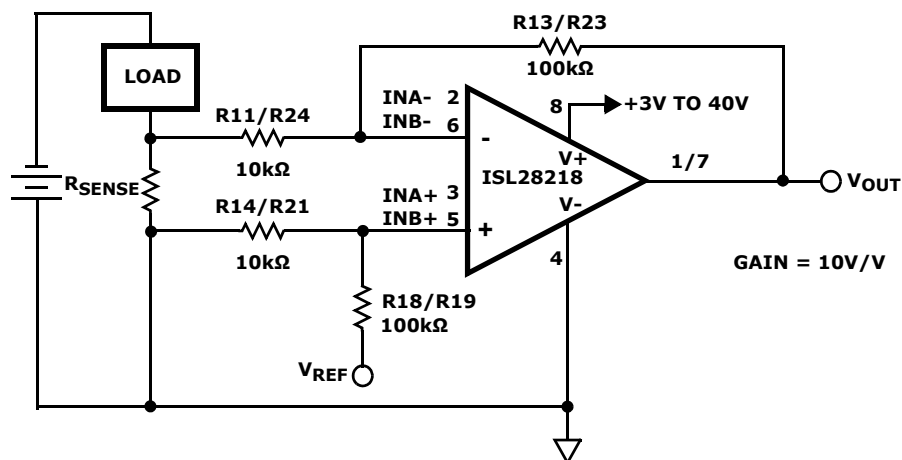

FIGURE 2. CURRENT SENSE AMPLIFIER

Amplifier Configuration (Figure 3)

The schematic of the op amp input stage with the components supplied is shown in Figure 3, with a closed loop gain of 10V/V. The differential amplifier gain is expressed in Equation 1:

$$V_{OUT} = (V_{IN+} - V_{IN-}) \cdot (R_F/R_{IN}) + V_{REF} \quad (EQ. 1)$$

For single-ended input with an inverting gain $G = -10V/V$, the IN+ input is grounded and the signal is supplied to the IN- input. VREF can be connected to a reference voltage between the V+ and V- supply rails. For non-inverting operation with $G = 11V/V$, the IN- input is grounded and the signal is supplied to the IN+ input. The non-inverting gain is strongly dependent on any resistance from IN- to GND. For good gain accuracy, a 0Ω resistor should be installed on the empty R5 pad.

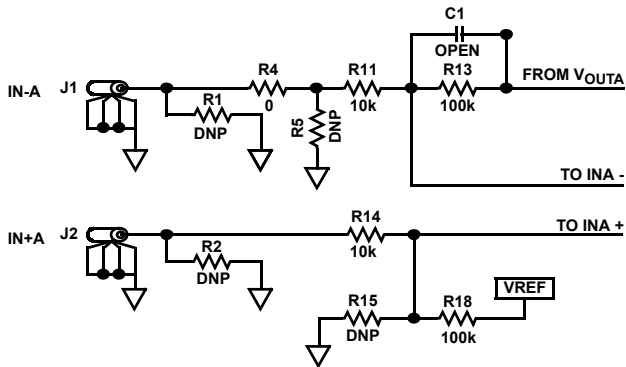

FIGURE 3. INPUT STAGE

User-selectable Options (Figures 3 and 4)

Component pads are included to enable a variety of user-selectable circuits to be added to the amplifier inputs, the VREF input, outputs and the amplifier feedback loops.

A voltage divider (Figure 3, R18 and R15) can be added to establish a power supply-tracking common mode reference using the VREF input. The inverting and non-inverting inputs have additional resistor placements for adding input attenuation, or to establish input DC offsets through the VREF pin.

The output (Figure 4) also has additional resistor and capacitor placements for filtering and loading.

NOTE: Operational amplifiers are sensitive to output capacitance and may oscillate. In the event of oscillation, reduce output capacitance by using shorter cables, or add a resistor in series with the output.

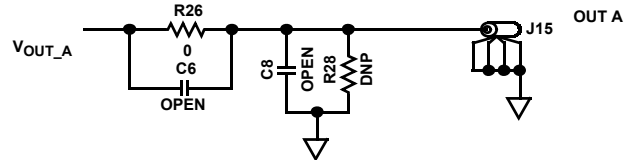
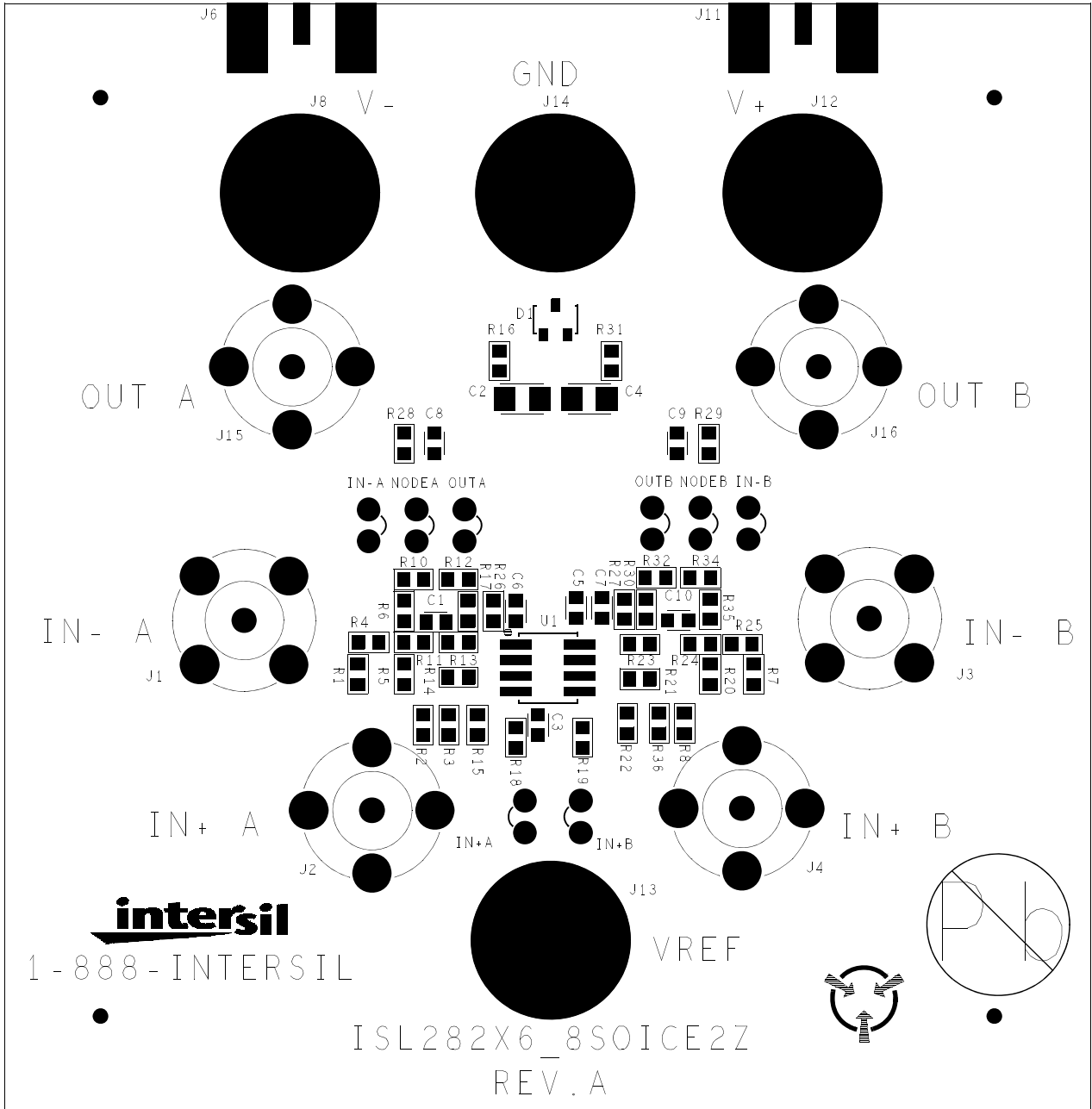

FIGURE 4. OUTPUT STAGE

TABLE 1. ISL28218SOICEVAL1Z COMPONENTS PARTS LIST

DEVICE #	DESCRIPTION	COMMENTS
C2, C4	CAP, SMD, 1206, 1μF, 50V, 10%, X7R, ROHS	Power Supply Decoupling
C3, C5	CAP, SMD, 0603, 0.01μF, 50V, 10%, X7R, ROHS	Power Supply Decoupling
C1, C6, C7, C8, C9, C10	CAP, SMD, 0603, DNP-PLACE HOLDER, ROHS	User selectable capacitors - not populated
R11, R14, R21, R24	RESISTOR, SMD, 0603, 10kΩ, 1%, 1/16W, ROHS	Gain Setting Resistor
R13, R23	RESISTOR, SMD, 0603, 100kΩ, 1%, 1/16W, ROHS	Gain Setting Feedback Resistor
R1-R3, R5-R8, R10, R12, R15, R17, R20, R22, R28-R30, R32, R34-R36	RESISTOR, SMD, 0603, DNP-PLACE HOLDER, ROHS	User selectable resistors - not populated
D1	40V DUAL SERIES SCHOTTKY BARRIER DIODE	Reverse Power Protection
U1 (ISL28218FBZ)	ISL28218FBZ, IC 40V RAIL-TO-RAIL OP AMP, SOIC, ROHS	

ISL28218SOICEVAL1Z Top View



Intersil Corporation reserves the right to make changes in circuit design, software and/or specifications at any time without notice. Accordingly, the reader is cautioned to verify that the Application Note or Technical Brief is current before proceeding.

For information regarding Intersil Corporation and its products, see www.intersil.com

ISL28218SOICEVAL1Z Schematic Diagram

