



Chipsmall Limited consists of a professional team with an average of over 10 year of expertise in the distribution of electronic components. Based in Hongkong, we have already established firm and mutual-benefit business relationships with customers from,Europe,America and south Asia,supplying obsolete and hard-to-find components to meet their specific needs.

With the principle of "Quality Parts,Customers Priority,Honest Operation,and Considerate Service",our business mainly focus on the distribution of electronic components. Line cards we deal with include Microchip,ALPS,ROHM,Xilinx,Pulse,ON,Everlight and Freescale. Main products comprise IC,Modules,Potentiometer,IC Socket,Relay,Connector.Our parts cover such applications as commercial,industrial, and automotives areas.

We are looking forward to setting up business relationship with you and hope to provide you with the best service and solution. Let us make a better world for our industry!



Contact us

Tel: +86-755-8981 8866 Fax: +86-755-8427 6832

Email & Skype: info@chipsmall.com Web: www.chipsmall.com

Address: A1208, Overseas Decoration Building, #122 Zhenhua RD., Futian, Shenzhen, China



Introduction

The ISL282x6EVAL1Z evaluation board is a design platform containing all the circuitry needed to characterize critical performance parameters of the ISL282x6 operational amplifiers in both MSOP-8 and SOIC-8 packages, using a variety of user defined test circuits.

The ISL28236 and ISL28246 high-speed operational amplifiers feature low power consumption, while ISL28256 and ISL28266 operational amplifiers feature ultra-low power consumption. All op amps have rail-to-rail output drive capability and are designed to operate with a single lithium cell or two Ni_Cd batteries.

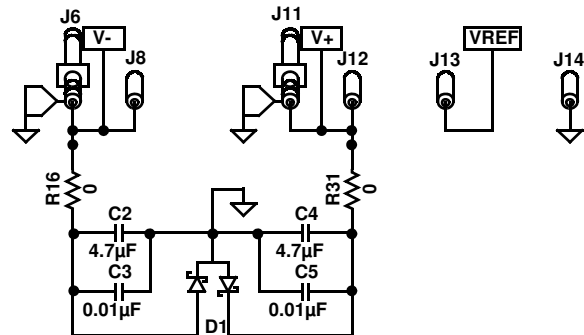

FIGURE 1. POWER SUPPLY CIRCUIT

Reference Documents

- ISL28236 Data Sheet
- ISL28246 Data Sheet
- ISL28256 Data Sheet
- ISL28266 Data Sheet

Evaluation Board Key Features

The ISL282x6EVAL1Z is designed to enable the IC to operate from a single supply, +2.4VDC to +5.5VDC or from split supplies, ±1.2VDC to ±2.75V. The board is configured for a dual op amp connected for differential input with a closed loop gain of 10. A single external reference voltage (VREF) pin and provisions for a user-selectable voltage divider - filter are included.

Power Supplies (Figure 1)

External power connections are made through the +V, -V, VREF and Ground connections on the evaluation board.

User selectable SMA edge connectors are also provided for +V and -V. For single supply operation, the -V and Ground pins are tied together to the power supply negative terminal. For split supplies, +V and -V terminals connect to their respective power supply terminals. De-coupling capacitors C₂ and C₄ connect to their respective supplies through R₁₆ and R₃₁ 0Ω resistors. These resistors are 0Ω but can be changed by the user to provide additional power supply filtering, or to reduce the voltage rate-of-rise to less than ±1V/μs. Two additional capacitors, C₃ and C₅ are connected close to the part to filter out high frequency noise. Anti-reverse diode D₁ protects the circuit in the case of accidental polarity reversal.

Amplifier Configuration (Figure 2)

The schematic of 1/2 of the op amp with the components supplied is shown in Figure 2. The circuit implements a differential input amp with a closed loop gain of 10. The circuit can operate from a single supply or from dual supplies. The VREF pin must be connected to ground to

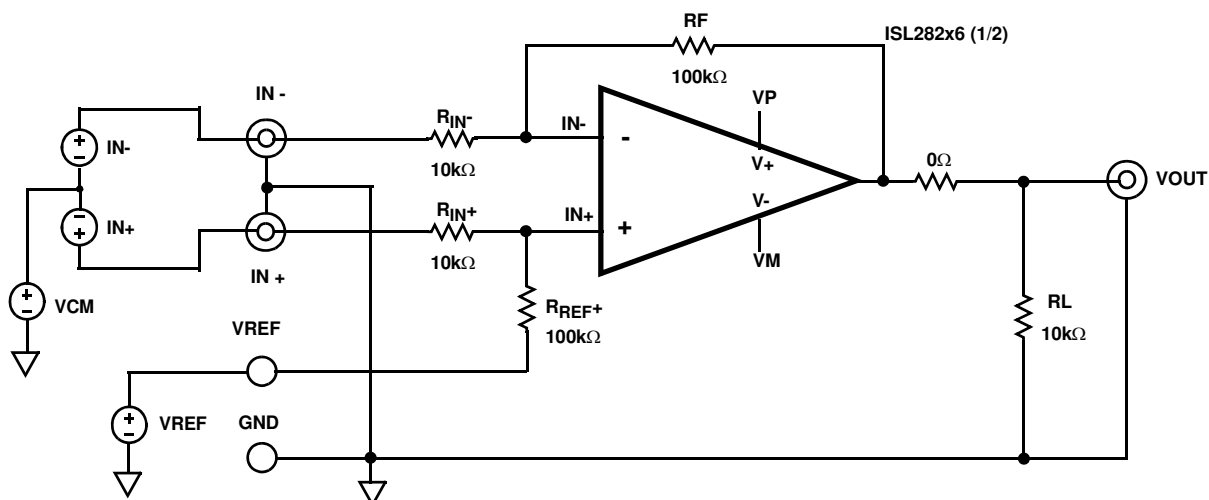

FIGURE 2. BASIC AMPLIFIER CONFIGURATION

establish a ground referenced input for dual supply operation, or can be externally set to any reference level for single supply operation. VREF should not be left floating.

User-selectable Options (Figures 3 and 4)

Component pads are included to enable a variety of user-selectable circuits to be added to the amplifier VREF, inputs, outputs, and the amplifier feedback loops. The inputs (Figure 3) have additional resistor and capacitor, and jumper placements for loading and/or measurement of frequency sensitive parameters.

The outputs (see Figure 4) have a 10kΩ load resistor to ground and have additional resistor and capacitor placements for loading.

Note: Operational amplifiers are sensitive to output capacitance and may oscillate. In the event of oscillation, reduce output capacitance by using shorter cables or add a resistor in series with the output.

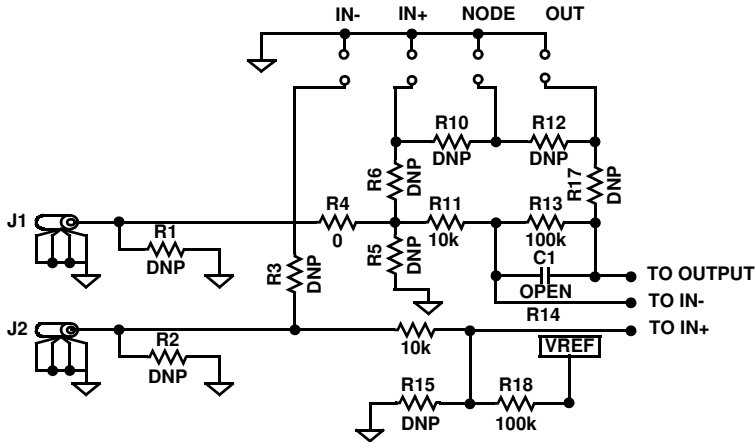

FIGURE 3. INPUT STAGE (1/2)

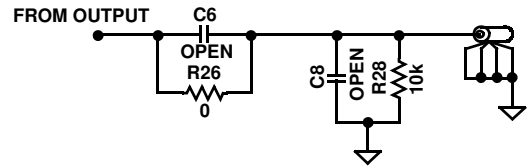

FIGURE 4. OUTPUT STAGE (1/2)

Application Note 1420

ISL282x6EVAL1Z Components Parts List

DEVICE #	DESCRIPTION	COMMENTS
C2, C4	CAP-TANTALUM, SMD, D, 4.7 μ F, 50V, 10%, LOW ESR, ROHS	Power supply decoupling
C3, C5	CAP, SMD, 0603, 0.1 μ F, 25V, 10%, X7R, ROHS	Power supply decoupling
C1, C6 thru C10	CAP, SMD, 0603, DNP-PLACE HOLDER, ROHS	User-selectable capacitors - not populated
D1	DIODE-SCHOTTKY BARRIER, SMD, SOT-23, 3P, 40V, ROHS	Reverse power protection
U1 (ISL28236FUZ)	IC-5 MHz RRIO OP AMP, 8P, MSOP, ROHS	
U1 (ISL28236FBZ)	IC-5 MHz RRIO OP AMP, 8P, SOIC, ROHS	
U1 (ISL28246FUZ)	IC-5 MHz RRIO OP AMP, 8P, MSOP, ROHS	
U1 (ISL28246FBZ)	IC-5 MHz RRIO OP AMP, 8P, SOIC, ROHS	
U1 (ISL28256FUZ)	IC-39 μ A RRIO OP AMP, 8P, MSOP, ROHS	
U1 (ISL28256FBZ)	IC-39 μ A RRIO OP AMP, 8P, SOIC, ROHS	
U1 (ISL28266FUZ)	IC-39 μ A RRIO OP AMP, 8P, MSOP, ROHS	
U1 (ISL28266FBZ)	IC-39 μ A RRIO OP AMP, 8P, SOIC, ROHS	
R30, R32, R34 thru R36	RESISTOR, SMD, 0603, 0.1%, MF, DNP-PLACE HOLDER	User selectable resistors - not populated
R4, R16, R25 thru R27, R31	RES, SMD, 0603, 0 Ω , 1/10W,TF, ROHS	0 Ω user selectable resistors
R11, R14, R21, R24, R28, R29	RES, SMD, 0603, 10k, 1/10W, 1%, TF, ROHS	Gain and other user selectable resistors
R13, R18, R19, R23	RES, SMD, 0603, 100k, 1/10W, 1%, TF, ROHS	Gain resistors

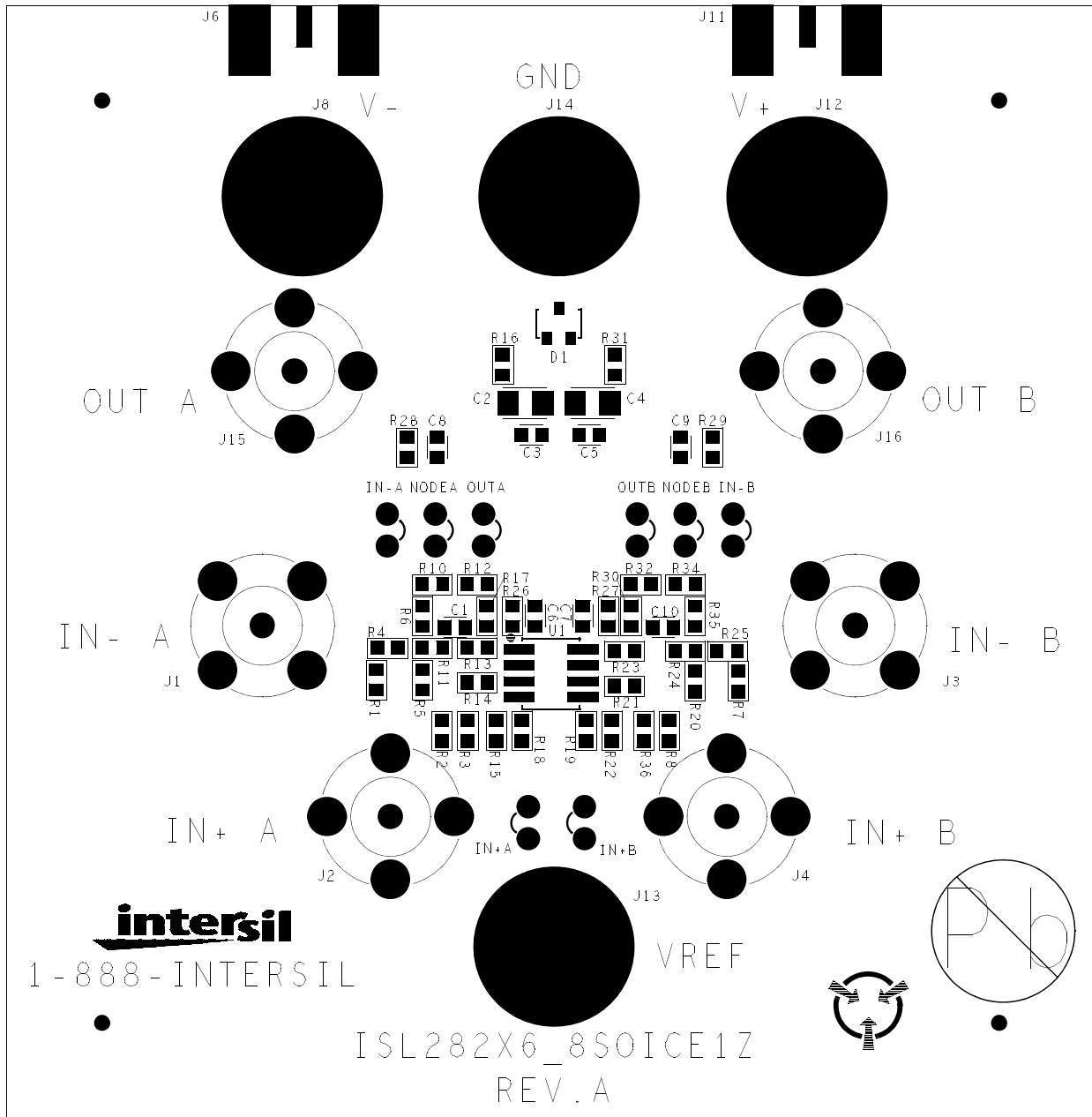
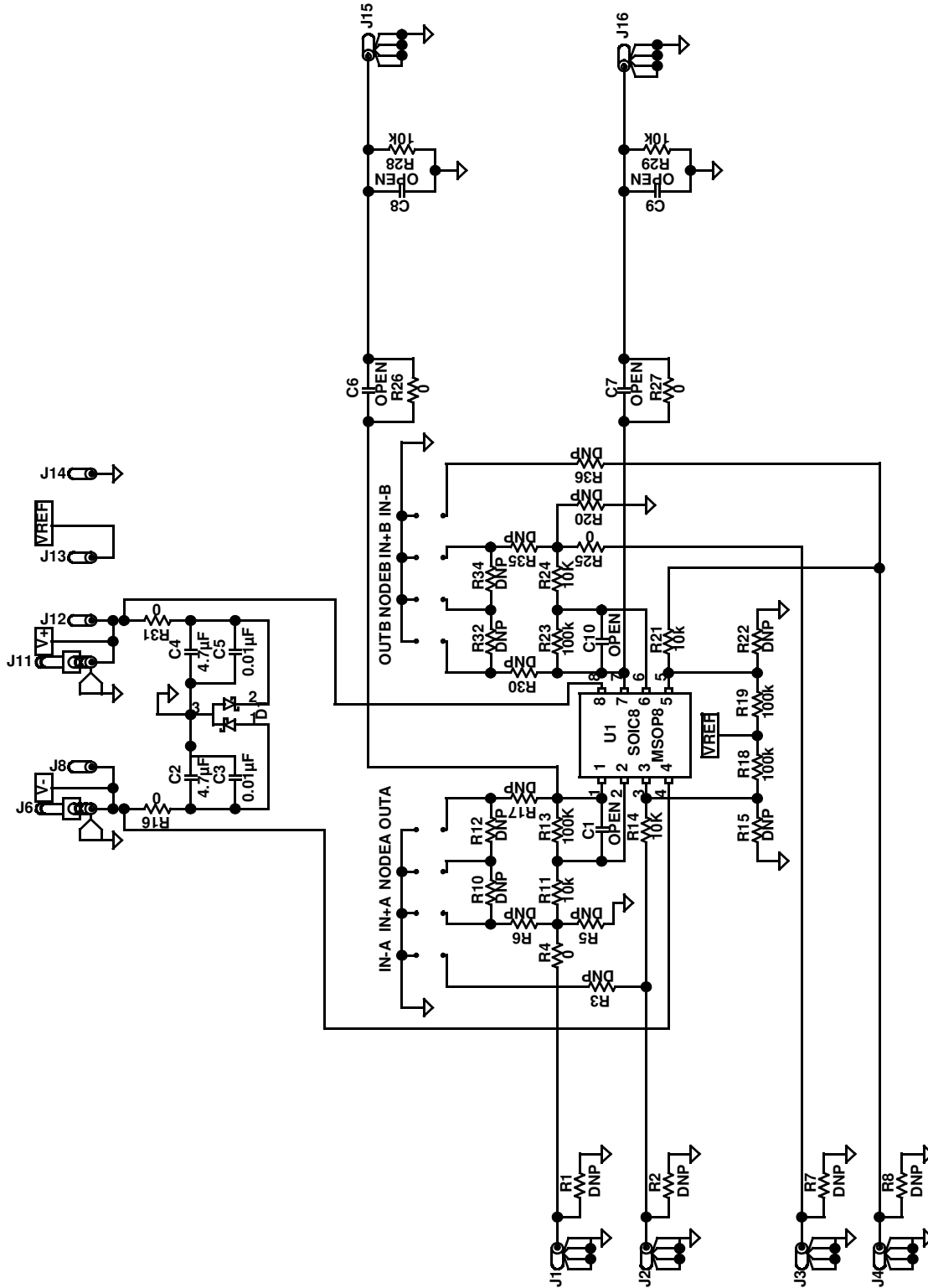

FIGURE 5. ISL282x6EVAL1Z TOP VIEW (SOIC SHOWN)

ISL282x6EVAL1Z Schematic Diagram



Intersil Corporation reserves the right to make changes in circuit design, software and/or specifications at any time without notice. Accordingly, the reader is cautioned to verify that the Application Note or Technical Brief is current before proceeding.

For information regarding Intersil Corporation and its products, see www.intersil.com