



Chipsmall Limited consists of a professional team with an average of over 10 year of expertise in the distribution of electronic components. Based in Hongkong, we have already established firm and mutual-benefit business relationships with customers from,Europe,America and south Asia,supplying obsolete and hard-to-find components to meet their specific needs.

With the principle of “Quality Parts,Customers Priority,Honest Operation,and Considerate Service”,our business mainly focus on the distribution of electronic components. Line cards we deal with include Microchip,ALPS,ROHM,Xilinx,Pulse,ON,Everlight and Freescale. Main products comprise IC,Modules,Potentiometer,IC Socket,Relay,Connector.Our parts cover such applications as commercial,industrial, and automotives areas.

We are looking forward to setting up business relationship with you and hope to provide you with the best service and solution. Let us make a better world for our industry!



Contact us

Tel: +86-755-8981 8866 Fax: +86-755-8427 6832

Email & Skype: info@chipsmall.com Web: www.chipsmall.com

Address: A1208, Overseas Decoration Building, #122 Zhenhua RD., Futian, Shenzhen, China



Introduction

The ISL2828xEVAL1Z evaluation board is a design platform containing all the circuitry needed to characterize critical performance parameters of the ISL28286 and ISL28288 dual operational amplifiers, using a variety of user defined test circuits.

The ISL2828x amplifiers feature low noise, low distortion, and rail-to-rail output drive capability. They are designed to operate with single and dual supplies from +5VDC (± 2.5 VDC) down to +2.4VDC (± 1.2 VDC).

Reference Documents

- ISL28286 Data Sheet, FN6312
- ISL28288 Data Sheet, FN6339

Evaluation Board Key Features

The ISL2828xEVAL1Z is designed to enable the IC to operate from a single supply (+2.4VDC to +5VDC), or from split supplies (± 1.2 VDC to ± 2.5 V). The board is configured for 2 independent op amps connected for differential input with a closed loop gain of 10. A single external reference voltage (VREF) pin and provisions for a user-selectable voltage divider (filter is included).

Power Supplies (Figure 1)

External power connections are made through the V+, V- and Ground connections on the evaluation board. For single supply operation, the V- and Ground pins are tied together to the power supply negative terminal. For split supplies V+ and V- terminals connect to their respective power supply terminals. De-coupling capacitors C₁₂, C₁₇, connect to ground through R₁, R₄₆, 0 Ω resistors. Resistors R₄₀ and

R₄₉ are 0 Ω but can be changed by the user to provide additional power supply filtering, or to reduce the voltage rate-of-rise to less than ± 1 V/ μ s. Two additional capacitors, C₁₀ and C₁₈, are connected close to the part to filter out high frequency noise. Anti-reverse diodes D₁, D₂ and zener diode D₃ protect the circuit in the case of accidental polarity reversal.

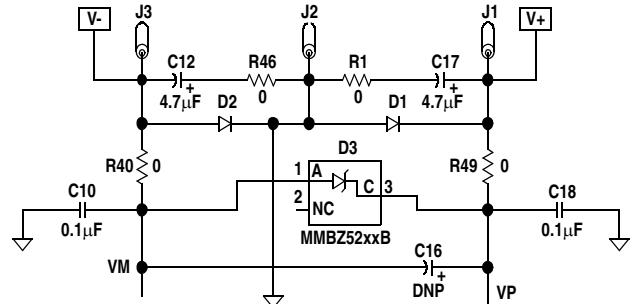

FIGURE 1. POWER SUPPLY CIRCUIT

Amplifier Configuration (Figure 2)

The schematic of each of the 2 op amps with the components supplied is shown in Figure 2. The circuit implements a differential input amp with a closed loop gain of 10. The circuit can operate from a single 2.4VDC to +5VDC supply, or from dual supplies from ± 1.2 VDC to ± 2.5 VDC. The VREF pin can be connected to ground to establish a ground referenced input for split supply operation, or can be externally set to any reference level for single supply operation.

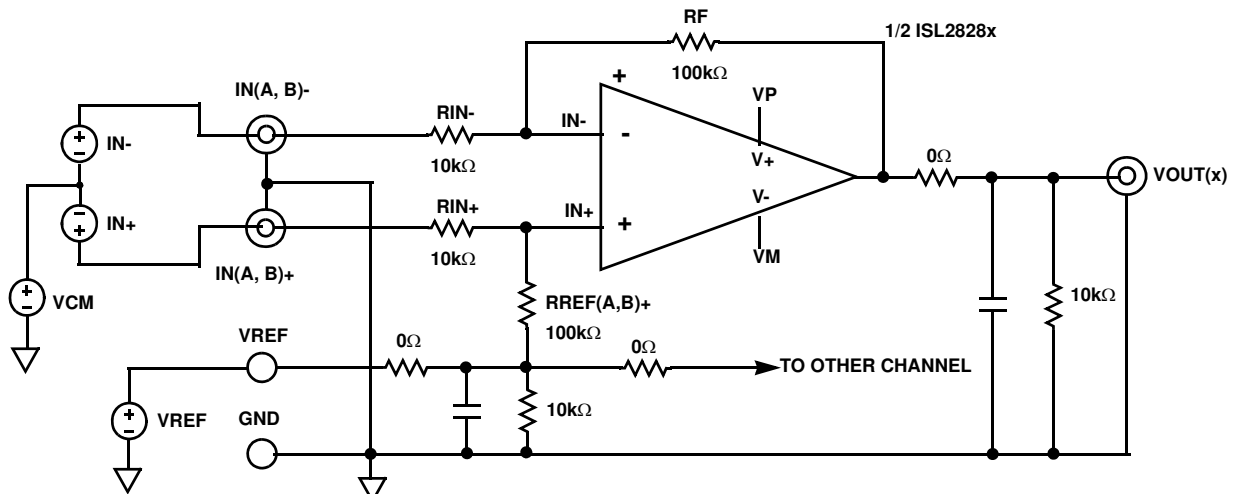

FIGURE 2. BASIC AMPLIFIER CONFIGURATION

User-Selectable Options (Figures 3 to 5)

Component pads are included to enable a variety of user-selectable circuits to be added to the amplifier inputs, the VREF input, outputs and the amplifier feedback loops. The outputs (Figure 3) have additional resistor and capacitor placements for loading.

A voltage divider and filter option (Figure 4) can be added to establish a power supply-tracking common mode reference at the VREF input. The inverting and non-inverting inputs have additional resistor placements for adding input attenuation, or to establish input DC offsets through the VREF pin.

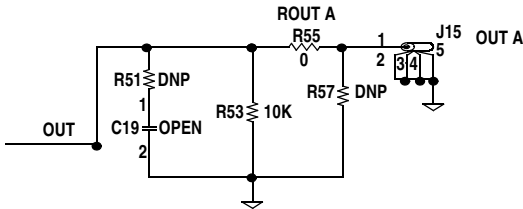

FIGURE 3. 1/2 OUTPUT STAGE

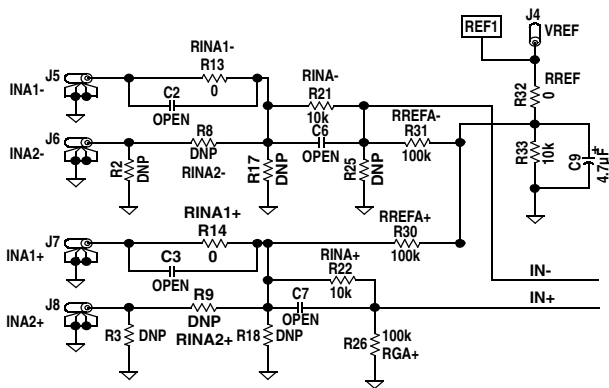

FIGURE 4. 1/2 INPUT STAGE

In the standard configuration (Figure 5), R₄₁ and R₄₅ are RF feedback resistors for the two independent amplifiers, set for AV = 10. Resistors R₄₇ and R₄₈ connect the DUT output to the output circuit (Figure 3). The additional unpopulated components, R₃₄ to R₃₉, R₄₂ to R₄₄, C₁₀, C₁₁, C₁₃ to C₁₅ and C₁₈ allow the user to configure the board for a variety of other applications such as cascaded gain stages, active feedback loops, etc.

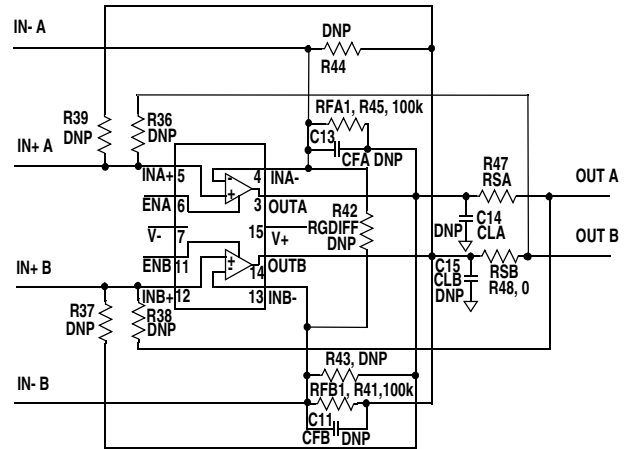
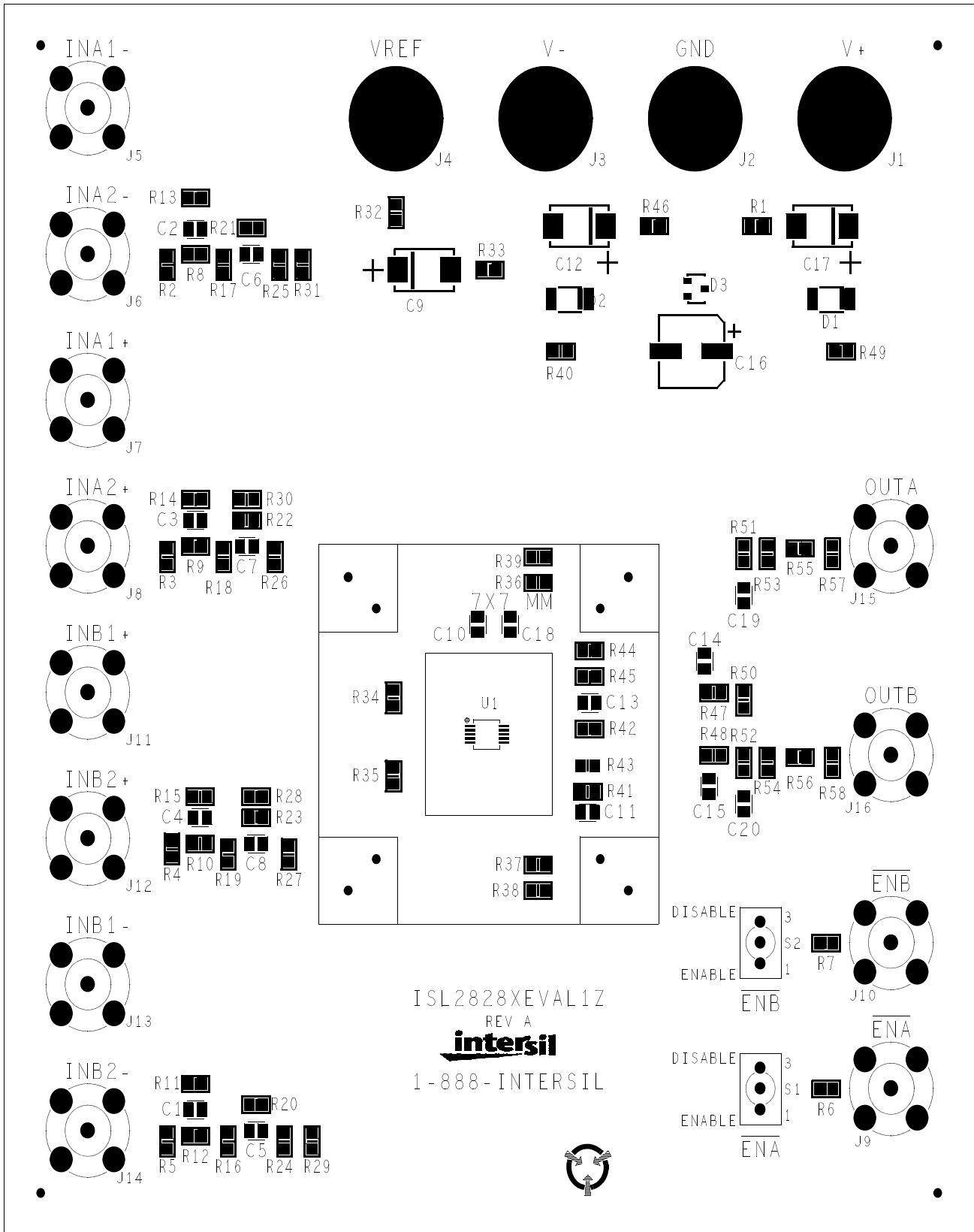

FIGURE 5. OPTIONAL COMPONENTS

ISL2828xEVAL1Z Components Parts List

DEVICE NUMBER	DESCRIPTION	COMMENTS
C9, C12, C17	CAP-TANTALUM, SMD, D, 4.7μF, 50V, 10%, LOW ESR, ROHS	Power supply decoupling
C10,C18	CAP, SMD, 0603, 0.1μF, 25V, 10%, X7R, ROHS	Power supply decoupling
C6-C25	CAP, SMD, 0603, DNP-PLACE HOLDER, ROHS	User selectable capacitors - not populated
D1,D2	DIODE-RECTIFIER, SMD, SOD-123, 2P, 40V, 0.5A, ROHS	Reverse power protection
D3	DIODE-ZENER, SMD, SOD-123, 2P, 5.1V, 350mV, ROHS	Reverse power protection
U1 (ISL28286EVAL1Z)	ISL28286FAZ, IC-RAIL-TO-RAIL PRECISION OP AMP, 16P, QSOP, ROHS	
U1 (ISL28288EVAL1Z)	ISL28288FAZ, IC-RAIL-TO-RAIL PRECISION OP AMP, 16P, QSOP, ROHS	
R2-R5, R8-R10, R12, R16-R19, R24-R27, R29, R31, R34-R39, R42-R44, R50-R52, R57, R58	RESISTOR,SMD, 0603, 0.1%, MF, DNP-PLACE HOLDER	User selectable resistors - not populated
R1, R11, R13-R15, R24, R25, R32, R40, R46-R49, R55, R56	RES, SMD, 0603, 0W, 1/10W, TF, ROHS	0Ω user selectable resistors
R6, R7, R20-R23, R33, R53, R54	RES, SMD, 0603, 10k, 1/10W, 1%, TF, ROHS	RG gain resistors
R28, R30, R41, R45	RES, SMD, 0603, 100k, 1/10W, 1%, TF, ROHS	RF gain resistors

ISL2828xEVAL1Z Top View



ISL2828xEVAL1Z Schematic Diagram

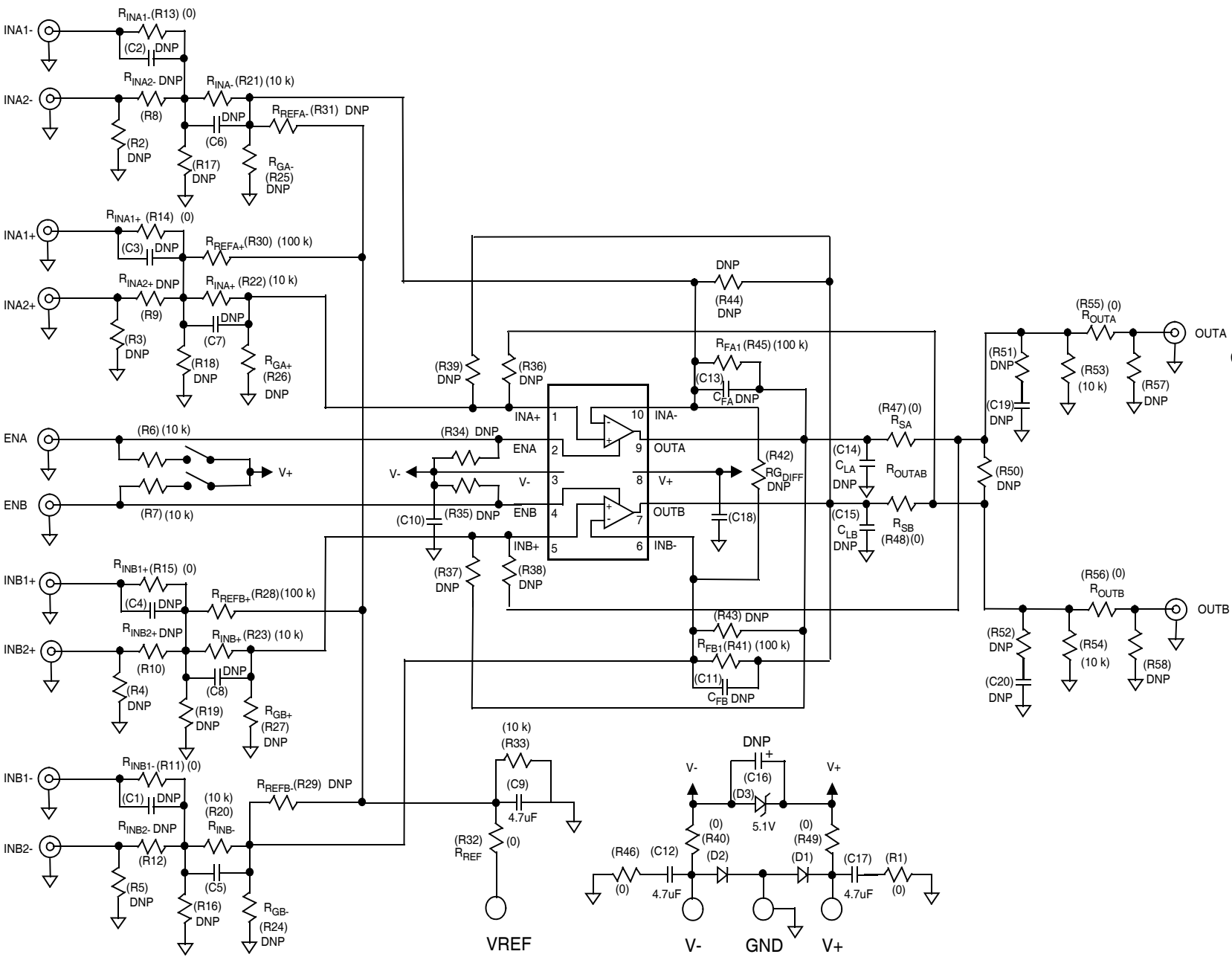

Intersil Corporation reserves the right to make changes in circuit design, software and/or specifications at any time without notice. Accordingly, the reader is cautioned to verify that the Application Note or Technical Brief is current before proceeding.

For information regarding Intersil Corporation and its products, see www.intersil.com