



Chipsmall Limited consists of a professional team with an average of over 10 year of expertise in the distribution of electronic components. Based in Hongkong, we have already established firm and mutual-benefit business relationships with customers from,Europe,America and south Asia,supplying obsolete and hard-to-find components to meet their specific needs.

With the principle of “Quality Parts,Customers Priority,Honest Operation,and Considerate Service”,our business mainly focus on the distribution of electronic components. Line cards we deal with include Microchip,ALPS,ROHM,Xilinx,Pulse,ON,Everlight and Freescale. Main products comprise IC,Modules,Potentiometer,IC Socket,Relay,Connector.Our parts cover such applications as commercial,industrial, and automotives areas.

We are looking forward to setting up business relationship with you and hope to provide you with the best service and solution. Let us make a better world for our industry!



Contact us

Tel: +86-755-8981 8866 Fax: +86-755-8427 6832

Email & Skype: info@chipsmall.com Web: www.chipsmall.com

Address: A1208, Overseas Decoration Building, #122 Zhenhua RD., Futian, Shenzhen, China



Introduction

The ISL2829xEVAL1Z, ISL5529xEVAL1Z evaluation board is a design platform containing all the circuitry needed to characterize critical performance parameters of the ISL28290, ISL28291, ISL55290 and ISL55291 dual op amps, using a variety of user defined test circuits.

The ISL2829x and ISL5529x amplifiers are dual high speed operational amplifiers featuring low noise, low distortion, and rail-to-rail output drive capability. They are designed to operate with single and dual supplies from +5V ($\pm 2.5V$) down to +3V ($\pm 1.5V$).

Reference Documents

- ISL28290 Data Sheet, FN6247
- ISL28291 Data Sheet, FN6156
- ISL55290 Data Sheet, FN6262
- ISL55291 Data Sheet, FN6263

Evaluation Board Key Features

The ISL2829xEVAL1Z, ISL5529xEVAL1Z is designed to enable the IC to operate from a single supply (+3V to +5V), or from split supplies ($\pm 1.5V$ to $\pm 2.5V$). Each op amp in the dual package is independently configured for differential input and for a closed loop gain of 10.

Power Supplies (Figure 1)

External power connections are made through the V_+ , V_- and Ground connections on the evaluation board. For single supply operation, the V_- and Ground pins are tied together to the power supply negative terminal. For split supplies V_+ and

V_- terminals connect to their respective power supply terminals. De-coupling capacitors C_4 , C_9 , connect to ground through R_{17} , R_{18} , 0Ω resistors. Two additional capacitors, C_6 and C_8 are placed close to the IC and provide additional high frequency filtering. Anti-reverse diodes D_1 and D_2 protect the circuit in the case of accidental polarity reversal.

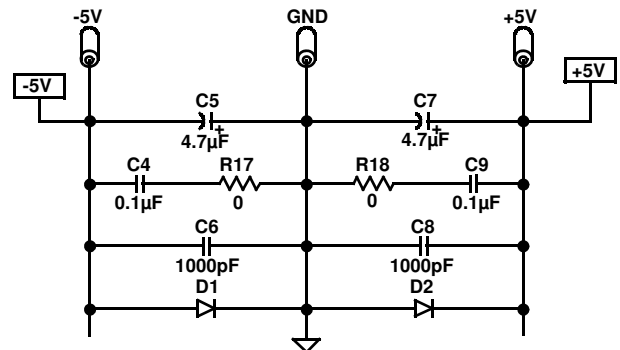

FIGURE 1. POWER SUPPLY CIRCUIT

Amplifier Configuration (Figure 2)

The schematic of each of the 2 op amps with the components supplied is shown in Figure 2. The op amp is configured for low impedance, high speed inputs, and included additional component pads to enable the user to change the input characteristics to suit the application. A series 50Ω back-termination is included for stable operation when driving 50Ω cables.

User-Selectable Options (Figures 3 and 4)

Component pads are included to enable a variety of user-selectable circuits to be added to the amplifier inputs,

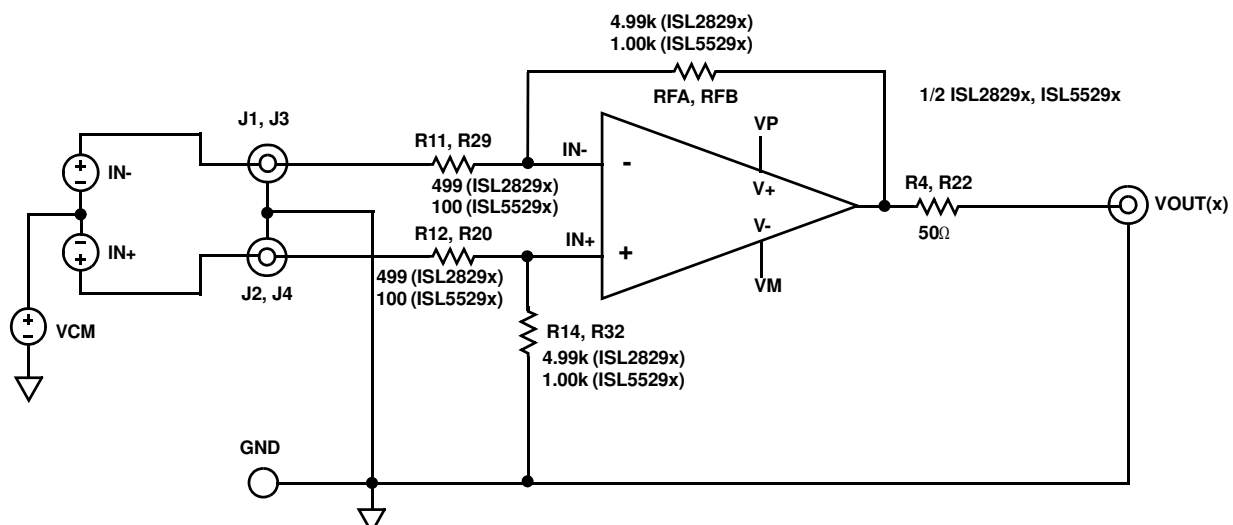

FIGURE 2. BASIC AMPLIFIER CONFIGURATION

Application Note 1343

outputs and the amplifier feedback loops. The outputs (Figure 3) have additional resistor and capacitance placements for loading, and the inverting and non-inverting inputs (Figure 4) have additional resistor placements and auxiliary BNC connectors for added flexibility. ISL5529x op amps are high bandwidth amplifiers and sensitive to input/output parasitics. It is therefore crucial to use appropriate cabling when working with these devices.

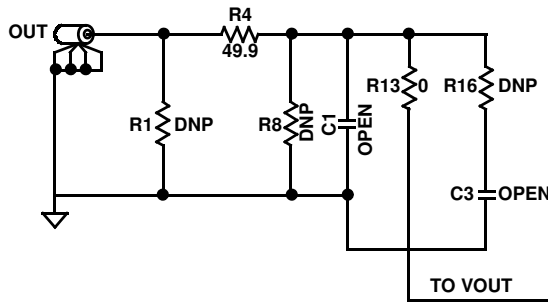

FIGURE 3. 1/2 OUTPUT STAGE

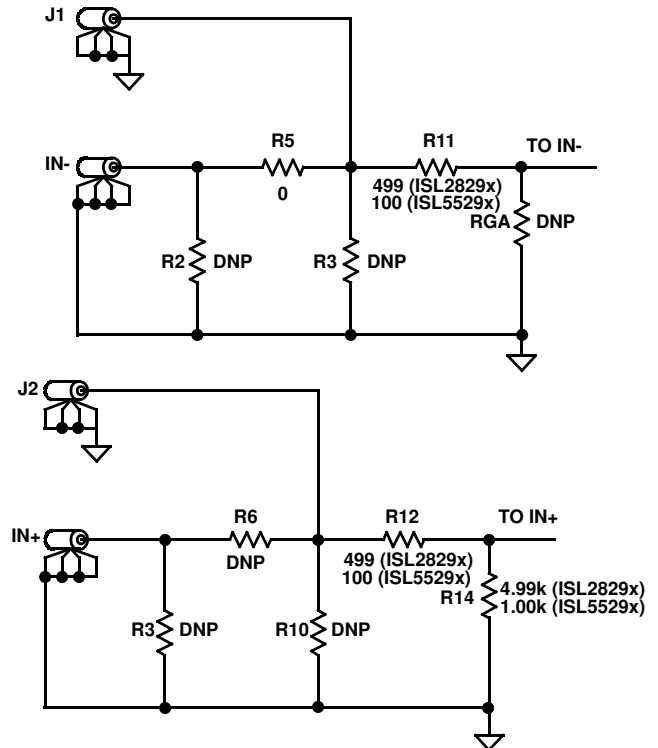
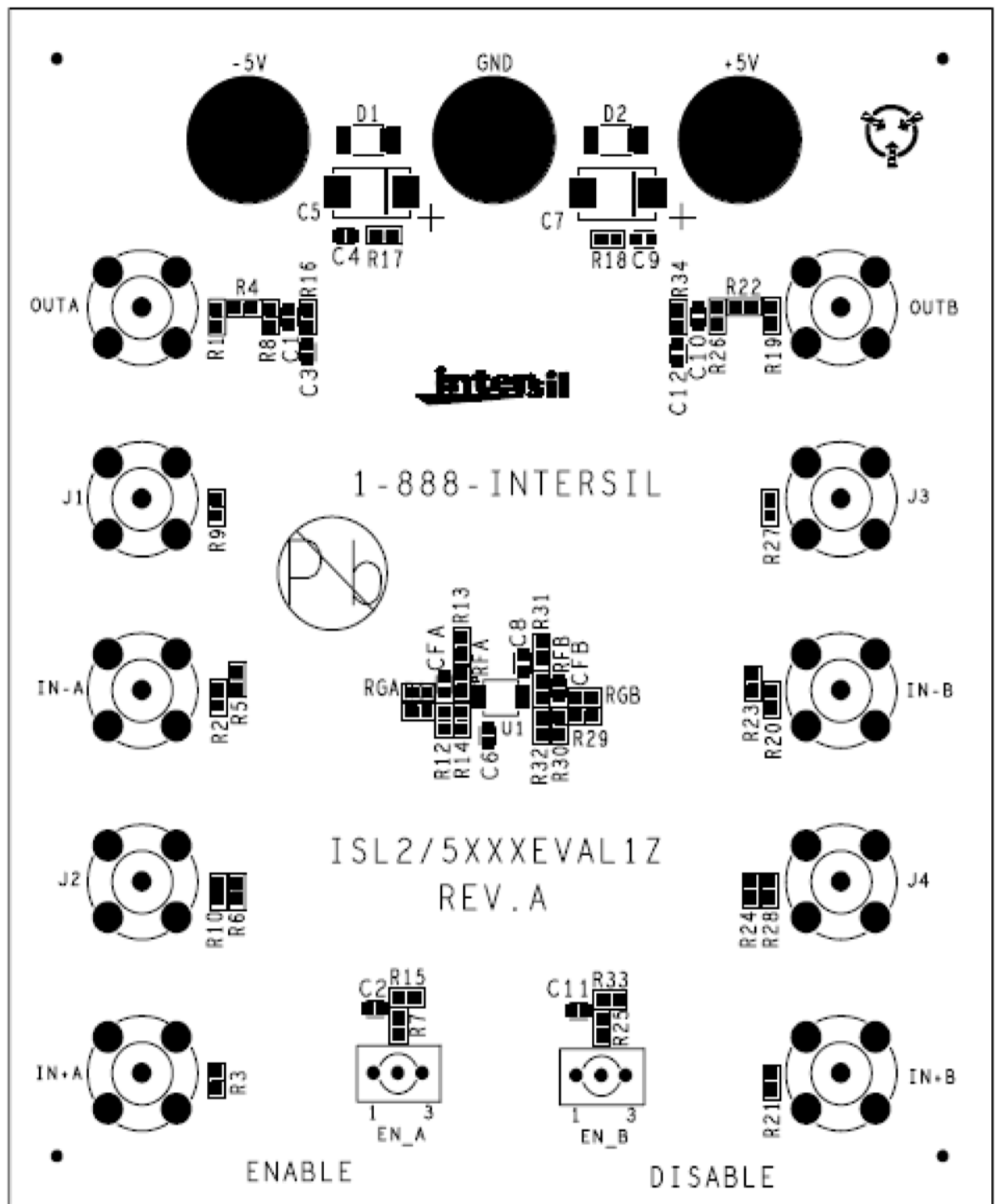

FIGURE 4. 1/2 INPUT STAGE

ISL2829xEVAL1Z, ISL5529xEVAL1Z Components Parts List

DEVICE NUMBER	DESCRIPTION	COMMENTS
C5, C7	CAP-TANTALUM,SMD, D, 4.7μF, 50V, 10%, LOW ESR, ROHS	Power Supply Decoupling
C4, C9	CAP, SMD, 0603, 0.1μF, 25V, 10%, X7R, ROHS	Power Supply Decoupling
C6, C8	CAP, SMD, 0603,1000pF, 25V, 10%, X7R, ROHS	User selectable capacitors - not populated
C1-C3, C10-C12, CFA, CFB	CAP, SMD, 0603, DNP-PLACE HOLDER, ROHS	User selectable capacitors - not populated
D1, D2	DIODE-RECTIFIER, SMD, SOD-123, 2P, 40V, 0.5A, ROHS	Reverse Power Protection
U1 (ISL28290EVAL1Z)	ISL28290FUZ, IC-RAIL-TO-RAIL OP AMP, 10P, MSOP, ROHS	
U1 (ISL28291EVAL1Z)	ISL28291FUZ, IC-RAIL-TO-RAIL OP AMP, 10P, MSOP, ROHS	
U1 (ISL55290EVAL1Z)	ISL55290FUZ, IC-RAIL-TO-RAIL OP AMP, 10P, MSOP, ROHS	
U1 (ISL55291EVAL1Z)	ISL55291FUZ, IC-RAIL-TO-RAIL OP AMP, 10P, MSOP, ROHS	
R1-R3, R6, R8-R10, R15, R16, R19-R21, R24, R26-R28, R33, R34, RGA, RGB	RESISTOR, SMD, 0603, 0.1%, MF, DNP-PLACE HOLDER	User selectable resistors - not populated
R13, R17, R18, R31	RES, SMD, 0603, 0Ω, 1/16W, TF, ROHS	0Ω user selectable resistors
R4, R22	RES, SMD, 0603, 49.9Ω, 1/10W, 1%, TF,ROHS	Output series resistors
R7, R25	RES, SMD, 0603, 10k, 1/10W, 1%, TF,ROHS	Enable pull-up resistors
R14, R32, RFA, RFB	RES, SMD, 0603, 4.99k, 1/10W, 1%, TF, ROHS (ISL2829x) RES, SMD, 0603, 1.00k, 1/10W, 1%, TF, ROHS (ISL5529x)	
R11, R12, R29, R30	RES, SMD, 0805, 499Ω, 1/8W, TF, ROHS (ISL2829x) RES, SMD, 0805, 100Ω, 1/8W, TF, ROHS (ISL5529x)	

ISL2829xEVAL1Z, ISL5529xEVAL1Z Top View



ISL2829xEVAL1Z, ISL5529xEVAL1Z Schematic Diagram

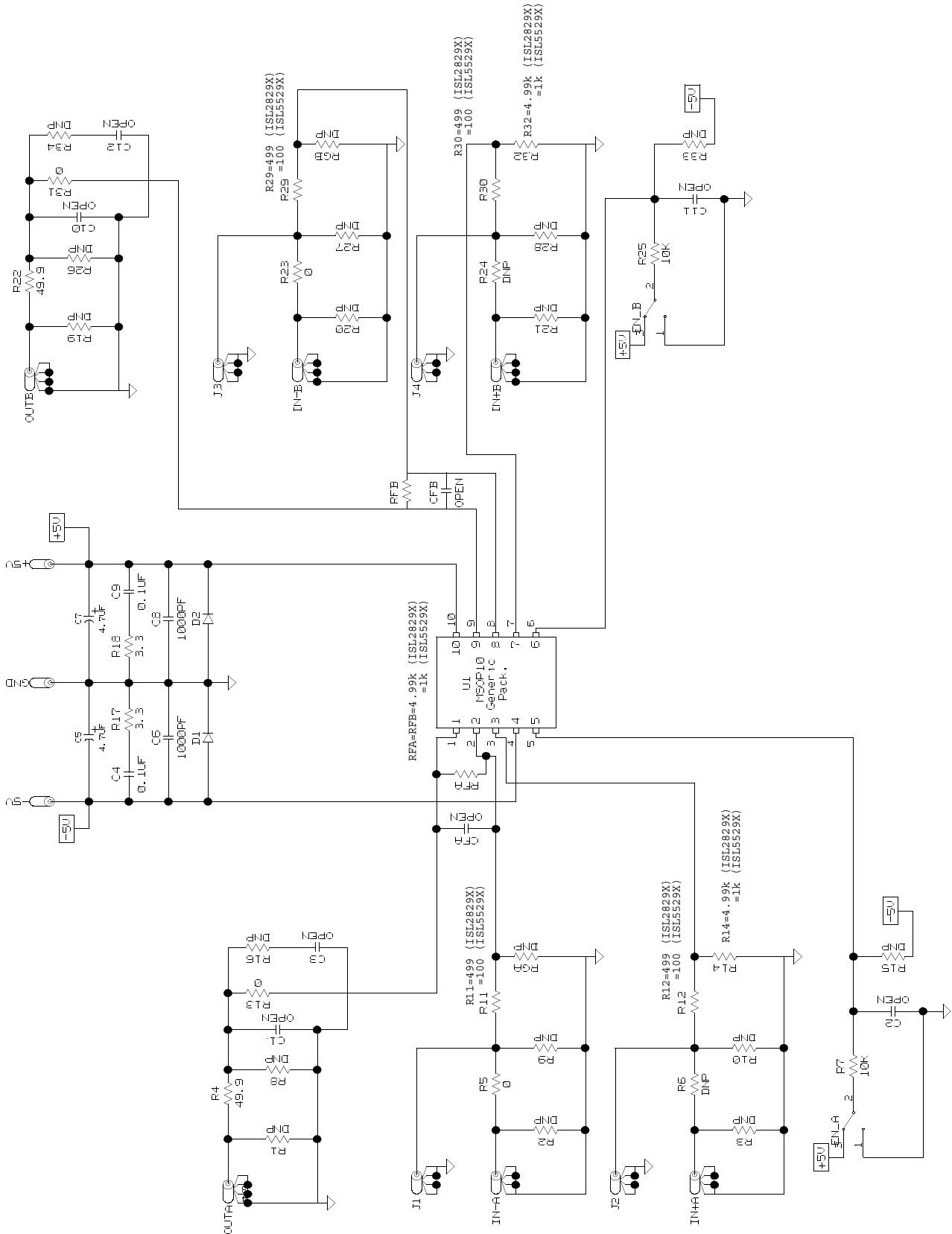

Intersil Corporation reserves the right to make changes in circuit design, software and/or specifications at any time without notice. Accordingly, the reader is cautioned to verify that the Application Note or Technical Brief is current before proceeding.

For information regarding Intersil Corporation and its products, see www.intersil.com