



Chipsmall Limited consists of a professional team with an average of over 10 year of expertise in the distribution of electronic components. Based in Hongkong, we have already established firm and mutual-benefit business relationships with customers from,Europe,America and south Asia,supplying obsolete and hard-to-find components to meet their specific needs.

With the principle of “Quality Parts,Customers Priority,Honest Operation,and Considerate Service”,our business mainly focus on the distribution of electronic components. Line cards we deal with include Microchip,ALPS,ROHM,Xilinx,Pulse,ON,Everlight and Freescale. Main products comprise IC,Modules,Potentiometer,IC Socket,Relay,Connector.Our parts cover such applications as commercial,industrial, and automotives areas.

We are looking forward to setting up business relationship with you and hope to provide you with the best service and solution. Let us make a better world for our industry!



Contact us

Tel: +86-755-8981 8866 Fax: +86-755-8427 6832

Email & Skype: info@chipsmall.com Web: www.chipsmall.com

Address: A1208, Overseas Decoration Building, #122 Zhenhua RD., Futian, Shenzhen, China



Ambient Light Photo Detect IC

The ISL29000 is a light-to-current optical sensor combining a photodiode and a current amplifier on a single monolithic IC. Output current is directly proportionate to the light intensity on the photodiode. Its sensitivity is superior to that of a phototransistor and exhibits little variation. Its spectral sensitivity matches closely to the luminous efficiency and linearity.

Housed in an ultra-compact surface mount clear plastic package, this device is excellent for power saving control function in cell phones, PDAs, and other handheld applications.

Pinout

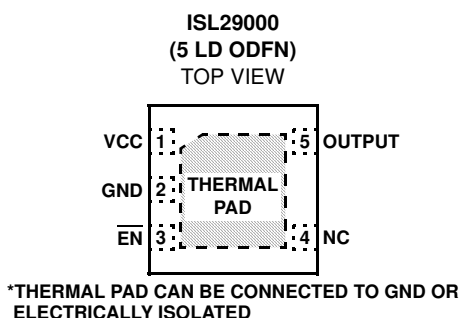

Features

- Monolithic IC containing photodiode and amplifier
- Converts light intensity to current
- 2.5V to 5.5V supply range
- Low supply current: 1µA
- Excellent output linearity of luminance
- Ultra-compact and light surface mount package
- Pb-free (RoHS compliant)

Applications

- Mobile phones
- Notebook PCs
- PDAs
- Video cameras
- Digital cameras

Ordering Information

PART NUMBER (Note)	TEMP RANGE (°C)	PACKAGE (Pb-Free)	PKG. DWG. #
ISL29000IROZ-T7*	-40 to +85	5 Ld ODFN Tape and Reel	L5.2X2.1
ISL29000IROZ-EVALZ	Evaluation Board		

*Please refer to TB347 for details on reel specifications.

NOTE: These Intersil Pb-free plastic packaged products employ special Pb-free material sets; molding compounds/die attach materials and 100% matte tin plate - e3 termination finish, which is RoHS compliant and compatible with both SnPb and Pb-free soldering operations. Intersil Pb-free products are MSL classified at Pb-free peak reflow temperatures that meet or exceed the Pb-free requirements of IPC/JEDEC J STD-020.

Absolute Maximum Ratings ($T_A = +25^\circ\text{C}$)

Supply Voltage between V_{SD} and GND 6V
 Maximum Continuous Output Current 6mA
 Operating Temperature -40°C to $+85^\circ\text{C}$

Thermal Information

Thermal Resistance θ_{JA} ($^\circ\text{C}/\text{W}$)
 ODFN Package 90
 Maximum Die Temperature $+90^\circ\text{C}$
 Storage Temperature -40°C to $+100^\circ\text{C}$
 Pb-free reflow profile see link below
<http://www.intersil.com/pbfree/Pb-FreeReflow.asp>

CAUTION: Do not operate at or near the maximum ratings listed for extended periods of time. Exposure to such conditions may adversely impact product reliability and result in failures not covered by warranty.

IMPORTANT NOTE: All parameters having Min/Max specifications are guaranteed. Typical values are for information purposes only. Unless otherwise noted, all tests are at the specified temperature and are pulsed tests, therefore: $T_J = T_C = T_A$

Electrical Specifications $V_{CC} = 3\text{V}$, $T_A = +25^\circ\text{C}$, unless otherwise specified.

PARAMETER	DESCRIPTION	CONDITION	MIN	TYP	MAX	UNIT
I_{CC}	Supply Current	$R_L = 1\text{k}\Omega$, EV = 1000 lux		74		μA
		EV = 0		0.2		μA
I_{L1}	Light Current	EV = 1000 lux	45	61	75	μA
I_{L2}	Light Current	EV = 100 lux		6.5		μA
I_{LEAK}	Dark Current	EV = 0		0.06		μA
$V_{O(MAX)}$	Maximum Output Compliance Voltage	At 95% of normal output current, EV = 1000 lux		2.7		V
t_R	Rise Time (Note 1)	$R_L = 5\text{k}\Omega$, EV = 1000 lux		27		μs
t_F	Fall Time (Note 1)	$R_L = 5\text{k}\Omega$, EV = 1000 lux		78		μs
t_D	Delay Time for Rising Edge (Note 1)	$R_L = 5\text{k}\Omega$, EV = 1000 lux		80		μs
t_S	Delay Time for Falling Edge (Note 1)	$R_L = 5\text{k}\Omega$, EV = 1000 lux		35		μs
V_{LO}	Maximum Voltage at \overline{EN} Pin to Enable				0.6	V
V_{HI}	Minimum Voltage at \overline{EN} Pin to Disable		1.8			V

NOTE:

1. Switching time measurement is based on Figures 1 and 2.
2. Fluorescent light is substituted by Green LED during production.

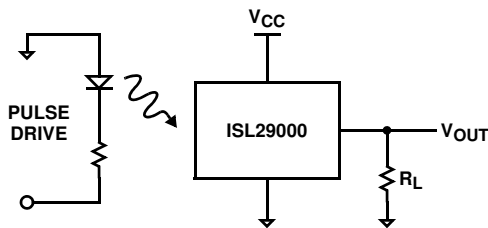

FIGURE 1. RISE/FALL TIME MEASUREMENT

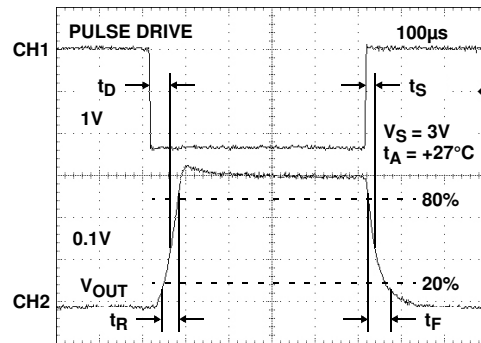

FIGURE 2. RISE/FALL TIME MEASUREMENT WAVEFORMS

Typical Performance Curves

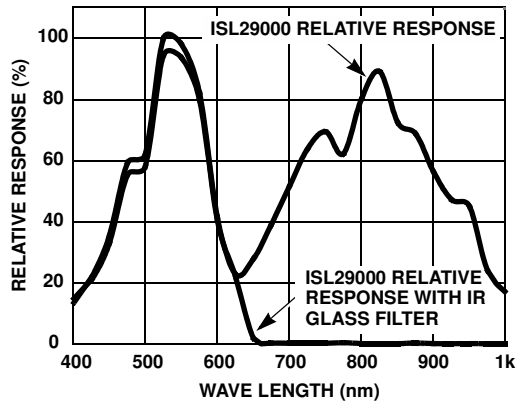

FIGURE 3. SPECTRAL RESPONSE

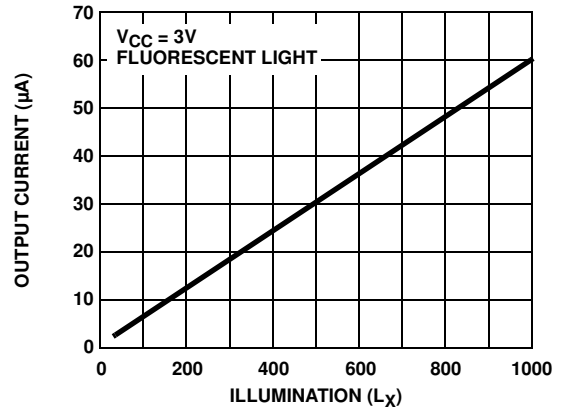

FIGURE 4. SENSITIVITY

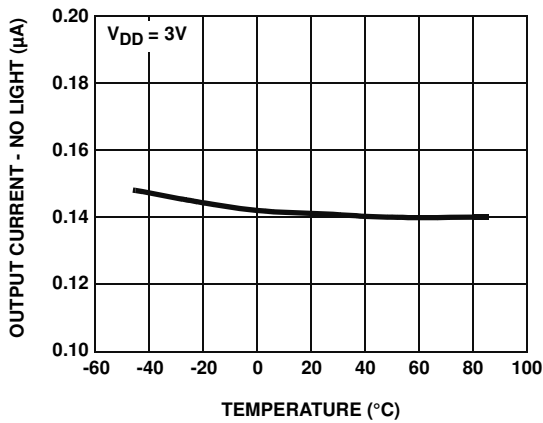

FIGURE 5. DARK CURRENT vs TEMPERATURE

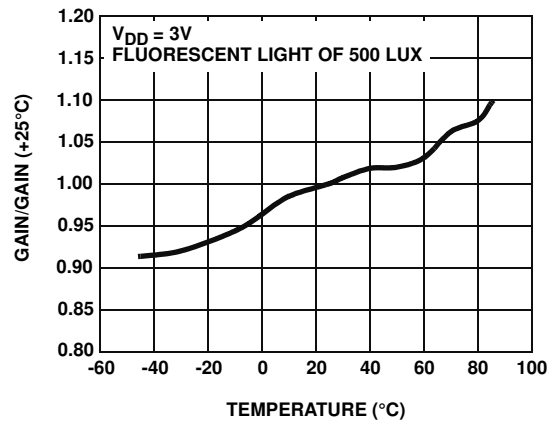

FIGURE 6. GAIN vs TEMPERATURE

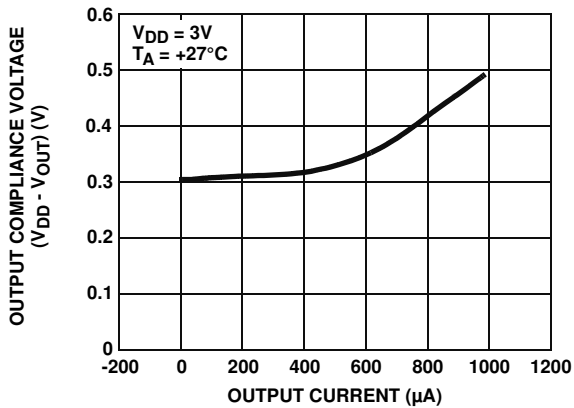

FIGURE 7. OUTPUT COMPLIANCE VOLTAGE vs CURRENT

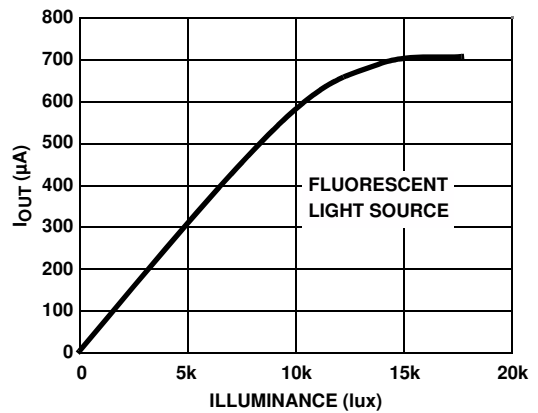
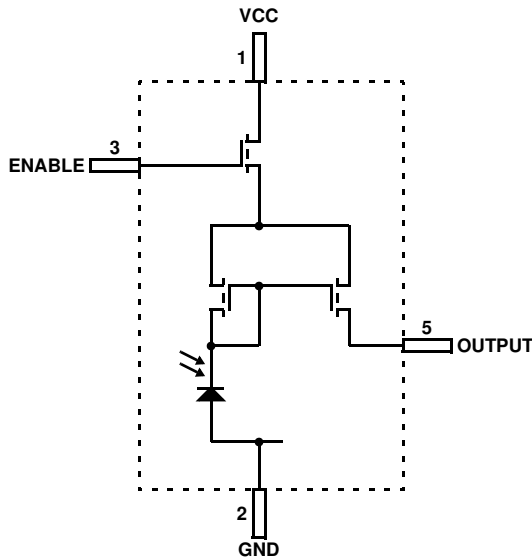

FIGURE 8. I_{OUT} vs LUMINANCE

Pin Descriptions

PIN	NAME	DESCRIPTION
1	VCC	Supply, 2.5V to 5.5V
2	GND	Ground
3	$\overline{\text{EN}}$	Enable
4	NC	No connect
5	Output	Current output pin

Block Diagram



Application Information

Product Description

The ISL29000 is a light-to-current optical sensor combining photodiodes and current amplifiers on a single monolithic IC. The photodiodes are temperature-compensated and their spectrum resembles the human eye response. The output current is directly proportional to the intensity of light falling on the photodiodes. For 100 lux of input fluorescent light, the ISL29000 has an output current of 6.5 μA .

The ISL29000 is housed in an ultra-compact surface mount clear plastic package.

Light-to-Current and Voltage Conversion

The ISL29000 has a responsiveness that is directly proportional to the intensity of light intercepted by the photodiodes. Although the conversion rate varies depending on the light sources (fluorescent light, incandescent light or direct sunlight), in general for a fluorescent light, the light-to-current conversion is:

$$I_{\text{OUT}} = \left(\frac{61\mu\text{A}}{1000\text{Lux}} \right) \times L_{\text{INPUT}} \quad (\text{EQ. 1})$$

Here, I_{OUT} is the output current in μA , and L_{INPUT} is the input light in lux.

For some applications, a load resistor is added between the output and the ground as shown in Figure 1. The output voltage can be expressed in Equation 2:

$$V_{\text{OUT}} = I_{\text{OUT}} \times R_{\text{LOAD}} = \left(\frac{61\mu\text{A}}{1000\text{Lux}} \right) \times L_{\text{INPUT}} \times R_{\text{LOAD}} \quad (\text{EQ. 2})$$

Here, V_{OUT} is the output voltage and R_{LOAD} is the value of the load resistor added. The compliance of the ISL29000's output circuit may result in premature saturation of the output current and voltage when an excessively large R_{LOAD} is used. The output compliance voltage is 300mV below the supply voltage as listed in $V_{\text{O(MAX)}}$ of "Electrical Specifications" on page 2.

In order to have the linear relationship between the input light and the output current and voltage, a proper resistor value (i.e., gain) should be picked for a specific input light range. The resistor value can be picked according to Equation page 4:

$$R_{\text{LOAD}} = \frac{(V_{\text{SUP}} - 0.3\text{V})}{61\mu\text{A}} \times \frac{1000\text{Lux}}{L_{\text{RANGE}}} \quad (\text{EQ. 3})$$

Here, V_{SUP} is the supply voltage, and L_{RANGE} is the specific input light range for an application. For example, an indoor light ranges typically from 0 lux to 1,000 lux. A resistor value of 45k Ω for 3V supply voltage can be used. For a small light range, a large resistor value should be used to achieve better sensitivity; for a large light range, a small resistor value should be used to prevent non-linear output current and voltage.

Resistor Output R_{LOAD} Selection

The resistor output, R_{LOAD} , determines the voltage transfer function of the device. The device converts light into current then R_{LOAD} converts the output current to an output voltage. R_{LOAD} can range from 10 Ω to 10M Ω depending on the input lux levels. The table below lists R_{LOAD} values to maximize output swing for typical lux range levels. A careful balance of dynamic swing and fast response has to be considered when choosing R_{LOAD} . For faster response, choose a smaller value R_{LOAD} to shunt stray capacitances that may slow down response time. For maximum dynamic range or swing, choose a higher value R_{LOAD} . Although finite, the output impedance of the device is considerably large. Hence, the light-to-current conversion deviation because of resistor loading is infinitesimal. The recommended maximum R_{LOAD} is 10M Ω .

Although the device saturates at 10,000 lux ($I_{\text{OUT}} = 600\mu\text{A}$), the output current must never exceed 6mA. The voltage output compliance of the device is 300mV below the supply. The output current stops ramping when the output voltage reaches voltage compliance.

TABLE 1. $V_{DD} = 5V$, MAXIMUM OUTPUT VOLTAGE = 4.7V

ILLUMINATION RANGE (LUX)	RLOAD (kΩ)	CURRENT OUT (μA)
0 to 10	7830	0 to 0.6
0 to 200	392	0 to 12
0 to 500	157	0 to 30
0 to 1,000	80	0 to 60
0 to 10,000	8.00	0 to 600

Application Examples

The following examples present from fully automatic to fully manual override implementations. These guidelines are applicable to a wide variety of potential light control applications. The ISL29000 can be used to control the brightness input of CCFL inverters. Likewise it can interface well with LED drivers. In each specific application, it is important to recognize the target environment and its ambient light conditions. The mechanical mounting of the sensor, light aperture hole size and use of a light pipe or bezel are critical in determining the response of the ISL29000 for a given exposure of light.

The example in Figure 9 shows a fully automatic dimming solution with no user interaction. Choose R_1 and R_2 values for any desired minimum brightness and slope. Choose C_1 to adjust response time and to filter 50/60Hz room lighting. For example, suppose you wish to generate an output voltage from 0.25V to 1.25V to drive the input of an LED driver controller. The 0.25V represents the minimum LED brightness and 1.25V represents the maximum. The 1st step would be to determine the ratio of R_1 and R_2 :

$$R_1 = R_2 \times \left(\frac{3.0V}{0.25V} - 1 \right) = 11 \times R_2 \tag{EQ. 4}$$

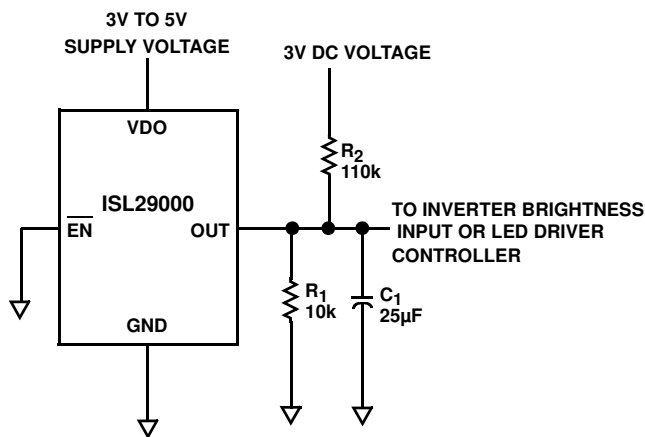

FIGURE 9. AUTOMATIC DIMMING SOLUTION

Next, the value of R_2 can be calculated based on the maximum output current coming from the ISL29000 under the application's maximum light exposure. Suppose the current has been determined to be about 125μA. Thus, R_2 can be calculated approximately using Equations 5 and 6:

$$R_2 = \left(\frac{1.25V}{125\mu A} \right) = 10k\Omega \tag{EQ. 5}$$

and

$$R_1 = 11 \times R_2 = 110k\Omega \tag{EQ. 6}$$

In Figure 10, user adjustable bias control has been added to allow control over the minimum and maximum output voltage. This allows the user to adjust the output brightness to personal preference over a limit range via the 3V PWM control.

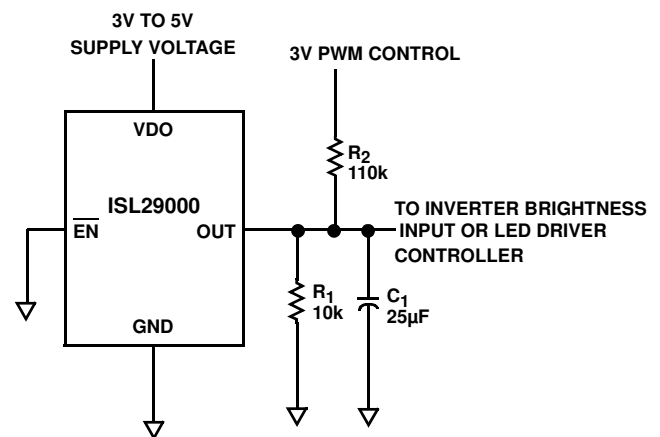

FIGURE 10. AUTOMATIC DIMMING SOLUTION WITH ADJUSTABLE BIAS CONTROL

Figure 11 shows how a fully manual override can be quickly added by using the \overline{EN} pin.

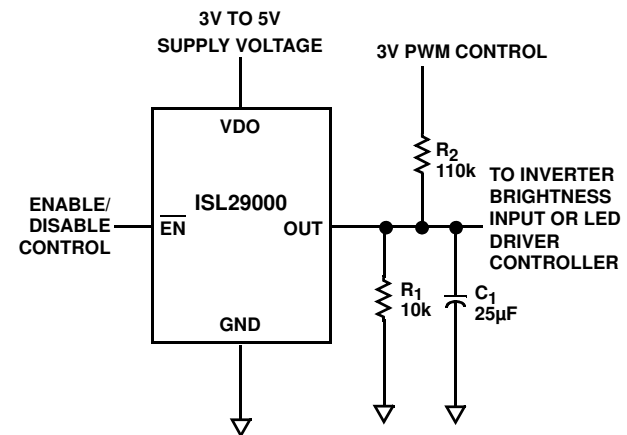

FIGURE 11. AUTOMATIC DIMMING SOLUTION WITH ADJUSTABLE BIAS CONTROL AND MANUAL OVERRIDE

Short Circuit Current Limit

The ISL29000 does not limit the output short circuit current. If the output is directly shorted to the ground continuously, the output current could easily increase for a strong input light such that the device may be damaged. Maximum reliability is maintained if the output continuous current never exceeds 6mA by adding a load resistor at the output. This limit is set by the design of the internal metal interconnects.

Suggested PCB Footprint

Footprint pads should be a nominal 1-to-1 correspondence with package pads. The large, exposed central die-mounting paddle in the center of the package requires neither thermal nor electrical connections to PCB, and such connections should be avoided.

Power Supply Bypassing and Printed Circuit Board Layout

The ISL29000 is relatively insensitive to the printed circuit board layout due to its low speed operation. Nevertheless, good printed circuit board layout is necessary for optimum performance. Ground plane construction is highly recommended, lead length should be as short as possible and the power supply pins must be well bypassed to reduce the risk of oscillation. For normal single supply operation, where the GND pin is connected to ground, a 0.1 μ F ceramic capacitor should be placed from VCC pin to GND pin. A 4.7 μ F tantalum capacitor should then be connected in parallel, placed close to the device.

For additional products, see www.intersil.com/en/products.html

Intersil products are manufactured, assembled and tested utilizing ISO9000 quality systems as noted in the quality certifications found at www.intersil.com/en/support/qualandreliability.html

Intersil products are sold by description only. Intersil Corporation reserves the right to make changes in circuit design, software and/or specifications at any time without notice. Accordingly, the reader is cautioned to verify that data sheets are current before placing orders. Information furnished by Intersil is believed to be accurate and reliable. However, no responsibility is assumed by Intersil or its subsidiaries for its use; nor for any infringements of patents or other rights of third parties which may result from its use. No license is granted by implication or otherwise under any patent or patent rights of Intersil or its subsidiaries.

For information regarding Intersil Corporation and its products, see www.intersil.com

Package Outline Drawing

L5.2x2.1

5 LEAD OPTICAL DUAL FLAT NO-LEAD PLASTIC PACKAGE

Rev 1, 05/08

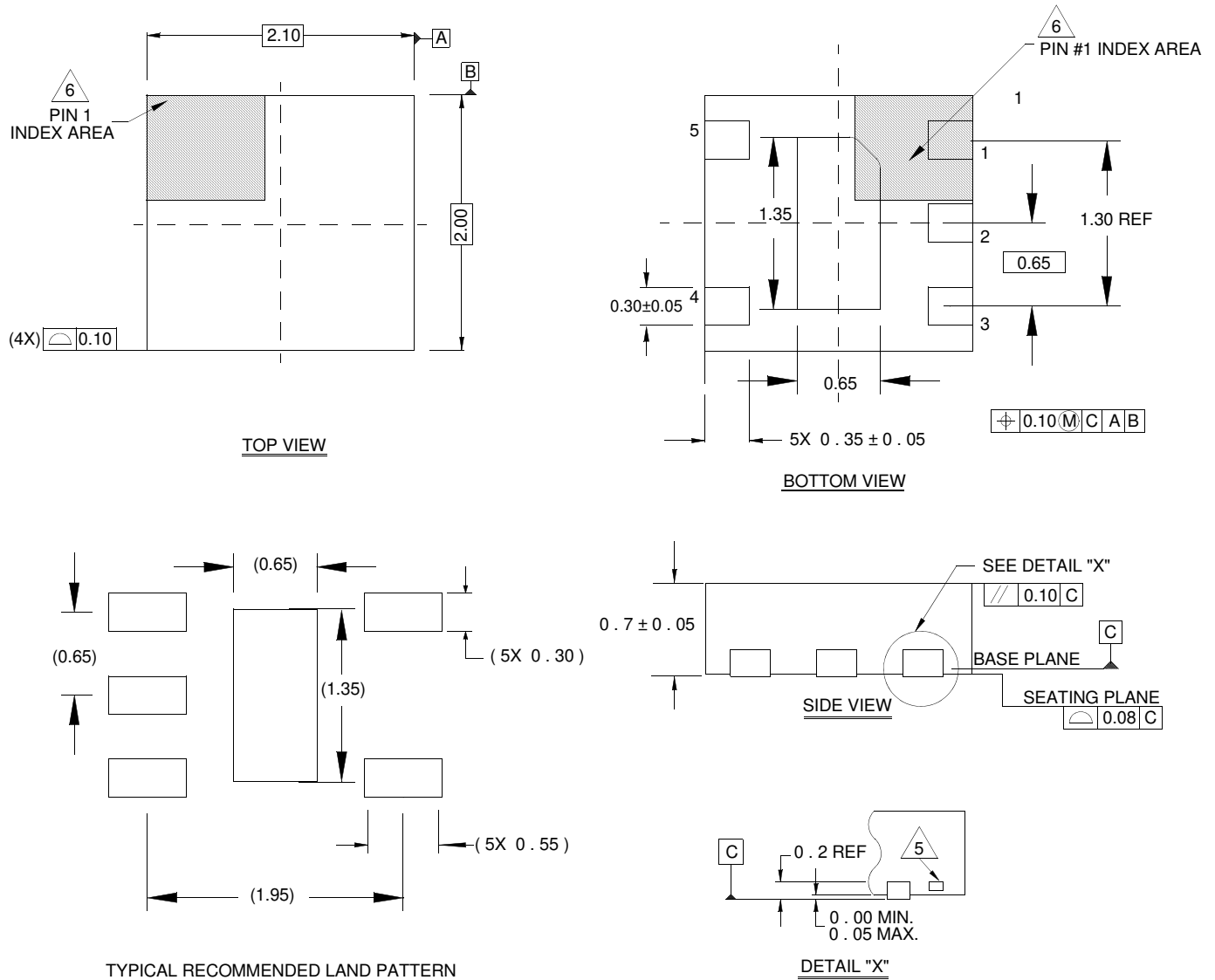

NOTES:

1. Dimensions are in millimeters.
Dimensions in () for Reference Only.
2. Dimensioning and tolerancing conform to AMSE Y14.5m-1994.
3. Unless otherwise specified, tolerance : Decimal ± 0.05
4. Dimension b applies to the metallized terminal and is measured between 0.15mm and 0.30mm from the terminal tip.
5. Tiebar shown (if present) is a non-functional feature.
6. The configuration of the pin #1 identifier is optional, but must be located within the zone indicated. The pin #1 identifier may be either a mold or mark feature.