



Chipsmall Limited consists of a professional team with an average of over 10 year of expertise in the distribution of electronic components. Based in Hongkong, we have already established firm and mutual-benefit business relationships with customers from,Europe,America and south Asia,supplying obsolete and hard-to-find components to meet their specific needs.

With the principle of “Quality Parts,Customers Priority,Honest Operation,and Considerate Service”,our business mainly focus on the distribution of electronic components. Line cards we deal with include Microchip,ALPS,ROHM,Xilinx,Pulse,ON,Everlight and Freescale. Main products comprise IC,Modules,Potentiometer,IC Socket,Relay,Connector.Our parts cover such applications as commercial,industrial, and automotives areas.

We are looking forward to setting up business relationship with you and hope to provide you with the best service and solution. Let us make a better world for our industry!



## Contact us

Tel: +86-755-8981 8866 Fax: +86-755-8427 6832

Email & Skype: info@chipsmall.com Web: www.chipsmall.com

Address: A1208, Overseas Decoration Building, #122 Zhenhua RD., Futian, Shenzhen, China



### 3.3V, ±15kV ESD Protected, Dual Protocol (RS-232/RS-485) Transceivers

These devices are BiCMOS interface ICs that are user configured as either a single RS-422/RS-485 differential transceiver, or as a dual (2 Tx, 2 Rx) RS-232 transceiver.

In RS-232 mode, the on-board charge pump generates RS-232 compliant ±5V Tx output levels, from a supply as low as 3.15V. Four small 0.1µF capacitors are required for the charge pump. The transceivers are RS-232 compliant, with the Rx inputs handling up to ±25V.

In RS-485 mode, the transceivers support both the RS-485 and RS-422 differential communication standards. The RS-485 receiver features "full failsafe" operation, so the Rx output remains in a high state if the inputs are open or shorted together. The RS-485 transmitter supports up to three data rates, two of which are slew rate limited for problem free communications. The charge pump disables in RS-485 mode, thereby saving power, minimizing noise, and eliminating the charge pump capacitors.

Both RS-232/RS-485 modes feature loopback and shutdown functions. The loopback mode internally connects the Tx outputs to the corresponding Rx input, which facilitates the implementation of board level self test functions. The outputs remain connected to the loads during loopback, where connection problems (e.g., shorted connectors or cables) can be detected. The shutdown mode disables the Tx and Rx outputs, disables the charge pump if in RS-232 mode, and places the IC in a low current (30µA) mode.

The ISL3331 is a QFN packaged device that offers additional functionality, including a lower speed and edge rate option (115kbps) for EMI sensitive designs, or to allow longer bus lengths. It also features a logic supply voltage pin ( $V_L$ ) that sets the  $V_{OH}$  level of logic outputs, and the switching points of logic inputs, to be compatible with another supply voltage in mixed voltage systems. The QFN's choice of active high or low Rx enable pins increases design flexibility, allowing Tx/Rx direction control via a single signal by connecting DEN and RXEN together.

For a dual port version of these devices, please see the ISL3332/ISL3333 data sheet.

### Features

- User Selectable RS-232 or RS-485/RS-422 Interface Port (Two RS-232 Transceivers or One RS-485/RS-422 Transceiver)
- Operates From a Single 3.3V Supply
- ±15kV (HBM) ESD Protected Bus Pins (RS-232 or RS-485)
- 5V Tolerant Logic Inputs
- True Flow-Through Pinouts Simplify Board Layouts
- Pb-Free (RoHS Compliant)
- Full Failsafe (Open/Short) Rx in RS-485/RS-422 Mode
- Loopback Mode Facilitates Board Self Test Functions
- User Selectable RS-485 Data Rates . . . . . 20Mbps
  - Slew Rate Limited. . . . . 460kbps
  - Slew Rate Limited (ISL3331 Only) . . . . . 115kbps
- Fast RS-232 Data Rate . . . . . Up to 400kbps
- Low Current Shutdown Mode. . . . . 30µA
- QFN Package Saves Board Space (ISL3331 Only)
- Logic Supply Pin ( $V_L$ ) Eases Operation in Mixed Supply Systems (ISL3331 Only)

### Applications

- Gaming Applications (e.g., Slot machines)
- Single Board Computers
- Factory Automation
- Security Networks
- Industrial/Process Control Networks
- Level Translators (e.g., RS-232 to RS-422)
- Point of Sale Equipment

### Related Literature

- Application Note AN1401 "Implementing a Three Pin, Half-Duplex, Dual Protocol Interface"

**TABLE 1. SUMMARY OF FEATURES**

PART NUMBER	NO. OF PORTS	PACKAGE OPTIONS	RS-485 DATA RATE (bps)	RS-232 DATA RATE (kbps)	$V_L$ PIN?	ACTIVE H or L Rx ENABLE?	LOW POWER SHUTDOWN?
ISL3330	1	20 Ld SSOP	20M, 460k	400	No	H	Yes
ISL3331	1	40 Ld QFN (6mmx6mm)	20M, 460k, 115k	400	Yes	Both	Yes

**Ordering Information**

PART NUMBER (NOTE)	PART MARKING	TEMP. RANGE (°C)	PACKAGE (Pb-Free)	PKG. DWG. #
ISL3330IAZ	3330 IAZ	-40 to +85	20 Ld SSOP	M20.209
ISL3330IAZ-T*	3330 IAZ	-40 to +85	20 Ld SSOP (Tape and Reel)	M20.209
ISL3331IRZ	ISL3331IRZ	-40 to +85	40 Ld 6x6 QFN	L40.6x6
ISL3331IRZ-T*	ISL3331IRZ	-40 to +85	40 Ld 6x6 QFN (Tape and Reel)	L40.6x6

\*Please refer to TB347 for details on reel specifications.

NOTE: These Intersil Pb-free plastic packaged products employ special Pb-free material sets, molding compounds/die attach materials, and 100% matte tin plate plus anneal (e3 termination finish, which is RoHS compliant and compatible with both SnPb and Pb-free soldering operations). Intersil Pb-free products are MSL classified at Pb-free peak reflow temperatures that meet or exceed the Pb-free requirements of IPC/JEDEC J STD-020.

**Pinouts**

ISL3330  
(20 LD SSOP)  
TOP VIEW

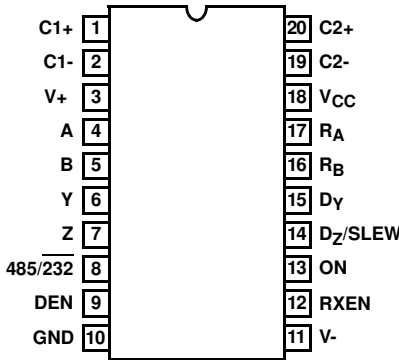

ISL3331  
(40 LD QFN)  
TOP VIEW

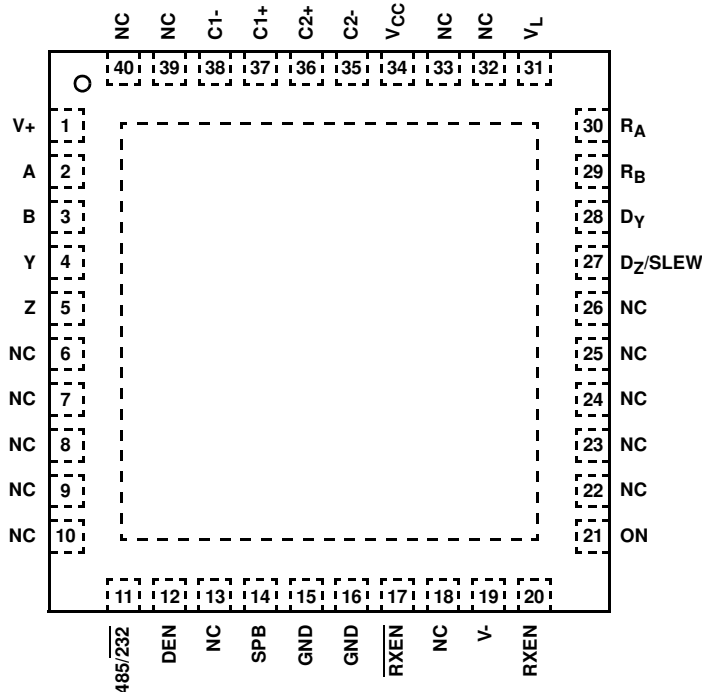



TABLE 2. ISL3330 FUNCTION TABLE

INPUTS					RECEIVER OUTPUTS		DRIVER OUTPUTS		DRIVER SPEED (Mbps)	CHARGE PUMPS (Note 1)	LOOPBACK (Note 2)	MODE
485/232	ON	RXEN	DEN	SLEW	R <sub>A</sub>	R <sub>B</sub>	Y	Z				
0	1	0	0	N/A	High-Z	High-Z	High-Z	High-Z	-	ON	OFF	RS-232
0	1	0	1	N/A	High-Z	High-Z	ON	ON	0.46	ON	OFF	RS-232
0	1	1	0	N/A	ON	ON	High-Z	High-Z	-	ON	OFF	RS-232
0	1	1	1	N/A	ON	ON	ON	ON	0.46	ON	OFF	RS-232
0	0	0	1	N/A	High-Z	High-Z	ON	High-Z	0.46	ON	OFF	RS-232
0	0	1	0	N/A	High-Z	ON	ON	High-Z	0.46	ON	OFF	RS-232
0	0	1	1	N/A	ON	ON	ON	ON	0.46	ON	ON	RS-232
X	0	0	0	X	High-Z	High-Z	High-Z	High-Z	-	OFF	OFF	Shutdown
1	1	0	0	X	High-Z	High-Z	High-Z	High-Z	-	OFF	OFF	RS-485
1	X	0	1	1/0	High-Z	High-Z	ON	ON	20/0.46	OFF	OFF	RS-485
1	X	1	0	X	ON	High-Z	High-Z	High-Z	-	OFF	OFF	RS-485
1	1	1	1	1/0	ON	High-Z	ON	ON	20/0.46	OFF	OFF	RS-485
1	0	1	1	1/0	ON	High-Z	ON	ON	20/0.46	OFF	ON	RS-485

NOTES:

1. Charge pumps are on in RS-232 mode and ON or DEN or RXEN are high.
2. Loopback is enabled when ON = 0, and DEN = RXEN = 1.

ISL3330 Truth Tables

RS-232 TRANSMITTING MODE					
INPUTS (ON = 1)				OUTPUTS	
485/232	DEN	D <sub>Y</sub>	D <sub>Z</sub>	Y	Z
0	1	0	0	1	1
0	1	0	1	1	0
0	1	1	0	0	1
0	1	1	1	0	0
0	0	X	X	High-Z	High-Z

RS-232 RECEIVING MODE					
INPUTS (ON = 1)				OUTPUT	
485/232	RXEN	A	B	R <sub>A</sub>	R <sub>B</sub>
0	1	0	0	1	1
0	1	0	1	1	0
0	1	1	0	0	1
0	1	1	1	0	0
0	1	Open	Open	1	1
0	0	X	X	High-Z	High-Z

RS-485 TRANSMITTING MODE						
INPUTS (ON = 1)				OUTPUTS		
485/232	DEN	D <sub>Y</sub>	SLEW	Y	Z	DATA RATE (Mbps)
1	1	0	1	1	0	20
1	1	1	1	0	1	20
1	1	0	0	1	0	0.46
1	1	1	0	0	1	0.46
1	0	X	X	High-Z	High-Z	-

RS-485 RECEIVING MODE				
INPUTS (ON = 1)			OUTPUT	
485/232	RXEN	B-A	R <sub>A</sub>	R <sub>B</sub>
1	1	≥ -40mV	1	High-Z
1	1	≤ -200mV	0	High-Z
1	1	Open or Shorted together	1	High-Z
1	0	X	High-Z	High-Z

TABLE 3. ISL3331 FUNCTION TABLE

INPUTS						RECEIVER OUTPUTS		DRIVER OUTPUTS		DRIVER DATA RATE (Mbps)	CHARGE PUMPS (Note 3)	MODE
485/232	ON	R $\overline{\text{XEN}}$ AND/OR RXEN	DEN	SLEW	SPB	R $_A$	R $_B$	Y	Z			
0	1	1 and 0	0	N/A	N/A	High-Z	High-Z	High-Z	High-Z	-	ON	RS-232
0	1	1 and 0	1	N/A	N/A	High-Z	High-Z	ON	ON	0.46	ON	RS-232
0	1	0 or 1	0	N/A	N/A	ON	ON	High-Z	High-Z	-	ON	RS-232
0	1	0 or 1	1	N/A	N/A	ON	ON	ON	ON	0.46	ON	RS-232
0	0	1 and 0	1	N/A	N/A	High-Z	High-Z	ON	High-Z	0.46	ON	RS-232
0	0	0 or 1	0	N/A	N/A	High-Z	ON	ON	High-Z	0.46	ON	RS-232
0	0	0 or 1	1	N/A	N/A	ON	ON	ON	ON	0.46	ON	RS-232 (Note 4)
X	0	1 and 0	0	X	X	High-Z	High-Z	High-Z	High-Z	-	OFF	Shutdown
1	1	1 and 0	0	X	X	High-Z	High-Z	High-Z	High-Z	-	OFF	RS-485
1	X	1 and 0	1	0	1/0	High-Z	High-Z	ON	ON	0.46/0.115	OFF	RS-485
1	X	1 and 0	1	1	X	High-Z	High-Z	ON	ON	20	OFF	RS-485
1	X	0 or 1	0	X	X	ON	High-Z	High-Z	High-Z	-	OFF	RS-485
1	1	0 or 1	1	0	1/0	ON	High-Z	ON	ON	0.46/0.115	OFF	RS-485
1	1	0 or 1	1	1	X	ON	High-Z	ON	ON	20	OFF	RS-485
1	0	0 or 1	1	0	1/0	ON	High-Z	ON	ON	0.46/0.115	OFF	RS-485 (Note 4)
1	0	0 or 1	1	1	X	ON	High-Z	ON	ON	20	OFF	RS-485 (Note 4)

NOTES:

- Charge pumps are on in RS-232 mode and ON or DEN or RXEN is high, or  $\overline{\text{RXEN}}$  is low.
- Loopback is enabled when ON = 0, and DEN = 1, and (RXEN = 1 or  $\overline{\text{RXEN}}$  = 0).

ISL3331 Truth Tables

RS-232 TRANSMITTING MODE					
INPUTS (ON = 1)				OUTPUTS	
485/232	DEN	D $_Y$	D $_Z$	Y	Z
0	1	0	0	1	1
0	1	0	1	1	0
0	1	1	0	0	1
0	1	1	1	0	0
0	0	X	X	High-Z	High-Z

RS-232 RECEIVING MODE					
INPUTS (ON = 1)				OUTPUT	
485/232	R $\overline{\text{XEN}}$ and/or RXEN	A	B	R $_A$	R $_B$
0	0 or 1	0	0	1	1
0	0 or 1	0	1	1	0
0	0 or 1	1	0	0	1
0	0 or 1	1	1	0	0
0	0 or 1	Open	Open	1	1
0	1 and 0	X	X	High-Z	High-Z

RS-485 TRANSMITTING MODE							
INPUTS (ON = 1)					OUTPUTS		DATA
485/232	DEN	SLEW	SPB	D $_Y$	Y	Z	Mbps
1	1	0	0	0/1	1/0	0/1	0.115
1	1	0	1	0/1	1/0	0/1	0.460
1	1	1	X	0/1	1/0	0/1	20
1	0	X	X	X	High-Z	High-Z	-

RS-485 RECEIVING MODE				
INPUTS (ON = 1)			OUTPUT	
485/232	R $\overline{\text{XEN}}$ and/or RXEN	B-A	R $_A$	R $_B$
1	0 or 1	$\geq -40\text{mV}$	1	High-Z
1	0 or 1	$\leq -200\text{mV}$	0	High-Z
1	0 or 1	Open or Shorted together	1	High-Z
1	1 and 0	X	High-Z	High-Z

**Pin Descriptions**

PIN	MODE	FUNCTION
485/232	BOTH	Interface Mode Select input. High for RS-485 Mode and low for RS-232 Mode.
DEN	BOTH	Driver output enable. The driver outputs, Y and Z, are enabled by bringing DEN high. They are high impedance when DEN is low.
GND	BOTH	Ground connection.
NC	BOTH	No Connection.
ON	BOTH	In RS-232 mode only, ON high enables the charge pumps. ON low, with DEN and RXEN low (and $\overline{RXEN}$ high if QFN), turns off the charge pumps (in RS-232 mode), and in either mode places the device in low power shutdown. In both modes, when ON is low, and DEN is high, and RXEN is high or $\overline{RXEN}$ is low, loopback is enabled.
RXEN	BOTH	Receiver <u>output</u> enable. Rx is enabled when RXEN is high; Rx is high impedance when $\overline{RXEN}$ is low and, if using the QFN package, $\overline{RXEN}$ is high. When using the QFN and the active high Rx enable function, $\overline{RXEN}$ should be high or floating.
$\overline{RXEN}$	BOTH	Active low receiver output enable. Rx is enabled when $\overline{RXEN}$ is low; Rx is high impedance when $\overline{RXEN}$ is high and RXEN is low. (i.e., to use active low Rx enable function, tie RXEN to GND). For single signal Tx/Rx direction control, connect RXEN to DEN. Internally pulled high. (QFN only)
V <sub>CC</sub>	BOTH	System power supply input (3.3V).
V <sub>L</sub>	BOTH	Logic-Level Supply. All TTL/CMOS inputs and outputs are powered by this supply. QFN logic input pins that are externally tied high in an application, should use the V <sub>L</sub> supply for the high voltage level. (QFN only)
A	RS-232	Receiver input with ±15kV ESD protection. A low on A forces R <sub>A</sub> high; A high on A forces R <sub>A</sub> low.
	RS-485	Inverting receiver input with ±15kV ESD protection.
B	RS-232	Receiver input with ±15kV ESD protection. A low on B forces R <sub>B</sub> high; A high on B forces R <sub>B</sub> low.
	RS-485	Noninverting receiver input with ±15kV ESD protection.
D <sub>Y</sub>	RS-232	Driver input. A low on D <sub>Y</sub> forces output Y high. Similarly, a high on D <sub>Y</sub> forces output Y low.
	RS-485	Driver input. A low on D <sub>Y</sub> forces output Y high and output Z low. Similarly, a high on D <sub>Y</sub> forces output Y low and output Z high.
D <sub>Z</sub> /SLEW	RS-232	Driver input. A low on D <sub>Z</sub> forces output Z high. Similarly, a high on D <sub>Z</sub> forces output Z low.
	RS-485	Slew rate control. With the SLEW pin high, the drivers run at the maximum slew rate (20Mbps). With the SLEW pin low, the drivers run at a reduced slew rate (460kbps). The QFN version works in conjunction with SPB to select one of three RS-485 data rates. Internally pulled high in RS-485 mode.
SPB	RS-485	Speed control. Works in conjunction with the SLEW pin to select the 20Mbps, 460kbps or 115kbps RS-485 data rate. Internally pulled high. (QFN only)
R <sub>A</sub>	RS-232	Receiver output.
	RS-485	Receiver output: If B > A by at least -40mV, R <sub>A</sub> is high; If B < A by -200mV or more, R <sub>A</sub> is low; R <sub>A</sub> = High if A and B are unconnected (floating) or shorted together (i.e., full fail-safe).
R <sub>B</sub>	RS-232	Receiver output.
	RS-485	Not used. Output is high impedance, and unaffected by $\overline{RXEN}$ and RXEN.
Y	RS-232	Driver output with ±15kV ESD protection.
	RS-485	Inverting driver output with ±15kV ESD protection.
Z	RS-232	Driver output with ±15kV ESD protection.
	RS-485	Noninverting driver output with ±15kV ESD protection.
C1+	RS-232	External capacitor (voltage doubler) is connected to this lead. Not needed in RS-485 Mode.
C1-	RS-232	External capacitor (voltage doubler) is connected to this lead. Not needed in RS-485 Mode.
C2+	RS-232	External capacitor (voltage inverter) is connected to this lead. Not needed in RS-485 Mode.
C2-	RS-232	External capacitor (voltage inverter) is connected to this lead. Not needed in RS-485 Mode.
V+	RS-232	Internally generated positive RS-232 transmitter supply (+5.5V). C3 not needed in RS-485 Mode.
V-	RS-232	Internally generated negative RS-232 transmitter supply (-5.5V). C4 not needed in RS-485 Mode.

Typical Operating Circuits

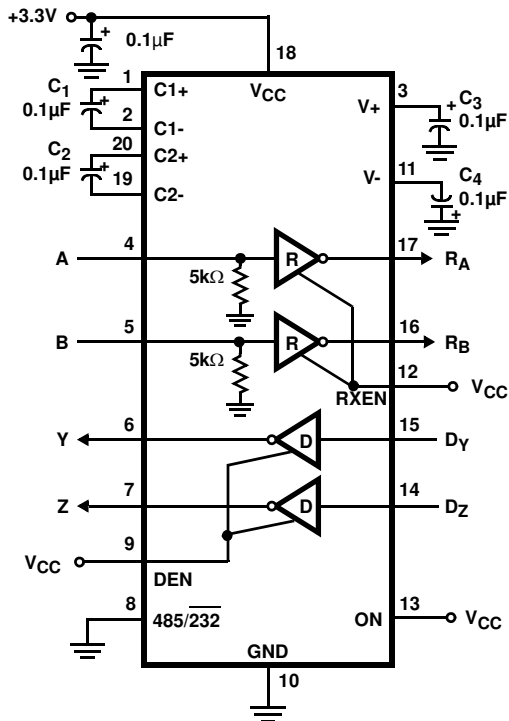

NOTE: PINOUT FOR SSOP  
RS-232 MODE WITHOUT LOOPBACK

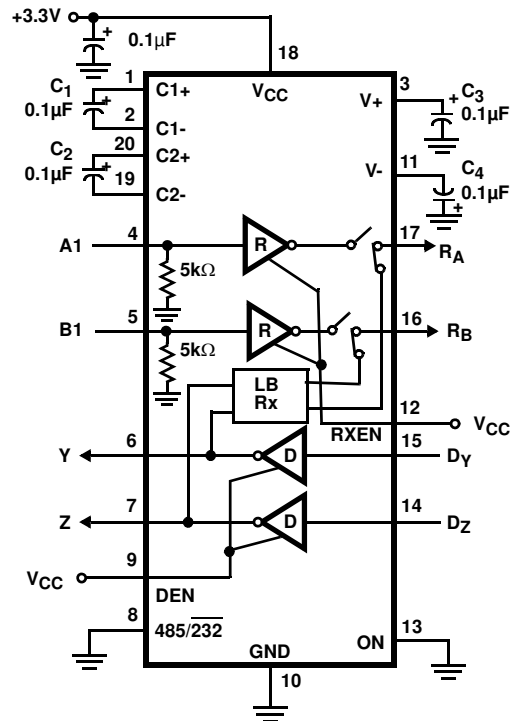

NOTE: PINOUT FOR SSOP  
RS-232 MODE WITH LOOPBACK

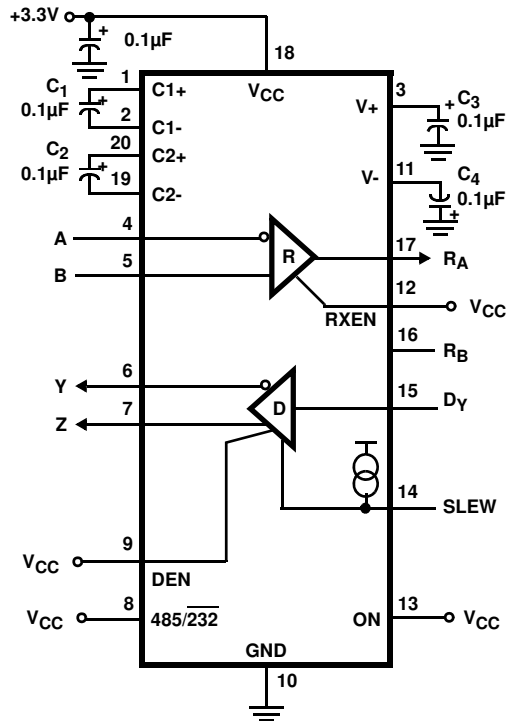

NOTE: PINOUT FOR SSOP  
RS-485 MODE WITHOUT LOOPBACK

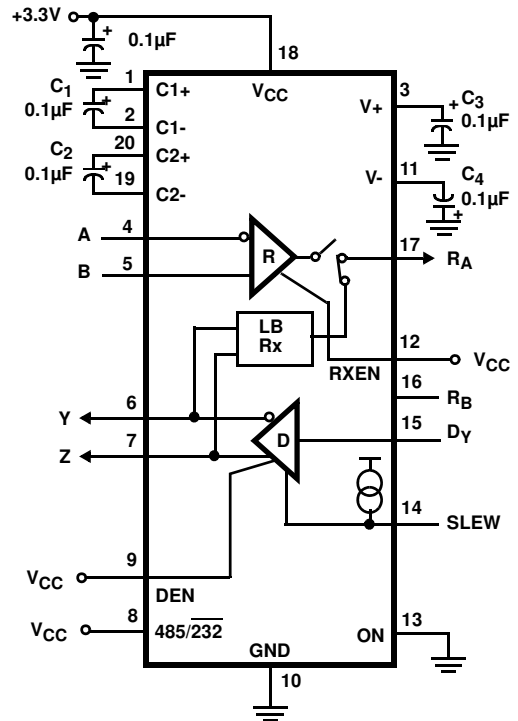

NOTE: PINOUT FOR SSOP  
RS-485 MODE WITH LOOPBACK

**Absolute Maximum Ratings** ( $T_A = +25^{\circ}\text{C}$ )

$V_{CC}$ to Ground	7V
$V_L$ (QFN Only)	-0.5V to $V_{CC} + 0.5V$
Input Voltages	
All Except A,B	-0.5V to 7V
Input/Output Voltages	
A, B (Any Mode)	-25V to +25V
Y, Z (Any Mode, Note 5)	-12.5V to +12.5V
$R_A, R_B$ (Non-QFN Package)	-0.5V to ( $V_{CC} + 0.5V$ )
$R_A, R_B$ (QFN Package)	-0.5V to ( $V_L + 0.5V$ )
Output Short Circuit Duration	
Y, Z, $R_A, R_B$	Indefinite
ESD Rating	See Specification Table

**Thermal Information**

Thermal Resistance (Typical)	$\theta_{JA}$ ( $^{\circ}\text{C}/\text{W}$ )	$\theta_{JC}$ ( $^{\circ}\text{C}/\text{W}$ )
20 Ld SSOP Package (Note 6)	55	N/A
40 Ld QFN Package (Notes 7, 8)	31	2.5
Maximum Junction Temperature (Plastic Package)	+150 $^{\circ}\text{C}$	
Maximum Storage Temperature Range	-65 $^{\circ}\text{C}$ to +150 $^{\circ}\text{C}$	
Pb-free reflow profile	see link below	
	<a href="http://www.intersil.com/pbfree/Pb-FreeReflow.asp">http://www.intersil.com/pbfree/Pb-FreeReflow.asp</a>	

**Operating Conditions**

Temperature Range	-40 $^{\circ}\text{C}$ to +85 $^{\circ}\text{C}$
-------------------	--

*CAUTION: Do not operate at or near the maximum ratings listed for extended periods of time. Exposure to such conditions may adversely impact product reliability and result in failures not covered by warranty.*

**NOTES:**

- One output at a time,  $I_{OUT} \leq 100\text{mA}$  for  $\leq 10$  minutes.
- $\theta_{JA}$  is measured with the component mounted on a high effective thermal conductivity test board in free air. See Tech Brief TB379 for details.
- $\theta_{JA}$  is measured in free air with the component mounted on a high effective thermal conductivity test board with "direct attach" features. See Tech Brief TB379.
- For  $\theta_{JC}$ , the "case temp" location is the center of the exposed metal pad on the package underside.

**Electrical Specifications** Test Conditions:  $V_{CC} = 3.15V$  to  $3.45V$ ,  $C_1$  to  $C_4 = 0.1\mu\text{F}$ ,  $V_L = V_{CC}$  (for QFN only), Unless Otherwise Specified. Typical values are at  $V_{CC} = 3.3V$ ,  $T_A = +25^{\circ}\text{C}$  (Note 9)

PARAMETER	SYMBOL	TEST CONDITIONS	TEMP ( $^{\circ}\text{C}$ )	MIN (Note 15)	TYP	MAX (Note 15)	UNITS	
<b>DC CHARACTERISTICS - RS-485 DRIVER (485/232 = <math>V_{CC}</math>)</b>								
Driver Differential $V_{OUT}$ (no load)	$V_{OD1}$		Full	-	-	$V_{CC}$	V	
Driver Differential $V_{OUT}$ (with load)	$V_{OD2}$	$R = 50\Omega$ (RS-422) (Figure 1)	Full	2	2.3	-	V	
		$R = 27\Omega$ (RS-485) (Figure 1)	Full	1.5	2	5	V	
	$V_{OD3}$	$R_D = 60\Omega$ , $R = 375\Omega$ , $V_{CM} = -7V$ to $12V$ (Figure 1)	Full	1.5	-	5	V	
Change in Magnitude of Driver Differential $V_{OUT}$ for Complementary Output States	$\Delta V_{OD}$	$R = 27\Omega$ or $50\Omega$ (Figure 1)	Full	-	0.01	0.2	V	
Driver Common-Mode $V_{OUT}$	$V_{OC}$	$R = 27\Omega$ or $50\Omega$ (Figure 1)	Full	-	-	3.0	V	
Change in Magnitude of Driver Common-Mode $V_{OUT}$ for Complementary Output States	$\Delta V_{OC}$	$R = 27\Omega$ or $50\Omega$ (Figure 1)	Full	-	0.01	0.2	V	
Driver Short-Circuit Current, $V_{OUT} = \text{High or Low}$	$I_{OS}$	$-7V \leq (V_Y \text{ or } V_Z) \leq 12V$ (Note 11)	Full	35	-	250	mA	
Driver Three-State Output Leakage Current (Y, Z)	$I_{OZ}$	Outputs Disabled, $V_{CC} = 0V$ or $3.45V$	$V_{OUT} = 12V$	Full	-	-	150	$\mu\text{A}$
			$V_{OUT} = -7V$	Full	-150	-	-	$\mu\text{A}$
<b>DC CHARACTERISTICS - RS-232 DRIVER (485/232 = <math>0V</math>)</b>								
Driver Output Voltage Swing	$V_O$	All $T_{OUTS}$ Loaded with $3k\Omega$ to Ground	Full	$\pm 5.0$	-	-	V	
Driver Output Short-Circuit Current	$I_{OS}$	$V_{OUT} = 0V$	Full	-60	-	60	mA	
<b>DC CHARACTERISTICS - LOGIC PINS (i.e., DRIVER AND CONTROL INPUT PINS)</b>								
Input High Voltage	$V_{IH1}$	$V_L = V_{CC}$ if QFN	Full	2.2		-	V	
	$V_{IH2}$	$2.7V \leq V_L < 3.0V$ (QFN Only)	Full	2		-	V	
	$V_{IH3}$	$2.3V \leq V_L < 2.7V$ (QFN Only)	Full	1.6		-	V	
	$V_{IH4}$	$1.6V \leq V_L < 2.3V$ (QFN Only)	Full	$0.7 \cdot V_L$		-	V	
	$V_{IH5}$	$1.2V \leq V_L < 1.6V$ (QFN Only)	25	-	$0.7 \cdot V_L$	-	V	



# ISL3330, ISL3331

**Electrical Specifications** Test Conditions:  $V_{CC} = 3.15V$  to  $3.45V$ ,  $C_1$  to  $C_4 = 0.1\mu F$ ,  $V_L = V_{CC}$  (for QFN only), Unless Otherwise Specified. Typical values are at  $V_{CC} = 3.3V$ ,  $T_A = +25^\circ C$  (Note 9) (Continued)

PARAMETER	SYMBOL	TEST CONDITIONS	TEMP (°C)	MIN (Note 15)	TYP	MAX (Note 15)	UNITS	
Input Low Voltage	$V_{IL1}$	$V_L = V_{CC}$ if QFN	Full	-	-	0.8	V	
	$V_{IL2}$	$V_L \geq 2.7V$ (QFN Only)	Full	-	-	0.8	V	
	$V_{IL3}$	$2.3V \leq V_L < 2.7V$ (QFN Only)	Full	-	-	0.7	V	
	$V_{IL4}$	$1.6V \leq V_L < 2.3V$ (QFN Only)	Full	-	-	$0.35 \cdot V_L$	V	
	$V_{IL5}$	$1.3V \leq V_L < 1.6V$ (QFN Only)	25	-	$0.35 \cdot V_L$	-	V	
	$V_{IL6}$	$1.2V \leq V_L < 1.3V$ (QFN Only)	25	-	$0.25 \cdot V_L$	-	V	
Input Current	$I_{IN1}$	Except SLEW, $\overline{RXEN}$ (QFN), and SPB (QFN)	Full	-2	-	2	$\mu A$	
	$I_{IN2}$	SLEW (Note 13), $\overline{RXEN}$ (QFN), and SPB (QFN)	Full	-25	-	25	$\mu A$	
<b>DC CHARACTERISTICS - RS-485 RECEIVER INPUTS (485/232 = <math>V_{CC}</math>)</b>								
Receiver Differential Threshold Voltage	$V_{TH}$	$-7V \leq V_{CM} \leq 12V$ , Full Failsafe	Full	-0.2	-	-0.04	V	
Receiver Input Hysteresis	$\Delta V_{TH}$	$V_{CM} = 0V$	25	-	35	-	mV	
Receiver Input Current (A, B)	$I_{IN}$	$V_{CC} = 0V$ or $3.15V$ to $3.45V$	$V_{IN} = 12V$	Full	-	-	0.8	mA
			$V_{IN} = -7V$	Full	-0.64	-	-	mA
Receiver Input Resistance	$R_{IN}$	$-7V \leq V_{CM} \leq 12V$ , $V_{CC} = 0$ (Note 12), or $3.15V \leq V_{CC} \leq 3.45V$	Full	15	-	-	k $\Omega$	
<b>DC CHARACTERISTICS - RS-232 RECEIVER INPUTS (485/232 = GND)</b>								
Receiver Input Voltage Range	$V_{IN}$		Full	-25	-	25	V	
Receiver Input Threshold	$V_{IL}$		Full	-	1.1	0.8	V	
	$V_{IH}$		Full	2.4	1.6	-	V	
Receiver Input Hysteresis	$\Delta V_{TH}$		25	-	0.5	-	V	
Receiver Input Resistance	$R_{IN}$	$V_{IN} = \pm 15V$ , $V_{CC}$ Powered-Up (Note 12)	Full	3	5	7	k $\Omega$	
<b>DC CHARACTERISTICS - RECEIVER OUTPUTS (485 OR 232 MODE)</b>								
Receiver Output High Voltage	$V_{OH1}$	$I_O = -1.5mA$ ( $V_L = V_{CC}$ if QFN)	Full	$V_{CC} - 0.4$	-	-	V	
	$V_{OH2}$	$I_O = -100\mu A$ , $V_L \geq 1.2V$ (QFN Only)	Full	$V_L - 0.1$	-	-	V	
	$V_{OH3}$	$I_O = -500\mu A$ , $V_L = 1.5V$ (QFN Only)	Full	1.2	-	-	V	
	$V_{OH4}$	$I_O = -150\mu A$ , $V_L = 1.2V$ (QFN Only)	Full	1.0	-	-	V	
Receiver Output Low Voltage	$V_{OL}$	$I_O = 5mA$	Full	-	0.2	0.4	V	
Receiver Short-Circuit Current	$I_{OSR}$	$0V \leq V_O \leq V_{CC}$	Full	7	-	85	mA	
Receiver Three-State Output Current	$I_{OZR}$	Output Disabled, $0V \leq V_O \leq V_{CC}$ (or $V_L$ for QFN)	Full	-	-	$\pm 10$	$\mu A$	
<b>POWER SUPPLY CHARACTERISTICS</b>								
No-Load Supply Current (Note 10)	$I_{CC232}$	485/232 = 0V, ON = $V_{CC}$	Full	-	3.7	7	mA	
	$I_{CC485}$	485/232 = $V_{CC}$ , ON = $V_{CC}$	Full	-	1.3	5	mA	
Shutdown Supply Current	$I_{SHDN232}$	ON = DEN = $\overline{RXEN} = 0V$ ( $\overline{RXEN} = SPB = V_L$ if QFN)	Full	-	10	30	$\mu A$	
	$I_{SHDN485}$	ON = DEN = $\overline{RXEN} = SLEW = 0V$ ( $\overline{RXEN} = V_L$ , SPB = 0V if QFN)	Full	-	30	60	$\mu A$	
<b>ESD CHARACTERISTICS</b>								
Bus Pins (A, B, Y, Z) Any Mode		Human Body Model	25	-	$\pm 15$	-	kV	
All Other Pins		Human Body Model	25	-	$\pm 2.5$	-	kV	
		Machine Model	25	-	$\pm 200$	-	V	

# ISL3330, ISL3331

**Electrical Specifications** Test Conditions:  $V_{CC} = 3.15V$  to  $3.45V$ ,  $C_1$  to  $C_4 = 0.1\mu F$ ,  $V_L = V_{CC}$  (for QFN only), Unless Otherwise Specified. Typical values are at  $V_{CC} = 3.3V$ ,  $T_A = +25^\circ C$  (Note 9) **(Continued)**

PARAMETER	SYMBOL	TEST CONDITIONS	TEMP (°C)	MIN (Note 15)	TYP	MAX (Note 15)	UNITS	
<b>RS-232 DRIVER and RECEIVER SWITCHING CHARACTERISTICS (485/232 = 0V, ALL VERSIONS AND SPEEDS)</b>								
Driver Output Transition Region Slew Rate	SR	$R_L = 3k\Omega$ , Measured From 3V to -3V or -3V to 3V	$C_L \geq 15pF$	Full	-	20	30	V/ $\mu s$
			$C_L \leq 2500pF$	Full	4	12	-	V/ $\mu s$
Driver Output Transition Time	$t_r, t_f$	$R_L = 3k\Omega$ , $C_L = 2500pF$ , 10% to 90%	Full	0.22	1.2	3.1	$\mu s$	
Driver Propagation Delay	$t_{DPHL}$	$R_L = 3k\Omega$ , $C_L = 1000pF$ (Figure 6)	Full	-	1	2	$\mu s$	
	$t_{DPLH}$		Full	-	1.2	2	$\mu s$	
Driver Propagation Delay Skew	$t_{DSKEW}$	$t_{DPHL} - t_{DPLH}$ (Figure 6)	Full	-	300	450	ns	
Driver Enable Time	$t_{DEN}$		25	-	1200	-	ns	
Driver Disable Time	$t_{DDIS}$	$R_L = 5k\Omega$ , Measured at $V_{OUT} = \pm 3V$	25	-	500	-	ns	
Driver Enable Time from Shutdown	$t_{DENSD}$	$V_{OUT} = \pm 3.0V$ (Note 14)	25	-	25	-	$\mu s$	
Driver Maximum Data Rate	$DR_D$	$R_L = 3k\Omega$ , $C_L = 1000pF$ , One Transmitter Switching	Full	250	400	-	kbps	
Receiver Propagation Delay	$t_{RPHL}$	$C_L = 15pF$ (Figure 7)	Full	-	40	120	ns	
	$t_{RPLH}$		Full	-	60	120	ns	
Receiver Propagation Delay Skew	$t_{RSKEW}$	$t_{RPHL} - t_{RPLH}$ (Figure 7)	Full	-	20	40	ns	
Receiver Maximum Data Rate	$DR_R$	$C_L = 15pF$	Full	0.46	2	-	Mbps	
Receiver Enable to Output Low	$t_{ZL}$	$C_L = 15pF$ , SW = $V_{CC}$ (Figure 5)	Full	-	18	-	ns	
Receiver Enable to Output High	$t_{ZH}$	$C_L = 15pF$ , SW = GND (Figure 5)	Full	-	18	-	ns	
Receiver Disable from Output Low	$t_{LZ}$	$C_L = 15pF$ , SW = $V_{CC}$ (Figure 5)	Full	-	22	-	ns	
Receiver Disable from Output High	$t_{HZ}$	$C_L = 15pF$ , SW = GND (Figure 5)	Full	-	22	-	ns	
Receiver Enable from Shutdown to Output Low	$t_{ZLSHDN}$	$C_L = 15pF$ , SW = $V_{CC}$ (Figure 5, Note 14)	25	-	60	-	ns	
Receiver Enable from Shutdown to Output High	$t_{ZHSHDN}$	$C_L = 15pF$ , SW = GND (Figure 5, Note 14)	25	-	20	-	ns	
<b>RS-485 DRIVER SWITCHING CHARACTERISTICS (FAST DATA RATE (20Mbps), 485/232 = <math>V_{CC}</math>, SLEW = <math>V_{CC}</math>, ALL VERSIONS)</b>								
Driver Differential Input to Output Delay	$t_{DLH}, t_{DHL}$	$R_{DIFF} = 54\Omega$ , $C_L = 100pF$ (Figure 2)	Full	10	20	35	ns	
Driver Output Skew	$t_{SKEW}$	$R_{DIFF} = 54\Omega$ , $C_L = 100pF$ (Figure 2)	Full	-	2	10	ns	
Driver Differential Rise or Fall Time	$t_R, t_F$	$R_{DIFF} = 54\Omega$ , $C_L = 100pF$ (Figure 2)	Full	3	20	30	ns	
Driver Enable to Output Low	$t_{ZL}$	$C_L = 100pF$ , SW = $V_{CC}$ (Figure 3)	Full	-	28	60	ns	
Driver Enable to Output High	$t_{ZH}$	$C_L = 100pF$ , SW = GND (Figure 3)	Full	-	39	60	ns	
Driver Disable from Output Low	$t_{LZ}$	$C_L = 15pF$ , SW = $V_{CC}$ (Figure 3)	Full	-	30	60	ns	
Driver Disable from Output High	$t_{HZ}$	$C_L = 15pF$ , SW = GND (Figure 3)	Full	-	25	60	ns	
Driver Enable from Shutdown to Output Low	$t_{ZL(SHDN)}$	$R_L = 500\Omega$ , $C_L = 100pF$ , SW = $V_{CC}$ (Figure 3, Note 14)	Full	-	100	250	ns	
Driver Enable from Shutdown to Output High	$t_{ZH(SHDN)}$	$R_L = 500\Omega$ , $C_L = 100pF$ , SW = GND (Figure 3, Note 14)	Full	-	290	375	ns	
Driver Maximum Data Rate	$f_{MAX}$	$R_{DIFF} = 54\Omega$ , $C_L = 100pF$ (Figure 2)	Full	20	35	-	Mbps	
<b>RS-485 DRIVER SWITCHING CHARACTERISTICS (MEDIUM DATA RATE (460kbps), 485/232 = <math>V_{CC}</math>, SLEW = 0V, SPB (QFN Only) = <math>V_{CC}</math>, ALL VERSIONS)</b>								
Driver Differential Input to Output Delay	$t_{DLH}, t_{DHL}$	$R_{DIFF} = 54\Omega$ , $C_L = 100pF$ (Figure 2)	Full	200	500	1000	ns	
Driver Output Skew	$t_{SKEW}$	$R_{DIFF} = 54\Omega$ , $C_L = 100pF$ (Figure 2)	Full	-	10	150	ns	
Driver Differential Rise or Fall Time	$t_R, t_F$	$R_{DIFF} = 54\Omega$ , $C_L = 100pF$ (Figure 2)	Full	300	660	1100	ns	

# ISL3330, ISL3331

**Electrical Specifications** Test Conditions:  $V_{CC} = 3.15V$  to  $3.45V$ ,  $C_1$  to  $C_4 = 0.1\mu F$ ,  $V_L = V_{CC}$  (for QFN only), Unless Otherwise Specified. Typical values are at  $V_{CC} = 3.3V$ ,  $T_A = +25^\circ C$  (Note 9) (Continued)

PARAMETER	SYMBOL	TEST CONDITIONS	TEMP (°C)	MIN (Note 15)	TYP	MAX (Note 15)	UNITS
Driver Enable to Output Low	$t_{ZL}$	$C_L = 100pF$ , $SW = V_{CC}$ (Figure 3)	Full	-	42	100	ns
Driver Enable to Output High	$t_{ZH}$	$C_L = 100pF$ , $SW = GND$ (Figure 3)	Full	-	350	450	ns
Driver Disable from Output Low	$t_{LZ}$	$C_L = 15pF$ , $SW = V_{CC}$ (Figure 3)	Full	-	30	60	ns
Driver Disable from Output High	$t_{HZ}$	$C_L = 15pF$ , $SW = GND$ (Figure 3)	Full	-	25	60	ns
Driver Enable from Shutdown to Output Low	$t_{ZL}(SHDN)$	$R_L = 500\Omega$ , $C_L = 100pF$ , $SW = V_{CC}$ (Figure 3, Note 14)	Full	-	-	500	ns
Driver Enable from Shutdown to Output High	$t_{ZH}(SHDN)$	$R_L = 500\Omega$ , $C_L = 100pF$ , $SW = GND$ (Figure 3, Note 14)	Full	-	-	750	ns
Driver Maximum Data Rate	$f_{MAX}$	$R_{DIFF} = 54\Omega$ , $C_L = 100pF$ (Figure 2)	Full	460	2000	-	kbps
<b>RS-485 DRIVER SWITCHING CHARACTERISTICS (SLOW DATA RATE (115kbps, QFN ONLY), 485/232 = <math>V_{CC}</math>, SLEW = SPB = GND)</b>							
Driver Differential Input to Output Delay	$t_{DLH}$ , $t_{DHL}$	$R_{DIFF} = 54\Omega$ , $C_L = 100pF$ (Figure 2)	Full	800	1600	2500	ns
Driver Output Skew	$t_{SKEW}$	$R_{DIFF} = 54\Omega$ , $C_L = 100pF$ (Figure 2)	Full	-	250	500	ns
Driver Differential Rise or Fall Time	$t_R$ , $t_F$	$R_{DIFF} = 54\Omega$ , $C_L = 100pF$ (Figure 2)	Full	1000	1700	3100	ns
Driver Enable to Output Low	$t_{ZL}$	$C_L = 100pF$ , $SW = V_{CC}$ (Figure 3)	Full	-	45	100	ns
Driver Enable to Output High	$t_{ZH}$	$C_L = 100pF$ , $SW = GND$ (Figure 3)	Full	-	910	1200	ns
Driver Disable from Output Low	$t_{LZ}$	$C_L = 15pF$ , $SW = V_{CC}$ (Figure 3)	Full	-	35	60	ns
Driver Disable from Output High	$t_{HZ}$	$C_L = 15pF$ , $SW = GND$ (Figure 3)	Full	-	29	60	ns
Driver Enable from Shutdown to Output Low	$t_{ZL}(SHDN)$	$R_L = 500\Omega$ , $C_L = 100pF$ , $SW = V_{CC}$ (Figure 3, Note 14)	Full	-	-	800	ns
Driver Enable from Shutdown to Output High	$t_{ZH}(SHDN)$	$R_L = 500\Omega$ , $C_L = 100pF$ , $SW = GND$ (Figure 3, Note 14)	Full	-	-	1500	ns
Driver Maximum Data Rate	$f_{MAX}$	$R_{DIFF} = 54\Omega$ , $C_L = 100pF$ (Figure 2)	Full	115	800	-	kbps
<b>RS-485 RECEIVER SWITCHING CHARACTERISTICS (485/232 = <math>V_{CC}</math>, ALL VERSIONS AND SPEEDS)</b>							
Receiver Input to Output Delay	$t_{PLH}$ , $t_{PHL}$	(Figure 4)	Full	20	45	70	ns
Receiver Skew   $t_{PLH} - t_{PHL}$	$t_{SKEW}$	(Figure 4)	Full	-	3	10	ns
Receiver Maximum Data Rate	$f_{MAX}$		Full	20	40	-	Mbps
Receiver Enable to Output Low	$t_{ZL}$	$C_L = 15pF$ , $SW = V_{CC}$ (Figure 5)	Full	-	15	60	ns
Receiver Enable to Output High	$t_{ZH}$	$C_L = 15pF$ , $SW = GND$ (Figure 5)	Full	-	15	60	ns
Receiver Disable from Output Low	$t_{LZ}$	$C_L = 15pF$ , $SW = V_{CC}$ (Figure 5)	Full	-	20	60	ns
Receiver Disable from Output High	$t_{HZ}$	$C_L = 15pF$ , $SW = GND$ (Figure 5)	Full	-	20	60	ns
Receiver Enable from Shutdown to Output Low	$t_{ZLSHDN}$	$C_L = 15pF$ , $SW = V_{CC}$ (Figure 5, Note 14)	Full	-	500	900	ns
Receiver Enable from Shutdown to Output High	$t_{ZHSHDN}$	$C_L = 15pF$ , $SW = GND$ (Figure 5, Note 14)	Full	-	500	900	ns

**NOTES:**

- All currents into device pins are positive; all currents out of device pins are negative. All voltages are referenced to device ground unless otherwise specified.
- Supply current specification is valid for loaded drivers when  $DEN = 0V$ .
- Applies to peak current. See "Typical Performance Curves" beginning on page 19 for more information.
- $R_{IN}$  defaults to RS-485 mode ( $>15k\Omega$ ) when the device is unpowered ( $V_{CC} = 0V$ ), or in SHDN, regardless of the state of the 485/232 pin.
- The Slew pin has a pull-up resistor that enables only when in RS-485 mode ( $485/232 = V_{CC}$ ).
- ON, RXEN, and DEN all simultaneously switched Low-to-High.
- Parameters with MIN and/or MAX limits are 100% tested at  $+25^\circ C$ , unless otherwise specified. Temperature limits established by characterization and are not production tested.

Test Circuits and Waveforms

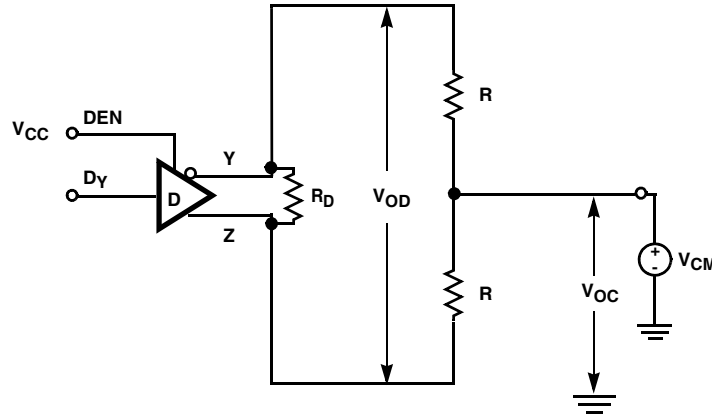

FIGURE 1. RS-485 DRIVER  $V_{OD}$  AND  $V_{OC}$  TEST CIRCUIT

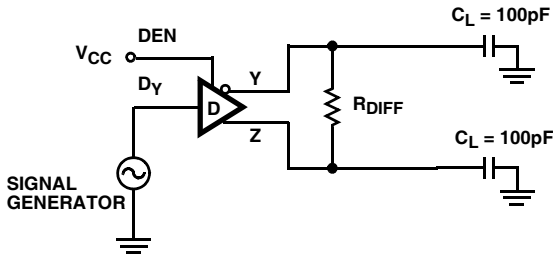
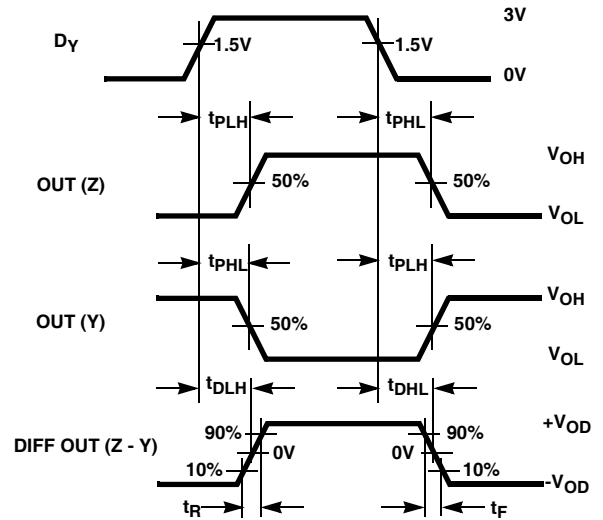

FIGURE 2A. TEST CIRCUIT

FIGURE 2. RS-485 DRIVER PROPAGATION DELAY AND DIFFERENTIAL TRANSITION TIMES



$$\text{SKEW} = |t_{PLH} (Y \text{ OR } Z) - t_{PLH} (Z \text{ OR } Y)|$$

FIGURE 2B. MEASUREMENT POINTS

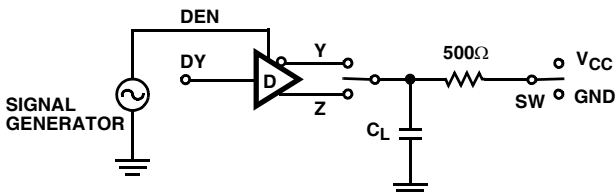

FOR SHDN TESTS, SWITCH ON AND DEN L- H SIMULTANEOUSLY

PARAMETER	OUTPUT	RXEN	DY	SW	$C_L$ (pF)
$t_{HZ}$	Y/Z	X	0/1	GND	15
$t_{LZ}$	Y/Z	X	1/0	$V_{CC}$	15
$t_{ZH}$	Y/Z	X	0/1	GND	100
$t_{ZL}$	Y/Z	X	1/0	$V_{CC}$	100
$t_{ZH}(\text{SHDN})$	Y/Z	0	0/1	GND	100
$t_{ZL}(\text{SHDN})$	Y/Z	0	1/0	$V_{CC}$	100

FIGURE 3A. TEST CIRCUIT

FIGURE 3. RS-485 DRIVER ENABLE AND DISABLE TIMES

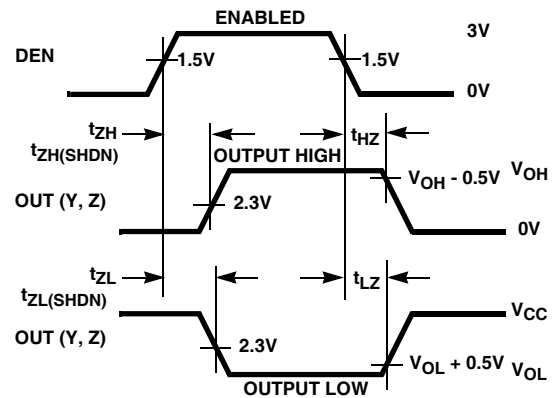

FIGURE 3B. MEASUREMENT POINTS

Test Circuits and Waveforms (Continued)

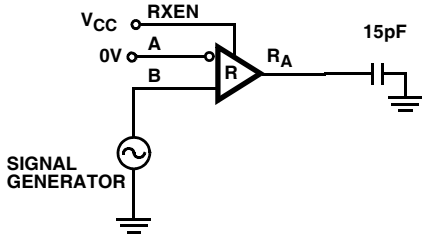

FIGURE 4A. TEST CIRCUIT

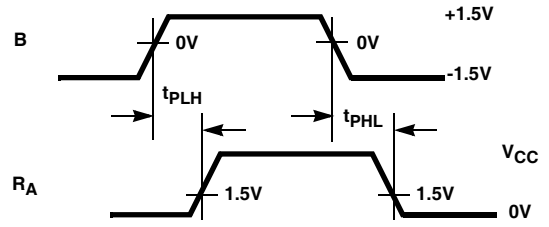
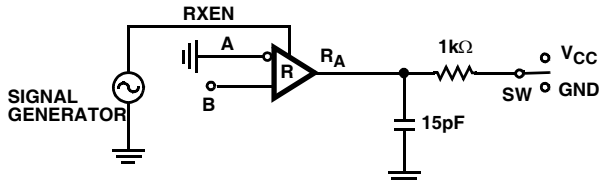

FIGURE 4B. MEASUREMENT POINTS

FIGURE 4. RS-485 RECEIVER PROPAGATION DELAY



FOR SHDN TESTS, SWITCH ON AND RXEN L- H SIMULTANEOUSLY

PARAMETER	DEN	B (V)	SW
$t_{HZ}$	X	+1.5	GND
$t_{LZ}$	X	-1.5	$V_{CC}$
$t_{ZH}$	X	+1.5	GND
$t_{ZL}$	X	-1.5	$V_{CC}$
$t_{ZH(SHDN)}$	0	+1.5	GND
$t_{ZL(SHDN)}$	0	-1.5	$V_{CC}$

FIGURE 5A. TEST CIRCUIT

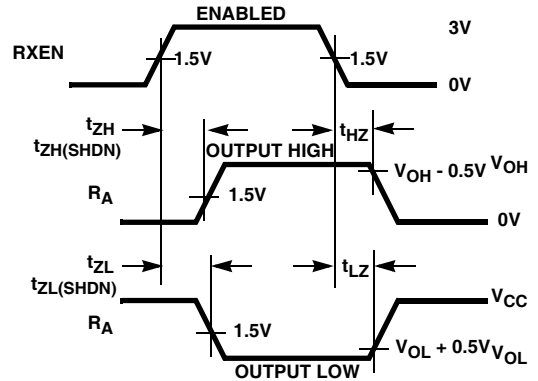

FIGURE 5B. MEASUREMENT POINTS

FIGURE 5. RS-485 RECEIVER ENABLE AND DISABLE TIMES

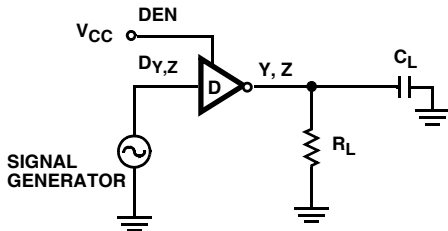

FIGURE 6A. TEST CIRCUIT

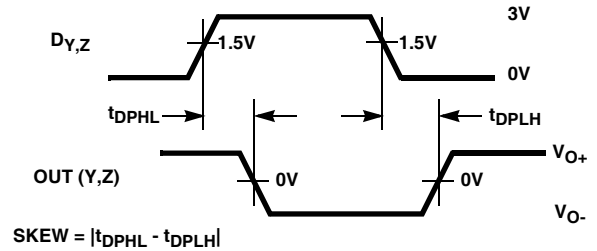

FIGURE 6B. MEASUREMENT POINTS

FIGURE 6. RS-232 DRIVER PROPAGATION DELAY

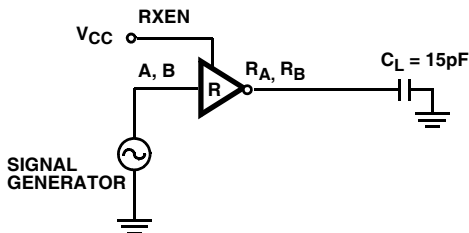

FIGURE 7A. TEST CIRCUIT

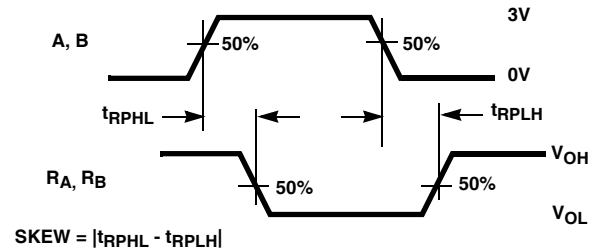

FIGURE 7B. MEASUREMENT POINTS

FIGURE 7. RS-232 RECEIVER PROPAGATION DELAY



**Detailed Description**

The ISL333x port supports dual protocols: RS-485/RS-422, and RS-232. RS-485 and RS-422 are differential (balanced) data transmission standards for use in high speed (up to 20Mbps) networks, or long haul and noisy environments. The differential signalling, coupled with RS-485's requirement for an extended common mode range (CMR) of +12V to -7V make these transceivers extremely tolerant of ground potential differences, as well as voltages induced in the cable by external fields. Both of these effects are real concerns when communicating over the RS-485/RS-422 maximum distance of 4000' (1220m). **It is important to note that the ISL333x don't follow the RS-485 convention whereby the inverting I/O is labeled "B/Z", and the non inverting I/O is "A/Y". Thus, in the application diagrams, see Figures 8 and 9, the 333x A/Y (B/Z) pins connect to the B/Z (A/Y) pins of the generic RS-485/RS-422 ICs.**

The RS-422 is typically a point-to-point (one driver talking to one receiver on a bus), or a point-to-multipoint (multidrop) standard that allows only one driver and up to 10 receivers on each bus. Because of the one driver per bus limitation,

RS-422 networks use a two bus, full duplex structure for bidirectional communication, and the Rx inputs and Tx outputs (no tri-state required) connect to different busses, as shown in Figure 9. The Tx and Rx enables aren't required, so connect RXEN and DEN to V<sub>CC</sub> through a 1kΩ resistor.

Conversely, RS-485 is a true multipoint standard, which allows up to 32 devices (any combination of drivers that must be tri-statable and receivers) on each bus. Now bidirectional communication takes place on a single bus, so the Rx inputs and Tx outputs of a port connect to the same bus lines, as shown in Figure 8. A port set to RS-485/RS-422 mode includes one Rx and one Tx. See Application Note AN1401 for details about implementing a three pin, selectable RS-232/half-duplex RS-485 port.

RS-232 is a point-to-point, singled ended (signal voltages referenced to GND) communication protocol targeting fairly short (< 150', 46m) and low data rate (<1Mbps) applications. A port contains two transceivers (2 Tx and 2 Rx) in RS-232 mode.

Protocol selection is handled via the 485/232 logic pin.

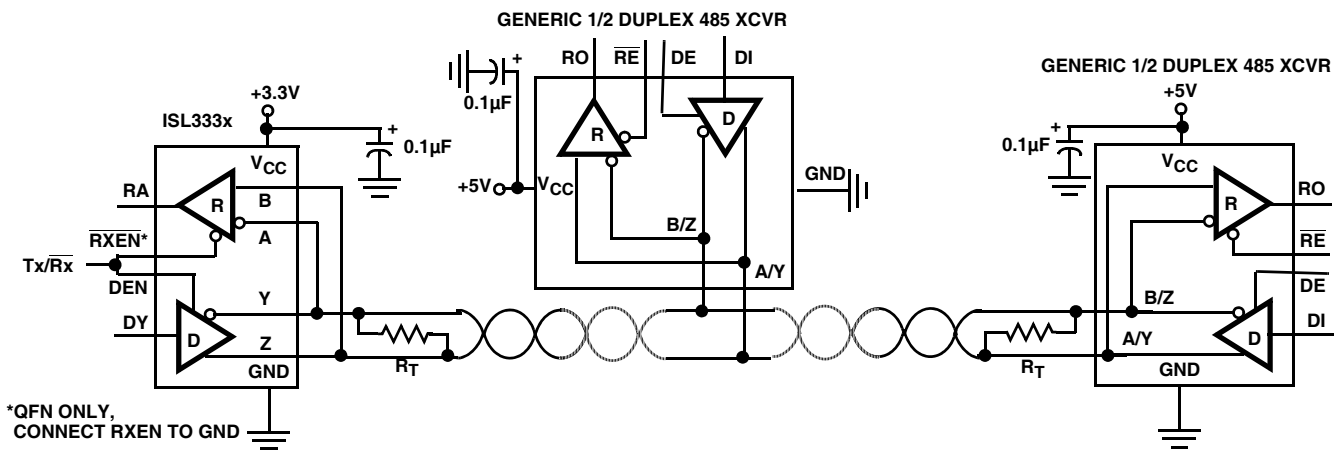

FIGURE 8. TYPICAL HALF DUPLEX RS-485 NETWORK

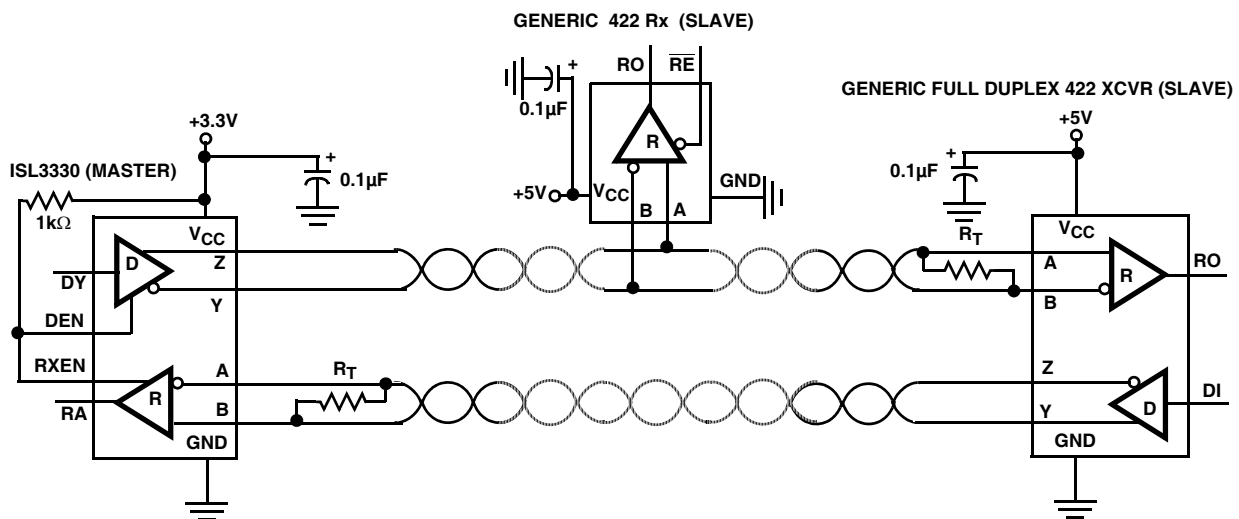

FIGURE 9. TYPICAL RS-422 NETWORK

### ISL333x Advantages

These dual protocol ICs offer many parametric improvements vs those offered on competing dual protocol devices. Some of the major improvements are:

- **3.3V Supply Voltage** - Eliminates the 5V supply that powers just the interface IC
- **15kV Bus Pin ESD** - Eases board level requirements
- **Full Failsafe RS-485 Rx** - Eliminates bus biasing
- **Selectable RS-485 Data Rate** - Up to 20Mbps, or slew rate limited for low EMI and fewer termination issues
- **High RS-232 Data Rate** - >250kbps
- **Lower Tx and Rx Skews** - Wider, consistent bit widths
- **Lower I<sub>CC</sub>** - Max I<sub>CC</sub> is 2x to -4x lower than competition
- **Flow-Thru Pinouts** - Tx, Rx bus pins on one side/logic pins on the other, for easy routing to connector/UART
- **Packaging** - Smaller (QFN) and Pb-free.

### RS-232 Mode

#### RX FEATURES

RS-232 receivers invert and convert RS-232 input levels ( $\pm 3V$  to  $\pm 25V$ ) to the standard TTL/CMOS levels required by a UART, ASIC, or  $\mu$ controller serial port. Receivers are designed to operate at faster data rates than the drivers, and they feature very low skews (20ns) so the receivers contribute negligibly to bit width distortion. Inputs include the standards required 3k $\Omega$  to 7k $\Omega$  pull-down resistor, so unused inputs may be left unconnected. Rx inputs also have built-in hysteresis to increase noise immunity and to decrease erroneous triggering due to slowly transitioning input signals.

Rx outputs are short circuit protected, and are tri-statable via the active high RXEN pin, when the IC is shutdown (SHDN; see Tables 2 and 3, and the “Low Power Shutdown (SHDN) Mode” on page 16), or via the active low  $\overline{\text{RXEN}}$  pin available on the QFN package option (see “ISL3331 (QFN Package) Special Features” on page 17).

#### TX FEATURES

RS-232 drivers invert and convert the standard TTL/CMOS levels from a UART, or  $\mu$ controller serial port to RS-232 compliant levels ( $\pm 5V$  minimum). The Tx delivers these compliant output levels even at data rates of 400kbps, and with loads of 1000pF. The drivers are designed for low skew (typically 12% of the 400kbps bit width), and are compliant to the RS-232 slew rate specification (4V to 30V/ $\mu$ s) for a wide range of load capacitances. Tx inputs float if left unconnected and may cause I<sub>CC</sub> increases. For the best results, connect unused inputs to GND.

Tx outputs are short circuit protected, and incorporate a thermal SHDN feature to protect the IC in situations of severe power dissipation. See the “RS-485 Mode” on page 14 for more details. Drivers disable via the active high

DEN pin, in SHDN (see Tables 2 and 3, and the “Low Power Shutdown (SHDN) Mode” on page 16), or when the 3.3V power supply is off. Because RS-232 is a point-to-point (only one Tx allowed on the bus) standard, the main use for this DEN disable function is to reduce power by eliminating the load current (approximately 1mA per Tx output) through the 5k $\Omega$  resistor in the Rx at the cable’s far end.

### CHARGE PUMPS

The on-chip charge pumps create the RS-232 transmitter power supplies (typically +5.7/-5.3V) from a single supply as low as 3.15V, and are enabled only if the port is configured for RS-232 operation, and not in SHDN. The efficient design requires only four small 0.1 $\mu$ F capacitors for the voltage doubler and inverter functions. By operating discontinuously (i.e., turning off as soon as V+ and V- pump up to the nominal values), the charge pump contribution to RS-232 mode I<sub>CC</sub> is reduced significantly. Unlike competing devices that require the charge pump in RS-485 mode, disabling the charge pump saves power, and minimizes noise. If the application is a dedicated RS-485 port, then the charge pump capacitors aren’t even required.

### DATA RATES AND CABLING

Drivers operate at data rates up to 400kbps, and are guaranteed for data rates up to 250kbps. The charge pumps and drivers are designed such that one driver can be operated at the rated load, and at 250kbps (see Figure 33). Figure 33 also shows that drivers can easily drive several thousands of picofarads at data rates up to 250kbps, while still delivering compliant  $\pm 5V$  output levels.

Receivers operate at data rates up to 2Mbps. They are designed for a higher data rate to facilitate faster factory downloading of software into the final product, thereby improving the user’s manufacturing throughput.

Figures 36 and 37 illustrate driver and receiver waveforms at 250kbps, and 400kbps, respectively. For these graphs, one driver drives the specified capacitive load, and a receiver.

RS-232 doesn’t require anything special for cabling; just a single bus wire per transmitter and receiver, and another wire for GND. So an ISL333x RS-232 port uses a five conductor cable for interconnection. Bus terminations are not required, nor allowed, by the RS-232 standard.

### RS-485 Mode

#### RX FEATURES

RS-485 receivers convert differential input signals as small as 200mV, as required by the RS-485 and RS-422 standards, to TTL/CMOS output levels. The differential Rx provides maximum sensitivity, noise immunity, and common mode rejection. Per the RS-485 standard, receiver inputs function with common mode voltages as great as +12V and -7V, regardless of supply voltage, making them ideal for long networks where induced voltages are a realistic concern.

Each RS-485/422 port includes a single receiver (RA), and the unused Rx output (RB) is disabled.

Worst case receiver input currents are 20% lower than the 1 “unit load” (1mA) RS-485 limit, which translates to a 15k $\Omega$  minimum input resistance.

These receivers include a “full fail-safe” function that guarantees a high level receiver output if the receiver inputs are unconnected (floating), shorted together, or if the bus is terminated but undriven (i.e., differential voltage collapses to near zero due to termination). Failsafe with shorted or terminated and undriven inputs is accomplished by setting the Rx upper switching point at -40mV, thereby ensuring that the Rx recognizes a 0V differential as a high level.

All the Rx outputs are short circuit protected, and are tri-statable via the active high RXEN pin, or when the IC is shutdown (see Tables 2 and 3, and the “Low Power Shutdown (SHDN) Mode” on page 16). ISL3331 (QFN) receiver outputs are also tri-statable via an active low  $\overline{\text{RXEN}}$  input (see “ISL3331 (QFN Package) Special Features” on page 17).

For the ISL3331 (QFN), when using the active high RXEN function, the RXEN pin may be left floating (internally pulled high), or should be connected to V<sub>CC</sub> through a 1k $\Omega$  resistor. If using the active low  $\overline{\text{RXEN}}$ , then the RXEN pin must be connected to GND.

**TX FEATURES**

The RS-485/RS-422 driver is a differential output device that delivers at least 1.5V across a 54 $\Omega$  load (RS-485), and at least 2V across a 100 $\Omega$  load (RS-422). The drivers feature low propagation delay skew to maximize bit widths, and to minimize EMI.

To allow multiple drivers on a bus, the RS-485 specification requires that drivers survive worst case bus contentions undamaged. The ISL333x drivers meet this requirement via driver output short circuit current limits, and on-chip thermal shutdown circuitry. The output stages incorporate current limiting circuitry that ensures that the output current never exceeds the RS-485 specification, even at the common mode voltage range extremes of 12V and -7V. In the event of a major short circuit condition, devices also include a thermal shutdown feature that disables the drivers whenever the die temperature becomes excessive. This eliminates the power dissipation, allowing the die to cool. The drivers automatically re-enable after the die temperature drops about +15°C. If the contention persists, the thermal shutdown/re-enable cycle repeats until the fault is cleared. Receivers stay operational during thermal shutdown.

The RS-485 multi-driver operation also requires drivers to include tri-state functionality, where the port has a DEN pin to control this function. If the driver is used in an RS-422 network, such that driver tri-state isn’t required, then the DEN pin should connect to V<sub>CC</sub> through a 1k $\Omega$  resistor.

Drivers are also tri-stated when the IC is in SHDN, or when the 3.3V power supply is off.

**SPEED OPTIONS**

The ISL3330 (SSOP) features two speed options that are user selectable via the SLEW pin: a high slew rate setting optimized for 20Mbps data rates (Fast), and a slew rate limited option for operation up to 460kbps (Med). The ISL3331 (QFN) offers an additional, more slew rate limited, option for data rates up to 115kbps (Slow). See the “Data Rate” and “RS-485 Slew Rate Limited Data Rates” on page 17 for more information.

Receiver performance is the same for all three speed options.

**DATA RATE, CABLES, AND TERMINATIONS**

RS-485/RS-422 are intended for network lengths up to 4000’ (1220m), but the maximum system data rate decreases as the transmission length increases. Devices operating at the maximum data rate of 20Mbps are limited to lengths of 20’ to 30’ (6m to 9m), while devices operating at or below 115kbps can operate at the maximum length of 4000’ (1220m).

Higher data rates require faster edges, so both the ISL333x versions offer an edge rate capable of 20Mbps data rates. They both have a second option for 460kbps, but the ISL3331 also offers another, very slew rate limited, edge rate to minimize problems at slow data rates. Nevertheless, for the best jitter performance when driving long cables, the faster speed settings may be preferable, even at low data rates. See the “RS-485 Slew Rate Limited Data Rates” on page 17 for details.

Twisted pair is the cable of choice for RS-485/RS-422 networks. Twisted pair cables tend to pick-up noise and other electromagnetically induced voltages as common mode signals, which are effectively rejected by the differential receivers in these ICs.

The preferred cable connection technique is “daisy-chaining”, where the cable runs from the connector of one device directly to the connector of the next device, such that cable stub lengths are negligible. A “backbone” structure, where stubs run from the main backbone cable to each device’s connector, is the next best choice, but care must be taken to ensure that each stub is electrically “short”. See Table 4 for recommended maximum stub lengths for each speed option.

**TABLE 4. RECOMMENDED STUB LENGTHS**

SPEED OPTION	MAXIMUM STUB LENGTH ft. (m)
SLOW	350 to 500 (107 to 152)
MED	100 to 150 (30.5 to 46)
FAST	1 to 3 (0.3 to 0.9)

Proper termination is imperative to minimize reflections when using the 20Mbps speed option. Short networks using the medium and slow speed options need not be terminated, but terminations are recommended unless power dissipation is an overriding concern. Note that the RS-485 specification allows a maximum of two terminations on a network, otherwise the Tx output voltage may not meet the required  $V_{OD}$ .

In point-to-point, or point-to-multipoint (RS-422) networks, the main cable should be terminated in its characteristic impedance (typically  $120\Omega$ ) at the end farthest from the driver. In multi-receiver applications, stubs connecting receivers to the main cable should be kept as short as possible, but definitely shorter than the limits shown in Table 4. Multipoint (RS-485) systems require that the main cable be terminated in its characteristic impedance at both ends. Again, keep stubs connecting a transceiver to the main cable as short as possible (refer to Table 4). Avoid “star”, and other configurations, where there are many “ends” which would require more than the two allowed terminations to prevent reflections.

### High ESD

All pins on the ISL333x include ESD protection structures rated at  $\pm 2.5kV$  (HBM), which is good enough to survive ESD events commonly seen during manufacturing. But the bus pins (Tx outputs and Rx inputs) are particularly vulnerable to ESD events because they connect to an exposed port on the exterior of the finished product. Simply touching the port pins, or connecting a cable, can destroy an unprotected port. ISL333x bus pins are fitted with advanced structures that deliver ESD protection in excess of  $\pm 15kV$  (HBM), without interfering with any signal in the RS-485 or the RS-232 range. This high level of protection may eliminate the need for board level protection, or at the very least will increase the robustness of any board level scheme.

### Small Packages

Competing 3.3V dual protocol ICs are available only in a 20 Ld or 24 Ld SSOP. The ISL3331's tiny 6mmx6mm QFN footprint is 36% to 44% smaller than the competing SSOPs.

### Flow-Through Pinouts

Even the ISL333x pinouts are features, in that the “flow-through” design simplifies board layout. Having the bus pins all on one side of the package for easy routing to a cable connector, and the Rx outputs and Tx inputs on the other side for easy connection to a UART, avoids costly and problematic crossovers. Figure 10 illustrates the flow-through nature of the pinout.

### Low Power Shutdown (SHDN) Mode

The ISL333x enter the SHDN mode when  $ON = 0$ , and the Tx and Rx are disabled ( $DEN = 0$ ,  $RXEN = 0$ , and  $\overline{RXEN} = 1$ ) and the already low supply current drops to as low as  $10\mu A$ . SHDN disables the Tx and Rx outputs, and

disables the charge pumps if the port is in RS-232 mode, so  $V_+$  collapses to  $V_{CC}$ , and  $V_-$  collapses to GND.

All but  $10\mu A$  of SHDN  $I_{CC}$  current is due to control input (SPB, SLEW) pull-up resistors ( $\sim 10\mu A/resistor$ ), so SHDN  $I_{CC}$  varies depending on the ISL333x configuration. The specification tables indicate the worst case values, but careful selection of the configuration yields lower currents. For example, in RS-232 mode the SPB pin isn't used, so floating it or tying it high minimizes SHDN  $I_{CC}$ .

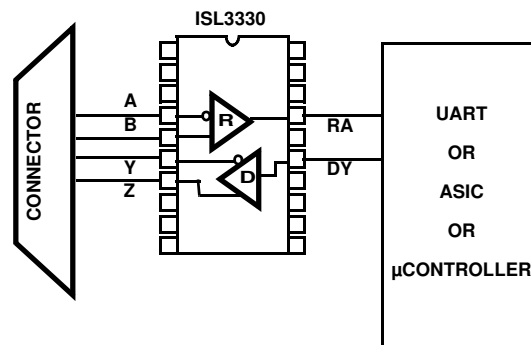

FIGURE 10. ILLUSTRATION OF FLOW-THROUGH PINOUT

When enabling from SHDN in RS-232 mode, allow at least  $25\mu s$  for the charge pumps to stabilize before transmitting data. If fast enables are required, and  $I_{CC}$  isn't the greatest concern, disable the drivers with the DEN pin to keep the charge pumps active. The charge pumps aren't used in RS-485 mode, thus the transceiver is ready to send or receive data in less than  $2\mu s$ , which is much faster than competing devices that require the charge pump for all modes of operation.

### Internal Loopback Mode

Setting  $ON = 0$ ,  $DEN = 1$ , and  $RXEN = 1$  or  $\overline{RXEN} = 0$  (QFN only), places the port in the loopback mode, a mode that facilitates implementing board level self test functions. In loopback, internal switches disconnect the Rx inputs from the Rx outputs, and feed back the Tx outputs to the appropriate Rx output. This way the data driven at the Tx input appears at the corresponding Rx output (refer to “Typical Operating Circuits” on page 6). The Tx outputs remain connected to their terminals, so the external loads are reflected in the loopback performance. This allows the loopback function to potentially detect some common bus faults such as one or both driver outputs shorted to GND, or outputs shorted together.

Note that the loopback mode uses an additional set of receivers, as shown in the “Typical Operating Circuits” on page 6. These loopback receivers are not standards compliant, so the loopback mode can't be used to implement a half-duplex RS-485 transceiver. See Application Note AN1401 for specific details on implementing a 3-pin, half duplex, dual protocol port.



**ISL3331 (QFN Package) Special Features**

**Logic Supply ( $V_L$  Pin)**

The ISL3331 (QFN) includes a  $V_L$  pin that powers the logic inputs (Tx inputs and control pins) and Rx outputs. These pins interface with “logic” devices such as UARTs, ASICs, and  $\mu$ controllers, and today many of these devices use power supplies significantly lower than 3.3V. Thus, a 3.3V output level from a 3.3V powered dual protocol IC might seriously overdrive and damage the logic device input. Similarly, the logic device’s low  $V_{OH}$  might not exceed the  $V_{IH}$  of a 3.3V powered dual protocol input. Connecting the  $V_L$  pin to the power supply of the logic device (as shown in Figure 11) limits the ISL3331’s Rx output  $V_{OH}$  to  $V_L$  (see Figure 14) and reduces the Tx and control input switching points to values compatible with the logic device output levels. Tailoring the logic pin input switching points and output levels to the supply voltage of the UART, ASIC, or  $\mu$ controller eliminates the need for a level shifter/translator between the two ICs.

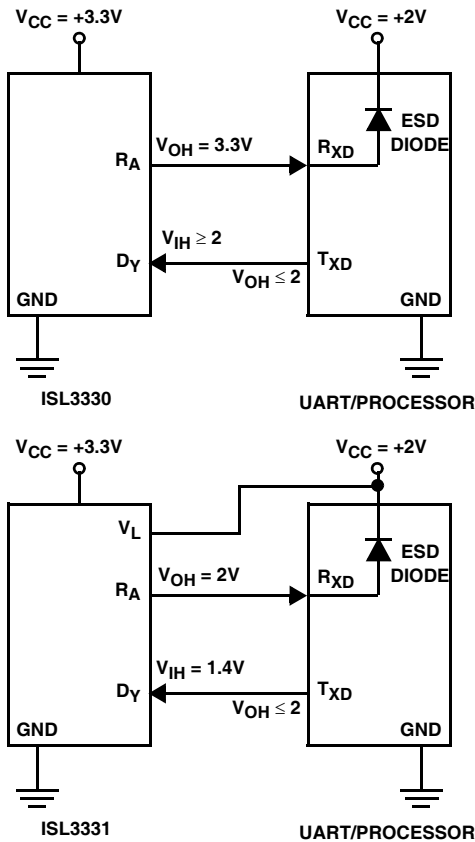

FIGURE 11. USING  $V_L$  PIN TO ADJUST LOGIC LEVELS

$V_L$  can be anywhere from  $V_{CC}$  down to 1.2V, but the input switching points may not provide enough noise margin when  $V_L < 1.5V$ . Table 5 indicates typical  $V_{IH}$  and  $V_{IL}$  values for various  $V_L$  voltages so the user can ascertain whether or not a particular  $V_L$  voltage meets his needs.

TABLE 5.  $V_{IH}$  AND  $V_{IL}$  vs  $V_L$  FOR  $V_{CC} = 3.3V$

$V_L$ (V)	$V_{IH}$ (V)	$V_{IL}$ (V)
1.2	0.85	0.26
1.5	0.9	0.5
1.8	0.9	0.73
2.3	1.2	1.0
2.7	1.4	1.3
3.3	1.8	1.7

Note: With  $V_L \leq 1.6V$ , the ISL3331 may not operate at the full data rate unless the logic signal  $V_{IL}$  is at least 0.2V below the typical value listed in Table 5.

The  $V_L$  supply current ( $I_L$ ) is typically less than 35 $\mu$ A, as shown in Figures 19 and 20. All of the DC  $V_L$  current is due to inputs with internal pull-up resistors (SPB, SLEW,  $\overline{RXEN}$ ) being driven to the low input state. The worst case  $I_L$  current occurs when all three of the inputs are low (see Figure 19), due to the  $I_L$  through the pull-up resistors.  $I_L$  through an input pull-up resistor is  $\sim 10\mu$ A, so the  $I_L$  in Figure 19 drops by about 18 $\mu$ A (at  $V_L = 3.3V$ ) when the SPB is high and 232 mode disables the SLEW pin pull-up (middle vs top curve). When all three inputs are driven high,  $I_L$  drops to  $\sim 10n$ A. Thus, to minimize power dissipation, drive these inputs high when unneeded (e.g., SPB isn’t used in RS-232 mode, so drive it high).

QFN logic input pins that are externally tied high in an application, should use the  $V_L$  supply for the high voltage level.

**Active Low Rx Enable ( $\overline{RXEN}$ )**

In many RS-485 applications, especially half duplex configurations, users like to accomplish “echo cancellation” by disabling the corresponding receiver while its driver is transmitting data. This function is available on the QFN package via an active low  $\overline{RXEN}$  pin. The active low function also simplifies direction control by allowing a single Tx/Rx direction control line. If the active high  $\overline{RXEN}$  were used, either two valuable I/O pins would be used for direction control, or an external inverter is required between DEN and  $\overline{RXEN}$ . Figure 12 details the advantage of using the  $\overline{RXEN}$  pin. When using  $\overline{RXEN}$ , ensure that  $\overline{RXEN}$  is tied to GND.

**RS-485 Slew Rate Limited Data Rates**

The ISL333x FAST speed option (SLEW = High) utilizes Tx output transitions optimized for a 20Mbps data rate. These fast edges may increase EMI and reflection issues, even though fast transitions aren’t required at the lower data rates used by many applications. With the SLEW pin low, both product types switch to a moderately slew rate limited output transition targeted for 460kbps (MED) data rates. The ISL3331 (QFN version), offers an additional slew rate limited data rate that is optimized for 115kbps (SLOW), and is selected when SLEW = 0 and SPB = 0 (see Table 3). The



slew limited edges permit longer unterminated networks, or longer stubs off terminated busses, and help minimize EMI and reflections. Nevertheless, for the best jitter performance when driving long cables, the faster speed options may be preferable, even at lower data rates. The faster output transitions deliver less variability (jitter) when loaded with the large capacitance associated with long cables. Of course, faster transitions require more attention to ensuring short stub lengths and quality terminations, so there are trade-offs to be made. Assuming a jitter budget of 10%, it is preferable to go with the slow speed option for data rates of 115kbps or less to minimize fast edge effects. Likewise, the medium speed option is a good choice for data rates between 115kbps and 460kbps. For higher data rates, or when the absolute best jitter is required, use the high speed option.

### Evaluation Board

An evaluation board, part number ISL3331EVAL1Z, is available to assist in assessing the dual protocol IC's performance. The evaluation board contains a QFN packaged device, but because the same die is used in all packages, the board is also useful for evaluating the functionality of the other versions. The board's design allows for evaluation of all standard features, plus the QFN specific features. Refer to the evaluation board application note for details, and contact your sales representative for ordering information.

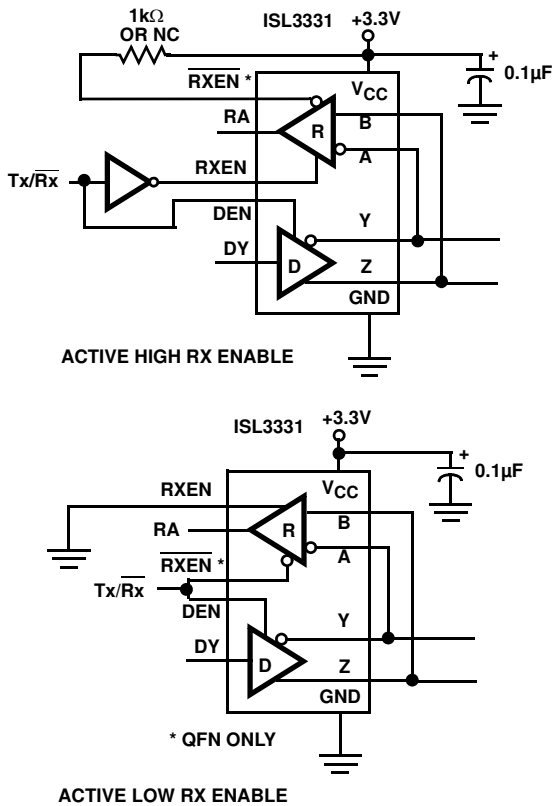

FIGURE 12. USING ACTIVE LOW vs ACTIVE HIGH RX ENABLE

**Typical Performance Curves**  $V_{CC} = V_L = 3.3V$ ,  $T_A = +25^\circ C$ ; Unless Otherwise Specified

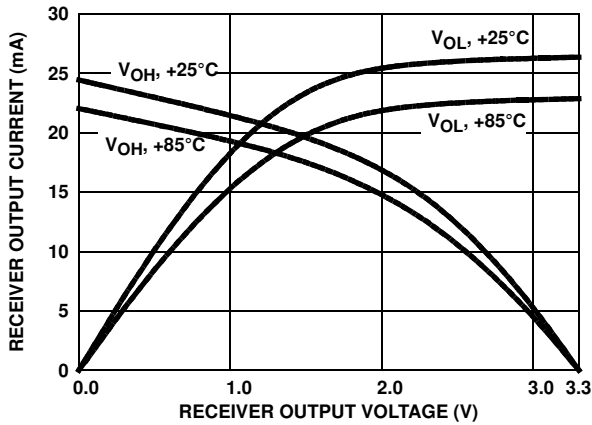

FIGURE 13. RECEIVER OUTPUT CURRENT vs RECEIVER OUTPUT VOLTAGE

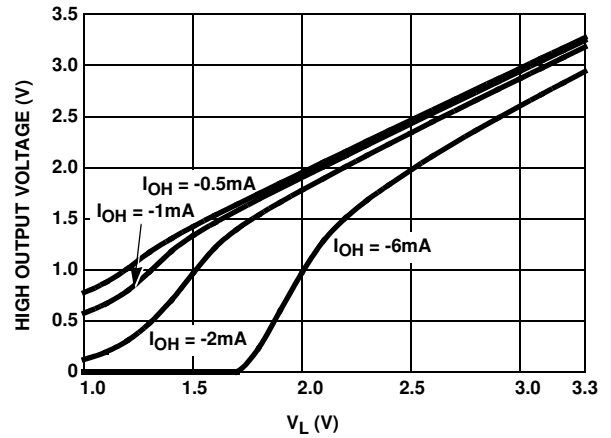

FIGURE 14. RECEIVER HIGH OUTPUT VOLTAGE vs LOGIC SUPPLY VOLTAGE ( $V_L$ ) (QFN ONLY)

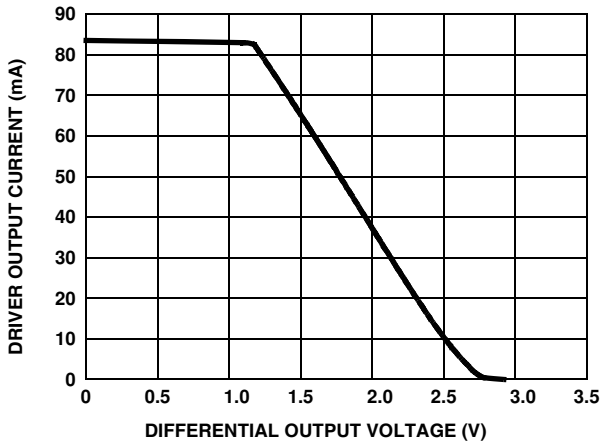

FIGURE 15. RS-485, DRIVER OUTPUT CURRENT vs DIFFERENTIAL OUTPUT VOLTAGE

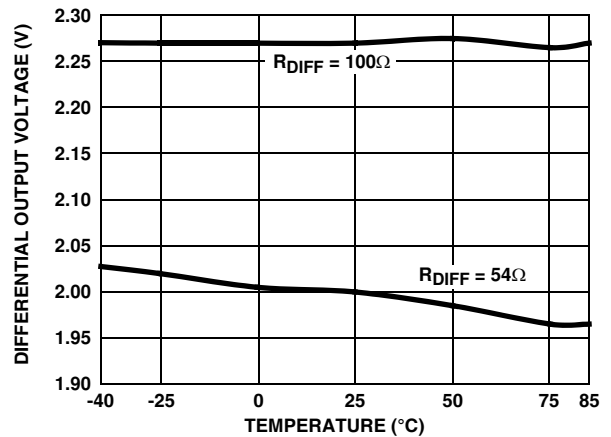

FIGURE 16. RS-485, DRIVER DIFFERENTIAL OUTPUT VOLTAGE vs TEMPERATURE

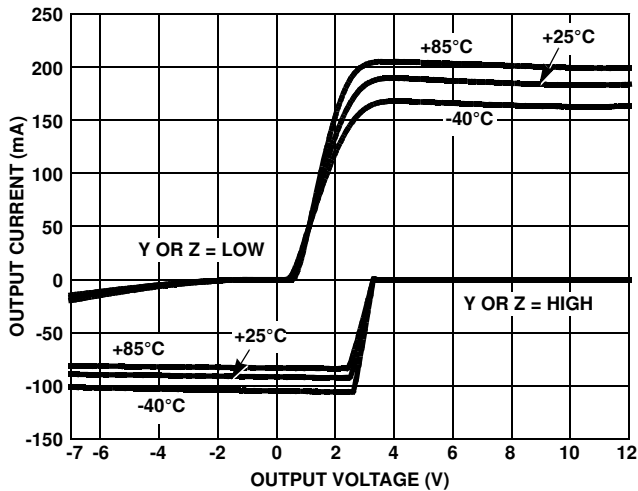

FIGURE 17. RS-485, DRIVER OUTPUT CURRENT vs SHORT CIRCUIT VOLTAGE

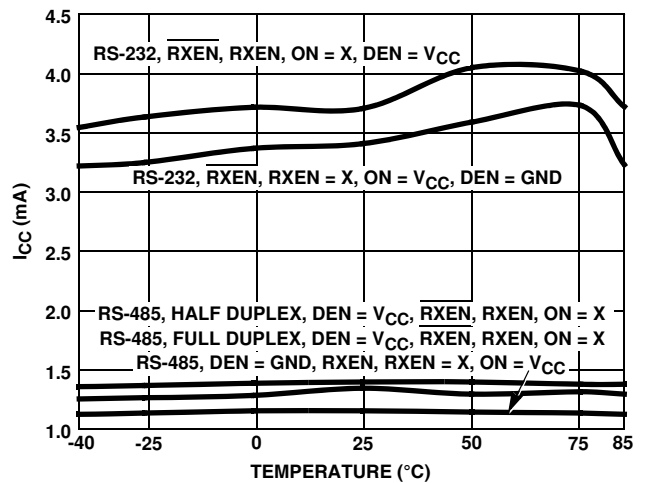

FIGURE 18. SUPPLY CURRENT vs TEMPERATURE

**Typical Performance Curves**  $V_{CC} = V_L = 3.3V$ ,  $T_A = +25^\circ C$ ; Unless Otherwise Specified (Continued)

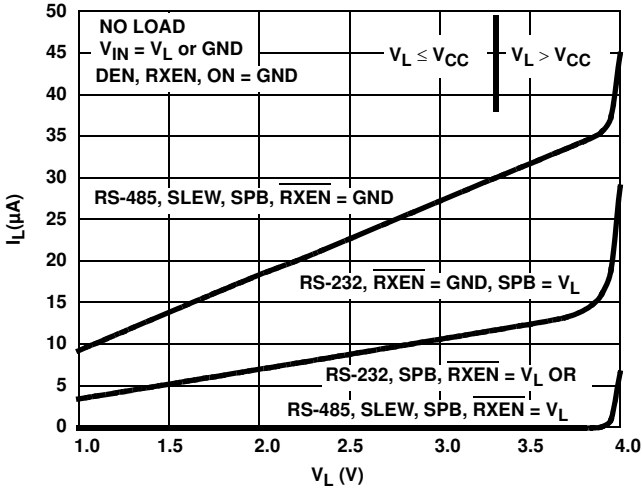

FIGURE 19. RS-232,  $V_L$  SUPPLY CURRENT vs  $V_L$  VOLTAGE (QFN ONLY)

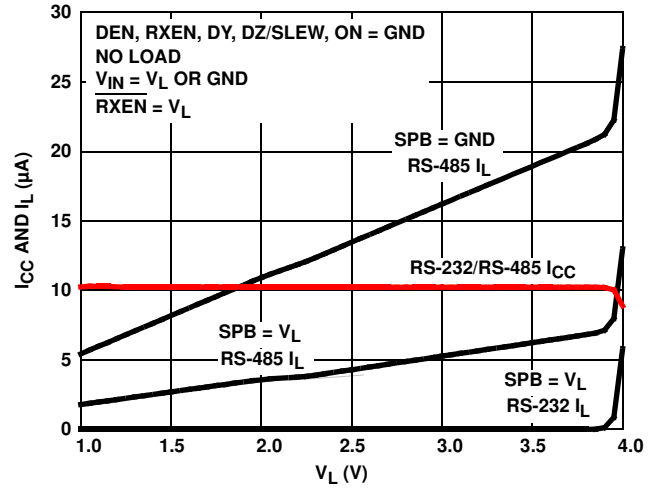

FIGURE 20.  $V_{CC}$  and  $V_L$  SHDN SUPPLY CURRENTS vs  $V_L$  VOLTAGE (QFN ONLY)

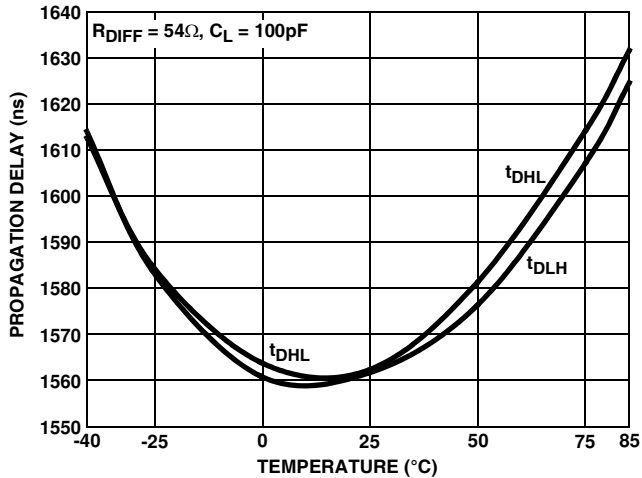

FIGURE 21. RS-485, DRIVER PROPAGATION DELAY vs TEMPERATURE (SLOW DATA RATE, QFN ONLY)

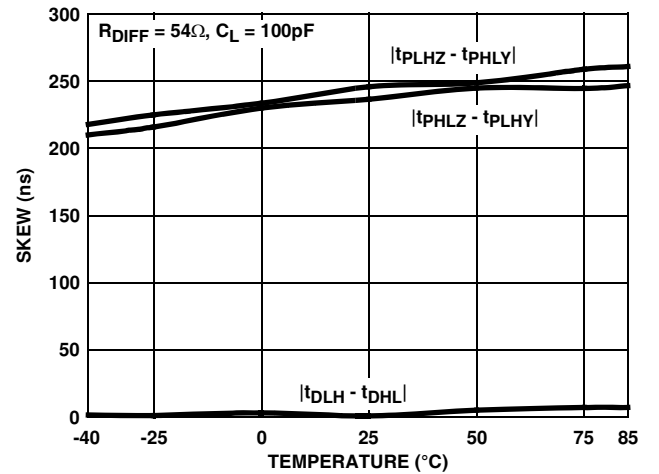

FIGURE 22. RS-485, DRIVER SKEW vs TEMPERATURE (SLOW DATA RATE, QFN ONLY)

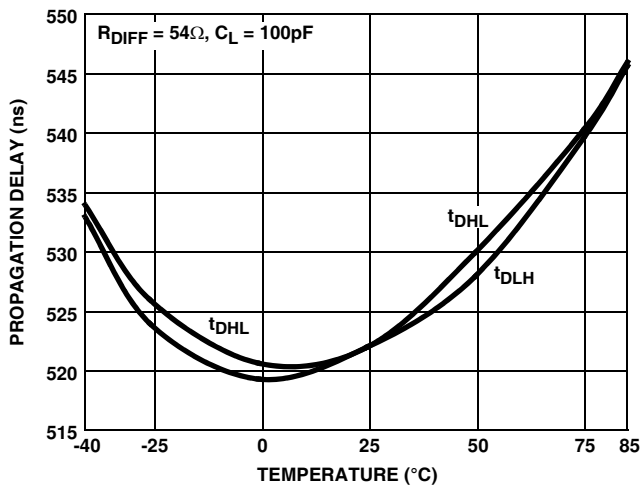

FIGURE 23. RS-485, DRIVER PROPAGATION DELAY vs TEMPERATURE (MEDIUM DATA RATE)

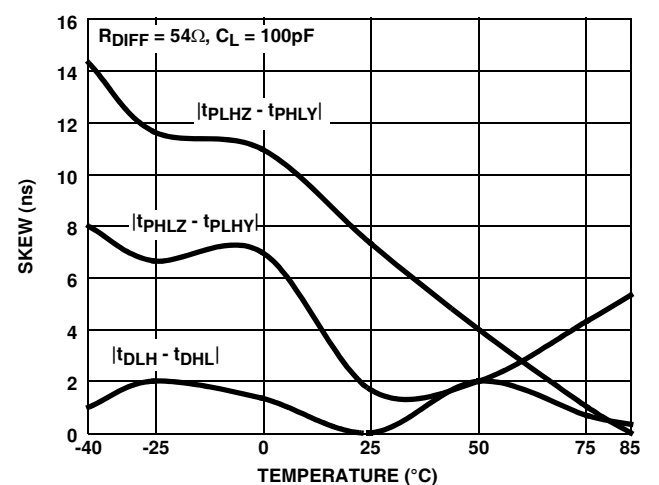

FIGURE 24. RS-485, DRIVER SKEW vs TEMPERATURE (MEDIUM DATA RATE)

**Typical Performance Curves**  $V_{CC} = V_L = 3.3V$ ,  $T_A = +25^\circ C$ ; Unless Otherwise Specified (Continued)

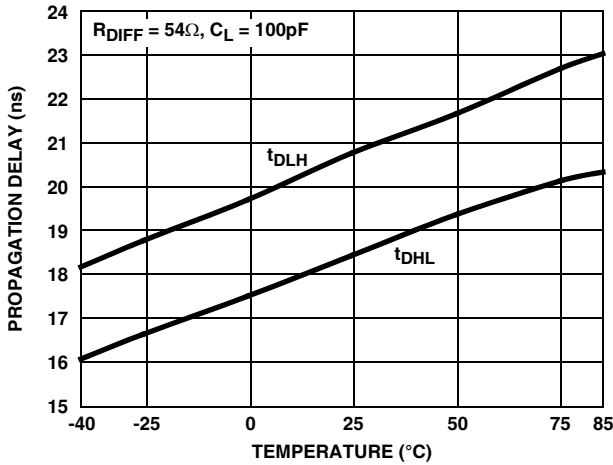

FIGURE 25. RS-485, DRIVER PROPAGATION DELAY vs TEMPERATURE (FAST DATA RATE)

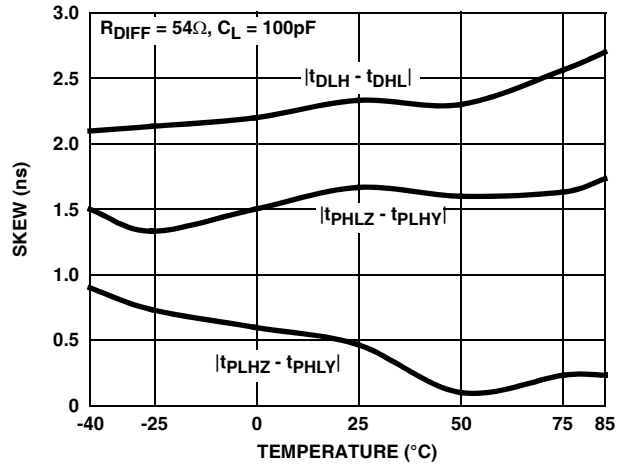

FIGURE 26. RS-485, DRIVER SKEW vs TEMPERATURE (FAST DATA RATE)

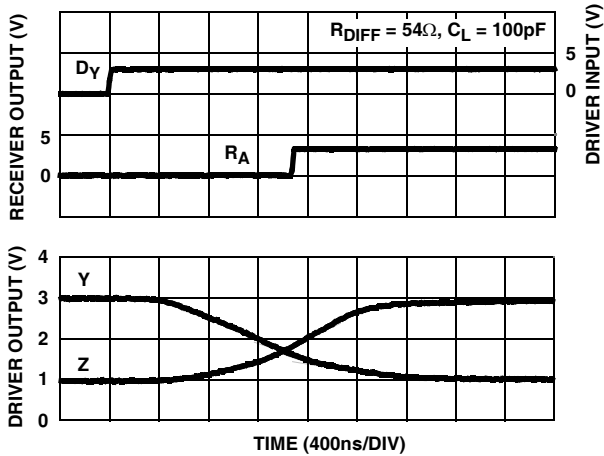

FIGURE 27. RS-485, DRIVER AND RECEIVER WAVEFORMS, LOW TO HIGH (SLOW DATA RATE, QFN ONLY)

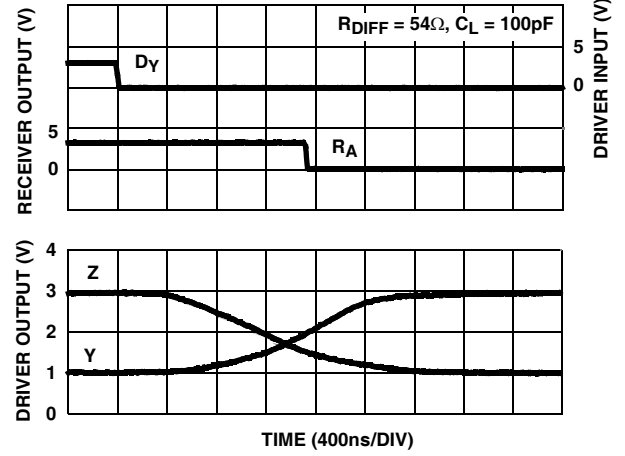

FIGURE 28. RS-485, DRIVER AND RECEIVER WAVEFORMS, HIGH TO LOW (SLOW DATA RATE, QFN ONLY)

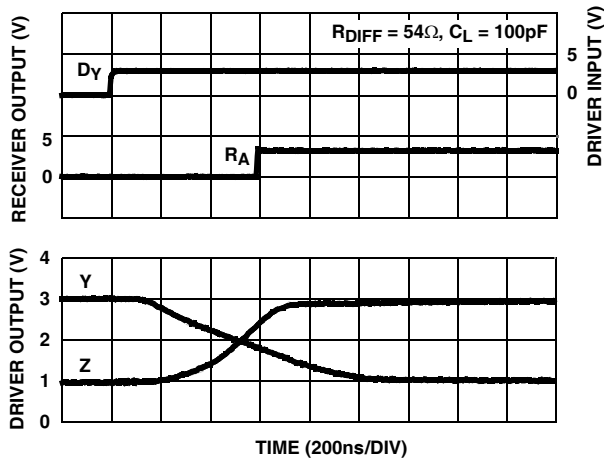

FIGURE 29. RS-485, DRIVER AND RECEIVER WAVEFORMS, LOW TO HIGH (MEDIUM DATA RATE)

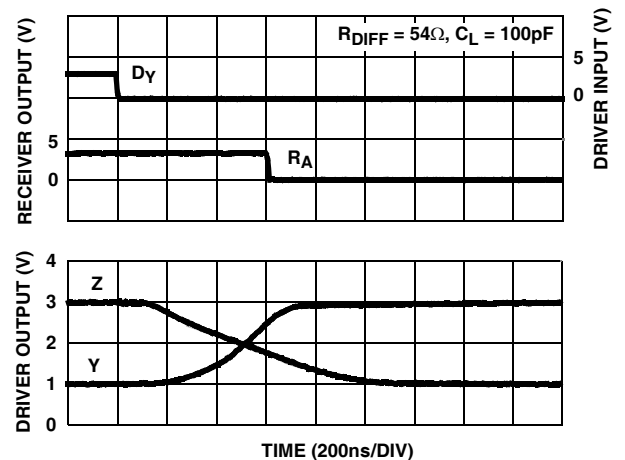

FIGURE 30. RS-485, DRIVER AND RECEIVER WAVEFORMS, HIGH TO LOW (MEDIUM DATA RATE)

**Typical Performance Curves**  $V_{CC} = V_L = 3.3V$ ,  $T_A = +25^\circ C$ ; Unless Otherwise Specified (Continued)

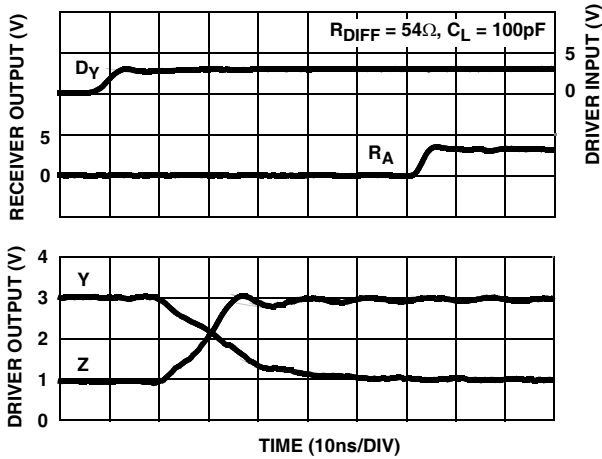

FIGURE 31. RS-485, DRIVER AND RECEIVER WAVEFORMS, LOW TO HIGH (FAST DATA RATE)

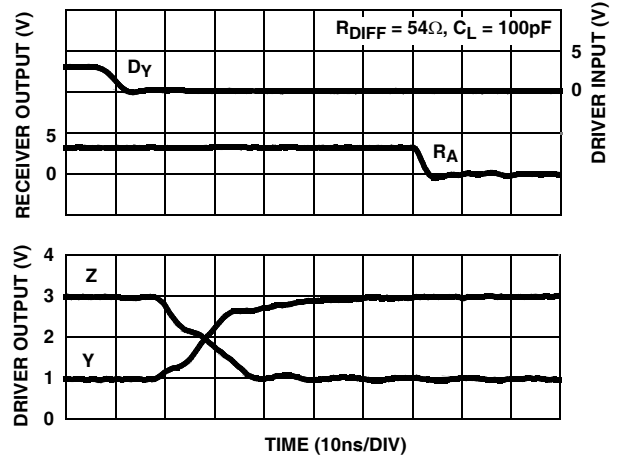

FIGURE 32. RS-485, DRIVER AND RECEIVER WAVEFORMS, HIGH TO LOW (FAST DATA RATE)

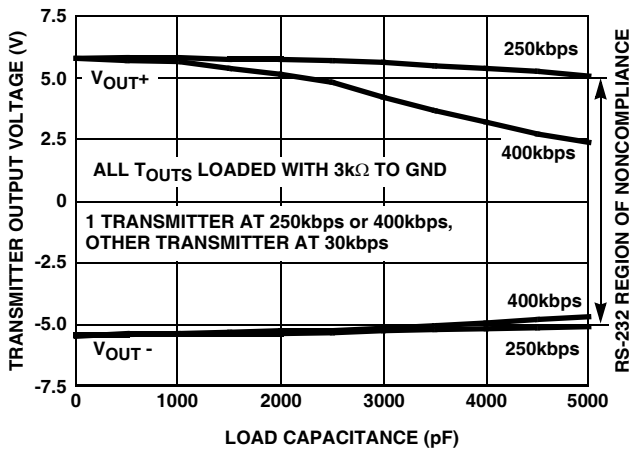

FIGURE 33. RS-232, TRANSMITTER OUTPUT VOLTAGE vs LOAD CAPACITANCE

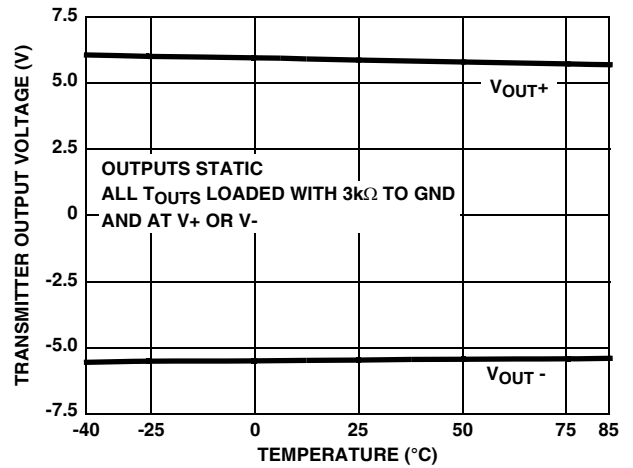

FIGURE 34. RS-232, TRANSMITTER OUTPUT VOLTAGE vs TEMPERATURE

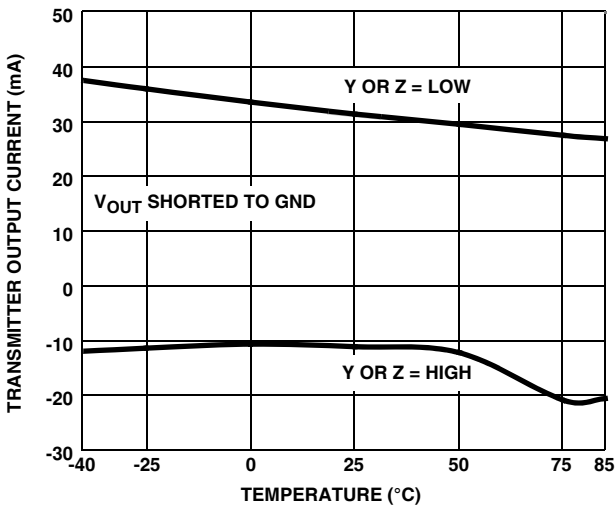

FIGURE 35. RS-232, TRANSMITTER SHORT CIRCUIT CURRENT vs TEMPERATURE

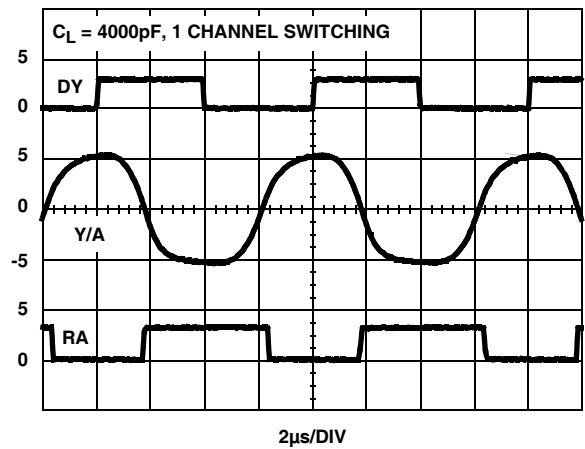

FIGURE 36. RS-232, TRANSMITTER AND RECEIVER WAVEFORMS AT 250kbps



**Typical Performance Curves**  $V_{CC} = V_L = 3.3V$ ,  $T_A = +25^\circ C$ ; Unless Otherwise Specified (Continued)

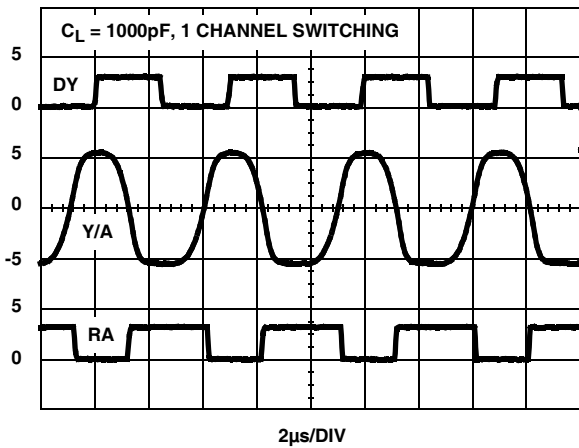

FIGURE 37. RS-232, TRANSMITTER AND RECEIVER WAVEFORMS AT 400kbps

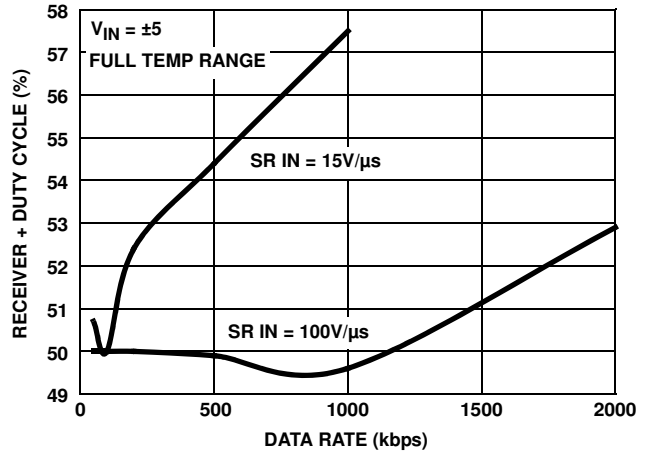

FIGURE 38. RS-232, RECEIVER OUTPUT + DUTY CYCLE vs DATA RATE

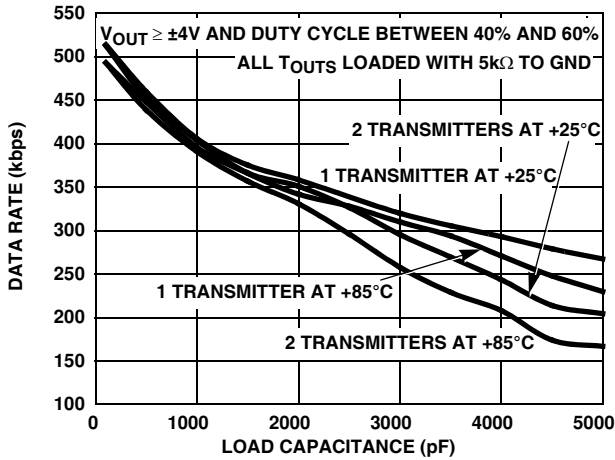

FIGURE 39. RS-232, TRANSMITTER MAXIMUM DATA RATE vs LOAD CAPACITANCE

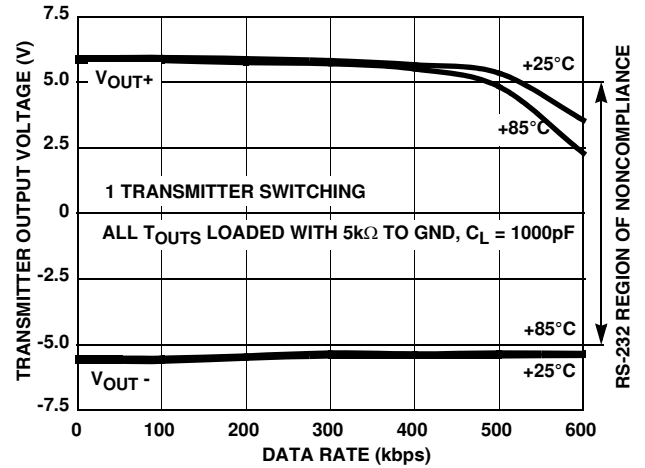

FIGURE 40. RS-232, TRANSMITTER OUTPUT VOLTAGE vs DATA RATE

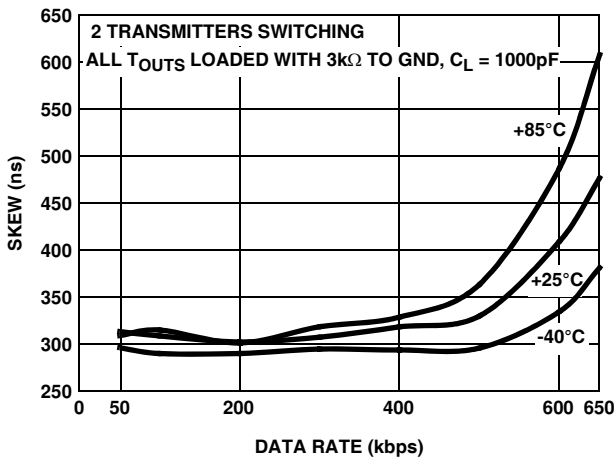

FIGURE 41. RS-232, TRANSMITTER SKEW vs DATA RATE

**Die Characteristics**

SUBSTRATE AND QFN PAD POTENTIAL (POWERED UP):

GND

TRANSISTOR COUNT:

2490

PROCESS:

BiCMOS

# Package Outline Drawing

## L40.6x6

40 LEAD QUAD FLAT NO-LEAD PLASTIC PACKAGE

Rev 3, 10/06

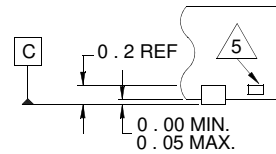
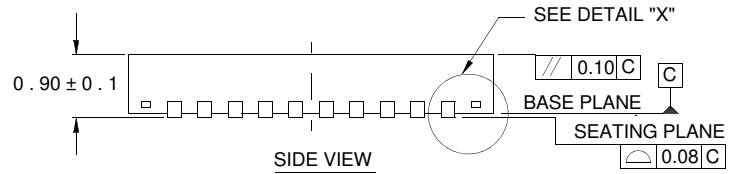
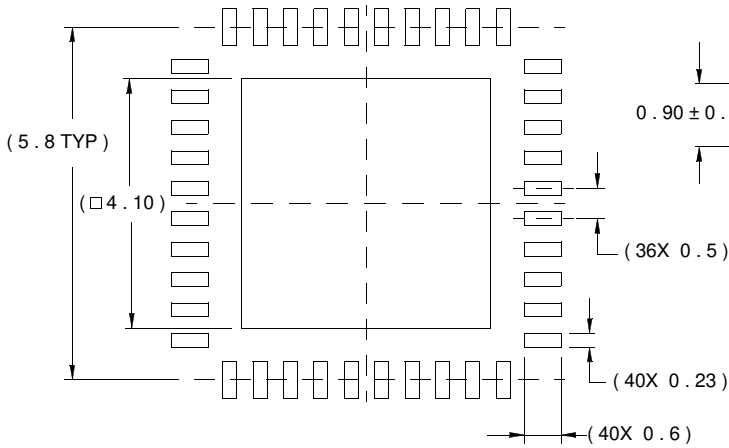
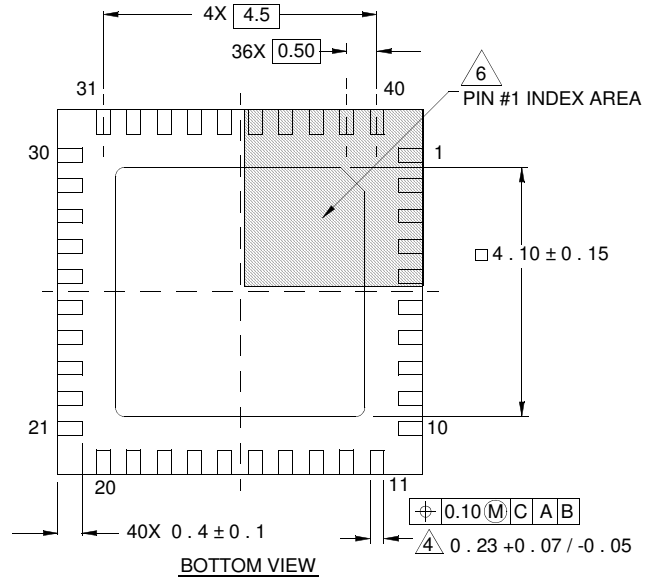
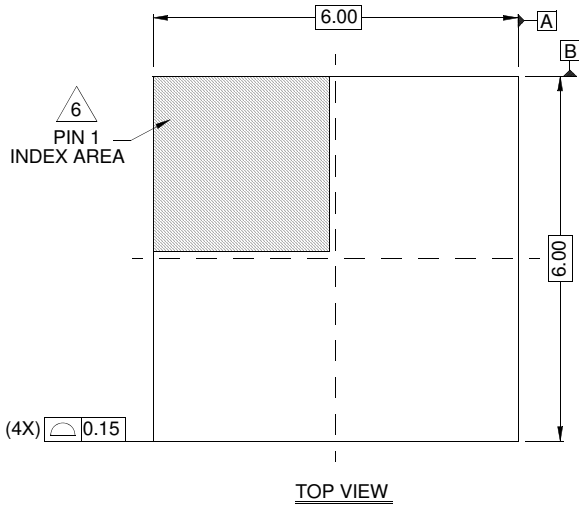

NOTES:

1. Dimensions are in millimeters.  
Dimensions in ( ) for Reference Only.
2. Dimensioning and tolerancing conform to AMSE Y14.5m-1994.
3. Unless otherwise specified, tolerance : Decimal ± 0.05
4. Dimension b applies to the metallized terminal and is measured between 0.15mm and 0.30mm from the terminal tip.
5. Tiebar shown (if present) is a non-functional feature.
6. The configuration of the pin #1 identifier is optional, but must be located within the zone indicated. The pin #1 identifier may be either a mold or mark feature.

**Shrink Small Outline Plastic Packages (SSOP)**

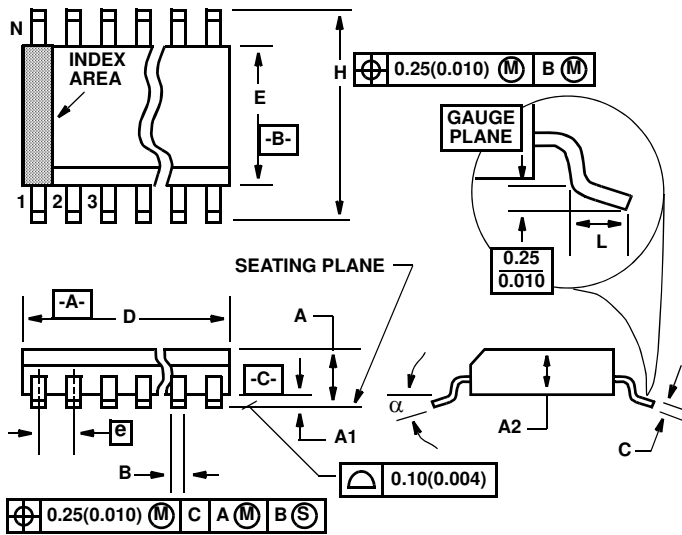

**M20.209 (JEDEC MO-150-AE ISSUE B)  
20 LEAD SHRINK SMALL OUTLINE PLASTIC PACKAGE**

SYMBOL	INCHES		MILLIMETERS		NOTES
	MIN	MAX	MIN	MAX	
A	0.068	0.078	1.73	1.99	
A1	0.002	0.008	0.05	0.21	
A2	0.066	0.070	1.68	1.78	
B	0.010	0.015	0.25	0.38	9
C	0.004	0.008	0.09	0.20	
D	0.278	0.289	7.07	7.33	3
E	0.205	0.212	5.20	5.38	4
e	0.026 BSC		0.65 BSC		
H	0.301	0.311	7.65	7.90	
L	0.025	0.037	0.63	0.95	6
N	20		20		7
$\alpha$	0 deg.	8 deg.	0 deg.	8 deg.	

**NOTES:**

1. Symbols are defined in the "MO Series Symbol List" in Section 2.2 of Publication Number 95.
2. Dimensioning and tolerancing per ANSI Y14.5M-1982.
3. Dimension "D" does not include mold flash, protrusions or gate burrs. Mold flash, protrusion and gate burrs shall not exceed 0.20mm (0.0078 inch) per side.
4. Dimension "E" does not include interlead flash or protrusions. Interlead flash and protrusions shall not exceed 0.20mm (0.0078 inch) per side.
5. The chamfer on the body is optional. If it is not present, a visual index feature must be located within the crosshatched area.
6. "L" is the length of terminal for soldering to a substrate.
7. "N" is the number of terminal positions.
8. Terminal numbers are shown for reference only.
9. Dimension "B" does not include dambar protrusion. Allowable dambar protrusion shall be 0.13mm (0.005 inch) total in excess of "B" dimension at maximum material condition.
10. Controlling dimension: MILLIMETER. Converted inch dimensions are not necessarily exact.

Rev. 3 11/02

All Intersil U.S. products are manufactured, assembled and tested utilizing ISO9000 quality systems. Intersil Corporation's quality certifications can be viewed at [www.intersil.com/design/quality](http://www.intersil.com/design/quality)

*Intersil products are sold by description only. Intersil Corporation reserves the right to make changes in circuit design, software and/or specifications at any time without notice. Accordingly, the reader is cautioned to verify that data sheets are current before placing orders. Information furnished by Intersil is believed to be accurate and reliable. However, no responsibility is assumed by Intersil or its subsidiaries for its use; nor for any infringements of patents or other rights of third parties which may result from its use. No license is granted by implication or otherwise under any patent or patent rights of Intersil or its subsidiaries.*

For information regarding Intersil Corporation and its products, see [www.intersil.com](http://www.intersil.com)