



Chipsmall Limited consists of a professional team with an average of over 10 year of expertise in the distribution of electronic components. Based in Hongkong, we have already established firm and mutual-benefit business relationships with customers from,Europe,America and south Asia,supplying obsolete and hard-to-find components to meet their specific needs.

With the principle of "Quality Parts,Customers Priority,Honest Operation,and Considerate Service",our business mainly focus on the distribution of electronic components. Line cards we deal with include Microchip,ALPS,ROHM,Xilinx,Pulse,ON,Everlight and Freescale. Main products comprise IC,Modules,Potentiometer,IC Socket,Relay,Connector.Our parts cover such applications as commercial,industrial, and automotives areas.

We are looking forward to setting up business relationship with you and hope to provide you with the best service and solution. Let us make a better world for our industry!



Contact us

Tel: +86-755-8981 8866 Fax: +86-755-8427 6832

Email & Skype: info@chipsmall.com Web: www.chipsmall.com

Address: A1208, Overseas Decoration Building, #122 Zhenhua RD., Futian, Shenzhen, China



To request the full datasheet, please visit www.intersil.com/products/ISL58303

800mA Triple Output Laser Diode Driver

ISL58303

The **ISL58303** is a high-speed triple output laser diode driver designed to support color field sequential laser light source Pico projection modules. Outputs can be ganged together to achieve peak total current greater than 3.6A. Output channels are designed with independent programmable bias and threshold adjustment to support a wide range of laser diode manufacturers. The ISL58303 offers exceptional power efficiency and a high degree of system integration allowing a compact and cost effective system design.

To assist with reduction of laser speckle, this laser diode driver has a high frequency modulation input to modulate laser pulses. This can be used to achieve outputs pulses of less than 1ns.

Interface to the system is accomplished via a high-speed serial bus that is made up of SEN, SCLK and SDIO. Initialization of internal registers after power-on reset, operational setup and laser intensity data for each output channel are communicated through this bus.

For laser operational safety, a hardware enable signal (CE) is ANDed with an internal register bit. Both have to be asserted to enable the device. This prevents an accidental fault causing an unwanted laser output.

Features

- Complete triple programmable laser diode driver
- 800mA maximum output current per channel
- 1200mA peak output current per channel
- Ganging of multiple channels as well as multiple chips can be done to meet the highest current demands
- ISL58303 has all N-MOS output channels (I_{OUT1} , I_{OUT2} and I_{OUT3}) for common anode laser diode configurations
- Independent output channel enable
- Programmable threshold DACs and color DACs for each channel
- Supports High Frequency Modulation (HFM) that switches all 3 outputs in unison producing pulse widths of less than 1ns.
- Fast SPI serial interface
- Space saving package: 24 Ld 4mmx4mm TQFN

Applications

- RGB color field sequential laser projection system
- Time of flight measurement systems
- High speed/high current laser diode systems

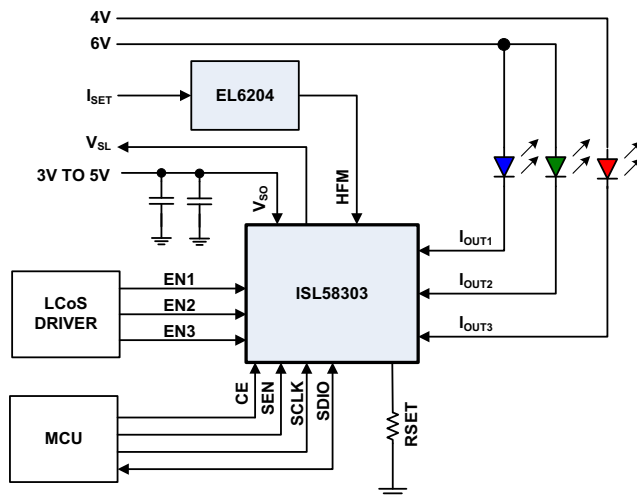

FIGURE 1. ISL58303 TYPICAL APPLICATION LCOS

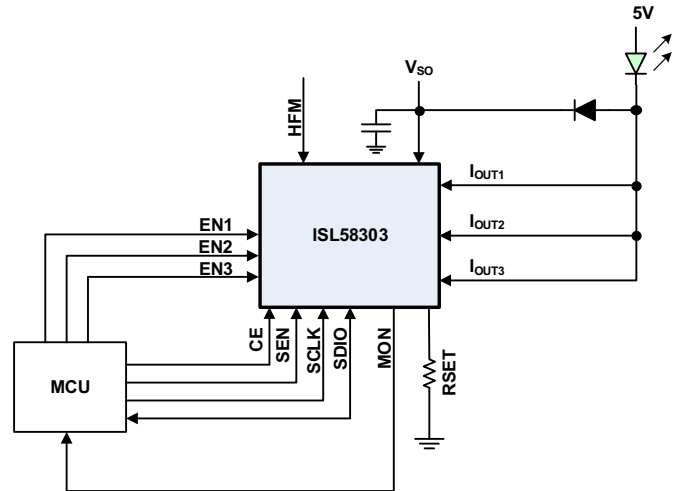

FIGURE 2. ISL58303 TYPICAL APPLICATION HIGH CURRENT

For additional products, see www.intersil.com/en/products.html

Intersil products are manufactured, assembled and tested utilizing ISO9001 quality systems as noted in the quality certifications found at www.intersil.com/en/support/qualandreliability.html

Intersil products are sold by description only. Intersil Corporation reserves the right to make changes in circuit design, software and/or specifications at any time without notice. Accordingly, the reader is cautioned to verify that data sheets are current before placing orders. Information furnished by Intersil is believed to be accurate and reliable. However, no responsibility is assumed by Intersil or its subsidiaries for its use; nor for any infringements of patents or other rights of third parties which may result from its use. No license is granted by implication or otherwise under any patent or patent rights of Intersil or its subsidiaries.

For information regarding Intersil Corporation and its products, see www.intersil.com