



Chipsmall Limited consists of a professional team with an average of over 10 year of expertise in the distribution of electronic components. Based in Hongkong, we have already established firm and mutual-benefit business relationships with customers from,Europe,America and south Asia,supplying obsolete and hard-to-find components to meet their specific needs.

With the principle of “Quality Parts,Customers Priority,Honest Operation,and Considerate Service”,our business mainly focus on the distribution of electronic components. Line cards we deal with include Microchip,ALPS,ROHM,Xilinx,Pulse,ON,Everlight and Freescale. Main products comprise IC,Modules,Potentiometer,IC Socket,Relay,Connector.Our parts cover such applications as commercial,industrial, and automotives areas.

We are looking forward to setting up business relationship with you and hope to provide you with the best service and solution. Let us make a better world for our industry!



## Contact us

Tel: +86-755-8981 8866 Fax: +86-755-8427 6832

Email & Skype: info@chipsmall.com Web: www.chipsmall.com

Address: A1208, Overseas Decoration Building, #122 Zhenhua RD., Futian, Shenzhen, China



# High Speed Triple Laser Diode Drivers

## ISL58315

The ISL58315 is a high-speed, triple-output laser diode driver (LDD) for laser scanning projector systems, which require three channels modulated at high speed with independent current control.

Each output channel provides laser-independent current control for threshold and color DACs. Separate scale DACs allow independent scaling of both threshold and color DAC output values. This allows control of projector brightness and can be used to simplify automatic power calibration (APC) for laser-based systems.

Pixel data information is transferred through the LDD's high-speed 10-bit or 15-bit parallel video interface. Three parallel interface modes provide flexibility and allow users a trade-off among speed, power and bus width. Pixel data employs a double data rate scheme, allowing video data to be transferred using both clock edges.

### Applications

- Laser-based Pico Projectors
- RGB Scanning and Field-based laser projection systems
- Generic laser-based applications requiring multiple, independently controlled lasers

### Related Literature

- See application block diagram for Pico Projector (MEMS) at: <http://www.intersil.com/applications/PicoProjector%28MEMS%29.asp>

### Features

- High-speed, triple-output laser diode driver supporting up to 720-pixel HD resolution
- Up to 1A of peak current output
- Fast output switching speeds with pulse rise/fall times of 1ns to 2ns for crisp pixels
- Intersil patented laser voltage sampler function provides dynamic power management capability to dramatically minimize system power
- Intersil patented SmartLinearizer™ DAC feature provides a linear transfer function (input video code to green laser output), eliminating the need for DSP controller processing algorithms required for non-linear green lasers
- Flexible 10-bit or Intersil patented 15-bit RGB pixel input formats supported to reduce speed and power. 300MHz maximum data Input rate supported for 10-bit RGB mode
- Blanking time power reduction reduces LDD current consumption to 3mA typical
- Programmable return-to-zero (RTZ) function provides maximum flexibility
- Integrated heater function for SHG green lasers reduces external components
- Single 3.3V supply and 1.8V video interface compatible for low power

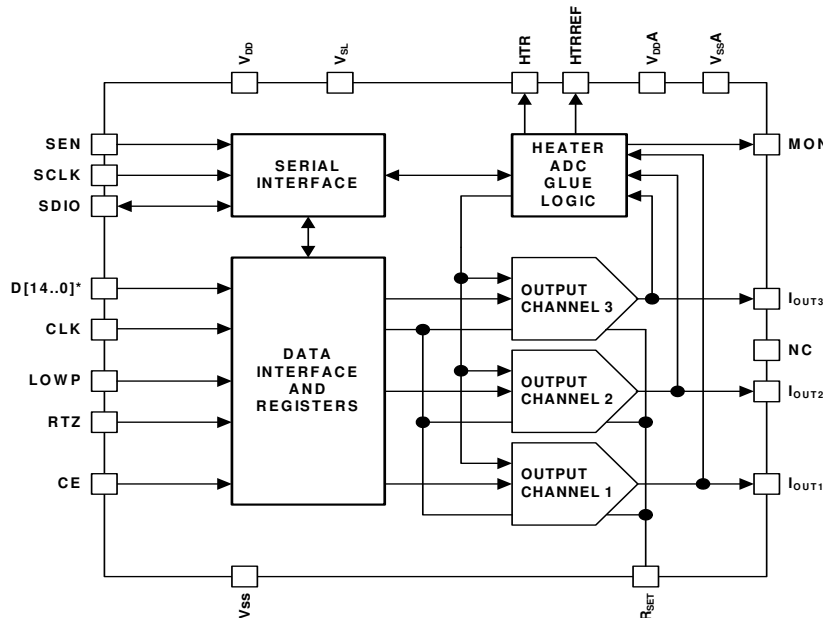

NOTE:  
\* THE FOLLOWING DATA LINES HAVE ALTERNATIVE USE, DEPENDING ON REGISTER SETTING: D2 = EN3, D4 = EN2, D6 = EN1, AND D10 = SYNC

FIGURE 1. BLOCK DIAGRAM

**CONFIDENTIAL**

For additional products, see [www.intersil.com/product\\_tree](http://www.intersil.com/product_tree)

---

Intersil products are manufactured, assembled and tested utilizing ISO9000 quality systems as noted in the quality certifications found at [www.intersil.com/design/quality](http://www.intersil.com/design/quality)

---

*Intersil products are sold by description only. Intersil Corporation reserves the right to make changes in circuit design, software and/or specifications at any time without notice. Accordingly, the reader is cautioned to verify that data sheets are current before placing orders. Information furnished by Intersil is believed to be accurate and reliable. However, no responsibility is assumed by Intersil or its subsidiaries for its use; nor for any infringements of patents or other rights of third parties which may result from its use. No license is granted by implication or otherwise under any patent or patent rights of Intersil or its subsidiaries.*

---

For information regarding Intersil Corporation and its products, see [www.intersil.com](http://www.intersil.com)