



Chipsmall Limited consists of a professional team with an average of over 10 year of expertise in the distribution of electronic components. Based in Hongkong, we have already established firm and mutual-benefit business relationships with customers from,Europe,America and south Asia,supplying obsolete and hard-to-find components to meet their specific needs.

With the principle of “Quality Parts,Customers Priority,Honest Operation,and Considerate Service”,our business mainly focus on the distribution of electronic components. Line cards we deal with include Microchip,ALPS,ROHM,Xilinx,Pulse,ON,Everlight and Freescale. Main products comprise IC,Modules,Potentiometer,IC Socket,Relay,Connector.Our parts cover such applications as commercial,industrial, and automotives areas.

We are looking forward to setting up business relationship with you and hope to provide you with the best service and solution. Let us make a better world for our industry!



Contact us

Tel: +86-755-8981 8866 Fax: +86-755-8427 6832

Email & Skype: info@chipsmall.com Web: www.chipsmall.com

Address: A1208, Overseas Decoration Building, #122 Zhenhua RD., Futian, Shenzhen, China



3V Wide Optical Spectrum Laser Power Monitor IC

ISL58334

The ISL58334 photo sensor IC has a wide optical spectral sensitivity from 400nm to 1000nm. It is good for multiple light sources application, such as laser based projectors. ISL58334 has two banks of three sets of gain registers. For a Pico-Projector application, the two banks of gain resistors can be used to monitor bias level and peak level of each wavelength. Bank switching is done by applying a TTL compatible logic signal to HL pin. The three sets of gain registers can be used to adjust optical-to-electrical conversion gain for each RED, GREEN, and BLUE laser or any wavelength in a spectral range for application. The ISL58334 is a single die device that has a photo detector of 0.7mm diameter in the center of the die. Photo current signal is amplified through TIA, fine gain amplifier, and output drivers to convert from current to voltage. The output of the ISL58334 can be configured to be either differential or single-ended. Gain changing according to each wavelength is done through 3-wire interface. Registers can be updated in real time while the device is in operation.

The ISL58334 operates from a single +3.3V supply. It is available in a space-saving 9 ball glass top BGA package.

Related Literature

- See [TB478](#) "PCB Assembly Guidelines for Shell-Op 3D Package"

Features

- High Sensitivity from 400nm to 1000nm with Patented Technology for Improved Blue Photo Response
- Differential Voltage Output or Single-Ended Output
- Internal Output Reference or External Output Reference
- Single +3.3V Power Supply
- Serial Interface for Gain Calibration
- Fast Settling Time < 20ns
- Wide Signal Bandwidth > 80MHz
- Wide Signal Gain Dynamic Range > 20dB
- Low Power Consumption
- Low Output Offset < 50mV
- Small 9-Ball Optical Chip Scale Package (OCSP) (2.2mmx2.2mm)
- SPI 3-wire serial interface

Applications

- Optical Power Monitoring
- Laser Based Pico-Projectors or Projection TV
- Laser Auto Power Control for laser based application

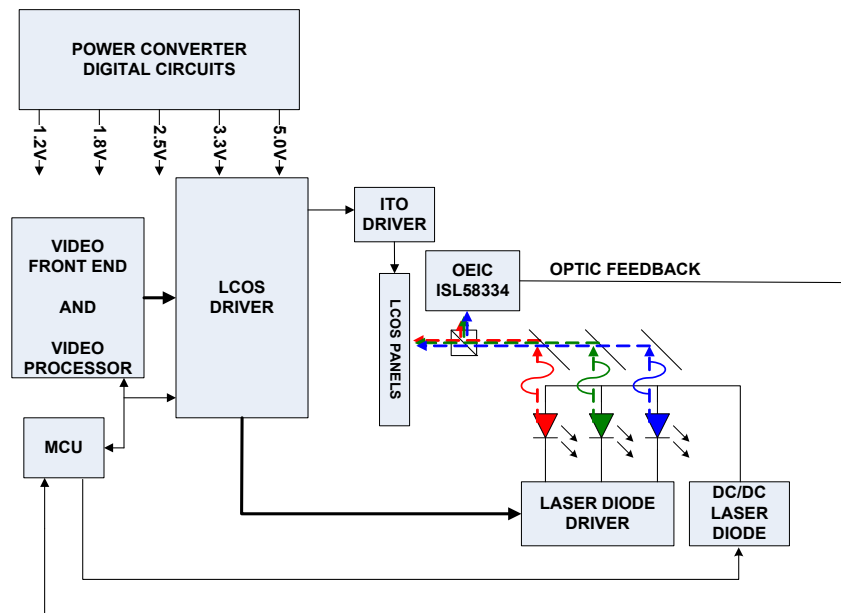

FIGURE 1. APPLICATION BLOCK DIAGRAM

For additional products, see www.intersil.com/product_tree

Intersil products are manufactured, assembled and tested utilizing ISO9001 quality systems as noted in the quality certifications found at www.intersil.com/design/quality

Intersil products are sold by description only. Intersil Corporation reserves the right to make changes in circuit design, software and/or specifications at any time without notice. Accordingly, the reader is cautioned to verify that data sheets are current before placing orders. Information furnished by Intersil is believed to be accurate and reliable. However, no responsibility is assumed by Intersil or its subsidiaries for its use; nor for any infringements of patents or other rights of third parties which may result from its use. No license is granted by implication or otherwise under any patent or patent rights of Intersil or its subsidiaries.

For information regarding Intersil Corporation and its products, see www.intersil.com